

## **Built-in OVP White LED Step-up Converter**

---

### Features

- Integrated open-circuit protection
- Over voltage protection
- Up to 84% efficiency at  $V_{IN}=3V$ , 3LEDs,  $I_{LED}=20mA$
- 1.2MHz fixed switching frequency
- Low standby current:  $0.1\mu A$  (typ.) ( $V_{SHDN}=0V$ )
- Matches LED current
- Small value inductor and capacitors
- Small outline SOT23-6 package

### Applications

- Cellular phones
- PDAs
- DSCs
- Handheld devices
- White LED display backlighting

### General Description

The HT7937 is high efficiency boost converter with a constant current output to provide back light functions in handheld devices. Applications with series connected LEDs ensure constant and identical LED currents resulting in uniform brightness. A continuous LED output current is setup using the FB pin regulated voltage across an external sense resistor,  $R_{FB}$  connected between the FB pin and ground. The integrated open load protection circuitry prevents damage resulting from an

open circuit condition. The low 95mV feedback voltage minimises power losses in the current setting resistor which improves efficiency. The HT7937 has a high switching frequency of up to 1.2MHz which permits the use of lower value extremely small outline inductor and filter capacitor.

The HT7937 is supplied in a space-saving, 6-lead SOT23-6 package type.

### Selection Table

Part No.	Package	Marking
HT7937	SOT23-6	7937# 7937+

Note: Both lead free and green compound devices are available.

"#" stands for Lead-free devices.

"+" stands for green compound devices, which are Lead-free and Halogen-free.

**Block Diagram**

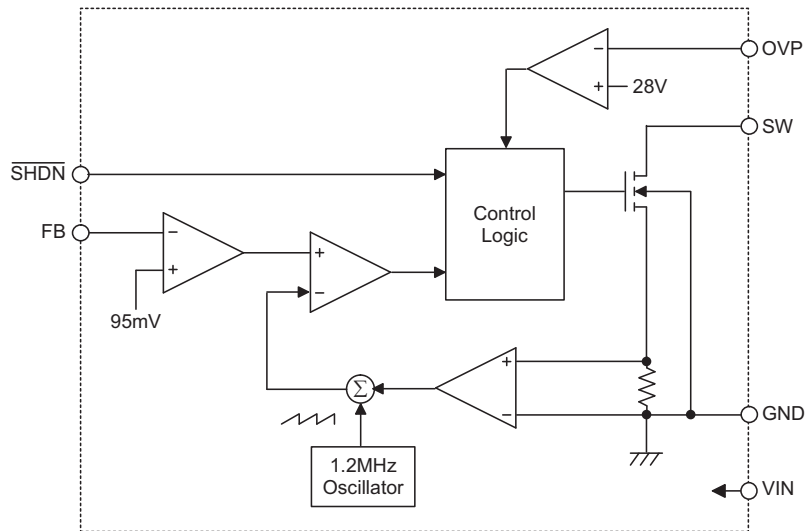

**Pin Assignment**

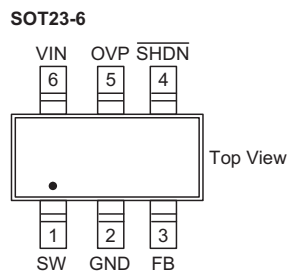

**Pin Description**

Pin No.	Pin Name	Description
1	SW	Switching pin
2	GND	Ground pin
3	FB	Output voltage sense node. Connect the cathode of the LED to this pin. A resistor from this pin to ground sets the LED current. Internally compares to 95mV (Typ.).
4	$\overline{\text{SHDN}}$	Shutdown device pin. Connect to 1.5V or higher to enable device (ON), 0.3V or lower to disable device (OFF).
5	OVP	For over voltage protection connect to the output.
6	VIN	Input voltage pin. 2.5V to 5.5V for internal circuitry.

**Absolute Maximum Ratings**

Input Voltage.....	6V	SW Voltage.....	36V
FB Voltage.....	6V	$\overline{\text{SHDN}}$ .....	6V
OVP Voltage.....	36V	Operating Temperature Range.....	-40°C to 85°C
Maximum Junction Temperature.....	125°C		

Note: These are stress ratings only. Stresses exceeding the range specified under "Absolute Maximum Ratings" may cause substantial damage to the device. Functional operation of this device at other conditions beyond those listed in the specification is not implied and prolonged exposure to extreme conditions may affect device reliability.

**Electrical Characteristics**
 $V_{\overline{\text{SHDN}}}=3\text{V}; V_{\text{IN}}=3\text{V}; T_a=25^\circ\text{C}$  (Unless otherwise specified)(Note)

Symbol	Parameter	Test Conditions	Min.	Typ.	Max.	Unit
$V_{\text{IN}}$	Input Voltage	—	2.5	3	5.5	V
$I_{\text{IN}}$	Supply Current	Switching	—	1.0	1.25	mA
		Non-switching	—	50	100	$\mu\text{A}$
		$V_{\overline{\text{SHDN}}}=0\text{V}$	—	0.1	1	$\mu\text{A}$
$V_{\text{FB}}$	Feedback Voltage	3 LEDs	85	95	105	mV
$f_{\text{OSC}}$	Switching Frequency	Measurement at SW pin	0.8	1.2	1.6	MHz
$D_{\text{C}}$	Maximum Duty Cycle		85	90	—	%
$R_{\text{DS(ON)}}$	SW On Resistance	—	—	1.4	5	$\Omega$
$I_{\text{SW(OFF)}}$	Switch Leakage Current	—	—	0.1	1	$\mu\text{A}$
$V_{\text{IH}}$	$\overline{\text{SHDN}}$ Voltage High	—	1.5	—	—	V
$V_{\text{IL}}$	$\overline{\text{SHDN}}$ Voltage Low	—	—	—	0.3	V
$V_{\text{OVP}}$	OVP Threshold	No load	23	28	33	V

Note: Specifications are production tested at  $T_a=25$  degree. Specifications over -40 to 85 degree operating temperature range are assured by design, characterization.

**Functional Description**

• Shutdown

The shutdown pin, SHDN, must not be allowed to float. When the SHDN pin voltage is taken below 0.3V, the internal MOSFET, voltage reference, error amplifier, comparators and biasing circuitry will all be switched off reducing the quiescent supply current to less than 1µA. If the SHDN pin has a value greater than 1.5V, then the device will be fully enabled and operational. This pin also can be used as a PWM signal from 100Hz to 1kHz to allow brightness control.

• Over voltage protection – OVP

With an open circuit output, such as when no LEDs are connected, the FB pin will be pulled down to ground via the sense resistor R<sub>FB</sub>. As the device will now react by trying to increase the output voltage by generating a maximum duty cycle signal, this may cause the SW pin to exceed its maximum rated voltage, which may damage the internal N-MOS switching transistor.

The OVP function is designed to prevent damage to the internal NMOS switching transistor. When the output voltage rises above the OVP threshold voltage, typically 28V, the converter will clamp the output voltage to this level. When the output voltage returns to a value below the OVP threshold, it will automatically resume normal switching operation.

• Dimming control

There are three methods to control the LEDs brightness as listed below:

♦ A PWM signal on the SHDN pin

A PWM signal is applied to the SHDN pin as shown in Figure 1.

The magnitude of the PWM signal should be higher than the enable voltage of the SHDN pin, the LEDs operate with either zero or full current. The average LED current is proportional to the duty cycle of the applied PWM signal with a duty cycle increase resulting in higher LEDs brightness. Typical PWM frequencies should be between 100Hz and 1kHz.

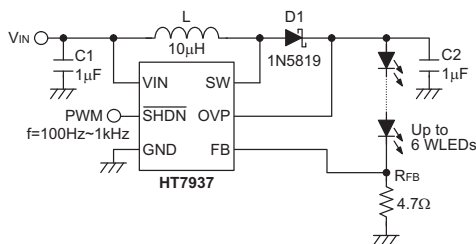

Figure 1. Dimming Control with PWM Signal

♦ A DC signal on the FB pin

This method of dimming control uses a DC voltage circuit as shown in Figure 2.

The LED brightness is directly proportional to the LED current which is given by the following equation:

$$I_{LED} = \frac{V_{FB} \times (R1 + R2) - V_{DC} \times R1}{R2 \times R_{FB}}$$

Where

V<sub>FB</sub> = Feedback voltage is 95mV

V<sub>DC</sub> = DC voltage

R1 and R2 >> R<sub>FB</sub>

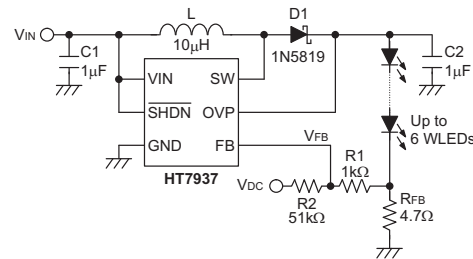

Figure 2. Dimming Control Using a DC Voltage

♦ A filtered PWM signal on the FB pin

For frequencies greater than 1kHz, dimming can be implemented by using the circuit shown in Figure 3.

The PWM control circuitry is connected to the FB pin. Reducing the duty cycle on the PWM signal results in increased LEDs brightness levels. The LED brightness is directly proportional to the LED current which is given by the following equation:

$$I_{LED} = \frac{V_{FB} \times (R1 + R2) - V_{PWM} \times D \times R1}{R2 \times R_{FB}}$$

Where

V<sub>FB</sub> = Feedback voltage is 95mV

V<sub>PWM</sub> = PWM high level voltage

D = PWM duty cycle

R1 and R2 >> R<sub>FB</sub>

$$PWM \text{ frequency} \gg \frac{1}{2\pi R3 C3}$$

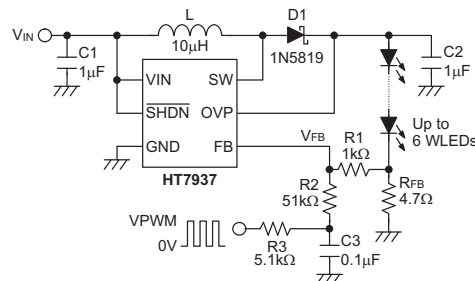

Figure 3. Dimming Control Using a Filter PWM Signal

**Component Selection**

• **Setting the LED Current**

The step-up converter regulates the LED current by regulating the voltage across the current sense resistor,  $R_{FB}$ . To ensure the generation of accurate LED currents, it is recommended that a precision resistor is used for  $R_{FB}$ . The voltage across the sense resistor is regulated to the internal reference voltage of 95mV. The LED current is calculated using the following equation:

$$I_{LED} = \frac{V_{FB}}{R_{FB}}$$

Where

$V_{FB}$  = Feedback voltage is 95mV

• **Inductor Selection**

The selected inductor must have a saturation current greater than the maximum peak current of the step-up converter. A recommended value of inductor for 3 to 6 white LED applications is 4.7μH to 22μH. For good efficiency the inductor should have low core loss and low DCR (DC Resistance).

The peak inductor current is calculated using the following equation:

$$I_{L(PEAK)} = \frac{V_o \times I_o}{V_i \times \eta} + \frac{V_i \times (V_o - V_i)}{2 \times V_o \times L \times F_s}$$

Where

$V_o$  = Output Voltage

$V_i$  = Input Voltage

$I_o$  = Output Current

$\eta$  = Efficiency

$L$  = Inductance

$F_s$  = Switching Frequency is 1.2MHz

• **Diode Selection**

The diode must have a rating greater than the output voltage and output current. In switching applications both forward voltage drop and diode capacitance are important considerations.

A Schottky diode is used due to its low forward voltage drop and fast switching speeds which improves efficiency. The Schottky diode has average current of  $I_o$ , and a peak current which is the same as the inductor's peak current and a voltage rating at least 1.5 times the output voltage. A recommended Schottky diode type is the 1N5819.

• **Capacitor Selection**

A low ESR (Equivalent Series Resistance) capacitor should be used for the input/output capacitors to minimize ripples. Both X5R and X7R types are suitable due to their wider voltage and temperature ranges. Input and output ceramic capacitors of 1μF are recommended for HT7937 applications.

The output ripple voltage is calculated as the following equation:

$$\Delta V_o = I_{L(PEAK)} \times C_{O(ESR)} + \frac{I_o \times (V_o - V_i)}{V_o \times C_o \times F_s}$$

Where

$I_{L(PEAK)}$  = Peak Inductor Current

$C_{O(ESR)}$  = Output Capacitor's Equivalent Series Resistance

$I_o$  = Output Current

$V_o$  = Output Voltage

$V_i$  = Input Voltage

$C_o$  = Output Capacitance

$F_s$  = Switching Frequency is 1.2MHz

**Layout Considerations**

Circuit board layout is a very important consideration for switching regulators if they are to function properly. Poor circuit layout may result in related noise problems.

In order to minimise EMI and switching noise, please follow the guidelines below:

- All tracks should be as wide as possible.
- The input and output capacitors, C1 and C2, should be placed close to the VIN, VOUT and GND pins.
- The Schottky diode, D1, and inductor, L1, must all be placed close to the SW pin.
- Feedback resistor, R1, must be placed close to the FB and GND pins.
- A full ground plane is always helpful for better EMI performance.

A recommended PCB layout with component locations is shown below.

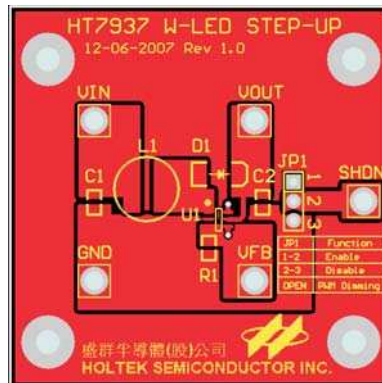

Top Layer

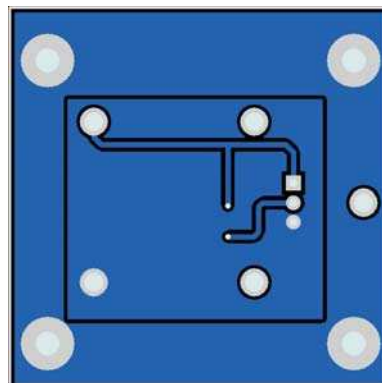

Bottom Layer

**Typical Performance Characteristics**

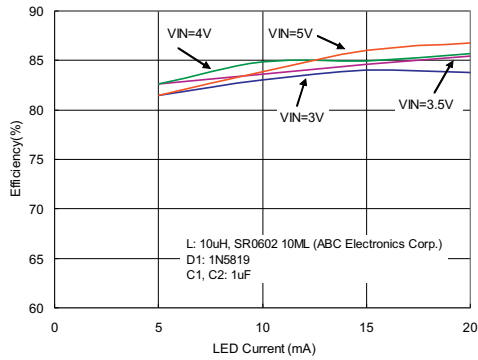

**3 WLEDs Efficiency vs. LED Current**

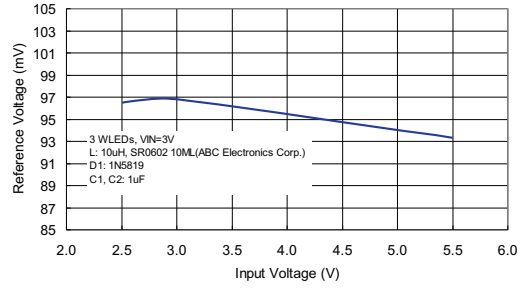

**Input Voltage VS Reference Voltage**



**5 WLEDs Efficiency vs. LED Current**

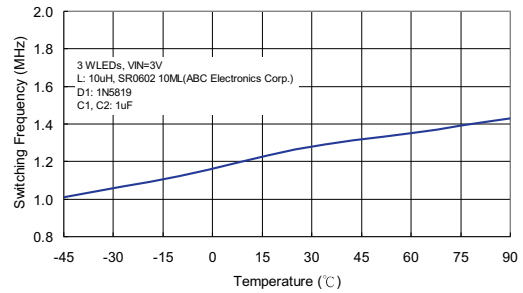

**Temperature VS Switching Frequency**

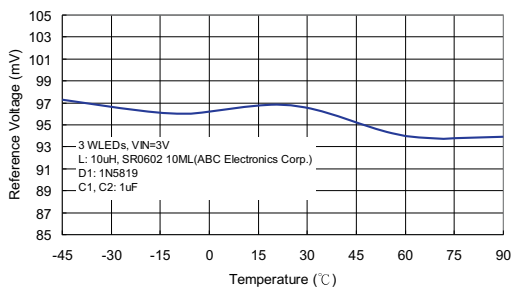

**Temperature VS Reference Voltage**

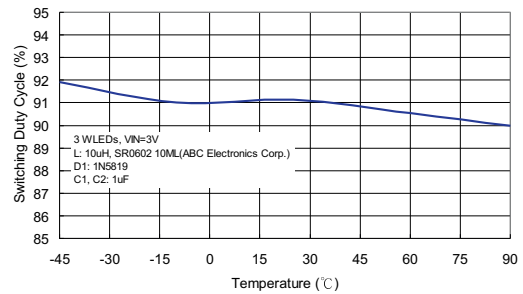

**Temperature VS Switching Duty Cycle**

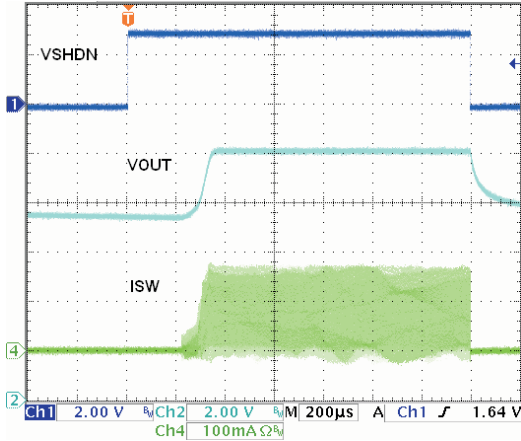

**Start-Up from Shutdown Waveform**

Note: VIN=3.6V, 3 WLEDs, L=10µH, D= 1N5819, Ci=Co=1µF, ILED=20mA

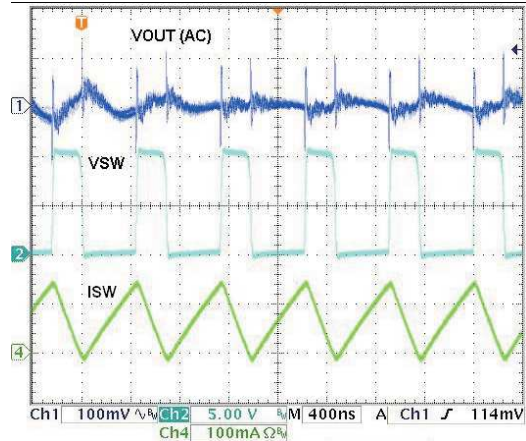

**Operation Waveform**

Note: VIN=3.6V, 3 WLEDs, L=10µH, D=1N5819, Ci=Co=1µF, ILED=20mA

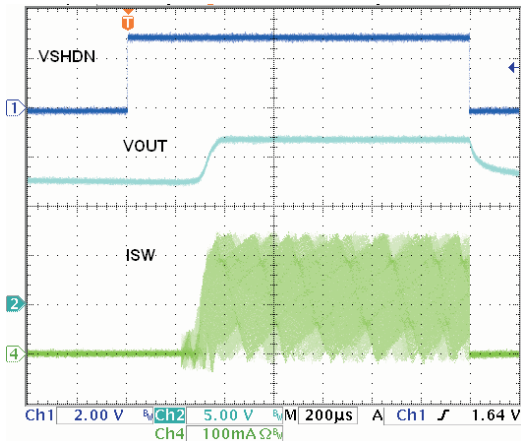

**Start-Up from Shutdown Waveform**

Note: VIN=3.6V, 5 WLEDs, L=10µH, D=1N5819, Ci=Co=1µF, ILED=20mA

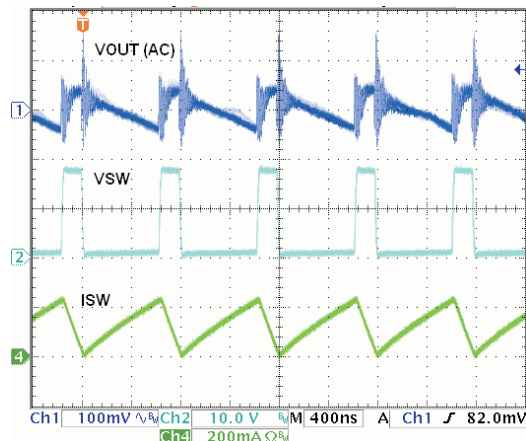

**Operation Waveform**

Note: VIN=3.6V, 5 WLEDs, L=10µH, D=1N5819, Ci=Co=1µF, ILED=20mA

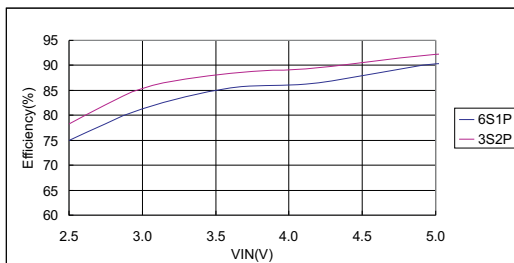

**Efficiency vs. VIN**

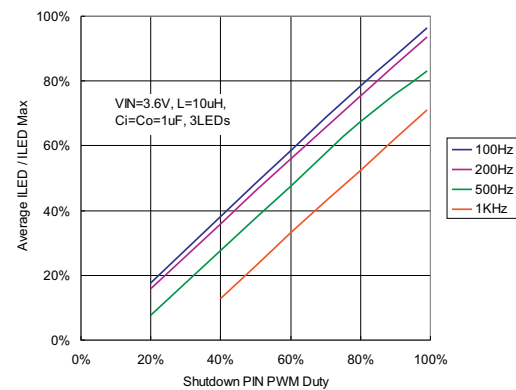

**Dimming Control by Shutdown PIN**

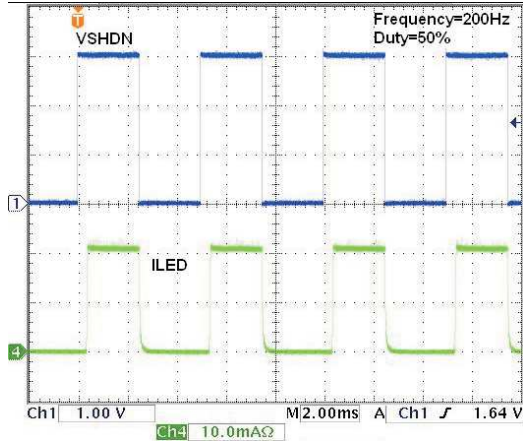

3 WLEDs, VIN=3.6V, f=200Hz, Duty=50%

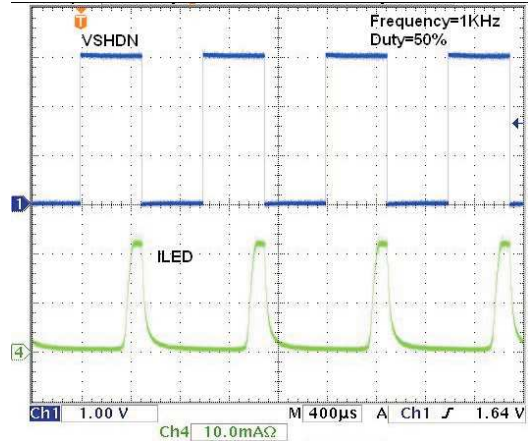

3 WLEDs, VIN=3.6V, f=1kHz, Duty=50%

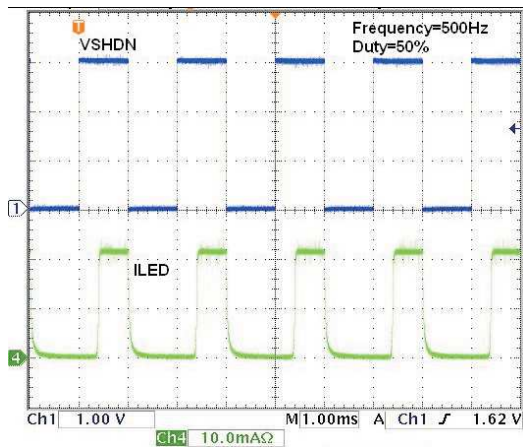

3 WLEDs, VIN=3.6V, f=500Hz, Duty=50%

Application Circuits

6 WLEDs Application Circuit

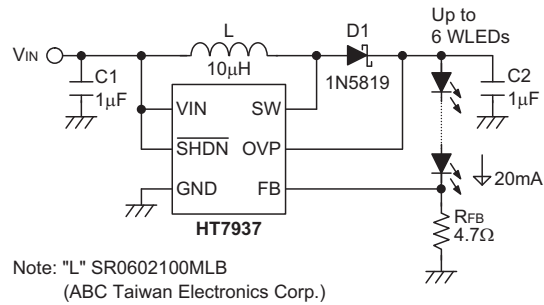

Dimming Control with a PWM Signal

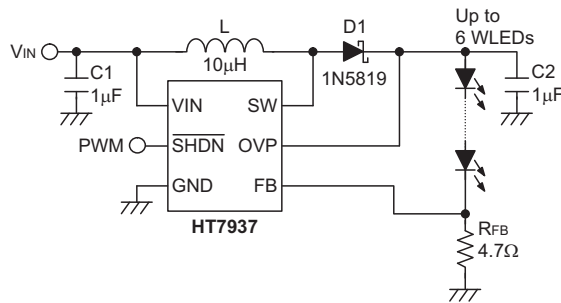

Dimming Control Using a DC Voltage

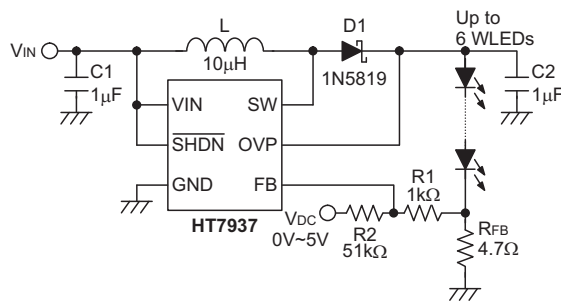

Dimming Control Using a Filter PWM Signal

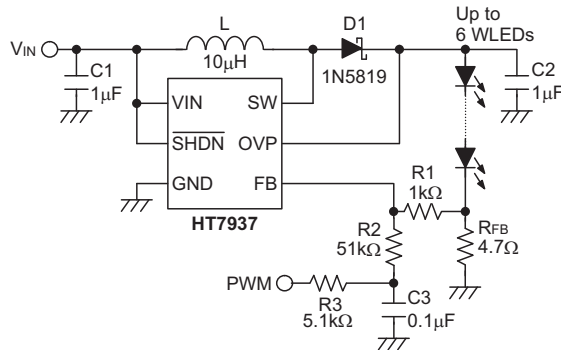

Note: As the above application circuits are unable to show the full drive capabilities and series/parallel drive combinations of this device the following supplemental information is provided.

For the general full voltage range situation:

1. Vin Variable Voltage of 2.6V~5.5V
2. LED forward voltage of 3.5V max.

Maximum LED Drive Capability		
Series	Parallel	Total
3	2	6
4	2	8
5	1	5
6	1	6

It is also important to note that for an input voltage supply which can be maintained at 5.0V or higher, the device possesses even higher drive capabilities which can drive a higher number of parallel connected LEDs. The following table depicts the maximum LED numbers possible for this higher input voltage range.

1. Vin Variable Voltage of 5.0V~5.5V
2. LED forward voltage of 3.5V max.

Maximum LED Drive Capability		
Series	Parallel	Total
3	3	9
4	2	8
5	1	5
6	1	6

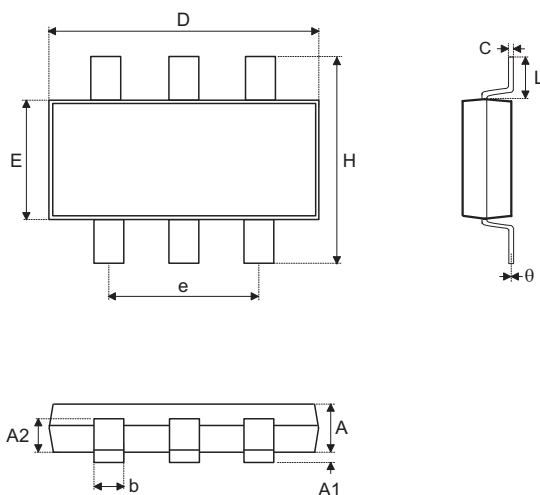
**Package Information**
**6-pin SOT23-6 Outline Dimensions**

Symbol	Dimensions in inch		
	Min.	Nom.	Max.
A	0.039	—	0.051
A1	—	—	0.004
A2	0.028	—	0.035
b	0.014	—	0.020
C	0.004	—	0.010
D	0.106	—	0.122
E	0.055	—	0.071
e	—	0.075	—
H	0.102	—	0.118
L	0.015	—	—
$\theta$	0°	—	9°

Symbol	Dimensions in mm		
	Min.	Nom.	Max.
A	1.00	—	1.30
A1	—	—	0.10
A2	0.70	—	0.90
b	0.35	—	0.50
C	0.10	—	0.25
D	2.70	—	3.10
E	1.40	—	1.80
e	—	1.90	—
H	2.60	—	3.00
L	0.37	—	—
$\theta$	0°	—	9°

**Product Tape and Reel Specifications**

**Reel Dimensions**

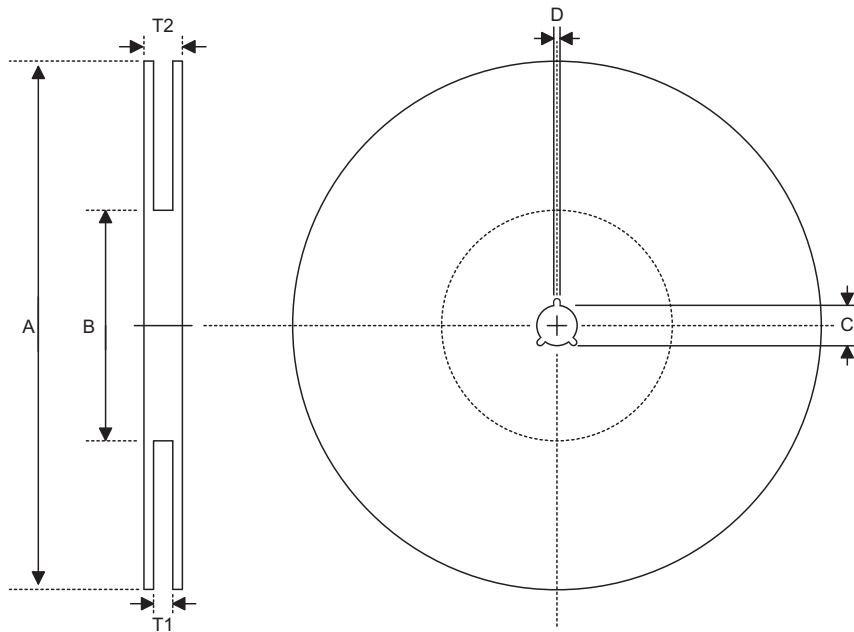

SOT23-6

Symbol	Description	Dimensions in mm
A	Reel Outer Diameter	178.0±1.0
B	Reel Inner Diameter	62.0±1.0
C	Spindle Hole Diameter	13.0±0.2
D	Key Slit Width	2.50±0.25
T1	Space Between Flange	8.4 <sup>+1.5/-0.0</sup>
T2	Reel Thickness	11.4 <sup>+1.5/-0.0</sup>

**Carrier Tape Dimensions**

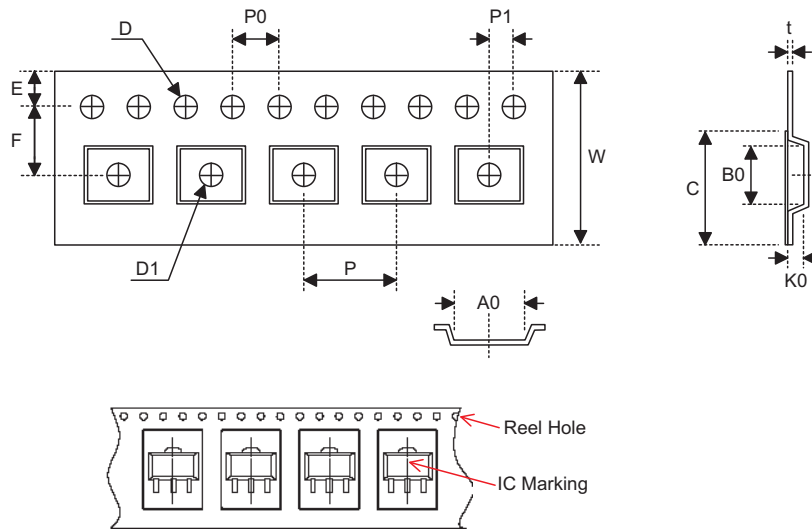

**SOT23-6**

Symbol	Description	Dimensions in mm
W	Carrier Tape Width	8.0±0.3
P	Cavity Pitch	4.0±0.1
E	Perforation Position	1.75±0.1
F	Cavity to Perforation (Width Direction)	3.50±0.05
D	Perforation Diameter	1.5 <sup>+0.1/-0.0</sup>
D1	Cavity Hole Diameter	1.5 <sup>+0.1/-0.0</sup>
P0	Perforation Pitch	4.0±0.1
P1	Cavity to Perforation (Length Direction)	2.00±0.05
A0	Cavity Length	3.15±0.1
B0	Cavity Width	3.2±0.1
K0	Cavity Depth	1.4±0.1
t	Carrier Tape Thickness	0.20±0.03
C	Cover Tape Width	5.3±0.1

Copyright © 2010 by HOLTEK SEMICONDUCTOR INC.

The information appearing in this Data Sheet is believed to be accurate at the time of publication. However, Holtek assumes no responsibility arising from the use of the specifications described. The applications mentioned herein are used solely for the purpose of illustration and Holtek makes no warranty or representation that such applications will be suitable without further modification, nor recommends the use of its products for application that may present a risk to human life due to malfunction or otherwise. Holtek's products are not authorized for use as critical components in life support devices or systems. Holtek reserves the right to alter its products without prior notification. For the most up-to-date information, please visit our web site at <http://www.holtek.com.tw>.