

Feature

- High performance, low cost current mode PWM controller especially designed for energy star 5.0
- High-Voltage CMOS process with excellent ESD protection (>3KV)
- Very low startup current (<20 μ A) and operating current
- $\pm 5\%$ trimmed oscillator for precise frequency control
- Non-audible-noise Green Mode control
- LEB (Leading-Edge Blanking) on CS pin
- Internal slope compensation
- Programmable switching frequency
- Internally trimmed reference with UVLO (Under Voltage Lockout)
- Cycle-by-Cycle Current Limiting
- Build-in Short-Circuit-Protection(SCP) for Short-Circuit and Over-Load condition
- 8-Pin SOP package

General Description

The HT7A6002 is a high performance, low cost Current Mode PWM controller for providing necessary feature to implement Off-Line application. By Optimizing for the Energy Star 5.0 spec., the Power Supply Unit (PSU) implemented using the HT7A6002 can satisfy the “Energy Star No-Load Mode” Stand-by Power standard, which is less than 0.3W within all Nameplate Output Power Range of 0~250W. Internally implemented circuits include a trimmed Oscillator for precise frequency control, a temperature-compensated Voltage Reference, Slope Compensation, Leading-Edge Blanking, and a patented Non-Audible Noise Green Mode Control Scheme.

The HT7A6002 features a range of various protection functions such Short-Circuit Protection (SCP, which can also be used for Over-Load Protection, OLP), Cycle-by-Cycle Current Limiting and Under Voltage Lock-Out (UVLO).

Applications

- Switching AC-DC adaptor
- Open frames switching power supply
- LCD TV

Application Circuits

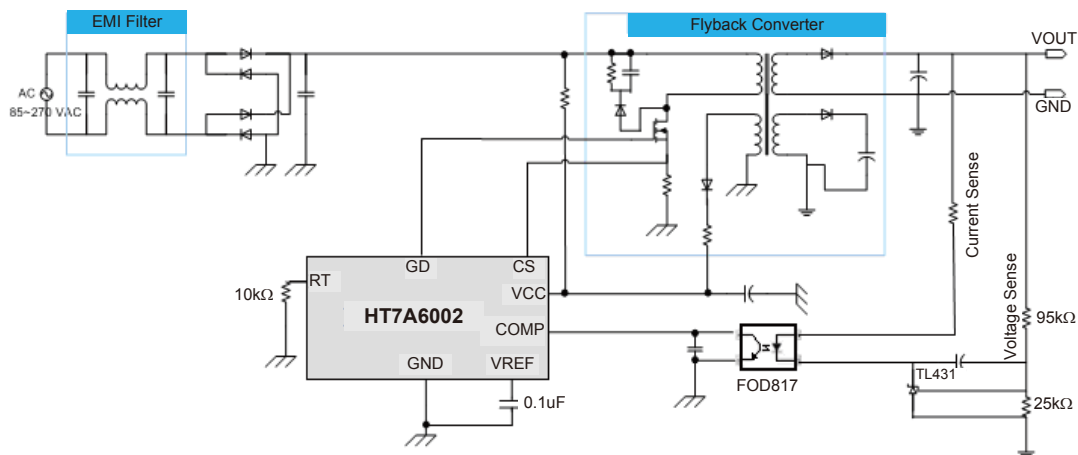

Block Diagram

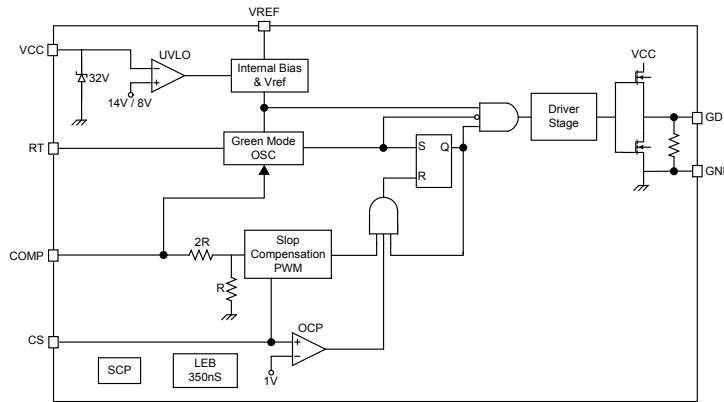

Pin Assignment

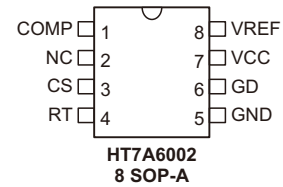

Pin Description

Pin No.	Pin Name	Description
1	COMP	Voltage Feedback Pin. Connected to a Photo-Coupler for close-loop control.
2	N.C	No connection
3	CS	A voltage proportional to inductor current is connected to this input. The PWM generator uses this voltage information to terminate the output switch conduction.
4	RT	The oscillator frequency is programmed by connecting a resistor RT between this pin and ground. A maximum frequency of 500KHz is possible.
5	GND	Combined control circuitry and power ground.
6	GD	Power MOSFET gate driver output.
7	VCC	Positive Supply.
8	VREF	Reference output.

Absolute Maximum Ratings

Supply Voltage VCC	-0.3V~30.0V
COMP, RT, CS Pins	-0.3V~5.5V
Junction Temperature	150°C
Operating Ambient Temperature	-40°C~85°C
Storage Temperature Range	-65°C~150°C
Package Thermal Resistance (8-Pin SOP)	160°C/W
ESD Protection:	
Human Body Model	3kV
Machine Model	200V

Note: These are stress ratings only. Stresses exceeding the range specified under “Absolute Maximum Ratings” may cause substantial damage to the device. Functional operation of this device at other conditions beyond those listed in the specification is not implied and prolonged exposure to extreme conditions may affect device reliability.

Electrical Characteristics

Unless otherwise stated, this specifications apply for $0^{\circ}\text{C} \leq T_a \leq 70^{\circ}\text{C}$, $V_{CC}=15\text{V}$, $R_T=10\text{k}\Omega$

Symbol	Parameter	Test Condition	Min.	Typ.	Max.	Unit
Supply Voltage (VCC Pin)						
I_{ST}	Startup Current	$V_{CC}=12.9\text{V}$	—	12	30	μA
I_{CC}	Operating Current	$V_{COMP}=0\text{V}$	—	2.0	3.0	mA
		$V_{COMP}=3\text{V}$	—	2.5	—	mA
V_{TL}	UVLO (Off)	—	7	8	9	V
V_{TH}	UVLO (On)	—	13	14	15	V
Reference Section						
V_{REF}	Output Voltage	$T_j = 25^{\circ}\text{C}$, $I_o = 1\text{mA}$	—	5.5	—	V
ΔV_{REF}	Line Regulation	$12\text{V} \leq V_{CC} \leq 25\text{V}$	—	3	20	mV
ΔV_{REF}	Load Regulation	$1\text{mA} \leq I_o \leq 10\text{mA}$	—	4	25	mV
Current Sensing (CS Pin)						
$V_{CS(OFF)}$	Maximum Input Voltage, $V_{cs(off)}$	—	0.9	1.0	1.1	V
t_{LEB}	Leading Edge Blanking Time	—	—	350	—	ns
	Delay to Output	—	—	100	—	ns
Oscillator (RT pin)						
f_{OSC}	Oscillator Frequency	$T_j=25^{\circ}\text{C}$, $R_T=10\text{k}\Omega$ (see note *)	49	52	55	kHz
$\frac{\Delta f_{OSC}}{\Delta T_A}$	Temp. Stability	$-40^{\circ}\text{C} \sim 105^{\circ}\text{C}$	—	5	—	$\%$
$\frac{\Delta f_{OSC}}{\Delta V_{REF}}$	Voltage Stability	$V_{CC}=10\text{V} \sim 25\text{V}$	—	0.2	1.0	$\%/V$
D_{MAX}	Maximum Duty	—	—	75	—	$\%$
Gate Drive Output (GD Pin)						
V_{OL}	Output Low Level	$V_{CC}=15\text{V}$, $I_{sink}=20\text{mA}$	—	—	1	V
V_{OH}	Output High Level	$V_{CC}=15\text{V}$, $I_{source}=20\text{mA}$	9	—	—	V
t_r	Rising Time	$T_j=25^{\circ}\text{C}$, Load Capacitance=1nF	—	50	150	ns
t_f	Falling Time	$T_j=25^{\circ}\text{C}$, Load Capacitance=1nF	—	50	150	ns
Voltage Feedback (COMP Pin)						
I_{SINK}	Short Circuit Current	$V_{COMP}=0\text{V}$	—	1.5	2.2	mA
V_{COMP}	Open Loop Voltage	COMP pin open	—	5.5	—	V
SCP (Short Circuit Protection)						
V_{COMP}	SCP Trip Level	V_{COMP} (SCP)	—	4.7	—	V
	SCP Delay Time (See Note)	$f_s=52\text{kHz}$	—	40	—	ms

Note: These Parameters, although guaranteed, are not 100% tested in production.

"*" Suggest to limit switching frequency under 75kHz for Green Mode operation.

Typical Performance Characteristics

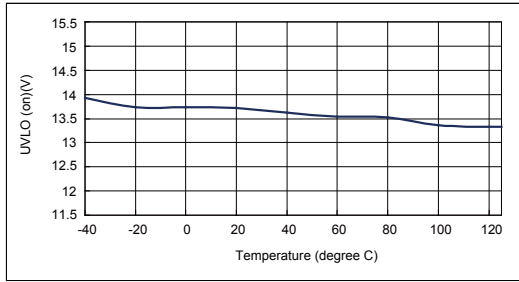

Figure 1. UVLO (on) (V) vs Temperature

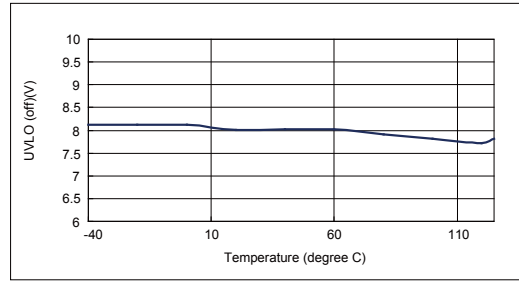

Figure 2. UVLO (off)(V) vs Temperature

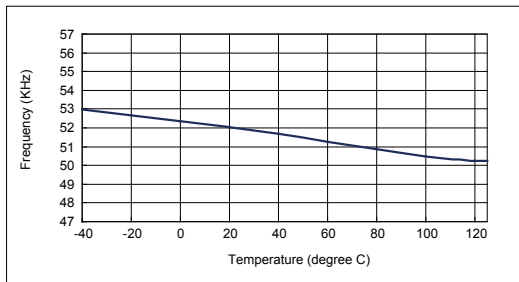

Figure 3. Frequency vs Temperature

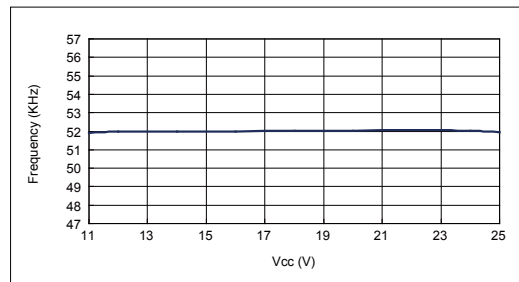

Figure 4. Frequency vs Vcc

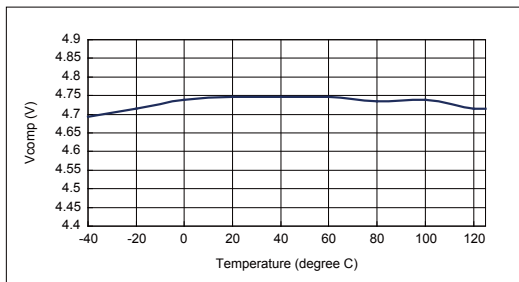

Figure 5. Vcomp for SCP vs Temperature

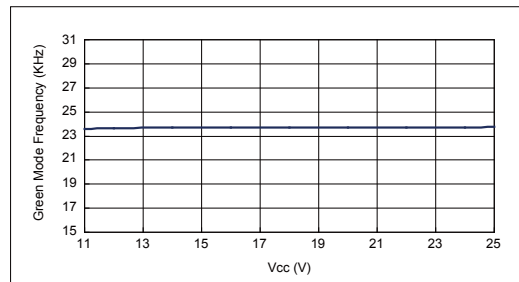

Figure 6. Green Mode Frequency vs Vcc

Application Information

Operation Overview

The HT7A6002 is an excellent, low power off-line PWM Controller. With a high degree of functional integration, the external component requirement is greatly reduced resulting in excellent performance/cost ratios. The device integrates many enhanced features such as a Non-Acoustic-Noise Green Mode Oscillator, Internal Slope Compensation, Internal Leading-Edge Blanking, Short-Circuit Protection and a wide industrial operating temperature range (-40°C to 85°C). The device is designed for primary side control / secondary side feedback applications and is optimized for the Energy Star 5.0 specification, this ensures that any EPS (External Power Supply) implemented using the HT7A6002 can fully satisfy the Energy Star 1.1/2.0 Stand-by (No-Load) criteria.

Energy Consumption Criteria for No-Load

Nameplate Output Power (P_{no})	Maximum Power in No-Load	
	AC-AC EPS	AC-DC EPS
0 to < 50 watts	≤ 0.5 watts	≤ 0.3 watts
≥ 50 to ≤ 250 watts	≤ 0.5 watts	≤ 0.3 watts

Table 1. Energy Star 5.0 No-Load Criteria

Ultra Low Stand-by Power for Energy Star 5.0 and Later Energy Star Requirement

The device contains many advanced control schemes for Low Stand-by Power like tiny Operating/Stand-by Current, Green Mode for Light-Load, etc. By choosing an appropriate Stand-by resistor (as shown in Figure 7), EPS implemented by the device can fully satisfy the Energy Star 5.0 No-Load criteria.

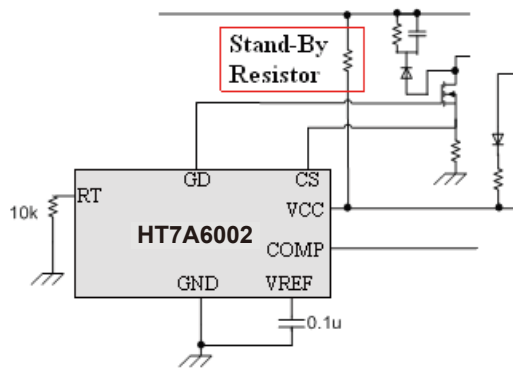

Figure 7. Stand-by Resistor

Base on device field test demo board results, for the Full-Range (115V, 230V Vac) input, the Stand-by Power will remain less than 0.3W@ $P_{no}=60W$ (as shown in Table 2). This is within the Energy Star 5.0 criteria.

	Input Range	Stand-by Power
Demo Board Input Condition ($P_{no}=60$ watts)	115V V_{AC}	< 0.3W
	230V V_{AC}	< 0.3W

Table 2. Demo Board Stand-by Power Results

Advanced Precise-Oscillator for Green-Mode Switching and Non-Acoustic Noise Requirement

A Trimmed Precise Green Mode Oscillator is implemented in the device to enhance the conversion efficiency under conditions of light loads. As the data shown in Fig. 8, the efficiency difference of the traditional current mode PWM Controller between light loads and heavy loads is more than 8%, while the average efficiency is only 82%, the efficiency difference of the HT7A6002 is only 1%, while average efficiency is up to 87.5%.

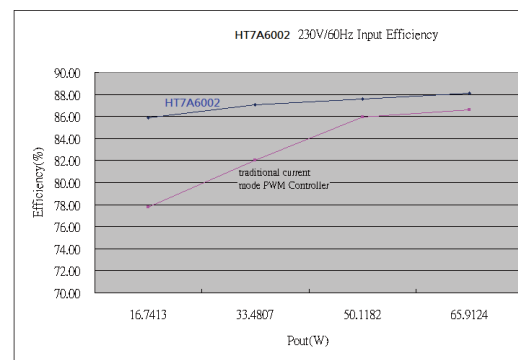
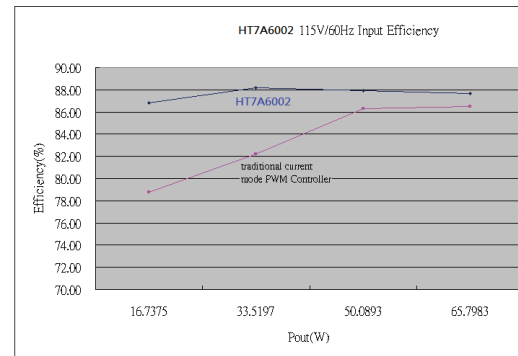

Figure 8. Efficiency Comparison between HT7A6002 & Traditional Current Mode PWM Controller (Measured at HT7A6002 Demo Board)

The Green Mode Oscillator types supplied by other PWM Controller providers are plagued by the problems of Acoustic-Noise. This is because, under the conditions of light loads, the frequency will keep decreasing through Human Acoustic Range (from 20Hz to 20kHz), these audio frequencies may create audible noise in the transformer. Holtek's HT7A6002 patented Green Mode Oscillator designed using an advanced Non-Acoustic Noise Scheme to prevent the generation of frequencies in the audio frequency band, thus eliminating any transformer noise.

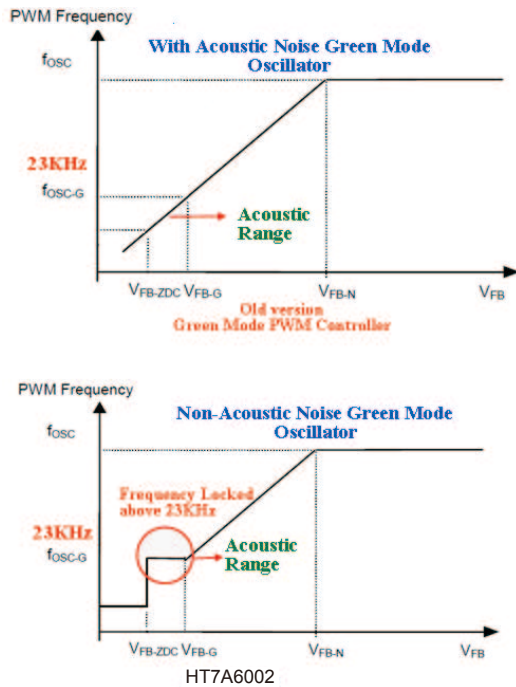

Figure 9. Oscillator Behavior Compared with HT7A6002 and other Green Mode PWM Controller

Under Voltage Lockout (UVLO)

An UVLO comparator is implemented in to ensure that the device is fully functional before the output stage is enabled. As shown in Fig. 10, a hysteresis is provided to prevent the PWM Controller from shutting down during any voltage dips which might occur during startup process. The turn-on and turn-off threshold levels are set at 16.0V and 10.0V, respectively.

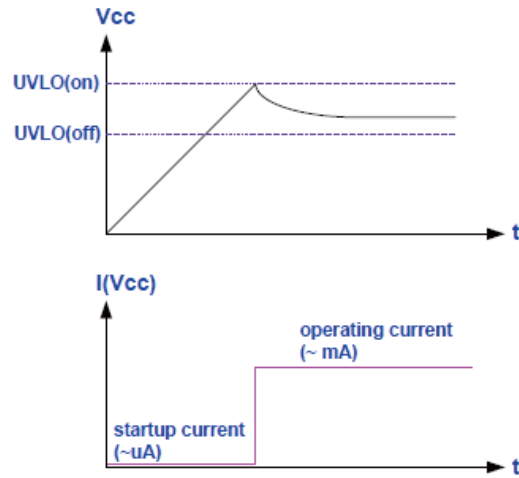

Figure 10. UVLO Scheme and Start-Up Current

Current Sense and Leading-Edge Blanking (LEB)

A Leading-Edge Blanking Scheme is integrated in the device to prevent false triggering due to feedback current spikes which may appear on the CS pin, further eliminate the need for R-C filter which is always a requirement in the traditional current mode PWM Controller applications.

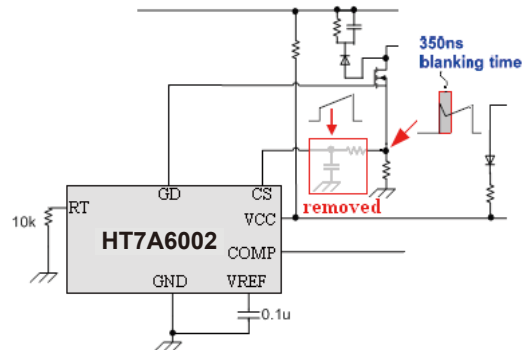

Figure 11. LEB with R-C Filter Removed

Internal Slope-Compensation

An important issue with the current mode control schemes is the instability due to Sub-Harmonic Oscillation when the Duty-Cycle > 50%. To prevent this problem from occurring, a Slope-Compensation function is always necessary. In traditional current mode PWM Controller application, many external components are necessary for Slope-Compensation function, but in HT7A6002 the internal Slope-Compensation eliminates the need for these external components resulting in simplified the application circuit design.

Short-Circuit Protection (SCP) and Over-Load Protection (OLP)

To protect all the devices of a system from being damaged under over load or short circuit conditions, a smart SCP function is implemented in the device. Here the feedback system will force the voltage loop to move toward a saturation value and then pull up the voltage on the COMP pin. Whenever the VCOMP increases to the SCP threshold of 4.7V and remains there for longer than 40ms, the protection scheme will activate and then turn off the gate output to stop the switching of power circuit. By using such a protection mechanism, the average input power can be reduced to a very low level so that the component temperature and stress can be controlled within safe operating levels.

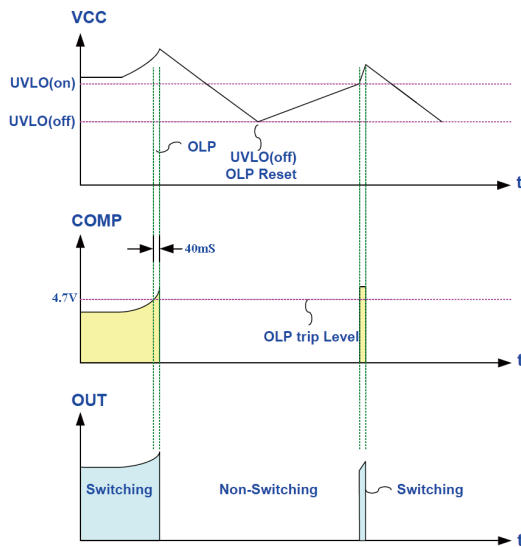

Figure 12. SCP Function Behavior

Oscillator Frequency Tuning

By choosing an appropriate value of an external resistor between the RT Pin and GND, a suitable operating frequency can be generated. The relationship between the value of R_T and the operating frequency is provided in the Figure 13.

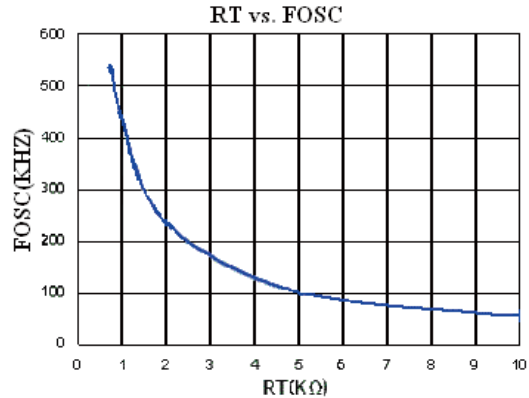
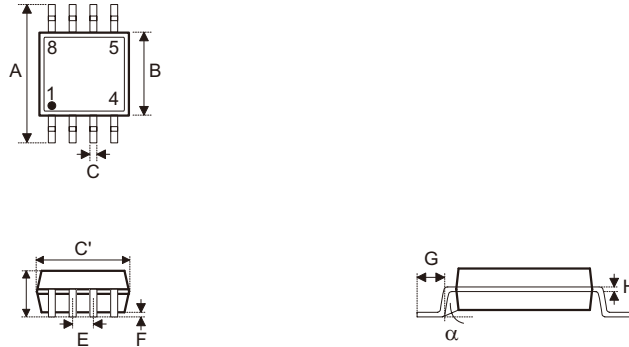

Figure 13. RT Resistor value vs Operating Frequency

Package Information

Note that the package information provided here is for consultation purposes only. As this information may be updated at regular intervals users are reminded to consult the Holtek website (<http://www.holtek.com.tw/english/literature/package.pdf>) for the latest version of the package information.

8-pin SOP (150mil) Outline Dimensions



MS-012

Symbol	Dimensions in inch		
	Min.	Nom.	Max.
A	0.228	—	0.244
B	0.150	—	0.157
C	0.012	—	0.020
C'	0.188	—	0.197
D	—	—	0.069
E	—	0.050	—
F	0.004	—	0.010
G	0.016	—	0.050
H	0.007	—	0.010
α	0°	—	8°

Symbol	Dimensions in mm		
	Min.	Nom.	Max.
A	5.79	—	6.20
B	3.81	—	3.99
C	0.30	—	0.51
C'	4.78	—	5.00
D	—	—	1.75
E	—	1.27	—
F	0.10	—	0.25
G	0.41	—	1.27
H	0.18	—	0.25
α	0°	—	8°

Reel Dimensions

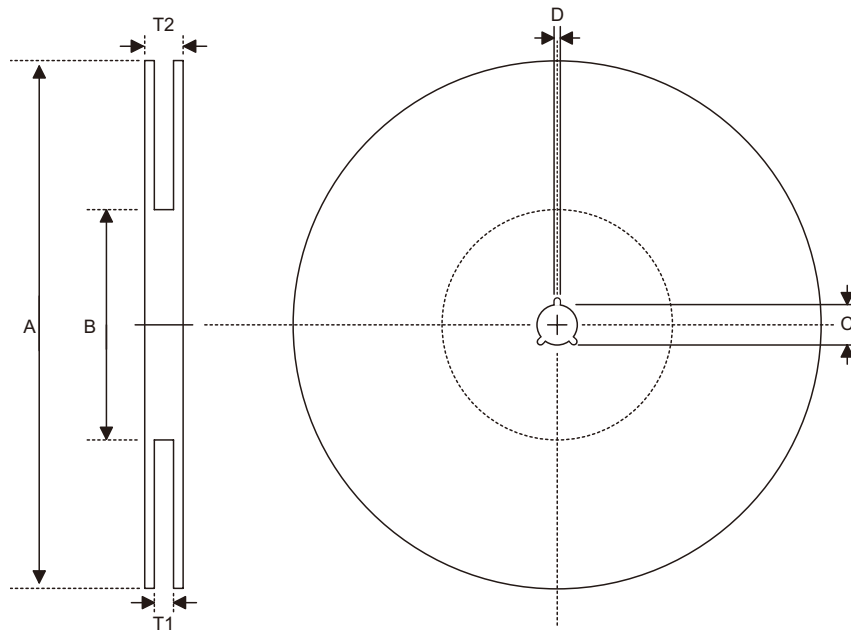

SOP 8N (150mil)

Symbol	Description	Dimensions in mm
A	Reel Outer Diameter	330.0±1.0
B	Reel Inner Diameter	100.0±1.5
C	Spindle Hole Diameter	13.0 ^{+0.5/-0.2}
D	Key Slit Width	2.0±0.5
T1	Space Between Flange	12.8 ^{+0.3/-0.2}
T2	Reel Thickness	18.2±0.2

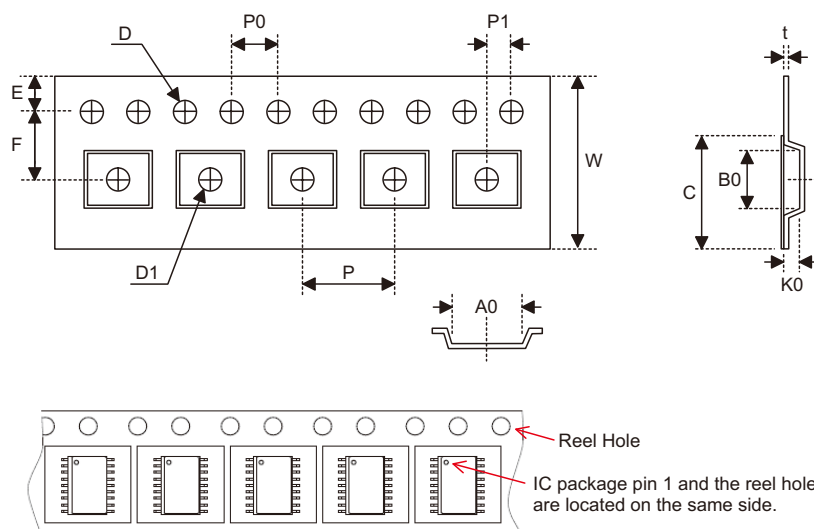
Carrier Tape Dimensions

SOP 8N (150mil)

Symbol	Description	Dimensions in mm
W	Carrier Tape Width	12.0 ^{+0.3/-0.1}
P	Cavity Pitch	8.0±0.1
E	Perforation Position	1.75±0.10
F	Cavity to Perforation (Width Direction)	5.5±0.1
D	Perforation Diameter	1.55±0.1
D1	Cavity Hole Diameter	1.50 ^{+0.25/-0.00}
P0	Perforation Pitch	4.0±0.1
P1	Cavity to Perforation (Length Direction)	2.0±0.1
A0	Cavity Length	6.4±0.1
B0	Cavity Width	5.2±0.1
K0	Cavity Depth	2.1±0.1
t	Carrier Tape Thickness	0.30±0.05
C	Cover Tape Width	9.3±0.1

Holtek Semiconductor Inc. (Headquarters)

No.3, Creation Rd. II, Science Park, Hsinchu, Taiwan
Tel: 886-3-563-1999
Fax: 886-3-563-1189
<http://www.holtek.com.tw>

Holtek Semiconductor Inc. (Taipei Sales Office)

4F-2, No. 3-2, YuanQu St., Nankang Software Park, Taipei 115, Taiwan
Tel: 886-2-2655-7070
Fax: 886-2-2655-7373
Fax: 886-2-2655-7383 (International sales hotline)

Holtek Semiconductor (China) Inc. (Dongguan Sales Office)

Building No.10, Xinzhu Court, (No.1 Headquarters), 4 Cuizhu Road, Songshan Lake, Dongguan, China 523808
Tel: 86-769-2626-1300
Fax: 86-769-2626-1311, 86-769-2626-1322

Holtek Semiconductor (USA), Inc. (North America Sales Office)

46729 Fremont Blvd., Fremont, CA 94538, USA
Tel: 1-510-252-9880
Fax: 1-510-252-9885
<http://www.holtek.com>

Copyright© 2012 by HOLTEK SEMICONDUCTOR INC.

The information appearing in this Data Sheet is believed to be accurate at the time of publication. However, Holtek assumes no responsibility arising from the use of the specifications described. The applications mentioned herein are used solely for the purpose of illustration and Holtek makes no warranty or representation that such applications will be suitable without further modification, nor recommends the use of its products for application that may present a risk to human life due to malfunction or otherwise. Holtek's products are not authorized for use as critical components in life support devices or systems. Holtek reserves the right to alter its products without prior notification. For the most up-to-date information, please visit our web site at <http://www.holtek.com.tw>.