

Feature

- Input voltage range: 4.75V to 24V
- Variable output voltage range: 1.222V to 20V
- 3A output current
- Efficiency up to 91%
- Fixed 380kHz operating frequency
- 20 μ A shutdown current
- Internal power MOSFET switch
- Stable operation using low ESR ceramic capacitors
- Over temperature protection
- Cycle-by-cycle over current protection
- Soft-start function
- Under voltage lockout protection
- 8-pin SOP package

Applications

- Battery chargers
- Distributed power systems
- LED power supplies
- DSL modems
- Linear regulator pre power processing
- Set-Top-Boxes, DVD players, LCD displays

General Description

The HT7466 is a DC-DC buck regulator. The built-in high driver NMOS provides a monolithic solution for high efficiency step-down DC-DC converter. With 3A output current, the wide input voltage range and stable output voltage regulation can widely use in all kinds of application, like communication, power for high power LED, battery charger, etc. The protection function include over current and over temperature protection. The soft start function prevent inrush supply current and output overshoot when initial startup. The under voltage lockout is set to 4.1V. It prevents abnormal situation occurring.

The HT7466 requires a minimum number of standard external components and is available in a 8-pin SOP package for small area PCB application.

Application Circuit

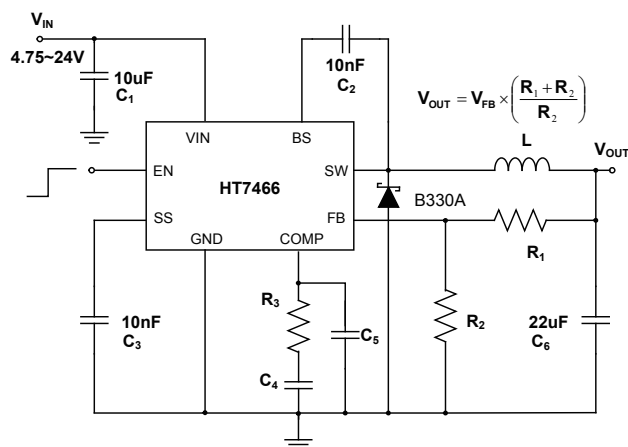

Efficiency vs Output Current

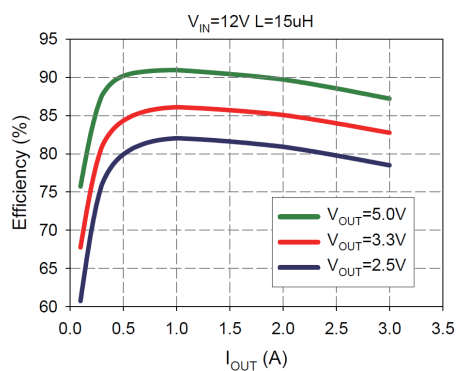

Block Diagram

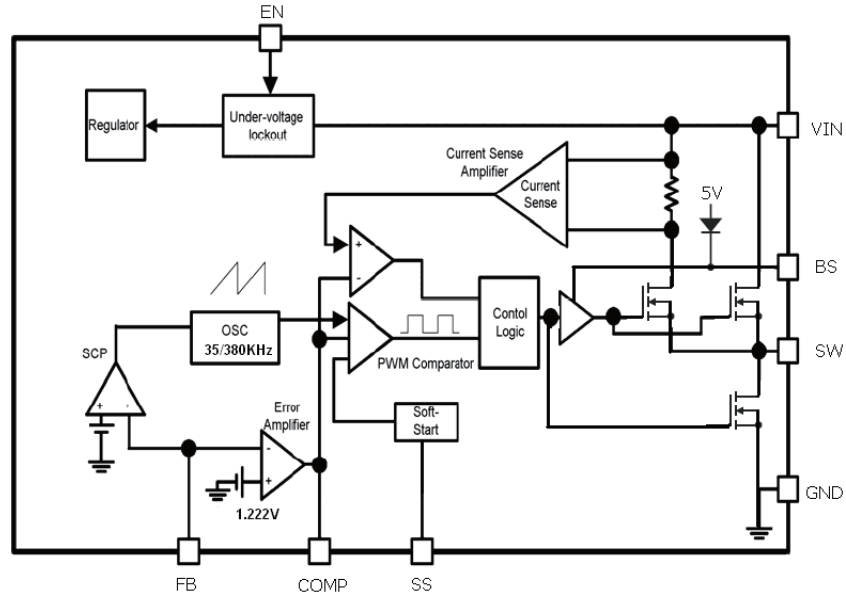

Pin Assignment

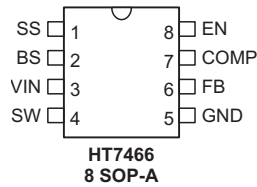

Pin Description

Pin No.	Pin Name	Description
1	SS	Soft-start input. If the soft start function is to be used then an external capacitor should be connected between this pin and ground. If the soft start function is not required the pin should be left open.
2	BS	Internal power NMOS gate drive boost input. A 10nF or greater value capacitor should be connected from SW to BS for additional Power NMOS gate driving purposes.
3	VIN	Power supply input. The input supply pin for the device, VIN, is connected to a supply voltage between 4.75V to 24V.
4	SW	Power switching output. The internal power MOS drain is connected to the inductor, diode and VIN.
5	GND	Ground. Device ground voltage reference.
6	FB	Feedback pin. The feedback pin is connected to an external resistor divider to measure the output voltage.
7	COMP	Error amplifier output. Used for compensation of the regulation control loop. Connect a series RC network from COMP to GND to compensate the regulation control loop. The COMP pin value is 1.222V.
8	EN	Enable input. This pin is set high to turn on the regulator and low to turn it off. The pin should be left unconnected if not used.

Absolute Maximum Ratings

Maximum Input Supply Voltage.....	26V	Comp Voltage.....	6V
Switch Node Voltage.....	26V	SS Voltage.....	6V
Feedback Voltage.....	6V	Maximum Junction Temperature.....	150°C
EN Voltage.....	6V		

Note: These are stress ratings only. Stresses exceeding the range specified under “Absolute Maximum Ratings” may cause substantial damage to the device. Functional operation of this device at other conditions beyond those listed in the specification is not implied and prolonged exposure to extreme conditions may affect device reliability.

Recommended Operating Conditions

Input Supply Voltage.....	4.75V ~ 24V	Ambient Temperature Range.....	-40°C ~ +85°C
---------------------------	-------------	--------------------------------	---------------

Electrical Characteristics

$V_{IN}=12V$, $T_a=25^\circ C$, unless otherwise specified refer to circuit of Figure 1. (note 1)

Symbol	Parameter	Test Condition	Min.	Typ.	Max.	Unit
V_{FB}	Feedback Voltage	$4.75V \leq V_{IN} \leq 24V$	1.194	1.222	1.250	V
V_{UVLO}	Under Voltage Lockout Threshold	—	—	4.1	—	V
—	Under Voltage Lockout Threshold Hysteresis	—	—	200	—	mV
I_Q	Quiescent Current	$V_{FB}=1.5V$, $V_{EN}=High$	—	1.0	1.2	mA
I_{SS}	Shutdown Supply Current	$V_{EN}=0V$	—	20	30	μA
F_{OSC}	Oscillator Frequency	—	—	380	—	kHz
—	Short Circuit Frequency	$V_{FB}=0V$	20	35	50	kHz
D_{MAX}	Maximum Duty Cycle	$V_{FB}=1.0V$	—	90	—	%
I_{SW}	Upper Switch Leakage	$V_{EN}=0V$, $V_{SW}=0V$	—	0	10	μA
R_{DS}	Switch On Resistance (note 2)	$I_{OUT}=3A$	—	95	—	$m\Omega$
I_{LIMIT}	Current Limit	—	—	4.3	—	A
—	Error Amplifier Voltage Gain (note 2)	—	—	70	—	dB
—	Error Amplifier Trans-conductance (note 2)	—	—	800	—	$\mu A/V$
V_{EN}	Enable Threshold	$4.75V \leq V_{IN} \leq 24V$	0.9	1.0	1.5	V
T_J	Thermal Shutdown	—	—	150	—	$^\circ C$

Note: 1. Specifications are production tested at T_a =room temperature. Specifications over the $-40^\circ C$ to $85^\circ C$ operating temperature range are assured by design, characterization and correlation with Statistical Quality Controls (SQC).

2. Designer test specifications.

Functional Description

Setting the Output Voltage

The HT7466 is a step down switching DC/DC converter device. The device switching output, SW, is connected to a standard converter LC filter circuit for buck conversion. The output current is sensed using an external voltage divider network connected to the load output voltage and ground, and the sense voltage feedback to the device on the FB pin. By comparing this sense voltage with an internally generated 1.222 voltage reference, suitable regulation can be implemented to achieve the required output voltage. By selecting suitable values of external voltage divider resistors, the desired output voltage can be adjusted to the required level. The output voltage can be calculated using the following formula:

$$V_{OUT} = \frac{R_1 + R_2}{R_2} \times 1.222$$

Where R2 is the resistor divider lower resistor and R1 is the upper resistor, and the R1, R2 must be kΩ level.

Compensation Components

Care must be taken when selecting external components. The COMP pin is the output of the error amplifier and must be properly connected to an external RC network to ensure regulator loop stability. The values of the compensation components given in Table 1 yield a stable control loop for the output voltage and capacitor given.

Table 1 Compensation Values for Typical Output Voltage/Capacitor Combinations.

V _{OUT}	L	R3	C4	R1	R2	C6	C5
2.5V	15μH	3.9kΩ	5.6nF	10.5kΩ	10kΩ	22μF Ceramic	—
3.3V	15μH	4.7kΩ	4.7nF	17.0kΩ	10kΩ	22μF Ceramic	—
5.0V	15μH	7.5kΩ	2.7nF	30.9kΩ	10kΩ	22μF Ceramic	—

Bootstrap Circuit

In this device bootstrap capacitor is connected from SW to BS pin, the Step-Down converter is use N-Channel MOSFET, and MOS source pin is floating to ground, this drive circuit of the application is called high-side circuit, and the drive circuit used in this kind of situation is called bootstrap circuit. Large capacitor values can keep internal high-side N-Channel MOSFET gate voltage greater than zero when power MOS is turn on; usually a 10nF capacitor is sufficient for most applications.

Current Limit Protection

The device has a cycle-by-cycle current limit to protect the internal power MOSFET. If the inductor current reaches the current limit threshold of 4.3A, the MOSFET oscillator frequency will be transformed from 380kHz to a short circuit frequency of 35kHz and the output current will remain at its current limit value.

Over Temperature Protection

A thermal shutdown is implemented to prevent damage due to excessive heat and power dissipation. Typically the thermal shutdown threshold is 150°C. The thermal shutdown is triggered the device stops switching and when the device thermal falls until the temperature hysteresis windows the device will be starts switching again.

Application Information

Inductor

The inductor is required to supply a constant current to the output load while being driven by the switched input voltage. The choice of inductor affects steady state operation as well as transient behavior and loop stability. There are three important electrical parameters which need to be considered when choosing an inductor:

- The inductor value
- DCR - copper wire resistance
- The saturation current

Inductor choice is especially important as it is important to ensure the inductor does not saturate under its peak current conditions, the general rule of keeping the inductor current peak-to-peak ripple approximately 30% of the nominal output current. Using this value of ripple current is a good compromise between excessive output voltage ripple and excessive component size and cost. Also ensure that the inductor has a low DCR to minimize power losses.

Input/Output Capacitor

Input Capacitor

Because the Vin pin is connected to the internal power MOSFET, when the power MOSFET is switching and the input current is discontinuous, therefore an input capacitor C1 (in PCB layout C1 and C8 is paralleled input capacitor) is required to supply the AC current to the step-down converter while maintaining the DC input voltage. A low ESR ceramic capacitor is required to keep noise to a minimum.

Output Capacitor

The output capacitor is required to maintain the DC output voltage. Ceramic or low ESR electrolytic capacitors is the rule to choice of external load capacitor is also critical and low ESR value capacitors must be used to ensure stability. This capacitor must be connected very close to the inductor, with short traces for good noise performance.

Schottky Diode

The output diode conducts when the internal power MOSFET is switched off. There are three important electrical parameters to consider when choosing the diode:

- The diode maximum reverse voltage value must be greater than the maximum input voltage.
- Short recovery time and low forward voltage -- use a schottky diode type.
- Diode current rating should be greater than the maximum load current.

Layout Considerations

Circuit board layout is a very important consideration for switching regulators if they are to function properly. Poor circuit layout may result in related noise problems. In order to minimise EMI and switching noise, follow the guidelines below:

- All tracks should be as wide as possible.
- The input and output capacitors, C1 (C8) and C6 (C7), should be placed close to the VIN, VOUT and GND pins (C1 and C8 is parallel; C6 and C7 is parallel).
- The Schottky diode D and inductor L must be placed close to the SW pin.
- Feedback resistor, R1 (R1-1) and R2, must be placed close to the FB and GND pins (R1 and R1-1 is series).
- A full ground plane is always helpful for better EMI performance.

A recommended PCB layout with component locations is shown below.

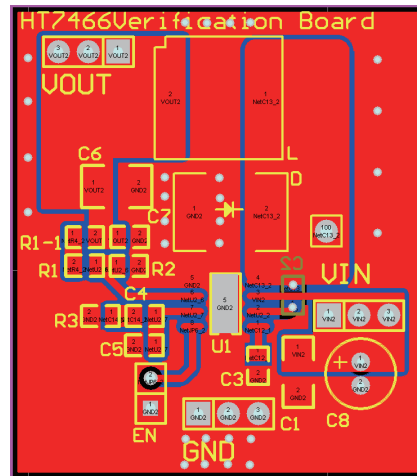

Top Layer

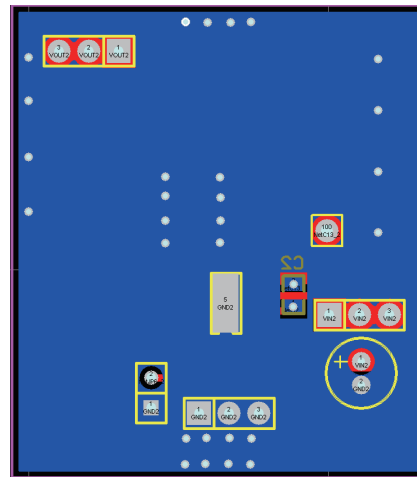

Bottom Layer

Package Information

Note that the package information provided here is for consultation purposes only. As this information may be updated at regular intervals users are reminded to consult the Holtek website (<http://www.holtek.com.tw/english/literature/package.pdf>) for the latest version of the package information.

8-pin SOP (150mil) Outline Dimensions for Thermally Enhanced Variations Only (Exposed Pad)

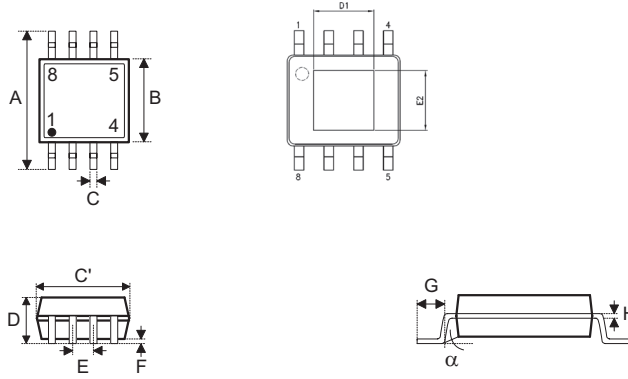
MS-012

Symbol	Dimensions in inch		
	Min.	Nom.	Max.
A	—	0.236	
B	—	0.154	
C	0.012	—	0.020
C'	—	0.193	
D	—	—	0.067
D1	0.059	—	—
E	—	0.050	—
E2	0.039	—	—
F	—	—	0.006
G	0.016	—	0.050
H	0.004	—	0.010
α	0°	—	8°

Symbol	Dimensions in mm		
	Min.	Nom.	Max.
A	—	6.00	—
B	—	3.90	—
C	0.31	—	0.51
C'	—	4.90	—
D	—	—	1.70
D1	1.50	—	—
E	—	1.27	—
E2	1.00	—	—
F	—	—	0.15
G	0.40	—	1.27
H	0.10	—	0.25
α	0°	—	8°

Reel Dimensions

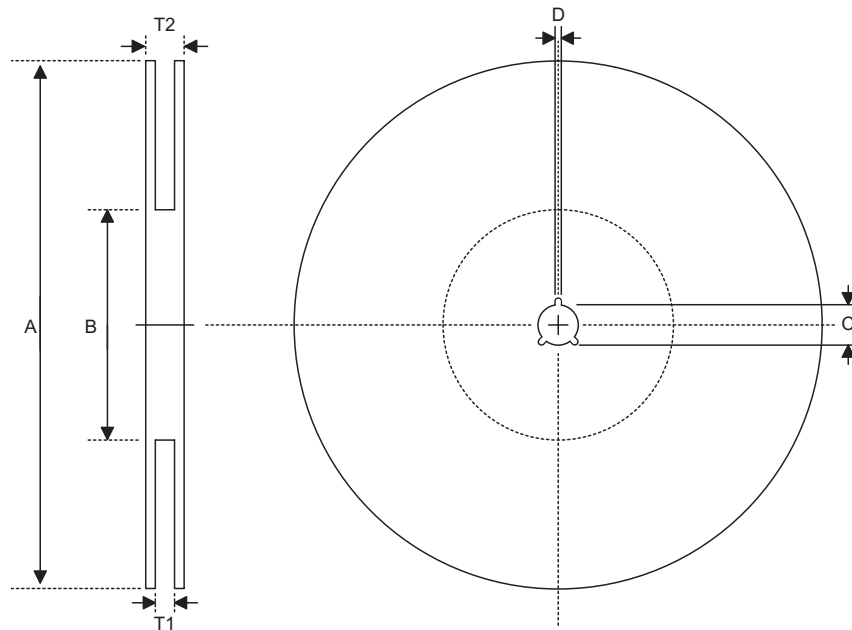

SOP 8N (150mil)

Symbol	Description	Dimensions in mm
A	Reel Outer Diameter	330.0±1.0
B	Reel Inner Diameter	100.0±1.5
C	Spindle Hole Diameter	13.0 ^{+0.5/-0.2}
D	Key Slit Width	2.0±0.5
T1	Space Between Flange	12.8 ^{+0.3/-0.2}
T2	Reel Thickness	18.2±0.2

Carrier Tape Dimensions

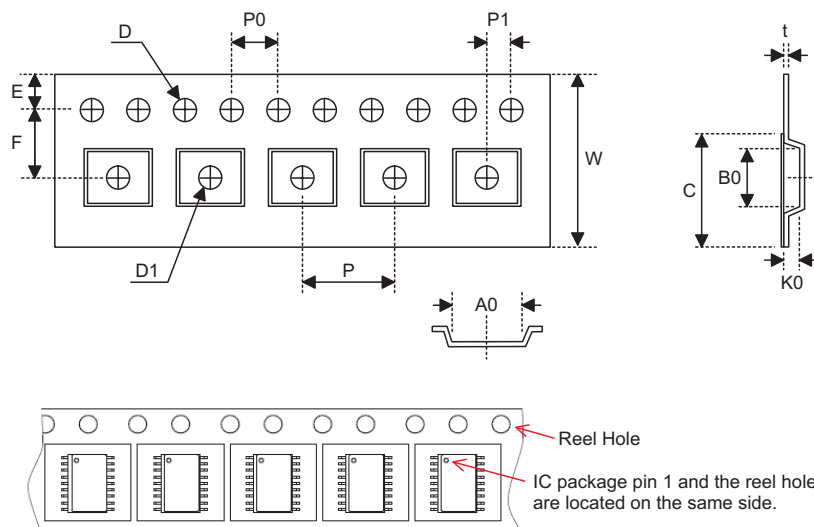

SOP 8N (150mil)

Symbol	Description	Dimensions in mm
W	Carrier Tape Width	12.0 ^{+0.3/-0.1}
P	Cavity Pitch	8.0±0.1
E	Perforation Position	1.75±0.10
F	Cavity to Perforation (Width Direction)	5.5±0.1
D	Perforation Diameter	1.55±0.1
D1	Cavity Hole Diameter	1.50 ^{+0.25/-0.00}
P0	Perforation Pitch	4.0±0.1
P1	Cavity to Perforation (Length Direction)	2.0±0.1
A0	Cavity Length	6.4±0.1
B0	Cavity Width	5.2±0.1
K0	Cavity Depth	2.1±0.1
t	Carrier Tape Thickness	0.30±0.05
C	Cover Tape Width	9.3±0.1

Holtek Semiconductor Inc. (Headquarters)

No.3, Creation Rd. II, Science Park, Hsinchu, Taiwan
Tel: 886-3-563-1999
Fax: 886-3-563-1189
<http://www.holtek.com.tw>

Holtek Semiconductor Inc. (Taipei Sales Office)

4F-2, No. 3-2, YuanQu St., Nankang Software Park, Taipei 115, Taiwan
Tel: 886-2-2655-7070
Fax: 886-2-2655-7373
Fax: 886-2-2655-7383 (International sales hotline)

Holtek Semiconductor (China) Inc. (Dongguan Sales Office)

Building No.10, Xinzhu Court, (No.1 Headquarters), 4 Cuizhu Road, Songshan Lake, Dongguan, China 523808
Tel: 86-769-2626-1300
Fax: 86-769-2626-1311, 86-769-2626-1322

Holtek Semiconductor (USA), Inc. (North America Sales Office)

46729 Fremont Blvd., Fremont, CA 94538, USA
Tel: 1-510-252-9880B
Fax: 1-510-252-9885
<http://www.holtek.com>

Copyright© 2011 by HOLTEK SEMICONDUCTOR INC.

The information appearing in this Data Sheet is believed to be accurate at the time of publication. However, Holtek assumes no responsibility arising from the use of the specifications described. The applications mentioned herein are used solely for the purpose of illustration and Holtek makes no warranty or representation that such applications will be suitable without further modification, nor recommends the use of its products for application that may present a risk to human life due to malfunction or otherwise. Holtek's products are not authorized for use as critical components in life support devices or systems. Holtek reserves the right to alter its products without prior notification. For the most up-to-date information, please visit our web site at <http://www.holtek.com.tw>.