

Features

- Low power consumption
- Low temperature coefficient
- High input voltage range (up to 24V)
- Output voltage accuracy: tolerance $\pm 1\%$
- Built-in hysteresis characteristic
- TO92, SOT89 and SOT23-5 package

Applications

- Battery checkers
- Level selectors
- Power failure detectors
- Microcomputer reset
- Battery memory backup
- Non-volatile RAM signal storage protectors

General Description

The HT70xxA-2 series devices are a set of three terminal low power voltage detectors implemented in CMOS technology. Each voltage detector in the series detects a particular fixed voltage ranging from 2.2V to 8.2V. The voltage detectors consist of a high-precision and low power consumption standard voltage source as well as a

comparator, hysteresis circuit, and an output driver. CMOS technology ensures low power consumption.

Although designed primarily as fixed voltage detectors, these devices can be used with external components to detect user specified threshold voltages.

Selection Table

Part No.	Detectable Voltage	Hysteresis Width	Tolerance	Package	Marking
HT7022A-2	2.2V	0.110V	$\pm 1\%$	TO92 SOT89 SOT23-5	70xxA-2 (for TO92) 70xxA-2# (for SOT89) 70xxA-2+ (for SOT89) xxA2# (for SOT23-5) xxA2+ (for SOT23-5)
HT7024A-2	2.4V	0.120V			
HT7027A-2	2.7V	0.135V			
HT7033A-2	3.3V	0.165V			
HT7039A-2	3.9V	0.195V			
HT7044A-2	4.4V	0.220V			
HT7050A-2	5.0V	0.250V			
HT7082A-2	8.2V	0.410V			

Note: "xx" stands for output voltages.

Both lead free and green compound devices are available. Note the symbol marks below:

"#" stands for lead free devices.

"+" stands for green compound devices, which are Lead-free and Halogen-free.

For the TO92 package, the symbol mark will be at the end of the date code. Whereas for the SOT89 and SOT23-5, the symbol mark will be located at the end of IC marking.

Block Diagram

N Channel Open Drain Output (Normal Open; Active Low)

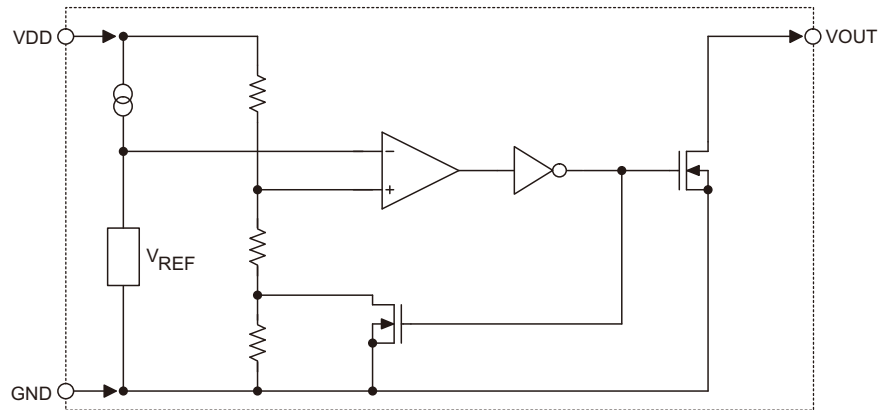

Output Table & Curve

V _{DD}	V _{DD} > V _{DET} (+)	V _{DD} ≤ V _{DET} (-)
V _{OUT}	Hi-Z	VSS

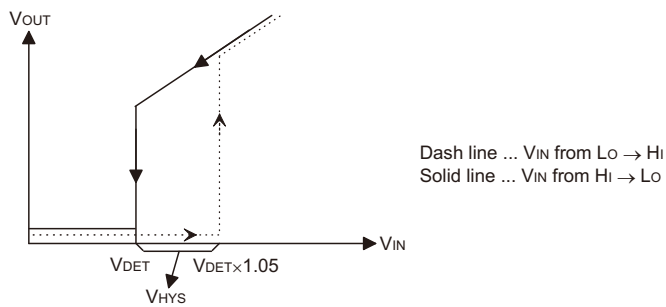

Pin Assignment

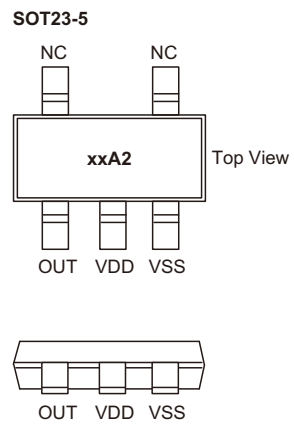
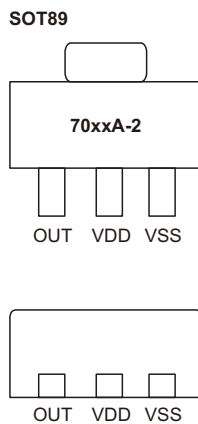
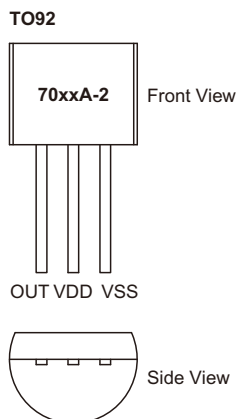

Absolute Maximum Ratings

Supply Voltage	$V_{SS}-0.3V$ to $V_{SS}+26V$		
Output Voltage	$V_{SS}-0.3V$ to $V_{DD}+0.3V$	Output Current.....	50mA
Storage Temperature	-50°C to 125°C	Power Consumption	200mW
Operating Temperature	-40°C to 85°C		

Note: These are stress ratings only. Stresses exceeding the range specified under "Absolute Maximum Ratings" may cause substantial damage to the device. Functional operation of this device at other conditions beyond those listed in the specification is not implied and prolonged exposure to extreme conditions may affect device reliability.

Electrical Characteristics
HT7022A-2
 $T_a=25^{\circ}C$

Symbol	Parameter	Test Conditions		Min.	Typ.	Max.	Unit
		V_{DD}	Conditions				
V_{DET}	Detection Voltage	—	—	2.178	2.200	2.222	V
V_{HYS}	Hysteresis Width	—	—	0.02 V_{DET}	0.05 V_{DET}	0.10 V_{DET}	V
I_{DD}	Operating Current	3.2V	No load	—	3	6	μA
V_{DD}	Operating Voltage	—	—	2.1	—	24	V
I_{OL}	Output Sink Current	2V	$V_{OUT}=0.2V$	0.5	1.0	—	mA
$\frac{\Delta V_{DET}}{\Delta T_a}$	Temperature Coefficient	—	-40°C< T_a <85°C	—	± 100	—	ppm

HT7024A-2
 $T_a=25^{\circ}C$

Symbol	Parameter	Test Conditions		Min.	Typ.	Max.	Unit
		V_{DD}	Conditions				
V_{DET}	Detection Voltage	—	—	2.376	2.400	2.424	V
V_{HYS}	Hysteresis Width	—	—	0.02 V_{DET}	0.05 V_{DET}	0.10 V_{DET}	V
I_{DD}	Operating Current	3.4V	No load	—	3	6	μA
V_{DD}	Operating Voltage	—	—	2.1	—	24	V
I_{OL}	Output Sink Current	2V	$V_{OUT}=0.2V$	0.5	1.0	—	mA
$\frac{\Delta V_{DET}}{\Delta T_a}$	Temperature Coefficient	—	-40°C< T_a <85°C	—	± 100	—	ppm

HT7027A-2

Ta=25°C

Symbol	Parameter	Test Conditions		Min.	Typ.	Max.	Unit
		V _{DD}	Conditions				
V _{DET}	Detection Voltage	—	—	2.673	2.700	2.727	V
V _{HYS}	Hysteresis Width	—	—	0.02 V _{DET}	0.05 V _{DET}	0.10 V _{DET}	V
I _{DD}	Operating Current	3.7V	No load	—	3	6	μA
V _{DD}	Operating Voltage	—	—	2.1	—	24	V
I _{OL}	Output Sink Current	2V	V _{OUT} =0.2V	0.5	1.0	—	mA
$\frac{\Delta V_{DET}}{\Delta T_a}$	Temperature Coefficient	—	-40°C<T _a <85°C	—	±100	—	ppm

HT7033A-2

Ta=25°C

Symbol	Parameter	Test Conditions		Min.	Typ.	Max.	Unit
		V _{DD}	Conditions				
V _{DET}	Detection Voltage	—	—	3.267	3.300	3.333	V
V _{HYS}	Hysteresis Width	—	—	0.02 V _{DET}	0.05 V _{DET}	0.10 V _{DET}	V
I _{DD}	Operating Current	4.3V	No load	—	3	6	μA
V _{DD}	Operating Voltage	—	—	2.1	—	24	V
I _{OL}	Output Sink Current	2.5V	V _{OUT} =0.25V	1.2	2.5	—	mA
$\frac{\Delta V_{DET}}{\Delta T_a}$	Temperature Coefficient	—	-40°C<T _a <85°C	—	±100	—	ppm

HT7039A-2

Ta=25°C

Symbol	Parameter	Test Conditions		Min.	Typ.	Max.	Unit
		V _{DD}	Conditions				
V _{DET}	Detection Voltage	—	—	3.861	3.900	3.939	V
V _{HYS}	Hysteresis Width	—	—	0.02 V _{DET}	0.05 V _{DET}	0.10 V _{DET}	V
I _{DD}	Operating Current	4.9V	No load	—	3	6	μA
V _{DD}	Operating Voltage	—	—	2.1	—	24	V
I _{OL}	Output Sink Current	2.5V	V _{OUT} =0.25V	1.2	2.5	—	mA
$\frac{\Delta V_{DET}}{\Delta T_a}$	Temperature Coefficient	—	-40°C<T _a <85°C	—	±100	—	ppm

HT7044A-2

Ta=25°C

Symbol	Parameter	Test Conditions		Min.	Typ.	Max.	Unit
		V _{DD}	Conditions				
V _{DET}	Detection Voltage	—	—	4.356	4.400	4.444	V
V _{HYS}	Hysteresis Width	—	—	0.02 V _{DET}	0.05 V _{DET}	0.10 V _{DET}	V
I _{DD}	Operating Current	5.4V	No load	—	3	6	μA
V _{DD}	Operating Voltage	—	—	2.1	—	24	V
I _{OL}	Output Sink Current	3.6V	V _{OUT} =0.36V	3	6	—	mA
$\frac{\Delta V_{DET}}{\Delta T_a}$	Temperature Coefficient	—	-40°C<T _a <85°C	—	±100	—	ppm

HT7050A-2

Ta=25°C

Symbol	Parameter	Test Conditions		Min.	Typ.	Max.	Unit
		V _{DD}	Conditions				
V _{DET}	Detection Voltage	—	—	4.950	5.000	5.050	V
V _{HYS}	Hysteresis Width	—	—	0.02 V _{DET}	0.05 V _{DET}	0.10 V _{DET}	V
I _{DD}	Operating Current	6.0V	No load	—	3	6	μA
V _{DD}	Operating Voltage	—	—	2.1	—	24	V
I _{OL}	Output Sink Current	3.6V	V _{OUT} =0.36V	3	6	—	mA
$\frac{\Delta V_{DET}}{\Delta T_a}$	Temperature Coefficient	—	-40°C<T _a <85°C	—	±100	—	ppm

HT7082A-2

Ta=25°C

Symbol	Parameter	Test Conditions		Min.	Typ.	Max.	Unit
		V _{DD}	Conditions				
V _{DET}	Detection Voltage	—	—	8.118	8.200	8.282	V
V _{HYS}	Hysteresis Width	—	—	0.02 V _{DET}	0.05 V _{DET}	0.10 V _{DET}	V
I _{DD}	Operating Current	9.2V	No load	—	3	6	μA
V _{DD}	Operating Voltage	—	—	2.1	—	24	V
I _{OL}	Output Sink Current	3.6V	V _{OUT} =0.36V	3	6	—	mA
$\frac{\Delta V_{DET}}{\Delta T_a}$	Temperature Coefficient	—	-40°C<T _a <85°C	—	±100	—	ppm

Functional Description

The HT70xxA-2 series is a set of voltage detectors equipped with a high stability voltage reference which is connected to the negative input of a comparator—denoted as V_{REF} in the following figure for NMOS output voltage detector.

When the voltage drop to the positive input of the comparator (i.e., V_B) is higher than V_{REF} , V_{OUT} goes high, M1 turns off, and V_B is expressed as $V_{BH} = V_{DD} \times (R_B + R_C) / (R_A + R_B + R_C)$. If V_{DD} is decreased so that V_B falls to a value less than V_{REF} , the comparator output inverts from high to low, V_{OUT} goes low, V_C is high, M1 turns on, R_C is bypassed, and V_B becomes: $V_{BL} = V_{DD} \times R_B / (R_A + R_B)$, which is less than V_{BH} . By so doing, the comparator output will stay low to prevent the circuit from oscillating when $V_B \approx V_{REF}$.

If V_{DD} falls below the minimum operating voltage, the output becomes undefined. When V_{DD} goes from low to $V_{DD} \times R_B / (R_A + R_B) > V_{REF}$, the comparator output and V_{OUT} goes high.

The detectable voltage is defined as:

$$V_{DET} (-) = \frac{R_A + R_B + R_C}{R_B + R_C} \times V_{REF}$$

The release voltage is defined as:

$$V_{DET} (+) = \frac{R_A + R_B}{R_B} \times V_{REF}$$

The hysteresis width is:

$$V_{HYS} = V_{DET} (+) - V_{DET} (-)$$

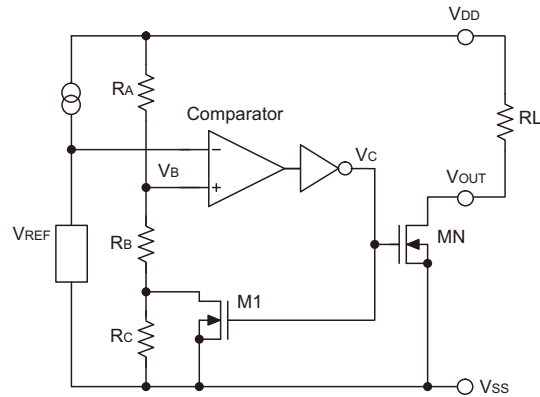

NMOS Output Voltage Detector

The figure demonstrates the NMOS output type with positive output polarity (V_{OUT} is normally open, active low). The HT70xxA-2 series also supplies options for other output types with active high outputs. Application circuits shown are examples of positive output polarity (normally open, active low) unless otherwise specified.

Application Circuits

Microcomputer Reset Circuit

Normally a reset circuit is required to protect the microcomputer system from malfunctions due to power line interruptions. The following examples show how different output configurations perform a reset function in various systems.

- NMOS open drain output application for separate power supply

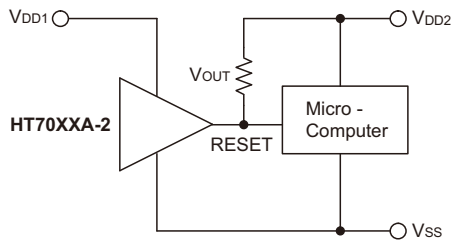

- NMOS open drain output application with R-C delay

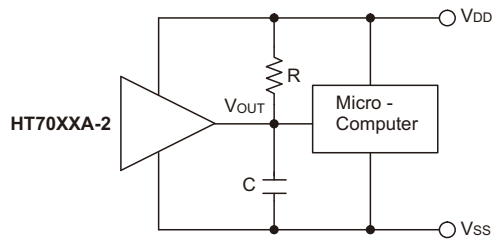

Power-on Reset Circuit

With several external components, the NMOS open drain type of the HT70xxA-2 series can be used to perform a power-on reset function as shown:

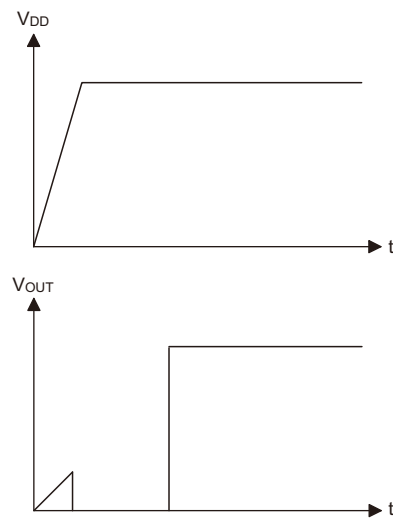
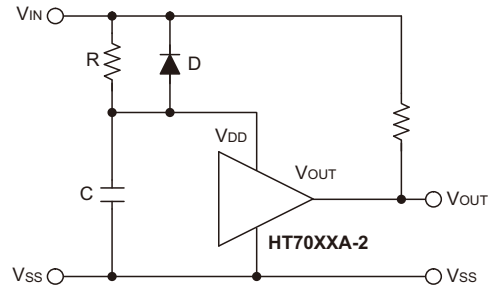

5V Power Line Monitoring Circuit

Generally, a minimum operating voltage of 4.5V is guaranteed in a 5V power line system. The HT7044A-2 is recommended for use as 5V power line monitoring circuit.

- 5V power line monitor with power-on reset

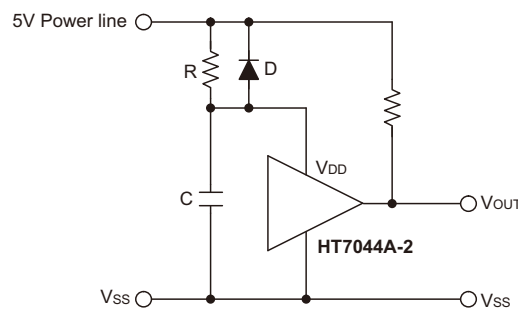

- with 5V voltage regulator

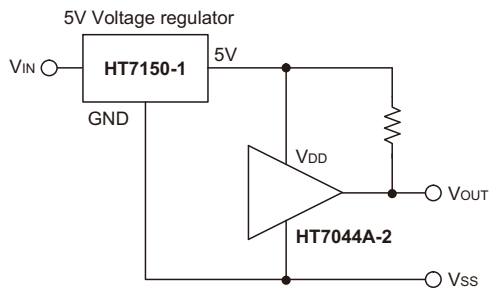

Malfunction Analysis

The following circuit demonstrates the way a circuit analyzes malfunctions by monitoring the variation or spike noise of power supply voltage.

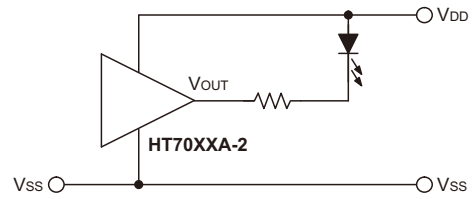

Change of Detectable Voltage

If the required voltage is not found in the standard product selection table, it is possible to change it by using external resistance dividers or diodes.

- Varying the detectable voltage with a resistance divider

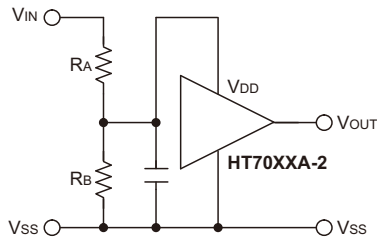

$$\text{Detectable voltage} = \frac{R_A + R_B}{R_B} \times V_{DET}$$

$$\text{Hysteresis width} = \frac{R_A + R_B}{R_B} \times V_{HYS}$$

- Varying the detectable voltage with a diode

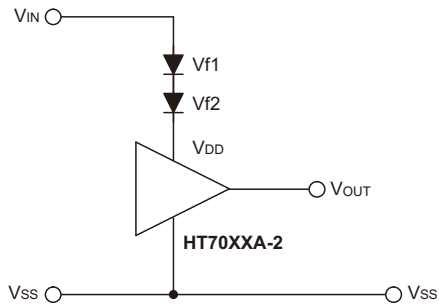

$$\text{Detectable Voltage} = V_{f1} + V_{f2} + V_{DET}$$

Charge Monitoring Circuit

The following circuit shows a charged monitor for protection against battery deterioration by overcharging. When the voltage of the battery is higher than the set detectable voltage, the transistor turns on to bypass the charge current, protecting the battery from overcharging.

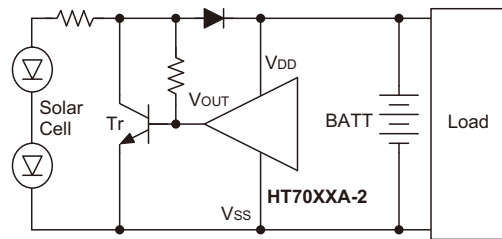

Level Selector

The following diagram illustrates a logic level selector.

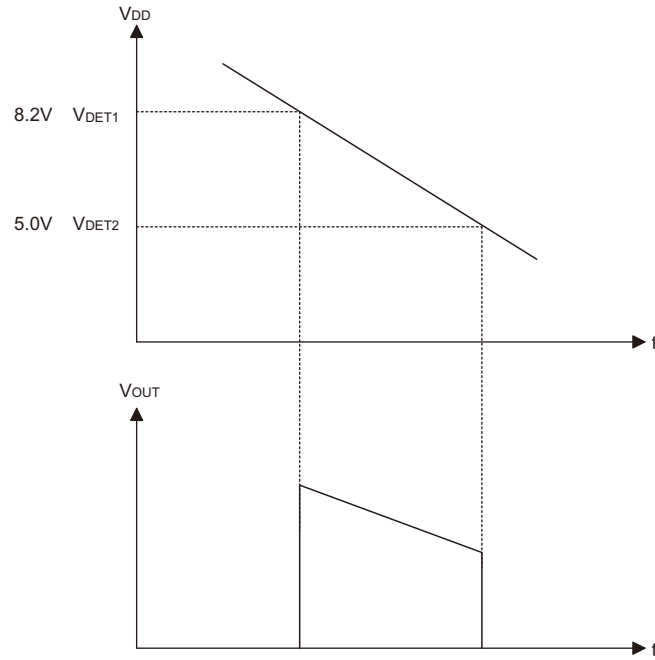
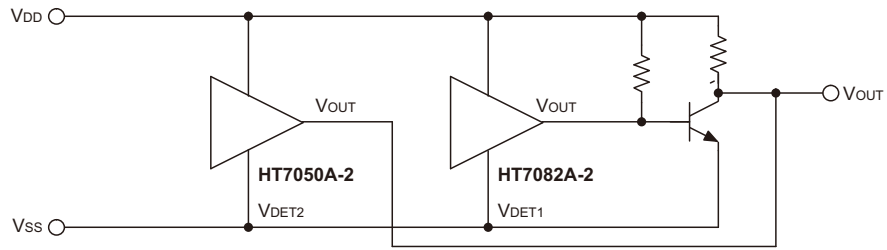

Package Information

Note that the package information provided here is for consultation purposes only. As this information may be updated at regular intervals users are reminded to consult the Holtek website (<http://www.holtek.com.tw/english/literature/package.pdf>) for the latest version of the package information.

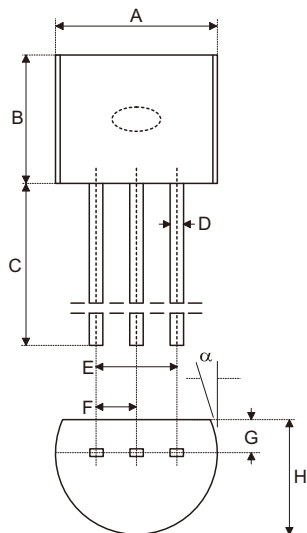
3-pin TO92 Outline Dimensions

Symbol	Dimensions in inch		
	Min.	Nom.	Max.
A	0.170	—	0.200
B	0.170	—	0.200
C	0.500	—	—
D	0.011	—	0.020
E	0.090	—	0.110
F	0.045	—	0.055
G	0.045	—	0.065
H	0.130	—	0.160
α	0°	—	10°

Symbol	Dimensions in mm		
	Min.	Nom.	Max.
A	4.32	—	5.08
B	4.32	—	5.08
C	12.70	—	—
D	0.28	—	0.51
E	2.29	—	2.79
F	1.14	—	1.40
G	1.14	—	1.65
H	3.30	—	4.06
α	0°	—	10°

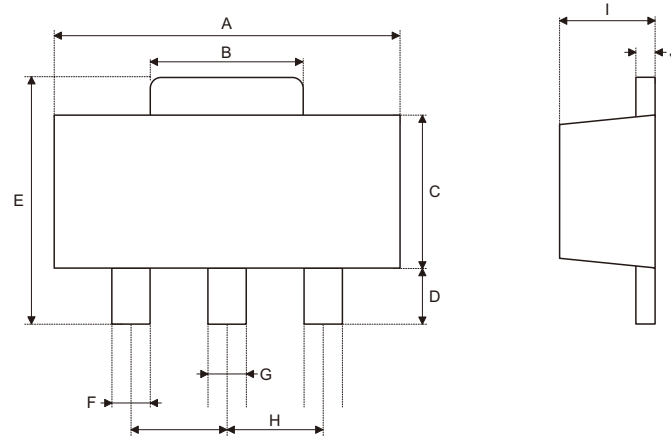
3-pin SOT89 Outline Dimensions

Symbol	Dimensions in inch		
	Min.	Nom.	Max.
A	0.173	—	0.181
B	0.059	—	0.072
C	0.090	—	0.102
D	0.035	—	0.047
E	0.155	—	0.167
F	0.014	—	0.019
G	0.017	—	0.022
H	—	0.059	—
I	55	—	63
J	14	—	17

Symbol	Dimensions in mm		
	Min.	Nom.	Max.
A	4.39	—	4.60
B	1.50	—	1.83
C	2.29	—	2.59
D	0.89	—	1.19
E	3.94	—	4.24
F	0.36	—	0.48
G	0.43	—	0.56
H	—	1.50	—
I	1.40	—	1.60
J	0.36	—	0.43

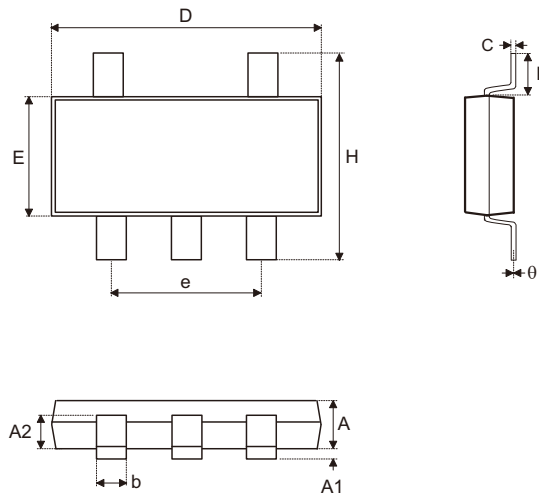
5-pin SOT23-5 Outline Dimensions

Symbol	Dimensions in inch		
	Min.	Nom.	Max.
A	0.039	—	0.051
A1	—	—	0.004
A2	0.028	—	0.035
b	0.014	—	0.020
C	0.004	—	0.010
D	0.106	—	0.122
E	0.055	—	0.071
e	—	0.075	—
H	0.102	—	0.118
L	0.015	—	—
θ	0°	—	9°

Symbol	Dimensions in mm		
	Min.	Nom.	Max.
A	1.00	—	1.30
A1	—	—	0.10
A2	0.70	—	0.90
b	0.35	—	0.50
C	0.10	—	0.25
D	2.70	—	3.10
E	1.40	—	1.80
e	—	1.90	—
H	2.60	—	3.0
L	0.37	—	—
θ	0°	—	9°

Product Tape and Reel Specifications

TO92 Reel Dimensions (Unit: mm)

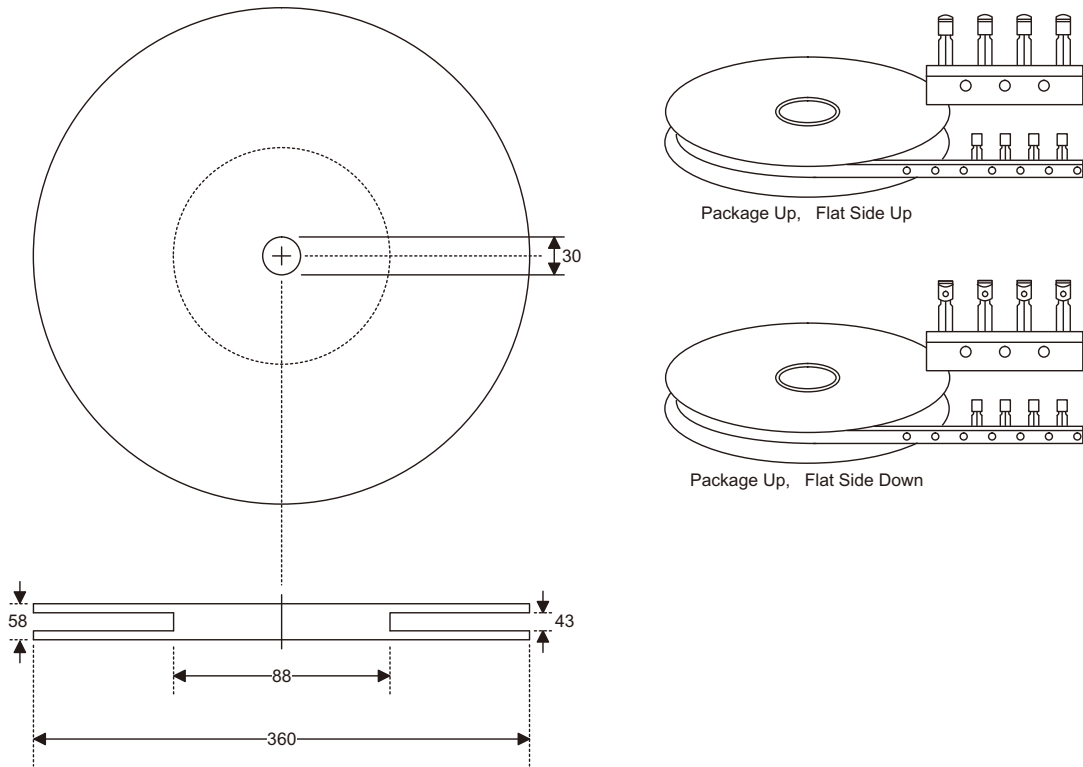

Reel Dimensions

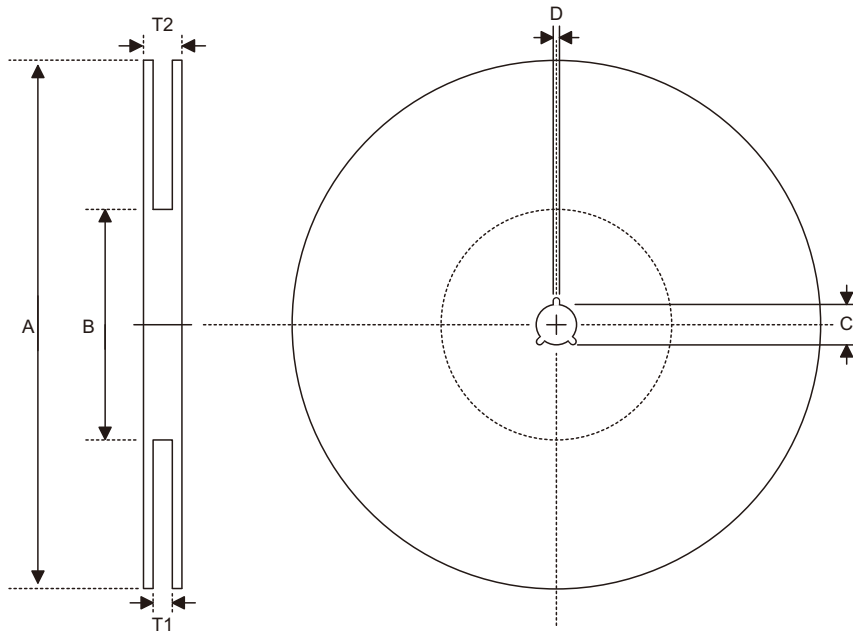

SOT89-3

Symbol	Description	Dimensions in mm
A	Reel Outer Diameter	180.0±1.0
B	Reel Inner Diameter	62.0±1.5
C	Spindle Hole Diameter	12.75 ^{+0.15/-0.00}
D	Key Slit Width	1.90±0.15
T1	Space Between Flange	12.4 ^{+0.2/-0.0}
T2	Reel Thickness	17.0 ^{+0.0/-0.4}

SOT23-5

Symbol	Description	Dimensions in mm
A	Reel Outer Diameter	178.0±1.0
B	Reel Inner Diameter	62.0±1.0
C	Spindle Hole Diameter	13.0±0.2
D	Key Slit Width	2.50±0.25
T1	Space Between Flange	8.4 ^{+1.5/-0.0}
T2	Reel Thickness	11.4 ^{+1.5/-0.0}

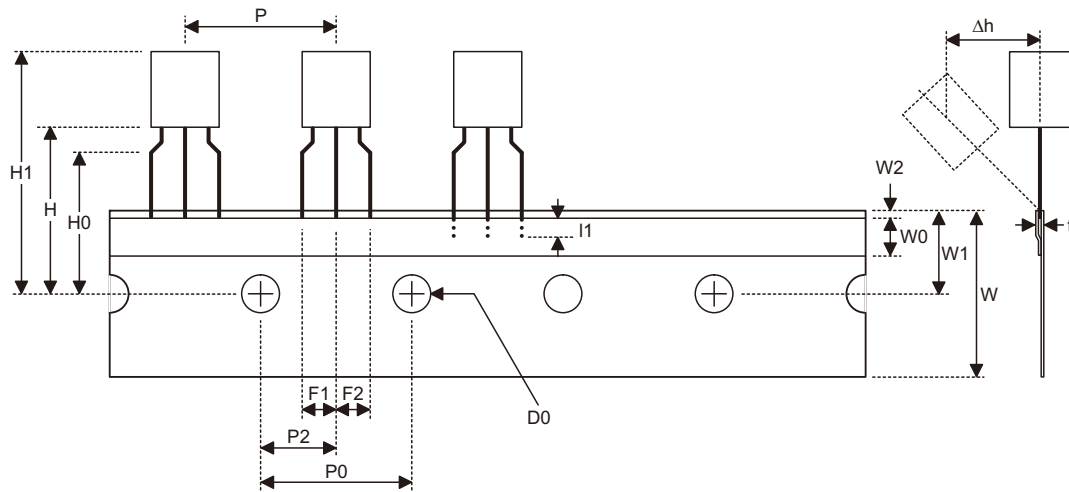
Carrier Tape Dimensions

TO92

Symbol	Description	Dimensions in mm
l1	Taped Lead Length	(2.5)
P	Component Pitch	12.7±1.0
P ₀	Perforation Pitch	12.7±0.3
P ₂	Component to Perforation (Length Direction)	6.35±0.40
F ₁	Lead Spread	2.5 ^{+0.4/-0.1}
F ₂	Lead Spread	2.5 ^{+0.4/-0.1}
Δh	Component Alignment	0.0±0.1
W	Carrier Tape Width	18.0 ^{+1.0/-0.5}
W ₀	Hold-down Tape Width	6.0±0.5
W ₁	Perforation Position	9.0±0.5
W ₂	Hold-down Tape Position	(0.5)
H ₀	Lead Clinch Height	16.0±0.5
H ₁	Component Height	Less than 24.7
D ₀	Perforation Diameter	4.0±0.2
t	Taped Lead Thickness	0.7±0.2
H	Component Base Height	19.0±0.5

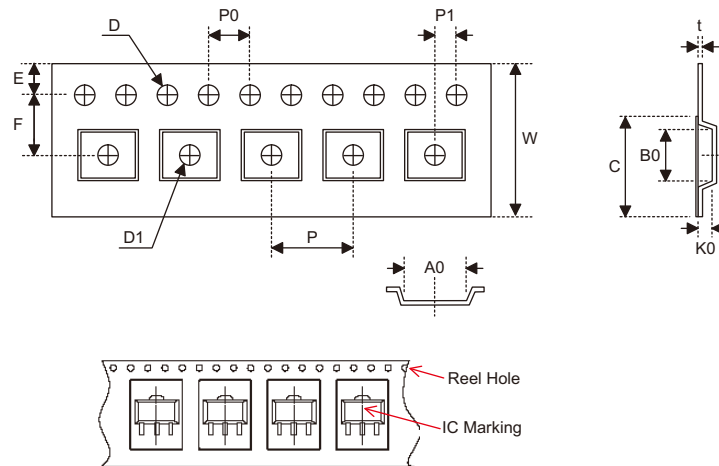
Note: Thickness less than 0.38±0.05mm~0.5mm
P0 Accumulated pitch tolerance: ±1mm/20pitches.
() Bracketed figures are for consultation only

Carrier Tape Dimensions

SOT89-3

Symbol	Description	Dimensions in mm
W	Carrier Tape Width	12.0 ^{+0.3/-0.1}
P	Cavity Pitch	8.0±0.1
E	Perforation Position	1.75±0.10
F	Cavity to Perforation (Width Direction)	5.50±0.05
D	Perforation Diameter	1.5 ^{+0.1/-0.0}
D1	Cavity Hole Diameter	1.5 ^{+0.1/-0.0}
P0	Perforation Pitch	4.0±0.1
P1	Cavity to Perforation (Length Direction)	2.0±0.1
A0	Cavity Length	4.8±0.1
B0	Cavity Width	4.5±0.1
K0	Cavity Depth	1.8±0.1
t	Carrier Tape Thickness	0.300±0.013
C	Cover Tape Width	9.3±0.1

SOT23-5

Symbol	Description	Dimensions in mm
W	Carrier Tape Width	8.0±0.3
P	Cavity Pitch	4.0±0.1
E	Perforation Position	1.75±0.10
F	Cavity to Perforation (Width Direction)	3.50±0.05
D	Perforation Diameter	1.5 ^{+0.1/-0.0}
D1	Cavity Hole Diameter	1.5 ^{+0.1/-0.0}
P0	Perforation Pitch	4.0±0.1
P1	Cavity to Perforation (Length Direction)	2.00±0.05
A0	Cavity Length	3.15±0.10
B0	Cavity Width	3.2±0.1
K0	Cavity Depth	1.4±0.1
t	Carrier Tape Thickness	0.20±0.03
C	Cover Tape Width	5.3±0.1

Holtek Semiconductor Inc. (Headquarters)

No.3, Creation Rd. II, Science Park, Hsinchu, Taiwan
Tel: 886-3-563-1999
Fax: 886-3-563-1189
<http://www.holtek.com.tw>

Holtek Semiconductor Inc. (Taipei Sales Office)

4F-2, No. 3-2, YuanQu St., Nankang Software Park, Taipei 115, Taiwan
Tel: 886-2-2655-7070
Fax: 886-2-2655-7373
Fax: 886-2-2655-7383 (International sales hotline)

Holtek Semiconductor (China) Inc.

Building No. 10, Xinzhu Court, (No. 1 Headquarters), 4 Cuizhu Road, Songshan Lake, Dongguan, China 523808
Tel: 86-769-2626-1300
Fax: 86-769-2626-1311

Holtek Semiconductor (USA), Inc. (North America Sales Office)

46729 Fremont Blvd., Fremont, CA 94538, USA
Tel: 1-510-252-9880
Fax: 1-510-252-9885
<http://www.holtek.com>

Copyright © 2012 by HOLTEK SEMICONDUCTOR INC.

The information appearing in this Data Sheet is believed to be accurate at the time of publication. However, Holtek assumes no responsibility arising from the use of the specifications described. The applications mentioned herein are used solely for the purpose of illustration and Holtek makes no warranty or representation that such applications will be suitable without further modification, nor recommends the use of its products for application that may present a risk to human life due to malfunction or otherwise. Holtek's products are not authorized for use as critical components in life support devices or systems. Holtek reserves the right to alter its products without prior notification. For the most up-to-date information, please visit our web site at <http://www.holtek.com.tw>.