

### Features

- Output voltage ranges: Fixed range of 1.8V, 2.5V, 2.7V, 3.0V, 3.3V, 5.0V type.
- Highly accuracy:  $\pm 2\%$
- Low voltage drop: 360mV (typ.),  $V_{OUT}=5.0V$  at 500mA
- Guaranteed output current: 500mA
- Low quiescent current: 4 $\mu$ A (typ.)
- Current limiting
- Over-temperature shutdown
- SOT223, SOT23-5, SOT89, TO92 Packages

### Applications

- Battery powered systems
- Personal Digital Assistants
- Peripheral cards
- PCMCIA cards
- Personal Communication Equipment

### General Description

The HT78XX series of positive, linear regulators features low quiescent current (4 $\mu$ A typ.) with low dropout voltage, making them ideal for battery applications. The devices are capable of supplying 500mA of output current continuously.

They are available with several fixed output voltages ranging from 1.8V to 5.0V. Although designed primarily

as fixed voltage regulators, these devices can be used with external components to obtain variable voltages and currents.

These rugged devices have Thermal Shutdown and Current Limiting to prevent device failure under the "Worst" of operating conditions.

### Selection Table

Part No.	Output Voltage	Tolerance	Package	Marking
HT7818	1.8V	$\pm 2\%$	SOT223 SOT23-5 SOT89 TO92	HT78XX (for SOT223) 78XX# (for SOT23-5) HT78XX# (for SOT89) HT78XX (for TO92)
HT7825	2.5V			
HT7827	2.7V			
HT7830	3.0V			
HT7833	3.3V			
HT7850	5.0V			

Note: "XX" stands for output voltages.

For lead free devices, TO92 & SOT223 package will add a "#" mark at the end of the date code, whereas SOT89 & SOT23-5 packages will add a "#" mark at the end of the marking.

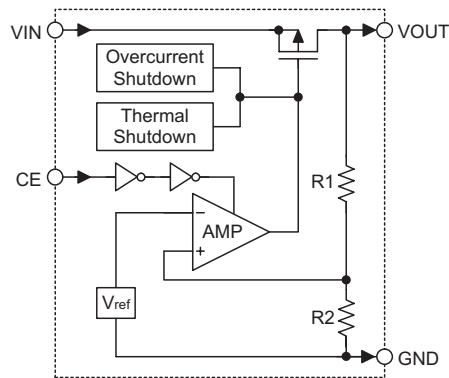
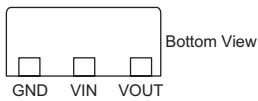
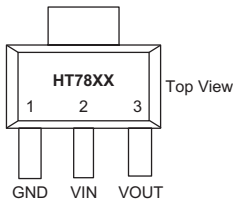
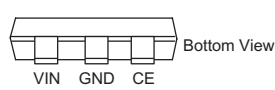
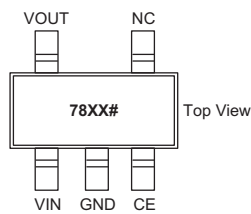
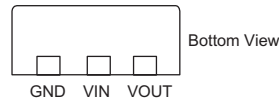
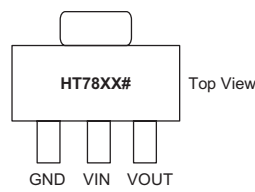
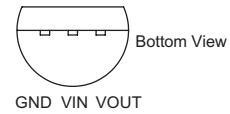
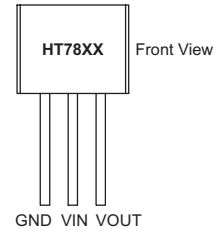
**Block Diagram**

**Pin Assignment**
**SOT223**

**SOT23-5**

**SOT89**

**TO92**

**Pin Description**

Pin No.				Pin Name	Description
SOT223	SOT23-5	SOT89	TO92		
—	3	—	—	CE	Chip enable pin, high enable
3	5	3	3	VOUT	Output pin
2	1	2	2	VIN	Input pin
1	2	1	1	GND	Ground pin
—	4	—	—	NC	No connection

**Absolute Maximum Ratings\***

Maximum Supply Voltage ..... up to 8.5V      Storage Temperature ..... -50°C to 125°C  
 Operating Temperature ..... -40°C to 85°C

Note: These are stress ratings only. Stresses exceeding the range specified under "Absolute Maximum Ratings" may cause substantial damage to the device. Functional operation of this device at other conditions beyond those listed in the specification is not implied and prolonged exposure to extreme conditions may affect device reliability.

\*\*\* Absolute maximum ratings indicate limits beyond which damage to the device may occur. Operating Ratings indicate conditions for which the device is intended to be functional, but do not guarantee specific performance limits. The guaranteed specifications apply only for the test conditions listed.

**Thermal Information**

Symbol	Parameter	Package	Max.	Unit
$\theta_{JA}$	Thermal Resistance (Junction to Ambient) (Assume no ambient airflow, no heat sink)	SOT223	134	$^{\circ}\text{C/W}$
		SOT23-5	500	$^{\circ}\text{C/W}$
		SOT89	200	$^{\circ}\text{C/W}$
		TO92	200	$^{\circ}\text{C/W}$
$P_D$	Power Dissipation	SOT223	0.75	W
		SOT23-5	0.20	W
		SOT89	0.50	W
		TO92	0.50	W

Note:  $P_D$  is measured at  $T_a = 25^{\circ}\text{C}$

**Electrical Characteristics**

$T_J = 25^{\circ}\text{C}$ ,  $V_{IN} = V_{OUT} + 1.0\text{V}$ ,  $I_O = 1\text{mA}$ , unless otherwise specified

Symbol	Parameter	Test Conditions	Min.	Typ.	Max.	Unit	
$V_{IN}$	Input Voltage	—	—	—	8	V	
$\Delta V_{OUT}$	Output Voltage Tolerance	—	-2	—	2	%	
$I_{SS}$	Quiescent Current	$I_O = 0\text{mA}$ , $V_{CE} = V_{IN}$	—	4	7	$\mu\text{A}$	
$\Delta V_{LOAD}$	Load Regulation (Note1)	$1\text{mA} \leq I_{OUT} \leq 500\text{mA}$	—	0.004	0.008	%/mA	
$V_{DROP}$	Dropout Voltage (Note2)	$\Delta V_{OUT} = 2\%$ $I_{OUT} = 500\text{mA}$	$V_O \leq 1.8\text{V}$	—	800	1200	mV
			$2.5\text{V} \leq V_O \leq 2.7\text{V}$	—	500	650	
			$3.0\text{V} \leq V_O \leq 5.0\text{V}$	—	360	500	
$\Delta V_{LINE}$	Line Regulation	$V_{OUT} + 1.0\text{V} \leq V_{IN} \leq 8.0\text{V}$	—	0.2	0.3	%/V	
$I_{LIM}$	Current Limit (Note3)	$\Delta V_{OUT} = 10\%$	500	—	—	mA	
$V_{IH}$	CE Input High Threshold	$V_{OUT} + 1\text{V} \leq V_{IN} \leq 8\text{V}$	2.0	—	—	V	
$V_{IL}$	CE Input Low Threshold	$V_{OUT} + 1\text{V} \leq V_{IN} \leq 8\text{V}$	—	—	0.8	V	
$I_{SD}$	Shutdown Current	CE input voltage $\leq 0.8\text{V}$	—	0.5	1	$\mu\text{A}$	
$\frac{\Delta V_{OUT}}{\Delta T_a}$	Temperature Coefficient	$-40^{\circ}\text{C} < T_a < 85^{\circ}\text{C}$	—	$\pm 0.8$	—	mV/ $^{\circ}\text{C}$	

- Note:
1. Load regulation is measured at a constant junction temperature, using pulse testing with a low ON time and is guaranteed up to the maximum power dissipation. Power dissipation is determined by the input/output differential voltage and the output current. Guaranteed maximum power dissipation will not be available over the full input/output range. The maximum allowable power dissipation at any ambient temperature is  $P_D = (T_{J(MAX)} - T_a) / \theta_{JA}$ .
  2. Dropout voltage is defined as the input voltage minus the output voltage that produces a 2% change in the output voltage from the value at  $V_{IN} = V_{OUT} + 1\text{V}$  with a fixed load.
  3. Current limit is measured by pulsing for a short time.

Application Circuits

Basic Circuits

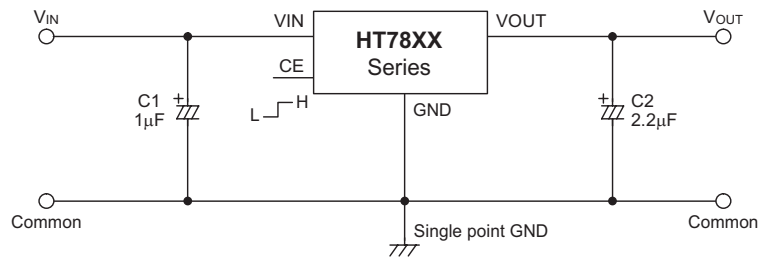
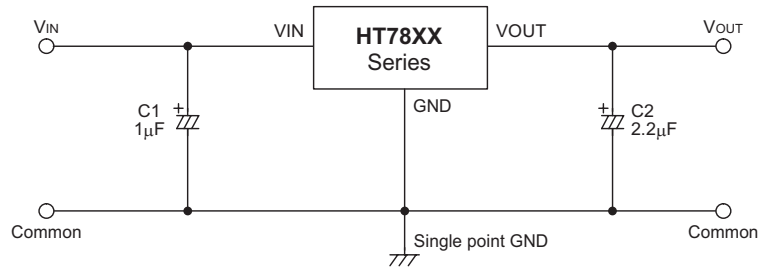

Typical Application Circuits

- High output current positive voltage regulator

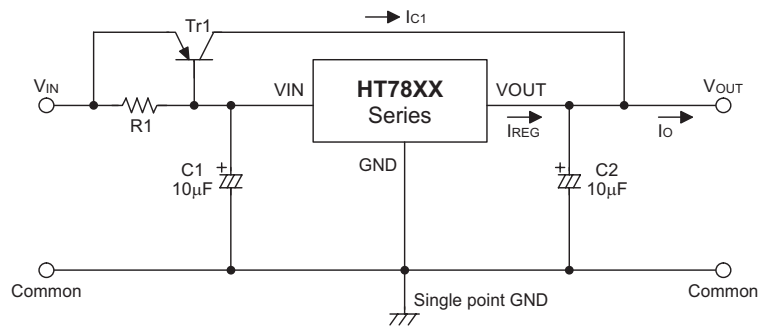

$$R_1 = \frac{V_{BE1}}{I_{REG} - \frac{I_{c1}}{(1+\beta)}} ,$$

$$I_o = I_{c1} + I_{REG}$$

• Increased Output voltage Circuit

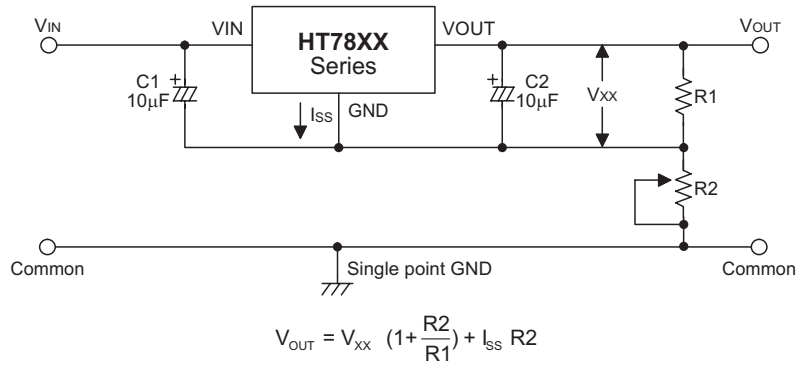

• Dual Supply Circuit

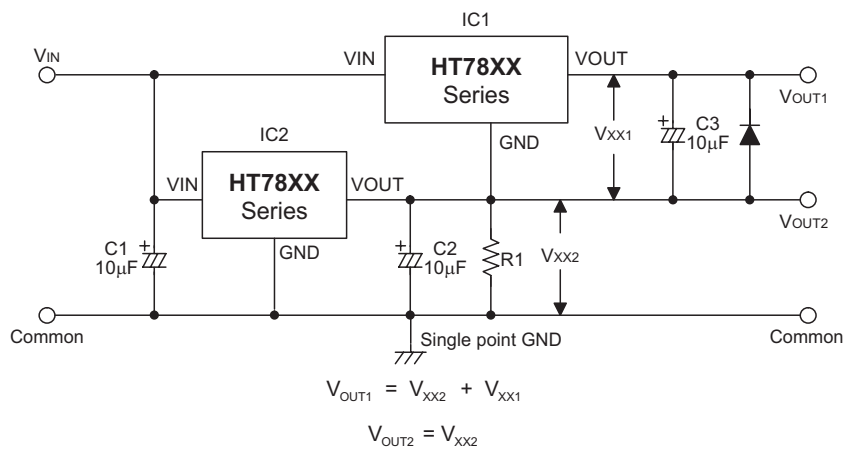

• Tracking Voltage Regulator

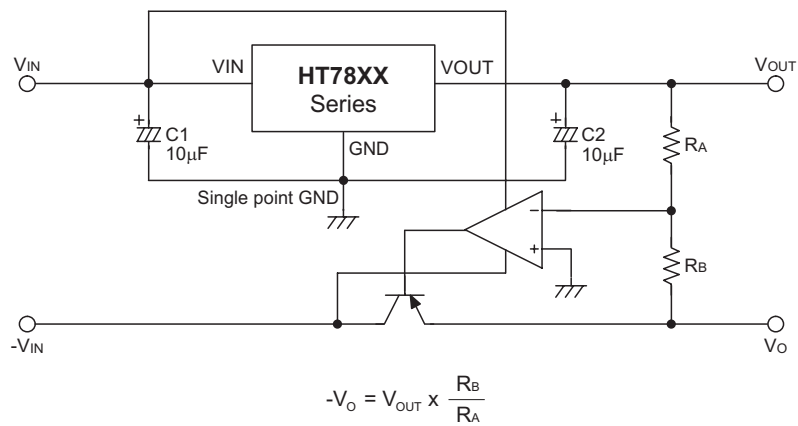

**Package Information**

**3-pin SOT223 Outline Dimensions**

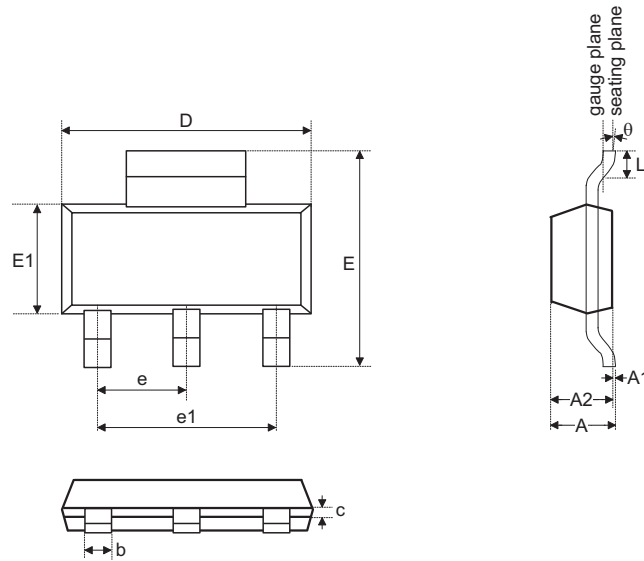

Symbol	Dimensions in mm		
	Min.	Nom.	Max.
A	—	—	1.8
A1	0.02	—	0.10
A2	1.5	—	1.7
b	0.66	—	0.84
C	0.23	—	0.35
D	6.3	—	6.7
E	6.7	—	7.3
E1	3.3	—	3.7
e	—	2.3	—
e1	—	4.6	—
L	0.75	—	—
theta	0°	—	10°

**5-pin SOT23-5 Outline Dimensions**

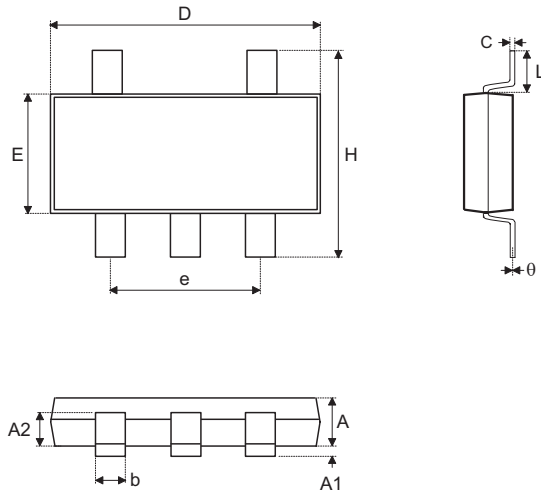

Symbol	Dimensions in mm		
	Min.	Nom.	Max.
A	1	—	1.3
A1	—	—	0.1
A2	0.7	—	0.9
b	0.35	—	0.50
C	0.10	—	0.25
D	2.7	—	3.1
E	1.4	—	1.8
e	—	1.9	—
H	2.6	—	3.0
L	0.37	—	—
$\theta$	1°	—	9°

**3-pin SOT89 Outline Dimensions**

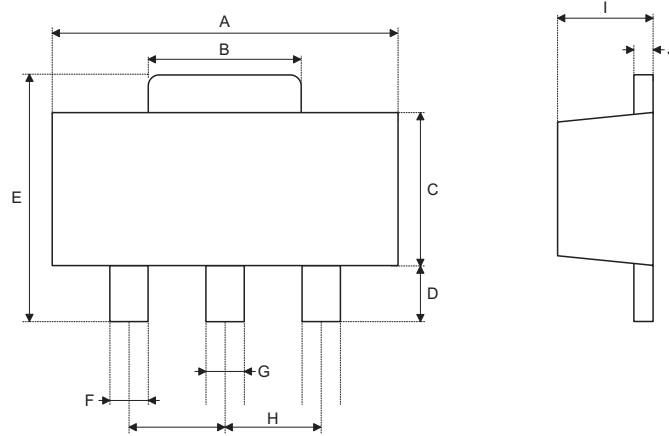

Symbol	Dimensions in mil		
	Min.	Nom.	Max.
A	173	—	181
B	59	—	72
C	90	—	102
D	35	—	47
E	155	—	167
F	14	—	19
G	17	—	22
H	—	59	—
I	55	—	63
J	14	—	17

**3-pin TO92 Outline Dimensions**

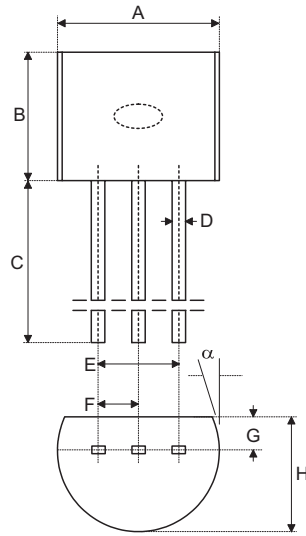

Symbol	Dimensions in mil		
	Min.	Nom.	Max.
A	170	—	200
B	170	—	200
C	500	—	—
D	11	—	20
E	90	—	110
F	45	—	55
G	45	—	65
H	130	—	160
I	8	—	18
$\alpha$	4°	—	6°

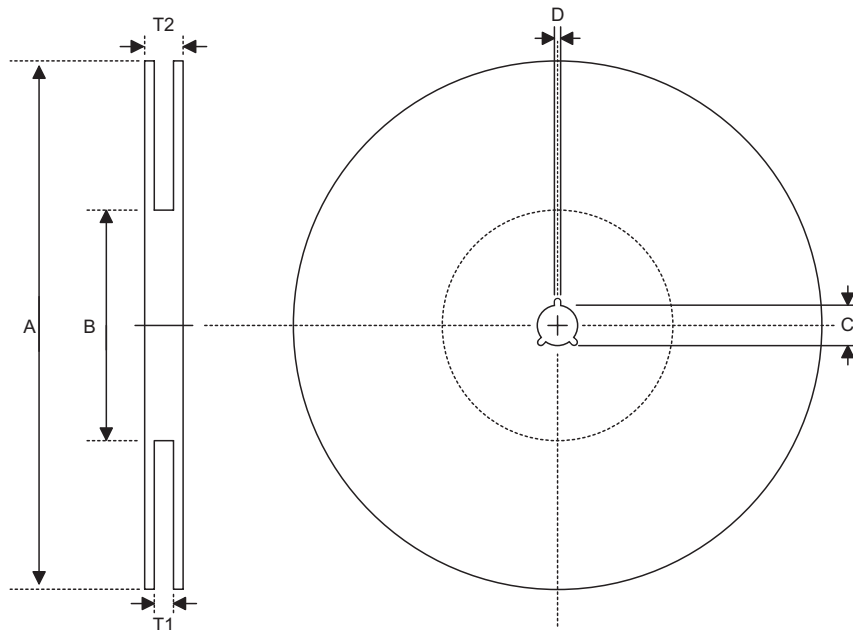
**Product Tape and Reel Specifications**
**Reel Dimensions**

**SOT223**

Symbol	Description	Dimensions in mm
A	Reel Outer Diameter	330.0±1.0
B	Reel Inner Diameter	62.0±1.5
C	Spindle Hole Diameter	12.75±0.15
D	Key Slit Width	2.0 <sup>+0.6/-0.0</sup>
T1	Space Between Flange	12.4 <sup>+0.2/-0.0</sup>
T2	Reel Thickness	16.4 <sup>+0.0/-0.4</sup>

**SOT23-5**

Symbol	Description	Dimensions in mm
A	Reel Outer Diameter	178.0±1.0
B	Reel Inner Diameter	62.0±1.0
C	Spindle Hole Diameter	13.0±0.2
D	Key Slit Width	2.50±0.25
T1	Space Between Flange	8.4 <sup>+1.5/-0.0</sup>
T2	Reel Thickness	11.4 <sup>+1.5/-0.0</sup>

**SOT89**

Symbol	Description	Dimensions in mm
A	Reel Outer Diameter	180.0±1.0
B	Reel Inner Diameter	62.0±1.5
C	Spindle Hole Diameter	12.75 <sup>+0.15/-0.00</sup>
D	Key Slit Width	1.90±0.15
T1	Space Between Flange	12.4 <sup>+0.2/-0.0</sup>
T2	Reel Thickness	17.0 <sup>+0.0/-0.4</sup>

3-pin TO92 Reel Dimensions (Unit: mm)

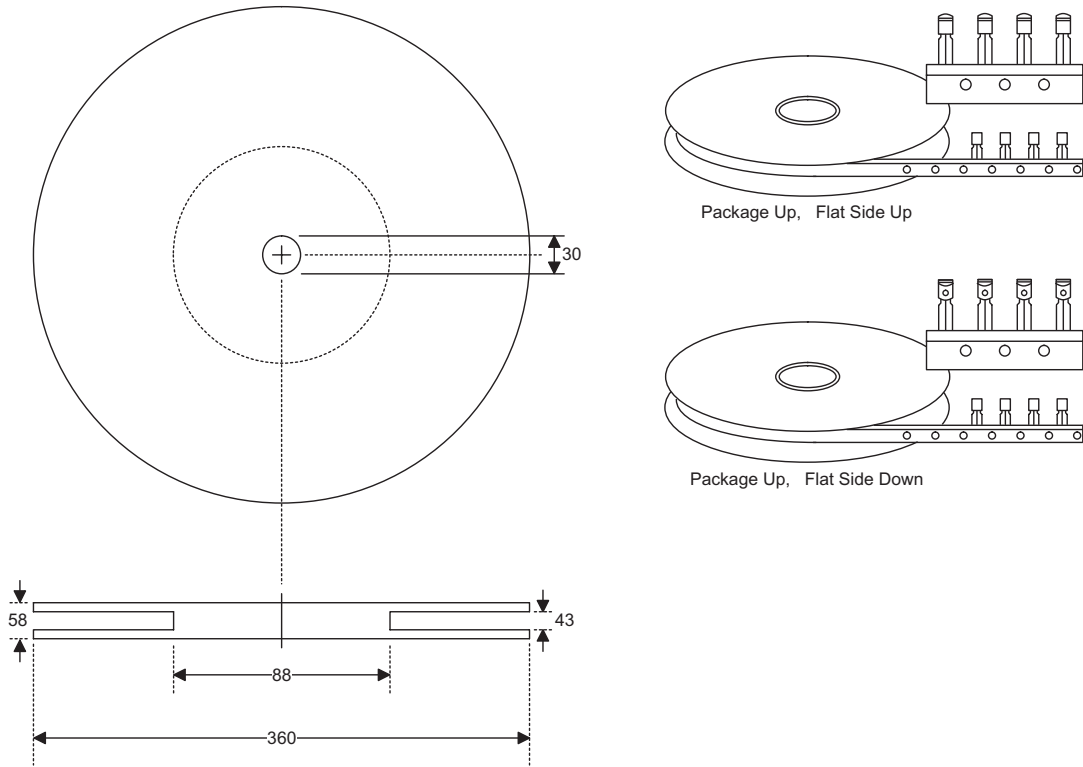

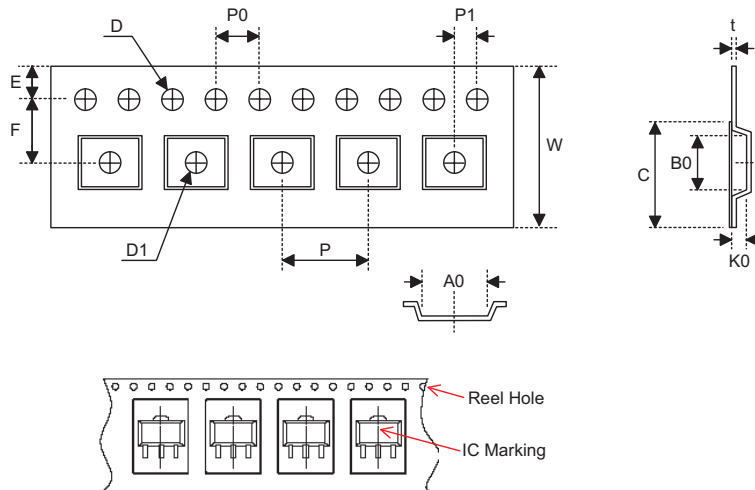
**Carrier Tape Dimensions**

**SOT223**

Symbol	Description	Dimensions in mm
W	Carrier Tape Width	12.0±0.3
P	Cavity Pitch	8.0±0.1
E	Perforation Position	1.75±0.10
F	Cavity to Perforation (Width Direction)	5.50±0.05
D	Perforation Diameter	1.5 <sup>+0.1/-0.0</sup>
D1	Cavity Hole Diameter	1.5 <sup>+0.1/-0.0</sup>
P0	Perforation Pitch	4.0±0.1
P1	Cavity to Perforation (Length Direction)	2.00±0.05
A0	Cavity Length	6.9±0.1
B0	Cavity Width	7.5±0.1
K0	Cavity Depth	2.1±0.1
t	Carrier Tape Thickness	0.30±0.05
C	Cover Tape Width	9.3±0.1

**SOT23-5**

Symbol	Description	Dimensions in mm
W	Carrier Tape Width	8.0±0.3
P	Cavity Pitch	4.0±0.1
E	Perforation Position	1.75±0.10
F	Cavity to Perforation (Width Direction)	3.50±0.05
D	Perforation Diameter	1.5 <sup>+0.1/-0.0</sup>
D1	Cavity Hole Diameter	1.5 <sup>+0.1/-0.0</sup>
P0	Perforation Pitch	4.0±0.1
P1	Cavity to Perforation (Length Direction)	2.00±0.05
A0	Cavity Length	3.15±0.1
B0	Cavity Width	3.2±0.1
K0	Cavity Depth	1.4±0.1
t	Carrier Tape Thickness	0.20±0.03
C	Cover Tape Width	5.3±0.1

SOT89

Symbol	Description	Dimensions in mm
W	Carrier Tape Width	12.0 <sup>+0.3/-0.1</sup>
P	Cavity Pitch	8.0±0.1
E	Perforation Position	1.75±0.10
F	Cavity to Perforation (Width Direction)	5.50±0.05
D	Perforation Diameter	1.5 <sup>+0.1/-0.0</sup>
D1	Cavity Hole Diameter	1.5 <sup>+0.1/-0.0</sup>
P0	Perforation Pitch	4.0±0.1
P1	Cavity to Perforation (Length Direction)	2.0±0.1
A0	Cavity Length	4.8±0.1
B0	Cavity Width	4.5±0.1
K0	Cavity Depth	1.8±0.1
t	Carrier Tape Thickness	0.300±0.013
C	Cover Tape Width	9.3±0.1

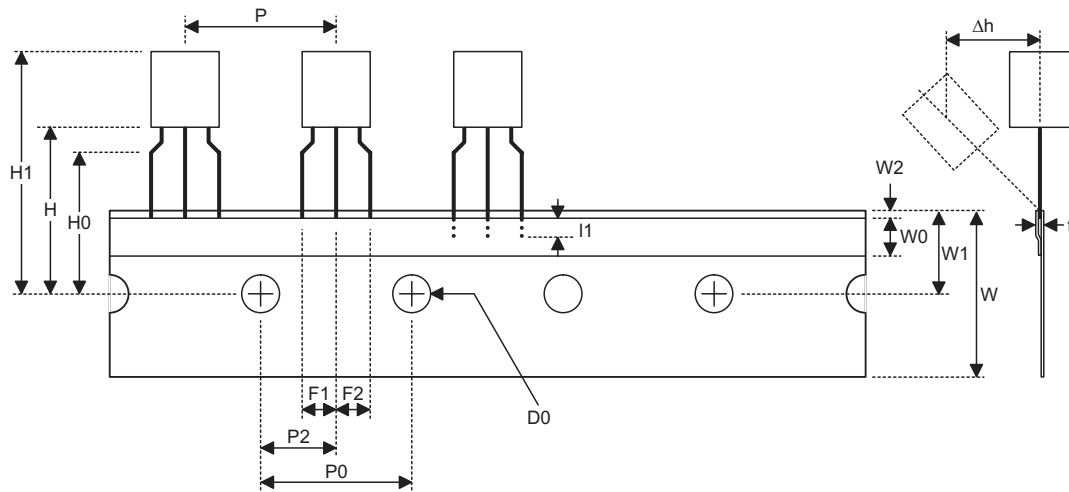
**Carrier Tape Dimensions**

**TO92**

Symbol	Description	Dimensions in mm
l1	Taped Lead Length	(2.5)
P	Component Pitch	12.7±1.0
P <sub>0</sub>	Perforation Pitch	12.7±0.3
P <sub>2</sub>	Component to Perforation (Length Direction)	6.35±0.40
F <sub>1</sub>	Lead Spread	2.5 <sup>+0.4/-0.1</sup>
F <sub>2</sub>	Lead Spread	2.5 <sup>+0.4/-0.1</sup>
Δh	Component Alignment	0.0±0.1
W	Carrier Tape Width	18.0 <sup>+1.0/-0.5</sup>
W <sub>0</sub>	Hold-down Tape Width	6.0±0.5
W <sub>1</sub>	Perforation Position	9.0±0.5
W <sub>2</sub>	Hold-down Tape Position	(0.5)
H <sub>0</sub>	Lead Clinch Height	16.0±0.5
H <sub>1</sub>	Component Height	Less than 24.7
D <sub>0</sub>	Perforation Diameter	4.0±0.2
t	Taped Lead Thickness	0.7±0.2
H	Component Base Height	19.0±0.5

Note: Thickness less than 0.38±0.05mm~0.5mm  
P0 Accumulated pitch tolerance: ±1mm/20pitches.  
( ) Bracketed figures are for consultation only

Copyright © 2008 by HOLTEK SEMICONDUCTOR INC.

The information appearing in this Data Sheet is believed to be accurate at the time of publication. However, Holtek assumes no responsibility arising from the use of the specifications described. The applications mentioned herein are used solely for the purpose of illustration and Holtek makes no warranty or representation that such applications will be suitable without further modification, nor recommends the use of its products for application that may present a risk to human life due to malfunction or otherwise. Holtek's products are not authorized for use as critical components in life support devices or systems. Holtek reserves the right to alter its products without prior notification. For the most up-to-date information, please visit our web site at <http://www.holtek.com.tw>.