

Features

- Low power consumption
- Low voltage drop
- Low temperature coefficient
- High input voltage (up to 24V)
- Output voltage accuracy: tolerance $\pm 3\%$
- TO92, SOT89 and SOT23-5 package

Applications

- Battery-powered equipment
- Communication equipment
- Audio/Video equipment

General Description

The HT71xx-1 series is a set of three-terminal low power high voltage regulators implemented in CMOS technology. They allow input voltages as high as 24V. They are available with several fixed output voltages ranging from 2.1V to 5.0V. CMOS technology ensures low voltage drop and low quiescent current.

Although designed primarily as fixed voltage regulators, these devices can be used with external components to obtain variable voltages and currents.

Selection Table

Part No.	Output Voltage	Package	Marking
HT7121-1	2.1V	TO92 SOT89 SOT23-5	71xx-1 (for TO92, 2.1V~2.7V) 71xxA-1 (for TO92, 3.0V~5.0V) 71xx-1 (for SOT89) 71xx-1# (for SOT89) 71xx-1+ (for SOT89) 1xx1 (for SOT23-5) 1xx1# (for SOT23-5) 1xx1+ (for SOT23-5)
HT7123-1	2.3V		
HT7125-1	2.5V		
HT7127-1	2.7V		
HT7130-1	3.0V		
HT7133-1	3.3V		
HT7136-1	3.6V		
HT7144-1	4.4V		
HT7150-1	5.0V		

Note: "xx" stands for output voltages.

Both lead free and green compound devices are available. Note the symbol marks below:

"#" stands for lead free devices.

Blank and "+" stands for green compound devices, which are Lead-free and Halogen-free.

For the TO92 package, the symbol mark will be at the end of the date code. Whereas for the SOT89 and SOT23-5, the symbol mark will be located at the end of IC marking.

Block Diagram

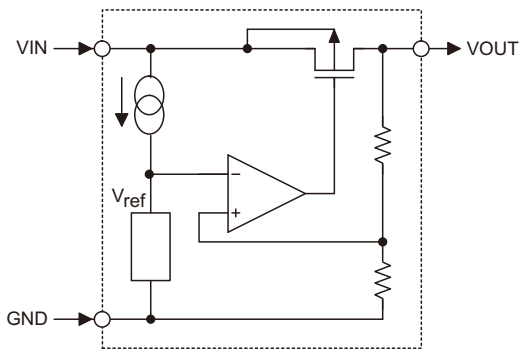

Pin Assignment

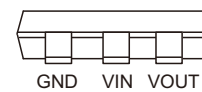
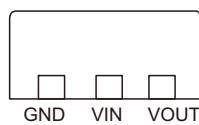
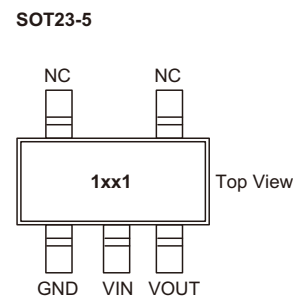
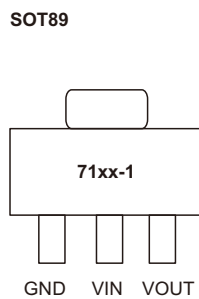
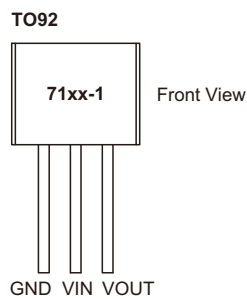

Absolute Maximum Ratings

Supply Voltage-0.3V to 26V Storage Temperature-50°C to 125°C
 Operating Temperature-40°C to 85°C

Note: These are stress ratings only. Stresses exceeding the range specified under "Absolute Maximum Ratings" may cause substantial damage to the device. Functional operation of this device at other conditions beyond those listed in the specification is not implied and prolonged exposure to extreme conditions may affect device reliability.

Thermal Information

Symbol	Parameter	Package	Max.	Unit
θ_{JA}	Thermal Resistance (Junction to Ambient) (Assume no ambient airflow, no heat sink)	SOT23-5	500	°C/W
		SOT89	200	°C/W
		TO92	200	°C/W
P_D	Power Dissipation	SOT23-5	0.20	W
		SOT89	0.50	W
		TO92	0.50	W

Note: P_D is measured at $T_a = 25^\circ\text{C}$

Electrical Characteristics
HT7121-1, +2.1V Output Type

Ta=25°C

Symbol	Parameter	Test Conditions		Min.	Typ.	Max.	Unit
		V _{IN}	Conditions				
V _{OUT}	Output Voltage	4.1V	I _{OUT} =10mA	2.037	2.100	2.163	V
I _{OUT}	Output Current	4.1V	—	20	30	—	mA
ΔV _{OUT}	Load Regulation	4.1V	1mA ≤ I _{OUT} ≤ 20mA	—	60	100	mV
V _{DIF}	Voltage Drop (Note)	—	I _{OUT} =1mA, ΔV _{OUT} =2%	—	100	—	mV
I _{SS}	Current Consumption	4.1V	No load	—	2.5	4.0	μA
$\frac{\Delta V_{OUT}}{\Delta V_{IN} \times V_{OUT}}$	Line Regulation	—	3.1V ≤ V _{IN} ≤ 24V I _{OUT} =1mA	—	0.2	—	%/V
V _{IN}	Input Voltage	—	—	—	—	24	V
$\frac{\Delta V_{OUT}}{\Delta T_a}$	Temperature Coefficient	4.1V	I _{OUT} =10mA -40°C < Ta < 85°C	—	±0.37	—	mV/°C

Note: Dropout voltage is defined as the input voltage minus the output voltage that produces a 2% change in the output voltage from the value at V_{IN} = V_{OUT}+2V with a fixed load.

HT7123-1, +2.3V Output Type

Ta=25°C

Symbol	Parameter	Test Conditions		Min.	Typ.	Max.	Unit
		V _{IN}	Conditions				
V _{OUT}	Output Voltage	4.3V	I _{OUT} =10mA	2.231	2.300	2.369	V
I _{OUT}	Output Current	4.3V	—	20	30	—	mA
ΔV _{OUT}	Load Regulation	4.3V	1mA ≤ I _{OUT} ≤ 20mA	—	60	100	mV
V _{DIF}	Voltage Drop (Note)	—	I _{OUT} =1mA, ΔV _{OUT} =2%	—	100	—	mV
I _{SS}	Current Consumption	4.3V	No load	—	2.5	4.0	μA
$\frac{\Delta V_{OUT}}{\Delta V_{IN} \times V_{OUT}}$	Line Regulation	—	3.3V ≤ V _{IN} ≤ 24V I _{OUT} =1mA	—	0.2	—	%/V
V _{IN}	Input Voltage	—	—	—	—	24	V
$\frac{\Delta V_{OUT}}{\Delta T_a}$	Temperature Coefficient	4.3V	I _{OUT} =10mA -40°C < Ta < 85°C	—	±0.39	—	mV/°C

Note: Dropout voltage is defined as the input voltage minus the output voltage that produces a 2% change in the output voltage from the value at V_{IN} = V_{OUT}+2V with a fixed load.

HT7125-1, +2.5V Output Type

Ta=25°C

Symbol	Parameter	Test Conditions		Min.	Typ.	Max.	Unit
		V _{IN}	Conditions				
V _{OUT}	Output Voltage	4.5V	I _{OUT} =10mA	2.425	2.500	2.575	V
I _{OUT}	Output Current	4.5V	—	20	30	—	mA
ΔV _{OUT}	Load Regulation	4.5V	1mA ≤ I _{OUT} ≤ 20mA	—	60	100	mV
V _{DIF}	Voltage Drop (Note)	—	I _{OUT} =1mA, ΔV _{OUT} =2%	—	100	—	mV
I _{SS}	Current Consumption	4.5V	No load	—	2.5	4.0	μA
$\frac{\Delta V_{OUT}}{\Delta V_{IN} \times V_{OUT}}$	Line Regulation	—	3.5V ≤ V _{IN} ≤ 24V I _{OUT} =1mA	—	0.2	—	%/V
V _{IN}	Input Voltage	—	—	—	—	24	V
$\frac{\Delta V_{OUT}}{\Delta T_a}$	Temperature Coefficient	4.5V	I _{OUT} =10mA -40°C < T _a < 85°C	—	±0.41	—	mV/°C

Note: Dropout voltage is defined as the input voltage minus the output voltage that produces a 2% change in the output voltage from the value at V_{IN} = V_{OUT}+2V with a fixed load.

HT7127-1, +2.7V Output Type

Ta=25°C

Symbol	Parameter	Test Conditions		Min.	Typ.	Max.	Unit
		V _{IN}	Conditions				
V _{OUT}	Output Voltage	4.7V	I _{OUT} =10mA	2.619	2.700	2.781	V
I _{OUT}	Output Current	4.7V	—	20	30	—	mA
ΔV _{OUT}	Load Regulation	4.7V	1mA ≤ I _{OUT} ≤ 20mA	—	60	100	mV
V _{DIF}	Voltage Drop (Note)	—	I _{OUT} =1mA, ΔV _{OUT} =2%	—	100	—	mV
I _{SS}	Current Consumption	4.7V	No load	—	2.5	4.0	μA
$\frac{\Delta V_{OUT}}{\Delta V_{IN} \times V_{OUT}}$	Line Regulation	—	3.7V ≤ V _{IN} ≤ 24V I _{OUT} =1mA	—	0.2	—	%/V
V _{IN}	Input Voltage	—	—	—	—	24	V
$\frac{\Delta V_{OUT}}{\Delta T_a}$	Temperature Coefficient	4.7V	I _{OUT} =10mA -40°C < T _a < 85°C	—	±0.43	—	mV/°C

Note: Dropout voltage is defined as the input voltage minus the output voltage that produces a 2% change in the output voltage from the value at V_{IN} = V_{OUT}+2V with a fixed load.

HT7130-1, +3.0V Output Type

Ta=25°C

Symbol	Parameter	Test Conditions		Min.	Typ.	Max.	Unit
		V _{IN}	Conditions				
V _{OUT}	Output Voltage	5V	I _{OUT} =10mA	2.91	3.00	3.09	V
I _{OUT}	Output Current	5V	—	20	30	—	mA
ΔV _{OUT}	Load Regulation	5V	1mA ≤ I _{OUT} ≤ 20mA	—	60	100	mV
V _{DIF}	Voltage Drop (Note)	—	I _{OUT} =1mA, ΔV _{OUT} =2%	—	100	—	mV
I _{SS}	Current Consumption	5V	No load	—	2.5	4.0	μA
$\frac{\Delta V_{OUT}}{\Delta V_{IN} \times V_{OUT}}$	Line Regulation	—	4V ≤ V _{IN} ≤ 24V I _{OUT} =1mA	—	0.2	—	%/V
V _{IN}	Input Voltage	—	—	—	—	24	V
$\frac{\Delta V_{OUT}}{\Delta T_a}$	Temperature Coefficient	5V	I _{OUT} =10mA -40°C < T _a < 85°C	—	±0.45	—	mV/°C

Note: Dropout voltage is defined as the input voltage minus the output voltage that produces a 2% change in the output voltage from the value at V_{IN} = V_{OUT}+2V with a fixed load.

HT7133-1, +3.3V Output Type

Ta=25°C

Symbol	Parameter	Test Conditions		Min.	Typ.	Max.	Unit
		V _{IN}	Conditions				
V _{OUT}	Output Voltage	5.5V	I _{OUT} =10mA	3.201	3.300	3.399	V
I _{OUT}	Output Current	5.5V	—	20	30	—	mA
ΔV _{OUT}	Load Regulation	5.5V	1mA ≤ I _{OUT} ≤ 30mA	—	60	100	mV
V _{DIF}	Voltage Drop (Note)	—	I _{OUT} =1mA, ΔV _{OUT} =2%	—	100	—	mV
I _{SS}	Current Consumption	5.5V	No load	—	2.5	4.0	μA
$\frac{\Delta V_{OUT}}{\Delta V_{IN} \times V_{OUT}}$	Line Regulation	—	4.5V ≤ V _{IN} ≤ 24V I _{OUT} =1mA	—	0.2	—	%/V
V _{IN}	Input Voltage	—	—	—	—	24	V
$\frac{\Delta V_{OUT}}{\Delta T_a}$	Temperature Coefficient	5.5V	I _{OUT} =10mA -40°C < T _a < 85°C	—	±0.5	—	mV/°C

Note: Dropout voltage is defined as the input voltage minus the output voltage that produces a 2% change in the output voltage from the value at V_{IN} = V_{OUT}+2V with a fixed load.

HT7136-1, +3.6V Output Type

Ta=25°C

Symbol	Parameter	Test Conditions		Min.	Typ.	Max.	Unit
		V _{IN}	Conditions				
V _{OUT}	Output Voltage	5.6V	I _{OUT} =10mA	3.492	3.600	3.708	V
I _{OUT}	Output Current	5.6V	—	20	30	—	mA
ΔV _{OUT}	Load Regulation	5.6V	1mA ≤ I _{OUT} ≤ 30mA	—	60	100	mV
V _{DIF}	Voltage Drop (Note)	—	I _{OUT} =1mA, ΔV _{OUT} =2%	—	60	—	mV
I _{SS}	Current Consumption	5.6V	No load	—	2.5	4.0	μA
$\frac{\Delta V_{OUT}}{\Delta V_{IN} \times V_{OUT}}$	Line Regulation	—	4.6V ≤ V _{IN} ≤ 24V I _{OUT} =1mA	—	0.2	—	%/V
V _{IN}	Input Voltage	—	—	—	—	24	V
$\frac{\Delta V_{OUT}}{\Delta T_a}$	Temperature Coefficient	5.6V	I _{OUT} =10mA -40°C < T _a < 85°C	—	±0.6	—	mV/°C

Note: Dropout voltage is defined as the input voltage minus the output voltage that produces a 2% change in the output voltage from the value at V_{IN} = V_{OUT}+2V with a fixed load.

HT7144-1, +4.4V Output Type

Ta=25°C

Symbol	Parameter	Test Conditions		Min.	Typ.	Max.	Unit
		V _{IN}	Conditions				
V _{OUT}	Output Voltage	6.4V	I _{OUT} =10mA	4.268	4.400	4.532	V
I _{OUT}	Output Current	6.4V	—	20	30	—	mA
ΔV _{OUT}	Load Regulation	6.4V	1mA ≤ I _{OUT} ≤ 30mA	—	60	100	mV
V _{DIF}	Voltage Drop (Note)	—	I _{OUT} =1mA, ΔV _{OUT} =2%	—	100	—	mV
I _{SS}	Current Consumption	6.4V	No load	—	2.5	4.0	μA
$\frac{\Delta V_{OUT}}{\Delta V_{IN} \times V_{OUT}}$	Line Regulation	—	5.4V ≤ V _{IN} ≤ 24V I _{OUT} =1mA	—	0.2	—	%/V
V _{IN}	Input Voltage	—	—	—	—	24	V
$\frac{\Delta V_{OUT}}{\Delta T_a}$	Temperature Coefficient	6.4V	I _{OUT} =10mA -40°C < T _a < 85°C	—	±0.7	—	mV/°C

Note: Dropout voltage is defined as the input voltage minus the output voltage that produces a 2% change in the output voltage from the value at V_{IN} = V_{OUT}+2V with a fixed load.

HT7150-1, +5.0V Output Type

Ta=25°C

Symbol	Parameter	Test Conditions		Min.	Typ.	Max.	Unit
		V _{IN}	Conditions				
V _{OUT}	Output Voltage	7V	I _{OUT} =10mA	4.85	5.00	5.15	V
I _{OUT}	Output Current	7V	—	20	30	—	mA
ΔV _{OUT}	Load Regulation	7V	1mA ≤ I _{OUT} ≤ 30mA	—	60	100	mV
V _{DIF}	Voltage Drop (Note)	—	I _{OUT} =1mA, ΔV _{OUT} =2%	—	100	—	mV
I _{SS}	Current Consumption	7V	No load	—	2.5	4.0	μA
$\frac{\Delta V_{OUT}}{\Delta V_{IN} \times V_{OUT}}$	Line Regulation	—	6V ≤ V _{IN} ≤ 24V I _{OUT} =1mA	—	0.2	—	%/V
V _{IN}	Input Voltage	—	—	—	—	24	V
$\frac{\Delta V_{OUT}}{\Delta T_a}$	Temperature Coefficient	7V	I _{OUT} =10mA -40°C < Ta < 85°C	—	±0.75	—	mV/°C

Note: Dropout voltage is defined as the input voltage minus the output voltage that produces a 2% change in the output voltage from the value at V_{IN} = V_{OUT}+2V with a fixed load.

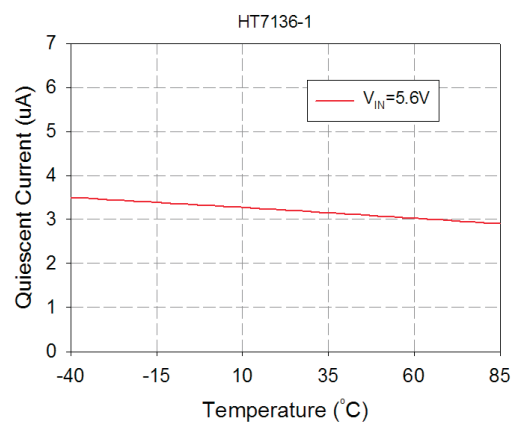
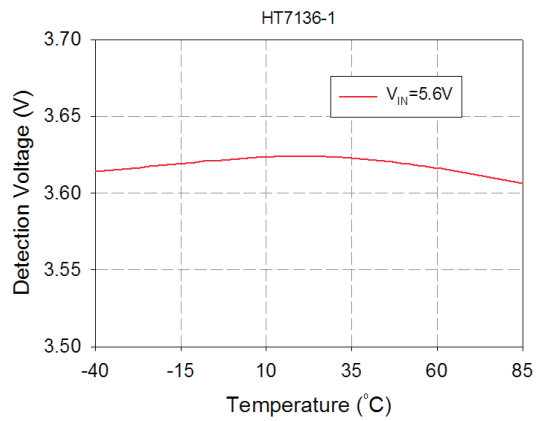
Typical Performance Characteristics

Application Circuits

Basic Circuits

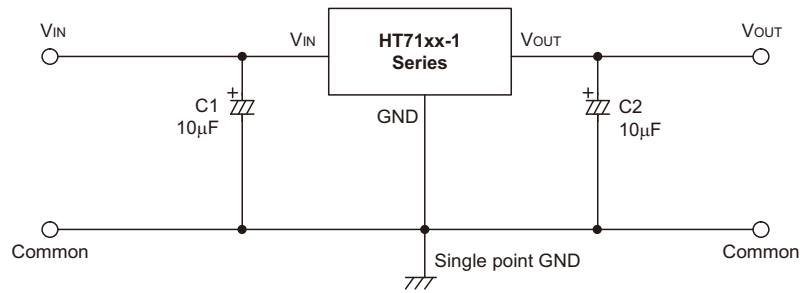

High Output Current Positive Voltage Regulator

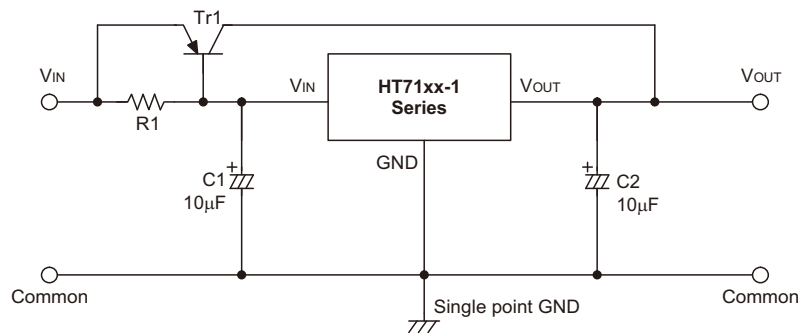

Short-Circuit Protection by Tr1

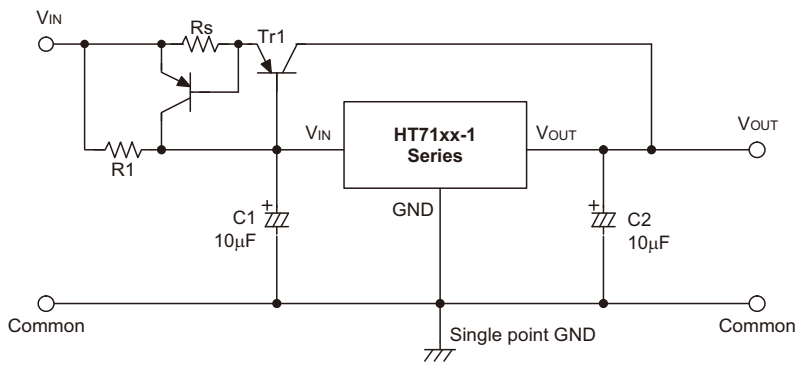

Circuit for Increasing Output Voltage

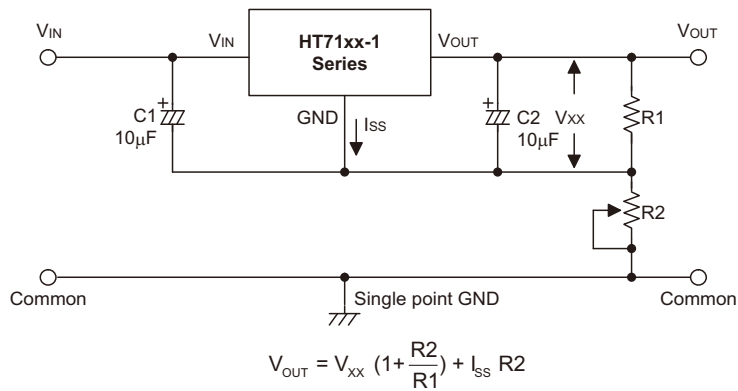

Circuit for Increasing Output Voltage

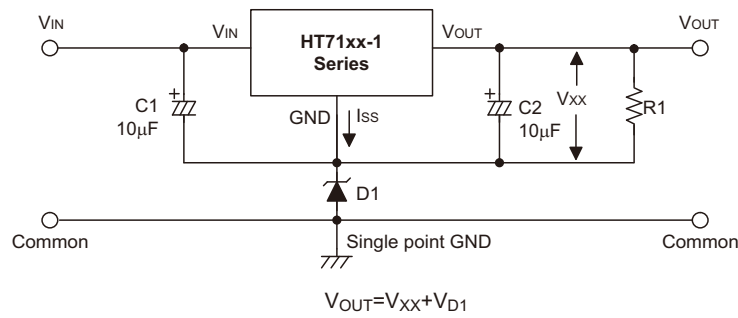

Constant Current Regulator

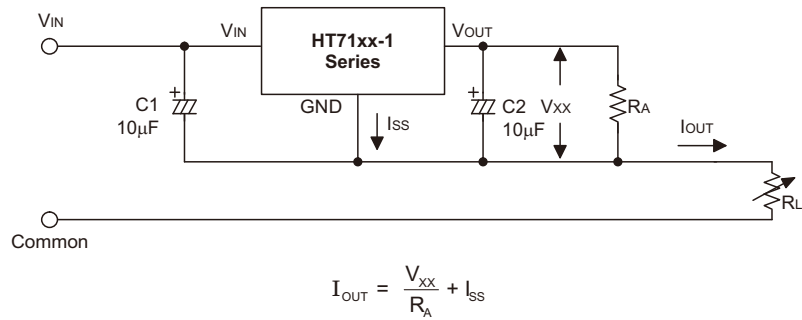

Dual Supply

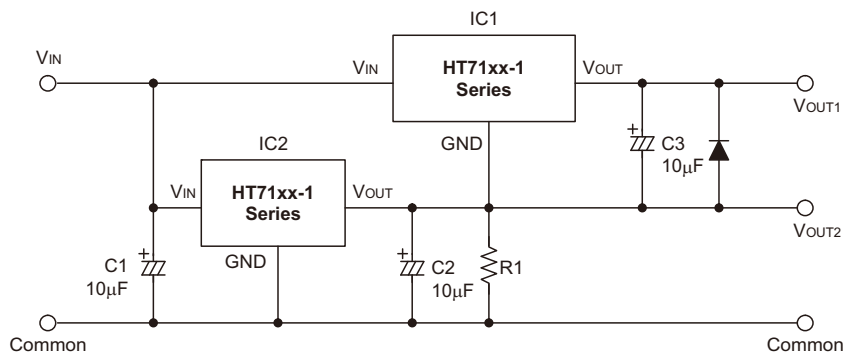

Package Information

Note that the package information provided here is for consultation purposes only. As this information may be updated at regular intervals users are reminded to consult the [Holtek website](#) for the latest version of the package information.

Additional supplementary information with regard to packaging is listed below. Click on the relevant section to be transferred to the relevant website page.

- [Further Package Information](#) (include Outline Dimensions, Product Tape and Reel Specifications)
- [Packing Materials Information](#)
- [Carton information](#)
- [PB FREE Products](#)
- [Green Packages Products](#)

3-pin TO92 Outline Dimensions

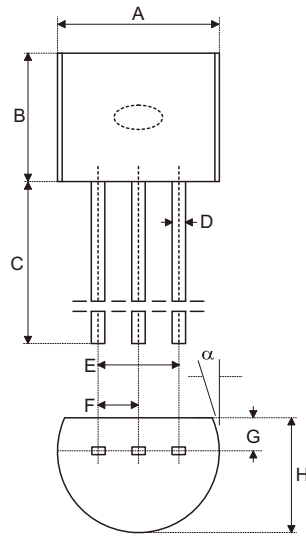

Symbol	Dimensions in inch		
	Min.	Nom.	Max.
A	0.170	—	0.200
B	0.170	—	0.200
C	0.500	—	—
D	0.011	—	0.020
E	0.090	—	0.110
F	0.045	—	0.055
G	0.045	—	0.065
H	0.130	—	0.160
α	0°	—	10°

Symbol	Dimensions in mm		
	Min.	Nom.	Max.
A	4.32	—	5.08
B	4.32	—	5.08
C	12.70	—	—
D	0.28	—	0.51
E	2.29	—	2.79
F	1.14	—	1.40
G	1.14	—	1.65
H	3.30	—	4.06
α	0°	—	10°

3-pin SOT89 Outline Dimensions

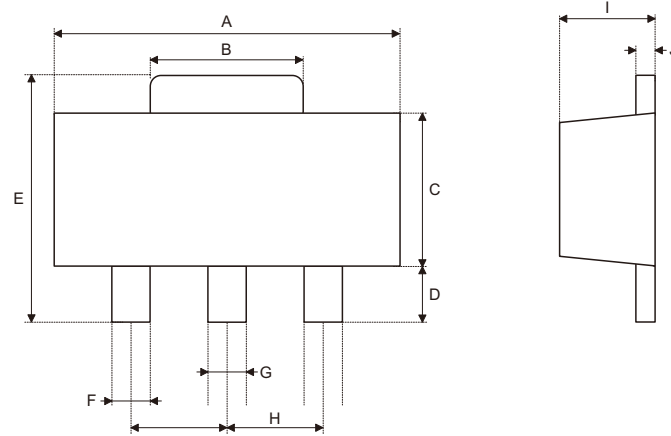

Symbol	Dimensions in inch		
	Min.	Nom.	Max.
A	0.173	—	0.181
B	0.059	—	0.072
C	0.090	—	0.102
D	0.035	—	0.047
E	0.155	—	0.167
F	0.014	—	0.019
G	0.017	—	0.022
H	—	0.059	—
I	55	—	63
J	14	—	17

Symbol	Dimensions in mm		
	Min.	Nom.	Max.
A	4.39	—	4.60
B	1.50	—	1.83
C	2.29	—	2.59
D	0.89	—	1.19
E	3.94	—	4.24
F	0.36	—	0.48
G	0.43	—	0.56
H	—	1.50	—
I	1.40	—	1.60
J	0.36	—	0.43

5-pin SOT23-5 Outline Dimensions

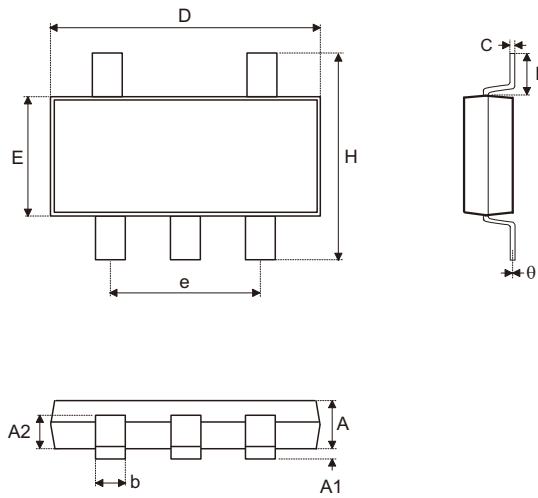

Symbol	Dimensions in inch		
	Min.	Nom.	Max.
A	0.039	—	0.051
A1	—	—	0.004
A2	0.028	—	0.035
b	0.014	—	0.020
C	0.004	—	0.010
D	0.106	—	0.122
E	0.055	—	0.071
e	—	0.075	—
H	0.102	—	0.118
L	0.015	—	—
θ	0°	—	9°

Symbol	Dimensions in mm		
	Min.	Nom.	Max.
A	1.00	—	1.30
A1	—	—	0.10
A2	0.70	—	0.90
b	0.35	—	0.50
C	0.10	—	0.25
D	2.70	—	3.10
E	1.40	—	1.80
e	—	1.90	—
H	2.60	—	3.0
L	0.37	—	—
θ	0°	—	9°

Copyright © 2013 by HOLTEK SEMICONDUCTOR INC.

The information appearing in this Data Sheet is believed to be accurate at the time of publication. However, Holtek assumes no responsibility arising from the use of the specifications described. The applications mentioned herein are used solely for the purpose of illustration and Holtek makes no warranty or representation that such applications will be suitable without further modification, nor recommends the use of its products for application that may present a risk to human life due to malfunction or otherwise. Holtek's products are not authorized for use as critical components in life support devices or systems. Holtek reserves the right to alter its products without prior notification. For the most up-to-date information, please visit our web site at <http://www.holtek.com.tw>.