

Features

- Operating voltage: 2.4V~12V
- Low power and high noise immunity CMOS technology
- Low standby current
- Capable of decoding 12 bits of information
- Binary address setting
- Received codes are checked 3 times
- Address/Data number combination
 - HT12D: 8 address bits and 4 data bits
 - HT12F: 12 address bits only
- Built-in oscillator needs only 5% resistor
- Valid transmission indicator
- Easy interface with an RF or an infrared transmission medium
- Minimal external components
- Pair with Holtek's 2¹² series of encoders
- 18-pin DIP, 20-pin SOP package

Applications

- Burglar alarm system
- Smoke and fire alarm system
- Garage door controllers
- Car door controllers
- Car alarm system
- Security system
- Cordless telephones
- Other remote control systems

General Description

The 2¹² decoders are a series of CMOS LSIs for remote control system applications. They are paired with Holtek's 2¹² series of encoders (refer to the encoder/decoder cross reference table). For proper operation, a pair of encoder/decoder with the same number of addresses and data format should be chosen.

The decoders receive serial addresses and data from a programmed 2¹² series of encoders that are transmitted by a carrier using an RF or an IR transmission medium. They compare the serial input data three times continu-

ously with their local addresses. If no error or unmatched codes are found, the input data codes are decoded and then transferred to the output pins. The VT pin also goes high to indicate a valid transmission.

The 2¹² series of decoders are capable of decoding informations that consist of N bits of address and 12–N bits of data. Of this series, the HT12D is arranged to provide 8 address bits and 4 data bits, and HT12F is used to decode 12 bits of address information.

Selection Table

| Function Part No. | Address No. | Data | | VT | Oscillator | Trigger | Package |
|----------------------|-------------|------|------|----|---------------|-----------------|--------------|
| | | No. | Type | | | | |
| HT12D | 8 | 4 | L | √ | RC oscillator | DIN active "Hi" | 18DIP, 20SOP |
| HT12F | 12 | 0 | — | √ | RC oscillator | DIN active "Hi" | 18DIP, 20SOP |

Notes: Data type: L stands for latch type data output.

VT can be used as a momentary data output.

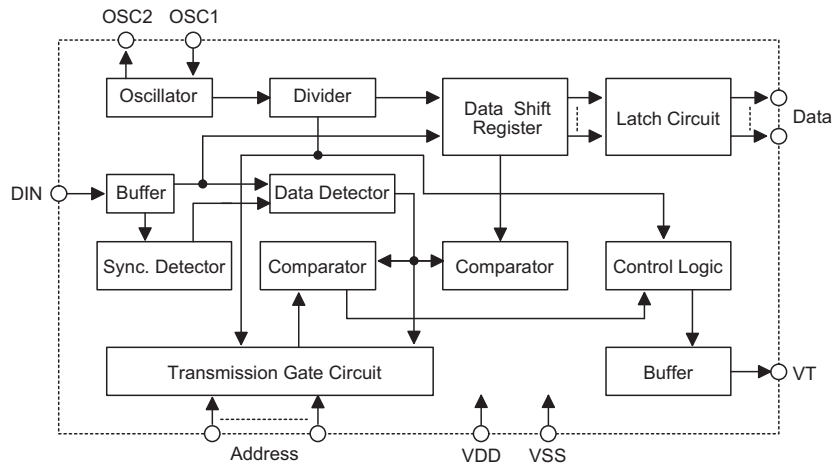
Block Diagram

Note: The address/data pins are available in various combinations (see the address/data table).

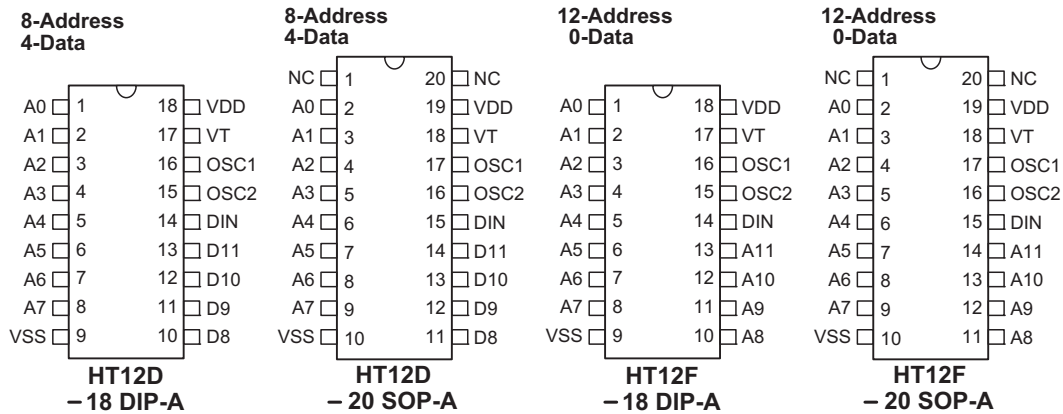
Pin Assignment

Pin Description

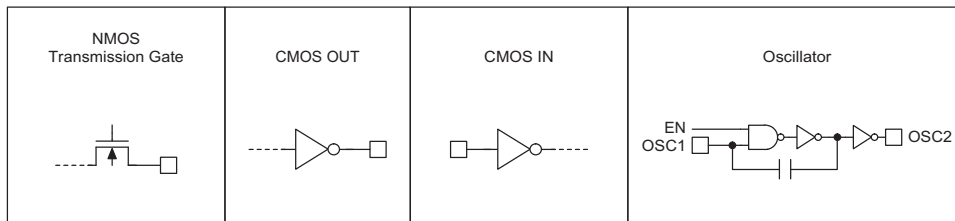
| Pin Name | I/O | Internal Connection | Description |
|----------------|-----|---------------------------|--|
| A0~A11 (HT12F) | I | NMOS Transmission Gate | Input pins for address A0~A11 setting These pins can be externally set to VSS or left open. |
| A0~A7 (HT12D) | | | Input pins for address A0~A7 setting These pins can be externally set to VSS or left open. |
| D8~D11 (HT12D) | O | CMOS OUT | Output data pins, power-on state is low. |
| DIN | I | CMOS IN | Serial data input pin |
| VT | O | CMOS OUT | Valid transmission, active high |
| OSC1 | I | Oscillator | Oscillator input pin |
| OSC2 | O | Oscillator | Oscillator output pin |
| VSS | — | — | Negative power supply, ground |
| VDD | — | — | Positive power supply |

Approximate internal connection circuits

Absolute Maximum Ratings

| | | | |
|----------------------|-------------------------------|-----------------------------|----------------|
| Supply Voltage | -0.3V to 13V | Storage Temperature | -50°C to 125°C |
| Input Voltage | $V_{SS}-0.3$ to $V_{DD}+0.3V$ | Operating Temperature | -20°C to 75°C |

Note: These are stress ratings only. Stresses exceeding the range specified under "Absolute Maximum Ratings" may cause substantial damage to the device. Functional operation of this device at other conditions beyond those listed in the specification is not implied and prolonged exposure to extreme conditions may affect device reliability.

Electrical Characteristics

Ta=25°C

| Symbol | Parameter | Test Conditions | | Min. | Typ. | Max. | Unit |
|------------------|-------------------------------------|-----------------|-----------------------------------|------|------|------|------|
| | | V _{DD} | Conditions | | | | |
| V _{DD} | Operating Voltage | — | — | 2.4 | 5 | 12 | V |
| I _{STB} | Standby Current | 5V | Oscillator stops | — | 0.1 | 1 | μA |
| | | 12V | | — | 2 | 4 | μA |
| I _{DD} | Operating Current | 5V | No load, f _{OSC} =150kHz | — | 200 | 400 | μA |
| I _O | Data Output Source Current (D8~D11) | 5V | V _{OH} =4.5V | -1 | -1.6 | — | mA |
| | Data Output Sink Current (D8~D11) | 5V | V _{OL} =0.5V | 1 | 1.6 | — | mA |
| I _{VT} | VT Output Source Current | 5V | V _{OH} =4.5V | -1 | -1.6 | — | mA |
| | VT Output Sink Current | | V _{OL} =0.5V | 1 | 1.6 | — | mA |
| V _{IH} | "H" Input Voltage | 5V | — | 3.5 | — | 5 | V |
| V _{IL} | "L" Input Voltage | 5V | — | 0 | — | 1 | V |
| f _{OSC} | Oscillator Frequency | 5V | R _{OSC} =51kΩ | — | 150 | — | kHz |

Functional Description

Operation

The 2¹² series of decoders provides various combinations of addresses and data pins in different packages so as to pair with the 2¹² series of encoders.

The decoders receive data that are transmitted by an encoder and interpret the first N bits of code period as addresses and the last 12-N bits as data, where N is the address code number. A signal on the DIN pin activates the oscillator which in turn decodes the incoming address and data. The decoders will then check the received address three times continuously. If the received address codes all match the contents of the decoder's local address, the 12-N bits of data are decoded to activate the output pins and the VT pin is set high to indicate a valid transmission. This will last unless the address code is incorrect or no signal is received.

The output of the VT pin is high only when the transmission is valid. Otherwise it is always low.

Output Type

Of the 2¹² series of decoders, the HT12F has no data output pin but its VT pin can be used as a momentary data output. The HT12D, on the other hand, provides 4 latch type data pins whose data remain unchanged until new data are received.

| Part No. | Data Pins | Address Pins | Output Type | Operating Voltage |
|----------|-----------|--------------|-------------|-------------------|
| HT12D | 4 | 8 | Latch | 2.4V~12V |
| HT12F | 0 | 12 | — | 2.4V~12V |

Flowchart

The oscillator is disabled in the standby state and activated when a logic "high" signal applies to the DIN pin. That is to say, the DIN should be kept low if there is no signal input.

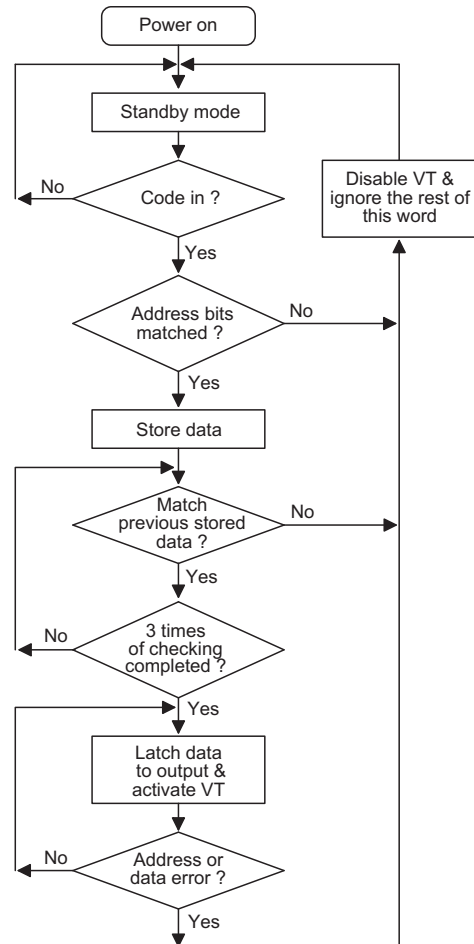

Decoder Timing

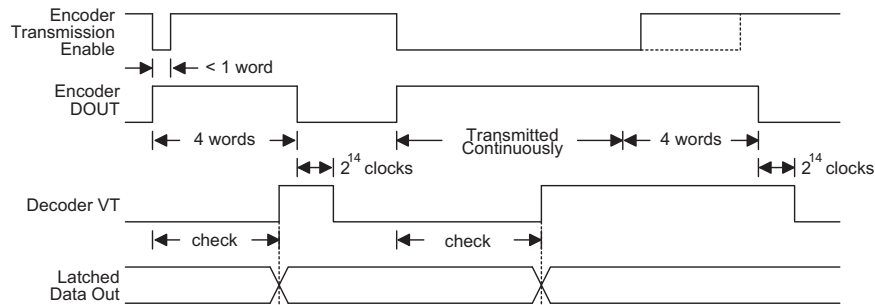

Encoder/Decoder Cross Reference Table

| Decoders Part No. | Data Pins | Address Pins | VT | Pair Encoder | Package | | | |
|-------------------|-----------|--------------|----|----------------|---------|-----|---------|-----|
| | | | | | Encoder | | Decoder | |
| | | | | | DIP | SOP | DIP | SOP |
| HT12D | 4 | 8 | √ | HT12A HT12E | 18 | 20 | 18 | 20 |
| HT12F | 0 | 12 | √ | HT12A HT12E | 18 | 20 | 18 | 20 |

Address/Data Sequence

The following table provides address/data sequence for various models of the 2¹² series of decoders.

| Part No. | Address/Data Bits | | | | | | | | | | | |
|----------|-------------------|----|----|----|----|----|----|----|----|----|-----|-----|
| | 0 | 1 | 2 | 3 | 4 | 5 | 6 | 7 | 8 | 9 | 10 | 11 |
| HT12D | A0 | A1 | A2 | A3 | A4 | A5 | A6 | A7 | D8 | D9 | D10 | D11 |
| HT12F | A0 | A1 | A2 | A3 | A4 | A5 | A6 | A7 | A8 | A9 | A10 | A11 |

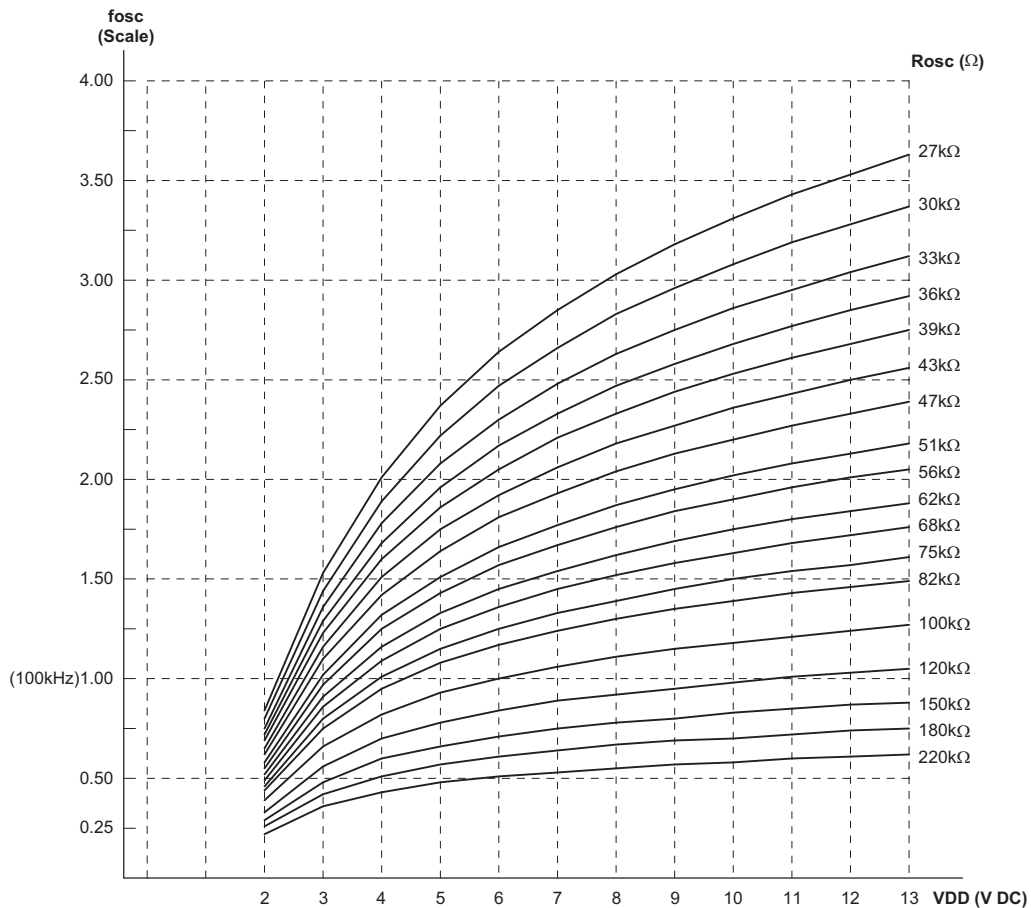
Oscillator Frequency Vs Supply Voltage

Note: The recommended oscillator frequency is f_{oscD} (decoder) $\cong 50 f_{oscE}$ (HT12E encoder)
 $\cong \frac{1}{3} f_{oscE}$ (HT12A encoder).

Application Circuits

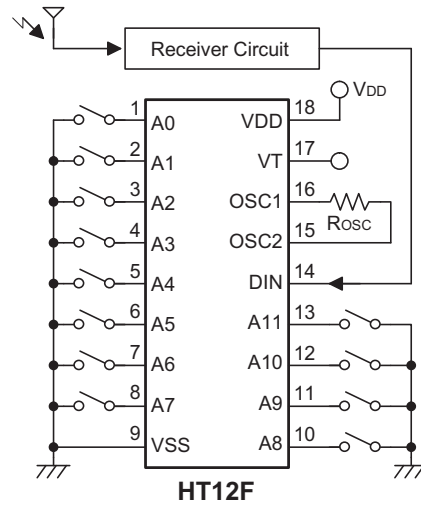
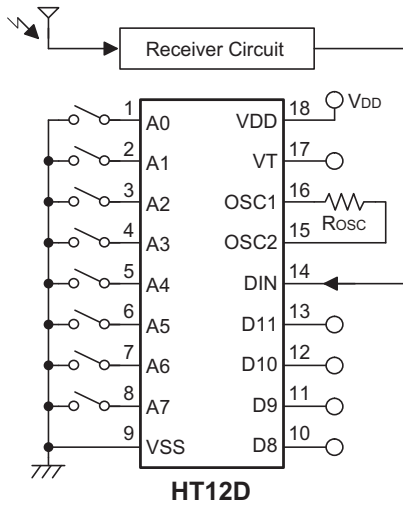

Package Information

18-pin DIP (300mil) Outline Dimensions

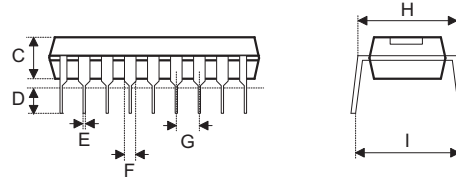
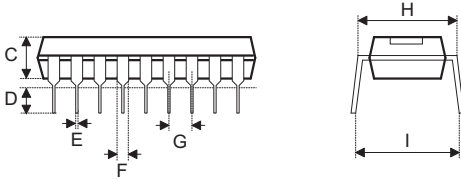
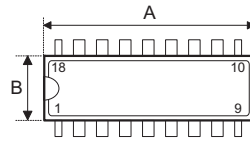
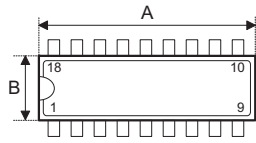

Fig1. Full Lead Packages

Fig2. 1/2 Lead Packages

- MS-001d (see fig1)

| Symbol | Dimensions in mil | | |
|--------|-------------------|------|------|
| | Min. | Nom. | Max. |
| A | 880 | — | 920 |
| B | 240 | — | 280 |
| C | 115 | — | 195 |
| D | 115 | — | 150 |
| E | 14 | — | 22 |
| F | 45 | — | 70 |
| G | — | 100 | — |
| H | 300 | — | 325 |
| I | — | — | 430 |

- MS-001d (see fig2)

| Symbol | Dimensions in mil | | |
|--------|-------------------|------|------|
| | Min. | Nom. | Max. |
| A | 845 | — | 880 |
| B | 240 | — | 280 |
| C | 115 | — | 195 |
| D | 115 | — | 150 |
| E | 14 | — | 22 |
| F | 45 | — | 70 |
| G | — | 100 | — |
| H | 300 | — | 325 |
| I | — | — | 430 |

- MO-095a (see fig2)

| Symbol | Dimensions in mil | | |
|--------|-------------------|------|------|
| | Min. | Nom. | Max. |
| A | 845 | — | 885 |
| B | 275 | — | 295 |
| C | 120 | — | 150 |
| D | 110 | — | 150 |
| E | 14 | — | 22 |
| F | 45 | — | 60 |
| G | — | 100 | — |
| H | 300 | — | 325 |
| I | — | — | 430 |

20-pin SOP (300mil) Outline Dimensions

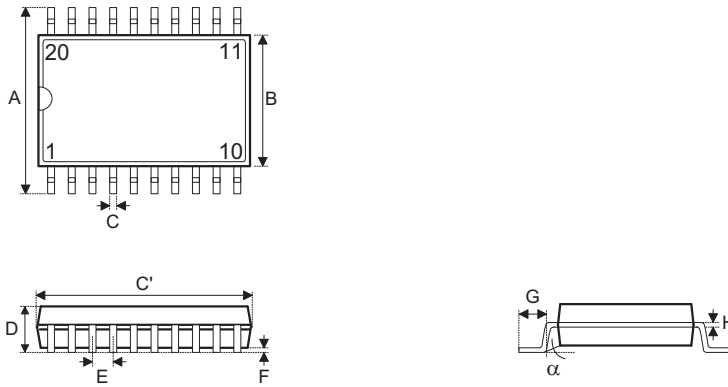

• MS-013

| Symbol | Dimensions in mil | | |
|--------|-------------------|------|------|
| | Min. | Nom. | Max. |
| A | 393 | — | 419 |
| B | 256 | — | 300 |
| C | 12 | — | 20 |
| C' | 496 | — | 512 |
| D | — | — | 104 |
| E | — | 50 | — |
| F | 4 | — | 12 |
| G | 16 | — | 50 |
| H | 8 | — | 13 |
| α | 0° | — | 8° |

Product Tape and Reel Specifications

Reel Dimensions

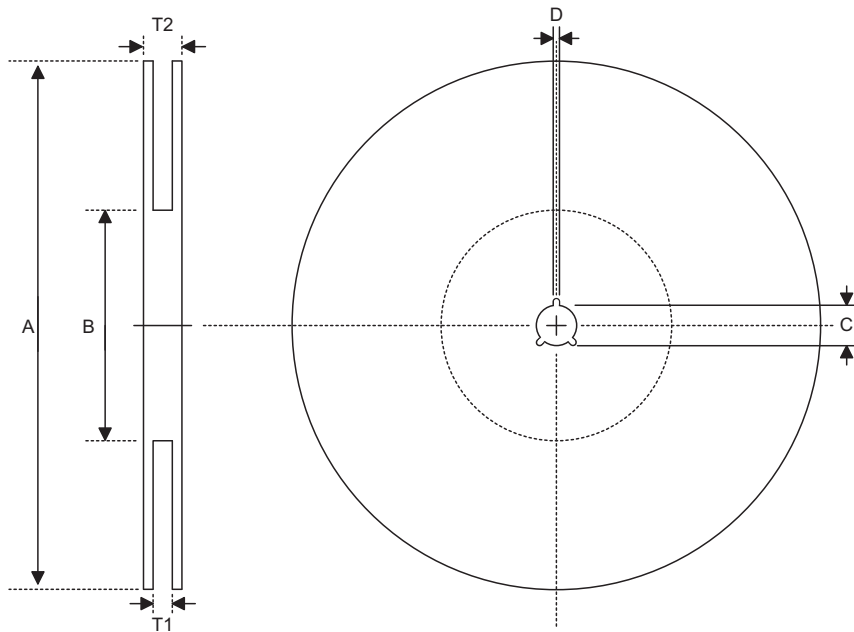

SOP 20W

| Symbol | Description | Dimensions in mm |
|--------|-----------------------|---------------------------|
| A | Reel Outer Diameter | 330.0±1.0 |
| B | Reel Inner Diameter | 100.0±1.5 |
| C | Spindle Hole Diameter | 13.0 ^{+0.5/-0.2} |
| D | Key Slit Width | 2.0±0.5 |
| T1 | Space Between Flange | 24.8 ^{+0.3/-0.2} |
| T2 | Reel Thickness | 30.2±0.2 |

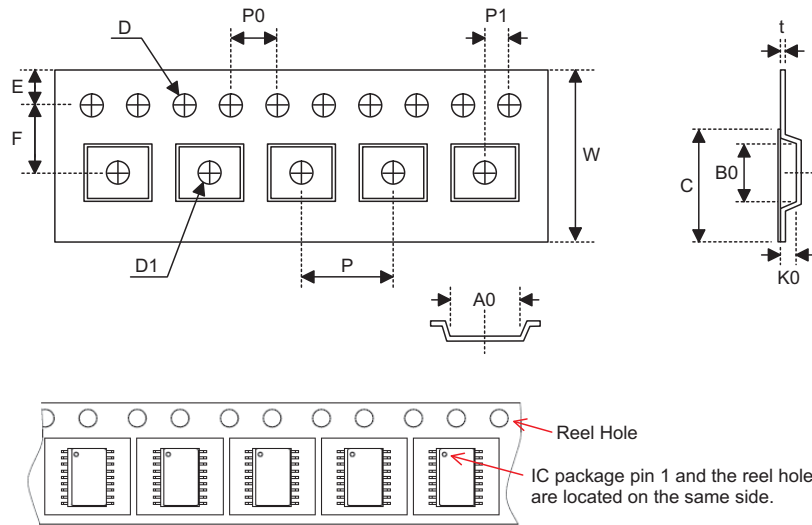
Carrier Tape Dimensions

SOP 20W

| Symbol | Description | Dimensions in mm |
|--------|--|-----------------------------|
| W | Carrier Tape Width | 24.0 ^{+0.3/-0.1} |
| P | Cavity Pitch | 12.0±0.1 |
| E | Perforation Position | 1.75±0.10 |
| F | Cavity to Perforation (Width Direction) | 11.5±0.1 |
| D | Perforation Diameter | 1.5 ^{+0.1/-0.0} |
| D1 | Cavity Hole Diameter | 1.50 ^{+0.25/-0.00} |
| P0 | Perforation Pitch | 4.0±0.1 |
| P1 | Cavity to Perforation (Length Direction) | 2.0±0.1 |
| A0 | Cavity Length | 10.8±0.1 |
| B0 | Cavity Width | 13.3±0.1 |
| K0 | Cavity Depth | 3.2±0.1 |
| t | Carrier Tape Thickness | 0.30±0.05 |
| C | Cover Tape Width | 21.3±0.1 |

Copyright © 2009 by HOLTEK SEMICONDUCTOR INC.

The information appearing in this Data Sheet is believed to be accurate at the time of publication. However, Holtek assumes no responsibility arising from the use of the specifications described. The applications mentioned herein are used solely for the purpose of illustration and Holtek makes no warranty or representation that such applications will be suitable without further modification, nor recommends the use of its products for application that may present a risk to human life due to malfunction or otherwise. Holtek's products are not authorized for use as critical components in life support devices or systems. Holtek reserves the right to alter its products without prior notification. For the most up-to-date information, please visit our web site at <http://www.holtek.com.tw>.