

Features

- Logic voltage: 3.0V~5.5V
- High-voltage output: V_{DD} -35V max.
- Multiple display (12-segment & 16-digit to 20-segment & 8-digit)
- 12x4 matrix key scanning
- 8 steps dimmer circuit
- 5 LED output ports (20mA max.)
- 4-bit general purpose input port
- No external resistors necessary for driver output (provides PMOS open-drain and pull-low resistor output)
- Serial interface with MCU (CLK, \overline{CS} , DI, DO)
- 52-pin QFP package

Applications

- Consumer products panel function control
- Industrial measuring instrument panel function control
- Other similar application panel function control

General Description

HT16511 is a VFD (Vacuum Fluorescent Display) controller/driver that is driven on a 1/8 to 1/16 duty factor. It consists of 12 segment output lines, 8 grid output lines, 8 segment/grid output drive lines, 5 LED output ports, a control circuit, a display memory, and a key scan circuit.

Serial data inputs to the HT16511 through a three-line serial interface. This VFD controller/driver is ideal as a peripheral device for an MCU.

Block Diagram

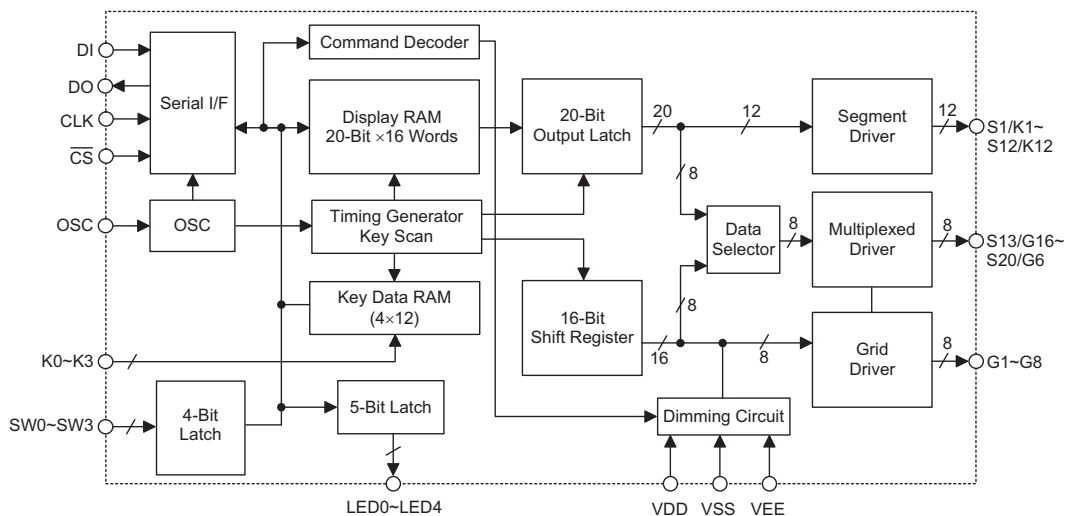

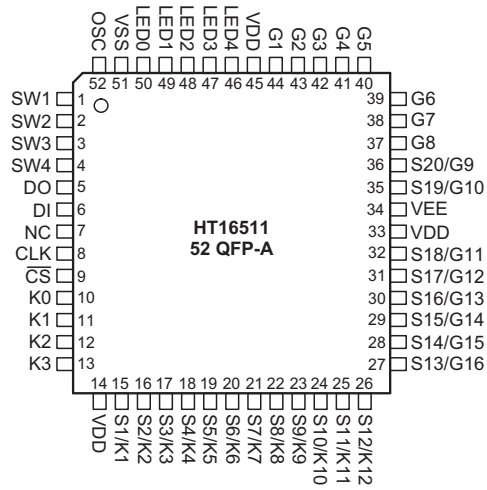
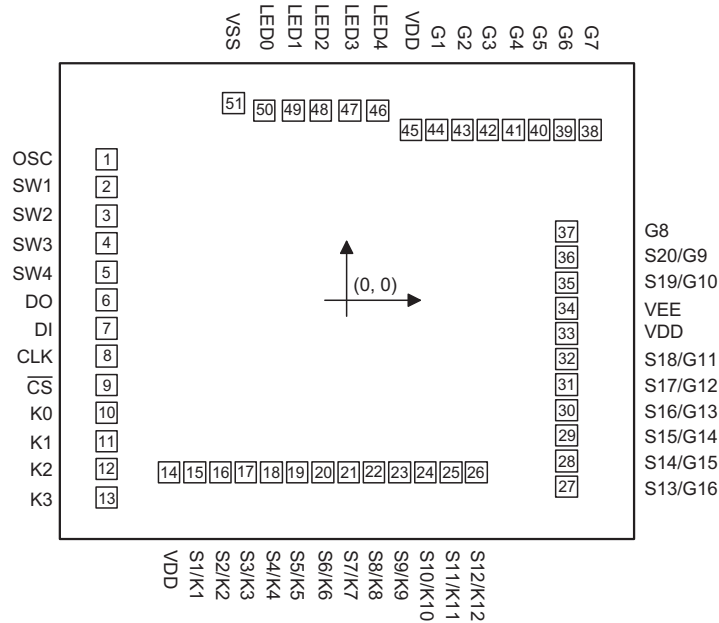
Pin Assignment

Pad Assignment

Chip Size: 1920 × 1599 (μm)²

* The IC substrate should be connected to VSS in the PCB layout artwork.

Pad Coordinates

 Unit: μm

Pad No.	X	Y	Pad No.	X	Y
1	-796.450	472.350	27	729.900	-618.350
2	-796.450	380.350	28	729.900	-533.350
3	-796.450	284.350	29	729.900	-448.350
4	-796.450	192.350	30	729.900	-363.350
5	-796.450	96.350	31	729.900	-278.350
6	-796.450	4.350	32	729.900	-193.350
7	-796.450	-91.650	33	729.900	-108.350
8	-796.450	-183.650	34	729.900	-23.600
9	-796.450	-279.650	35	729.900	61.650
10	-796.450	-371.650	36	729.900	146.650
11	-796.450	-467.650	37	729.900	231.650
12	-796.450	-559.650	38	808.200	569.900
13	-796.450	-655.650	39	723.200	569.900
14	-590.150	-570.250	40	638.200	569.900
15	-504.400	-570.250	41	553.200	569.900
16	-419.400	-570.250	42	468.200	569.900
17	-334.400	-570.250	43	383.200	569.900
18	-249.400	-570.250	44	298.200	569.900
19	-164.400	-570.250	45	213.200	569.900
20	-79.400	-570.250	46	102.900	633.950
21	5.600	-570.250	47	10.900	633.950
22	90.600	-570.250	48	-85.100	633.950
23	175.600	-570.250	49	-177.100	633.950
24	260.600	-570.250	50	-273.100	633.950
25	345.600	-570.250	51	-374.950	660.400
26	430.600	-570.250			

Pin Description

Pin No.	Pin Name	I/O	Description
1~4	SW1~SW4	I	4-bit general purpose input port
5	DO	O	Output serial data at the falling edge of the shift clock, starting from low order bit. This is an NMOS open-drain output pin.
6	DI	I	Input serial data at the rising edge of the shift clock, starting from the low order bit.
7	NC	—	No connection
8	CLK	I	Reads serial data at the rising edge, and outputs data at the falling edge.
9	$\overline{\text{CS}}$	I	Initializes serial interface at the rising or falling edge of the HT16511. Then it waits to receive a command. Data input after $\overline{\text{CS}}$ has fallen is processed as a command. While command data is processed, current processing is stopped, and the serial interface is initialized. While CS is high, CLK is ignored.
10~13	K0~K3	I	Keying data input to these pins is latched at the end of the display cycle.
14, 33, 45	VDD	—	Positive power supply
15~26	S1/K1~S12/K12	O	Segment or key source output pins (dual function). This is PMOS open-drain and pull-low resistor output.
27~32, 35~36	S13/G16~S20/G9	O	Segment or Grid driver output pins. These pins are selectable for segment or grid driving. This is PMOS open-drain and pull-low resistor output.
34	VEE	—	VFD power supply
37~44	G8~G1	O	Grid driver output pins (Grid only). This is PMOS open-drain and pull-low resistor output.
46~50	LED4~LED0	O	LED driver output ports. This is a CMOS output pin.
51	VSS	—	Negative power supply, ground
52	OSC	I	Connected to an external resistor or an RC oscillator circuit.

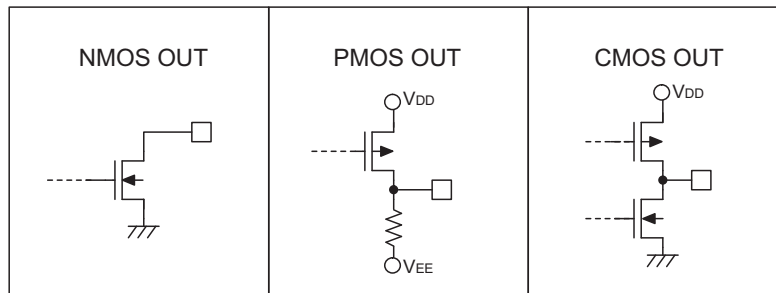
Approximate Internal Connections

Absolute Maximum Ratings

Supply Voltage	$V_{SS}-0.3V$ to $V_{SS}+6.0V$	Operating Temperature	$-25^{\circ}C$ to $75^{\circ}C$
Input Voltage	$V_{SS}-0.3V$ to $V_{DD}+0.3V$	Storage Temperature	$-50^{\circ}C$ to $125^{\circ}C$

Note: These are stress ratings only. Stresses exceeding the range specified under "Absolute Maximum Ratings" may cause substantial damage to the device. Functional operation of this device at other conditions beyond those listed in the specification is not implied and prolonged exposure to extreme conditions may affect device reliability.

D.C. Characteristics
 $T_a=25^{\circ}C$

Symbol	Parameter	Test Conditions		Min.	Typ.	Max.	Unit
		V_{DD}	Conditions				
V_{DD}	Logic Supply Voltage	3.3V	—	3.0	3.3	3.6	V
		5.0V		4.5	5.0	5.5	V
V_{EE}	VFD Supply Voltage	—	—	0	—	$V_{DD}-35$	V
f_{OSC}	Oscillation Frequency	3.3V	$R_{OSC}=51k\Omega$	480	565	650	kHz
		5.0V		465	545	630	kHz
R_{PL}	Output Pull-low Resistor	3.3V	Driver output	50	100	150	$k\Omega$
		5.0V					
I_{DD}	Operating Current	3.3V	No load, VFD display off	—	—	3	mA
		5.0V		—	—	5	mA
I_{OL}	Driver Leakage Current	3.3V	$V_O=V_{DD}-35V$, VFD driver off	—	—	-5	μA
		5.0V		—	—	-10	μA
I_{OL1}	LED Sink Current	3.3V	$V_{OL}=1.0V$, LED0~LED4	10	—	—	mA
		5.0V		20	—	—	mA
I_{OH1}	LED Source Current	3.3V	$V_{OH}=0.9V_{DD}$, LED0~LED4	-0.5	—	—	mA
		5.0V		-1.0	—	—	mA
I_{OH21}	Segment/Key Source Current	3.3V	$V_{OH}=V_{DD}-2V$ S1/K1~S12/K12	-1.5	—	—	mA
		5.0V		-3.0	—	—	mA
I_{OH22}	Segment/Grid Source Current	3.3V	$V_{OH}=V_{DD}-2V$	-7.5	—	—	mA
		5.0V		-15.0	—	—	mA
I_{OL3}	DO Sink Current	3.3V	$V_{OL}=0.4V$	2	—	—	mA
		5.0V		4	—	—	mA

Symbol	Parameter	Test Conditions		Min.	Typ.	Max.	Unit
		V _{DD}	Conditions				
V _{IH}	"H" Input Voltage	—	—	0.7V _{DD}	—	V _{DD}	V
V _{IL}	"L" Input Voltage	—	—	0	—	0.3V _{DD}	V
V _{OH1}	High-level Output Voltage	3.3V	LED0~LED4, I _{OH1} =-0.5mA	0.9V _{DD}	—	V _{DD}	V
		5.0V	LED0~LED4, I _{OH1} =-1mA				
V _{OL1}	Low-level Output Voltage	3.3V	LED0~LED4, I _{OL1} =10mA	0	—	1	V
		5.0V	LED0~LED4, I _{OL1} =20mA				
V _{OL2}	Low-level Output Voltage	3.3V	DO, I _{OL2} =2mA	0	—	0.4	V
		5.0V	DO, I _{OL2} =4mA				

A.C. Characteristics

Ta=25°C

Symbol	Parameter	Test Conditions		Min.	Typ.	Max.	Unit
		V _{DD}	Conditions				
t _{PHL}	Propagation Delay Time	3.3V	CLK→DO C _L =15pF, R _L =10kΩ	—	—	200	ns
		5.0V		—	—	100	ns
t _{PLH}		3.3V		—	—	600	ns
		5.0V		—	—	300	ns
t _{r1}	Rise Time	3.3V	C _L =300pF, S0~S12	—	—	4.0	μs
		5.0V		—	—	2.0	μs
t _{r2}		3.3V	C _L =300pF, G0~G16	—	—	1.0	μs
		5.0V		—	—	0.5	μs
t _f	Fall Time	3.3V	C _L =300pF, Sn, Gn	—	—	240	μs
		5.0V		—	—	120	μs
f _{max}	Maximum Clock Frequency	3.3V	Duty=50%	—	—	0.5	MHz
		5.0V		—	—	1.0	MHz
C _i	Input Capacitance	3.3V	—	—	—	15	pF
		5.0V		—	—	15	pF
t _{CW}	Clock Pulse Width	3.3V	—	800	—	—	ns
		5.0V		400	—	—	ns
t _{SW}	Strobe Pulse Width	3.3V	—	2	—	—	μs
		5.0V		1	—	—	μs
t _{SU}	Data Setup Time	3.3V	—	200	—	—	ns
		5.0V		100	—	—	ns
t _H	Data Hold Time	3.3V	—	200	—	—	ns
		5.0V		100	—	—	ns
t _{CS}	Clock-Strobe Time	3.3V	CLK rising edge to CS rising edge	2	—	—	μs
		5.0V		1	—	—	μs
t _W	Wait Time	3.3V	CLK rising edge to CLK falling edge	2	—	—	μs
		5.0V		1	—	—	μs

Functional Description

Display RAM and Display Mode

The static display RAM is organized into 40×8 bits and stores the data transmitted from an external device to the HT16511 through a serial interface. The contents of the RAM are directly mapped to the contents of the VFD driver. Data in the RAM can be accessed through the data setting, address setting and display control commands. It is assigned addresses in 8-bit unit as follows:

SEG1	SEG4	SEG8	SEG12	SEG16	SEG20	
00HL	00Hu	01HL	01Hu	02HL		DIG1
03HL	03Hu	04HL	04Hu	05HL		DIG2
06HL	06Hu	07HL	07Hu	08HL		DIG3
09HL	09Hu	0AHL	0AHu	0BHL		DIG4
0CHL	0CHu	0DHL	0DHu	0EHL		DIG5
0FHL	0FHu	10HL	10Hu	11HL		DIG6
12HL	12Hu	13HL	13Hu	14HL		DIG7
15HL	15Hu	16HL	16Hu	17HL		DIG8
18HL	18Hu	19HL	19Hu	1AHL		DIG9
1BHL	1BH <u>u</u>	1CHL	1CHu	1DHL		DIG10
1EHL	1EHu	1FHL	1FHu	20HL		DIG11
21HL	21Hu	22HL	22Hu	23HL		DIG12
24HL	24Hu	25HL	25Hu	26HL		DIG13
27HL	27Hu	28HL	28Hu	29HL		DIG14
2AHL	2AHu	2BHL	2BH <u>u</u>	2CHL		DIG15
2DHL	2DHu	2EHL	2EHu	2FHL		DIG16

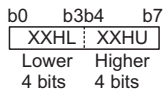

Note: Only the lower 4 bits of the addresses assigned to SEG17 through SEG20 are valid, the higher 4 bits are ignored.

Dimming Control

HT16511 provides 8-step dimmer function on display by controlling the 3-bit binary command code. The full pulse width of grid signal is divided into 16 uniform sections by PWM (pulse width modulation) technology.

The 16 uniform sections available form 8 steps dimmer via 3-bit binary code. The 8-step dimmer includes 1/16, 2/16, 4/16, 10/16, 11/16, 12/16, 13/16 and 14/16. The 1/16 pulse width indicates minimum lightness. The 14/16 pulse width represents maximum lightness (Refer to the display control command).

Key Matrix and Key-Input Data Storage RAM

The key matrix scans the series key states at each level of the key strobe signal (S1/K1~S12/K12) output of the HT16511. The key strobe signal outputs are time-multiplexed signals from S1/K1~S12/K12. The states of inputs K0~K3 are sampled by strobe signal S1/K1~S12/K12 and latched into the register.

The key matrix is made up of a 12×4 matrix, as shown below.

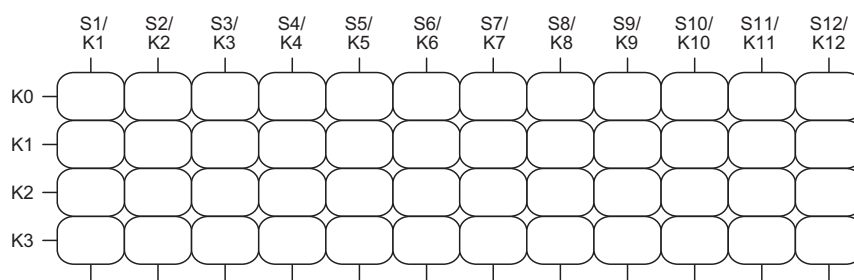

Detail

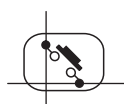

Key matrix

The data of each key is stored as illustrated below, and is read with the read command, starting from the least significant bit.

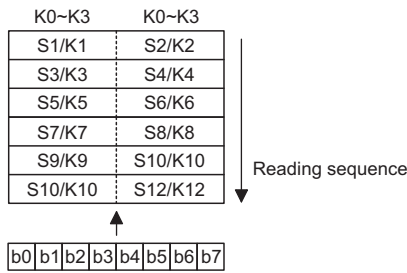

LED Port

The LED port belongs to the CMOS output configuration.

Data is written to the LED port with the write command, starting from the least port's least significant bit. In our application (see application circuits), the user adopts an internal NMOS device to a driver LED component by connecting VDD. When a bit of this port is 0, the corresponding LED lights; when the bit is 1, the LED turns off. The data of bits 6 through 8 are ignored.

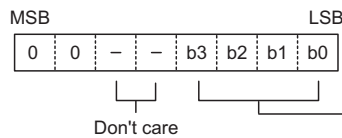
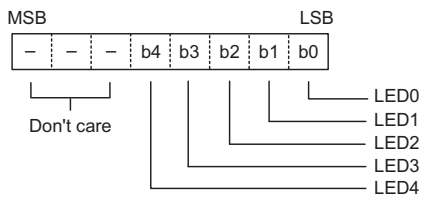

SW Data

The HT16511 provides an extra 4-bit general input port. The SW data is provided with available binary code. The SW data is read with the read command, starting from the least significant bit. Bits 5 through 8 of the SW data are 0.

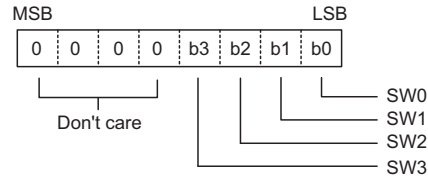

Commands

Commands set the display mode and status of the VFD driver.

The first 1 byte input to the HT16511 through the DI pin after the \overline{CS} pin has fallen, is regarded as a command. If \overline{CS} is set high while commands/data are transmitted, serial communication is initialized, and the commands/data being transmitted are not valid (however, the commands/data previously transmitted remains valid).

• Display mode setting commands

These commands initialize the HT16511 and select the number of segments and the number of grids (1/8~1/16 duty, 12 segments to 20 segments).

When these commands are executed, the display is forcibly turned off, and key scanning is also stopped.

To resume display, the display command "ON" must be executed. If the same mode is selected, nothing happens.

- Selects display mode
- 0xxx: 8 digits, 20 segments
 - 1000: 9 digits, 19 segments
 - 1001: 10 digits, 18 segments
 - 1010: 11 digits, 17 segments
 - 1011: 12 digits, 16 segments
 - 1100: 13 digits, 15 segments
 - 1101: 14 digits, 14 segments
 - 1110: 15 digits, 13 segments
 - 1111: 16 digits, 12 segments

Note: Power-on status: 16-digit, 12 segment mode is selected.

- Data setting commands

These commands set the data write and data read modes.

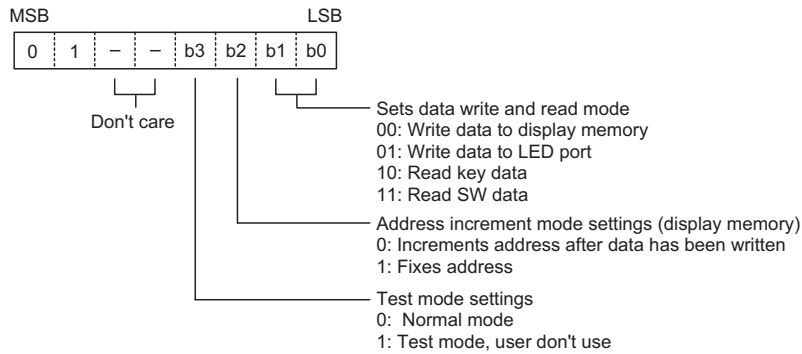

Note: power-on status: normal mode operation and address increment mode are set.

- Address setting commands

These commands set the address of the display memory.

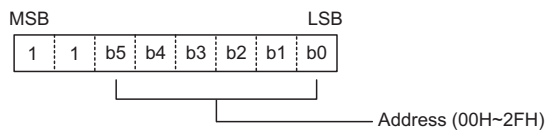

If address 30H or higher is set, data is ignored until a valid address is set.

Note: power-on status: the address is set to 00H.

- Display control commands

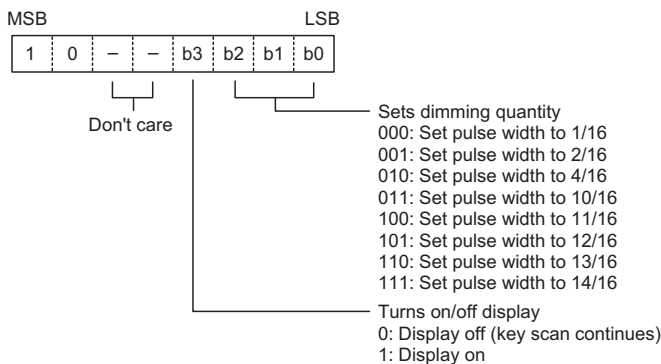

Note: power-on status: 1-16 pulse width is set and the display is turned off. Key scanning will be stopped during power

Timing Diagrams

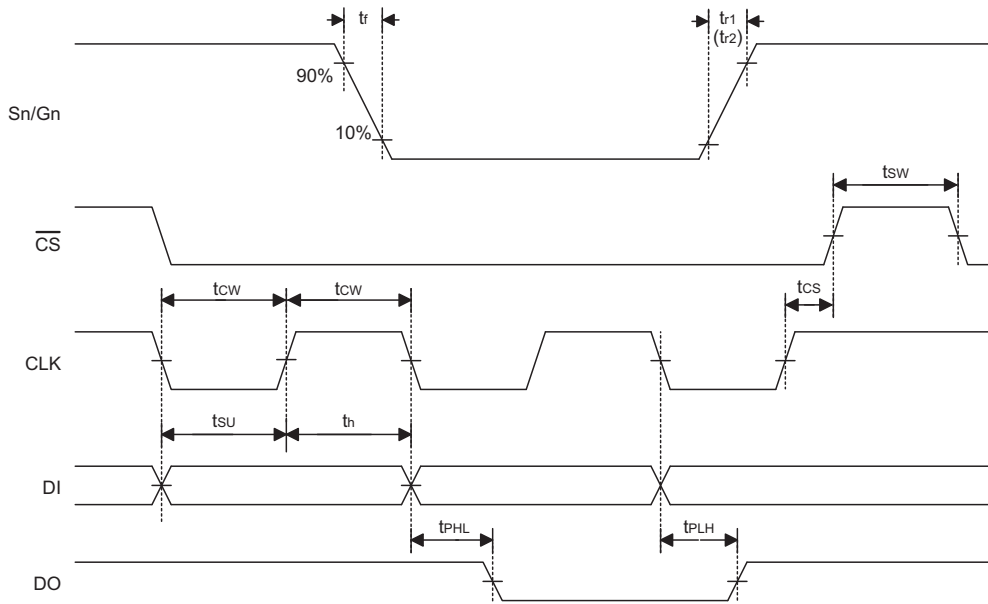

Key Scanning and Display Timing

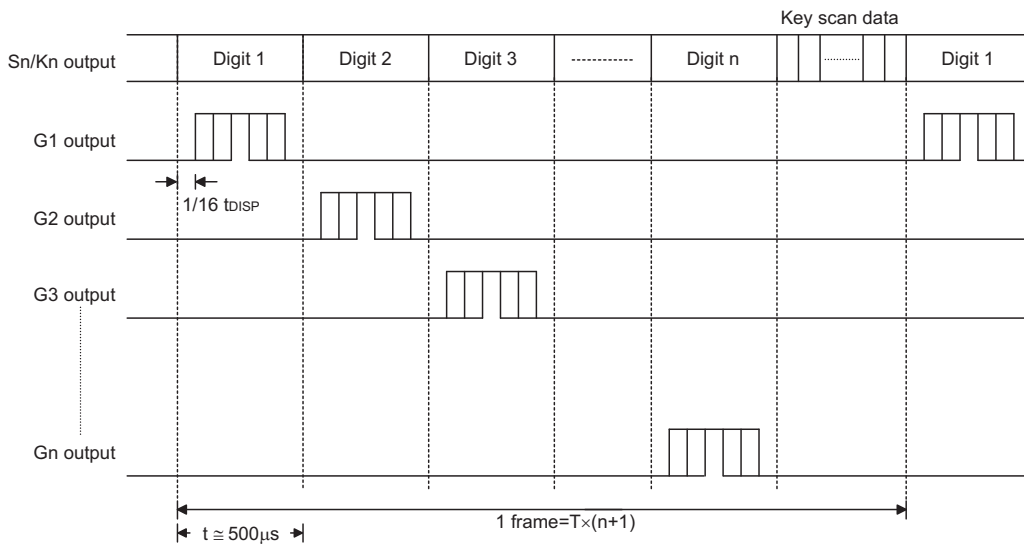

Note: One cycle of key scan consists of two frames, and data of 12×4 matrixes is stored in RAM.

Serial Communication Format

- Reception (command/data write)

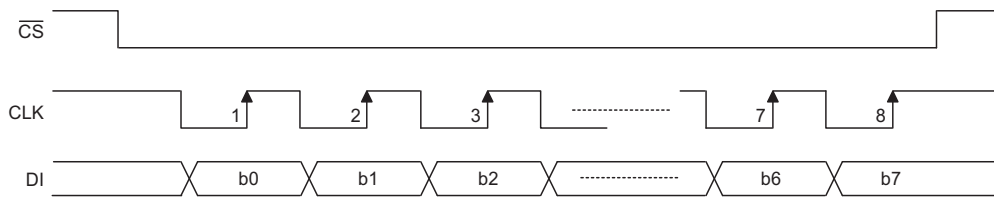

- Transmission (data read)

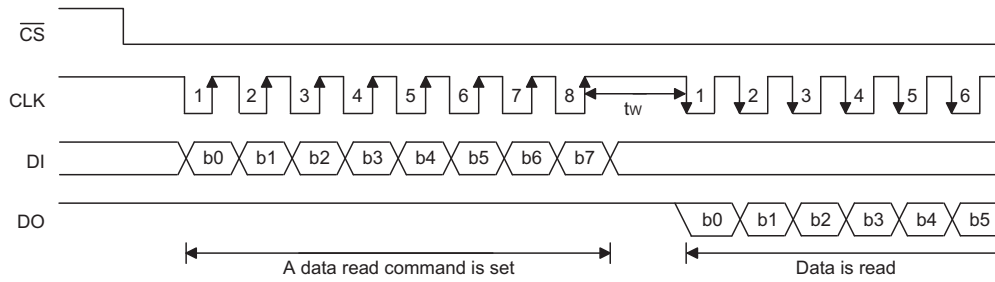

DO must be sure to connect an external pull-high resistor to this pin (1kΩ to 10kΩ).

Note: When data is read, a wait time "t_w" of 1μs is necessary.

- Updating display memory by incrementing address

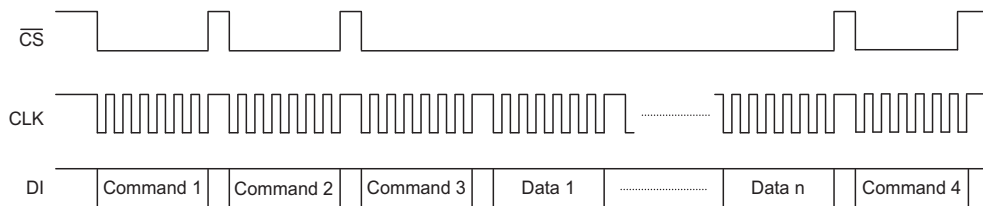

Note: Command 1: sets display mode
 Command 2: sets data
 Command 3: sets address
 Data 1 to n: transfers display data (48 bytes max.)
 Command 4: controls display

- Updating specific addresses

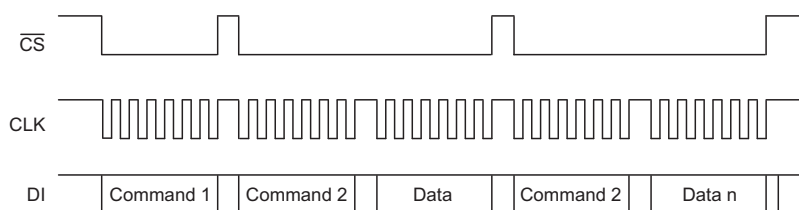

Note: Command 1: sets data
 Command 2: sets address
 Data: display data

Application Circuits

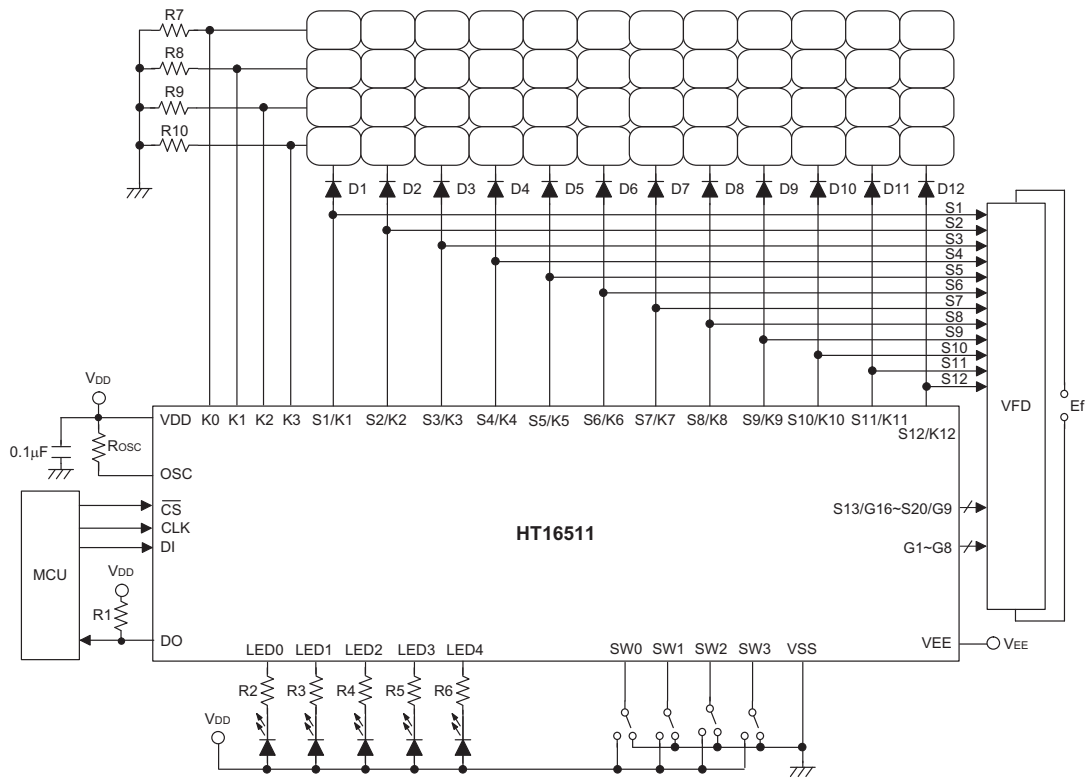

- Note:
- R_{OSC}=51kΩ for oscillator resistor
 - R1=1~10kΩ for external pull-high resistor
 - R2~R6=750Ω~1.2kΩ
 - R7~R10=10kΩ for external pull-low resistor
 - D1~D12=1N4001
 - Ef=Filament voltage for VFD

Package Information

Note that the package information provided here is for consultation purposes only. As this information may be updated at regular intervals users are reminded to consult the Holtek website (<http://www.holtek.com.tw/english/literature/package.pdf>) for the latest version of the package information.

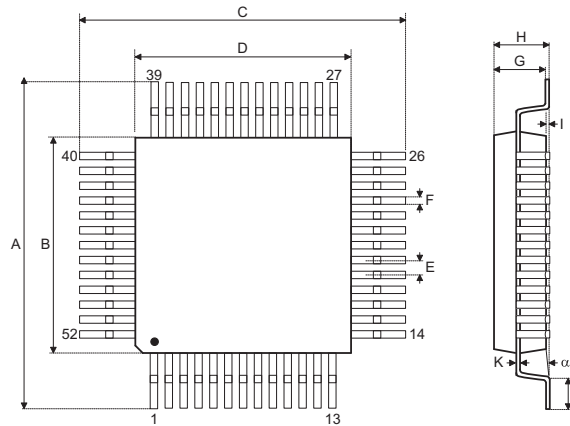
52-pin QFP (14mm×14mm) Outline Dimensions

Symbol	Dimensions in inch		
	Min.	Nom.	Max.
A	0.681	—	0.689
B	0.547	—	0.555
C	0.681	—	0.689
D	0.547	—	0.555
E	—	0.039	—
F	—	0.016	—
G	0.098	—	0.122
H	—	—	0.134
I	—	0.004	—
J	0.029	—	0.041
K	0.004	—	0.008
α	0°	—	7°

Symbol	Dimensions in mm		
	Min.	Nom.	Max.
A	17.30	—	17.50
B	13.90	—	14.10
C	17.30	—	17.50
D	13.90	—	14.10
E	—	1.00	—
F	—	0.40	—
G	2.50	—	3.10
H	—	—	3.40
I	—	0.10	—
J	0.73	—	1.03
K	0.10	—	0.20
α	0°	—	7°

Copyright © 2011 by HOLTEK SEMICONDUCTOR INC.

The information appearing in this Data Sheet is believed to be accurate at the time of publication. However, Holtek assumes no responsibility arising from the use of the specifications described. The applications mentioned herein are used solely for the purpose of illustration and Holtek makes no warranty or representation that such applications will be suitable without further modification, nor recommends the use of its products for application that may present a risk to human life due to malfunction or otherwise. Holtek's products are not authorized for use as critical components in life support devices or systems. Holtek reserves the right to alter its products without prior notification. For the most up-to-date information, please visit our web site at <http://www.holtek.com.tw>.