

### Features

- Operating voltage: 2.4V~5.5V
- Multiple LED display – 32 ROW /8 COM and 24 ROW & 16 COM
- Integrated display RAM – select 32 ROW & 8 COM for 64×4 display RAM, or select 24 ROW & 16 COM for 96×4 display RAM
- 16-level PWM brightness control
- Integrated 256kHz RC oscillator
- Serial MCU interface –  $\overline{CS}$ ,  $\overline{RD}$ ,  $\overline{WR}$ , DATA
- Data mode & command mode instruction
- Cascading function for extended applications
- Selectable NMOS open drain output driver and PMOS open drain output driver for commons
- 52-pin QFP package

### Applications

- Industrial control indicator
- Digital clock, thermometer, counter, voltmeter
- Instrumentation readouts
- Other consumer application
- LED Displays

### General Description

The HT1632C is a memory mapping LED display controller/driver, which can select a number of ROW and commons. These are 32 ROW & 8 commons and 24 ROW & 16 commons. The device supports 16-gradation LEDs for each out line using PWM control with software instructions. A serial interface is conveniently provided for the

command mode and data mode. Only three or four lines are required for the interface between the host controller and the HT1632C. The display can be extended by cascading the HT1632C for wider applications.

### Block Diagram

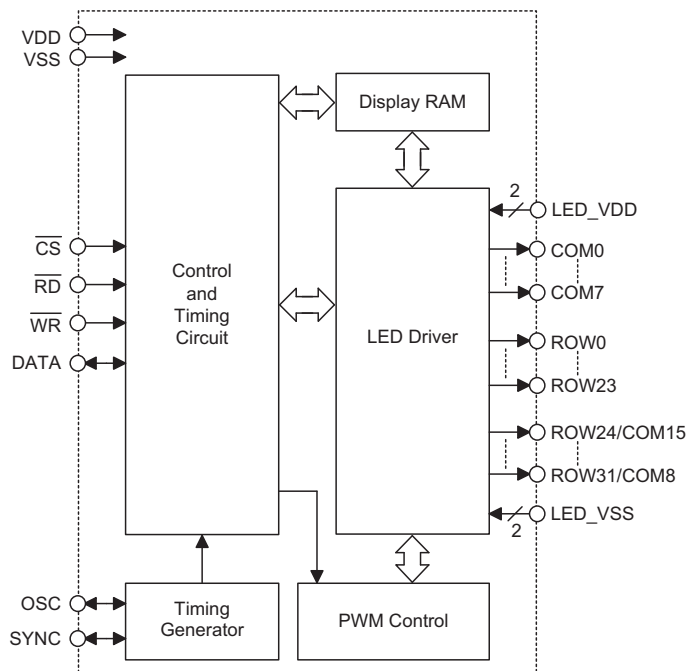

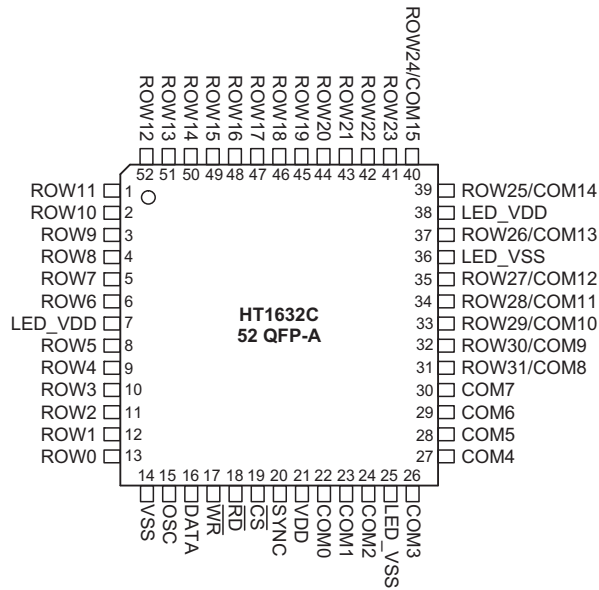
**Pin Assignment**

**Pin Description**

Pad Name	I/O	Description
ROW0~ROW23	O	Line drivers. These pins drive the LEDs.
ROW24/COM15~ROW31/COM8	O	Drive LED outputs or common outputs. Each COM pin is double bonded.
COM0~COM7	O	Common outputs. Each COM pin is double bonded.
SYNC	I/O	If the RC Master Mode or EXT CLK Master Mode command is programmed, the synchronous signal is output to SYN pin. If the Slave Mode command is programmed, the synchronous signal is input from SYN pin.
OSC	I/O	If the RC Master Mode command is programmed, the system clock source is from on-chip RC oscillator and system clock is output to OSC pin. If the Slave Mode or EXT CLK Master Mode command is programmed, the system clock source is input from external clock via the OSC pin.
DATA	I/O	Serial data input or output with pull-high resistor
$\overline{WR}$	I	WRITE clock input with pull-high resistor Data on the DATA lines are latched into the HT1632C on the rising edge of the $\overline{WR}$ signal.
$\overline{RD}$	I	READ clock input with pull-high resistor. The HT1632C RAM data is clocked out on the falling edge of the $\overline{RD}$ signal. The clocked out data will appear on the DATA line. The host controller can use the next rising edge to latch the clocked out data.
$\overline{CS}$	I	Chip select input with pull-high resistor When the $\overline{CS}$ line is high, the data and command read from or written to the HT1632C is disabled, and the serial interface circuit is also reset. If $\overline{CS}$ is low, the data and command transmission between the host controller and the HT1632C are all enabled.
LED_VDD	—	Positive power supply for driver circuit. Each LED_VDD pin is double bonded.
LED_VSS	—	Negative power supply for driver circuit, ground. Each LED_VSS pin is double bonded.
VSS	—	Negative power supply for logic circuit, ground.
VDD	—	Positive power supply for logic circuit.

**Absolute Maximum Ratings**

Supply Voltage .....  $V_{SS}-0.3V$  to  $V_{SS}+6.0V$       Storage Temperature .....  $-50^{\circ}C$  to  $125^{\circ}C$   
 Input Voltage .....  $V_{SS}-0.3V$  to  $V_{DD}+0.3V$       Operating Temperature .....  $-40^{\circ}C$  to  $85^{\circ}C$

Note: These are stress ratings only. Stresses exceeding the range specified under "Absolute Maximum Ratings" may cause substantial damage to the device. Functional operation of this device at other conditions beyond those listed in the specification is not implied and prolonged exposure to extreme conditions may affect device reliability.

**D.C. Characteristics**
 $V_{DD}=2.4V\sim 5.5V$ ,  $T_a=25^{\circ}C$  (Unless otherwise specified)

Symbol	Parameter	Test Conditions		Min.	Typ.	Max.	Unit
		$V_{DD}$	Conditions				
$V_{DD}$	Operating Voltage	—	—	2.4	5.0	5.5	V
$I_{DD}$	Operating Current	5V	No load, LED ON, on-chip RC oscillator	—	0.3	0.6	mA
$I_{STB}$	Standby Current	5V	No load, power down mode	—	1.5	3.0	$\mu A$
$V_{IL}$	Input Low Voltage	5V	DATA, $\overline{WR}$ , $\overline{CS}$ , $\overline{RD}$	0	—	$0.3V_{DD}$	V
$V_{IH}$	Input High Voltage	5V	DATA, $\overline{WR}$ , $\overline{CS}$ , $\overline{RD}$	$0.7V_{DD}$	—	5	V
$I_{OL1}$	OSC, SYNC, DATA	5V	$V_{OL}=0.5V$	18	25	—	mA
$I_{OH1}$	OSC, SYNC, DATA	5V	$V_{OH}=4.5V$	-10	-13	—	mA
$I_{OL2}$	ROW Sink Current	5V	$V_{OL}=0.5V$	12	16	—	mA
$I_{OH2}$	ROW Source Current	5V	$V_{OH}=4.5V$	-50	-70	—	mA
$I_{OL3}$	COM Sink Current	5V	$V_{OL}=0.5V$	250	350	—	mA
$I_{OH3}$	COM Source Current	5V	$V_{OH}=4.5V$	-45	-60	—	mA
$R_{PH}$	Pull-high Resistor	5V	DATA, $\overline{WR}$ , $\overline{CS}$ , $\overline{RD}$	18	27	40	$k\Omega$

**A.C. Characteristics**
 $V_{DD}=2.4V\sim 5.5V, T_a=25^{\circ}C$  (Unless otherwise specified)

Symbol	Parameter	Test Conditions		Min.	Typ.	Max.	Unit
		V <sub>DD</sub>	Conditions				
f <sub>SYS</sub>	System Clock	5V	On-chip RC oscillator	230	256	282	kHz
f <sub>LED</sub>	LED Duty Cycle & Frame Frequency	5V	1/8 duty	—	f <sub>SYS</sub> /2624	—	Hz
		5V	1/16 duty	—	f <sub>SYS</sub> /2624	—	Hz
f <sub>CLK1</sub>	Serial Data Clock ( $\overline{WR}$ pin)	5V	Duty cycle 50%	—	—	1	MHz
f <sub>CLK2</sub>	Serial Data Clock ( $\overline{RD}$ pin)	5V	Duty cycle 50%	—	—	500	kHz
t <sub>CS</sub>	Serial Interface Reset Pulse Width	—	$\overline{CS}$	250	—	—	ns
t <sub>CLK</sub>	$\overline{WR}, \overline{RD}$ Input Pulse Width	5V	Write mode	0.5	—	—	μs
			Read mode	1.0	—	—	
t <sub>r</sub> , t <sub>f</sub>	Rise/Fall Time Serial Data Clock Width (Figure 1)	—	—	—	50	100	ns
t <sub>su</sub>	Setup Time for DATA to $\overline{WR}, \overline{RD}$ , RD Clock Width (Figure 2)	—	—	50	100	—	ns
t <sub>h</sub>	Hold Time for DATA to $\overline{WR}, \overline{RD}$ , RD, Clock Width (Figure 2)	—	—	100	200	—	ns
t <sub>su1</sub>	Setup Time for $\overline{CS}$ to $\overline{WR}, \overline{RD}$ , Clock Width (Figure 3)	—	—	200	300	—	ns
t <sub>h1</sub>	Hold Time for $\overline{CS}$ to $\overline{WR}, \overline{RD}$ , Clock Width (Figure 3)	—	—	100	200	—	ns
t <sub>od</sub>	Data Output Delay Time (Figure 4)	—	—	—	100	200	ns

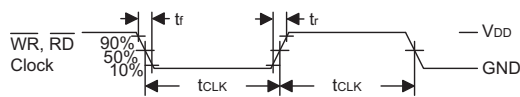
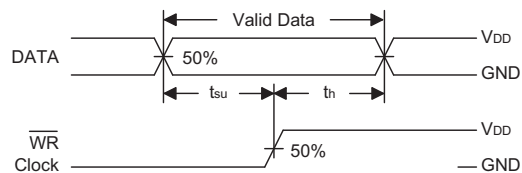
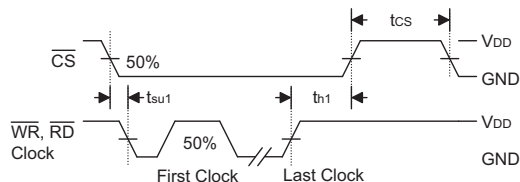
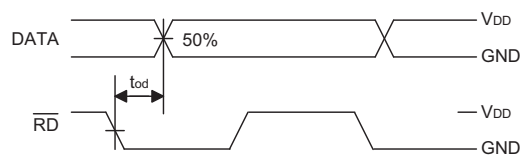
**Figure 1**

**Figure 2**

**Figure 3**

**Figure 4**

## Functional Description

### Display Memory – RAM

The static display memory (RAM) is organized into 64×4 bits or 96×4 bits and is used to store the display data. If 32 ROW & 8 COM is selected, the RAM size is 64×4 bits. If 24 ROW & 16 COM is selected, the RAM size is 96×4 bits. The contents of the RAM are directly mapped to the contents of the LED driver. If the data in RAM is

set to "1", the corresponding LED will be lighted. Data in the RAM can be accessed by the READ, WRITE, and READ-MODIFY-WRITE commands. The contents of the RAM can be read or written from bit 0 of the specific address. The following is a mapping from the RAM to the LED pattern:

	COM7	COM6	COM5	COM4	COM3	COM2	COM1	COM0		
ROW0					01H				00H	
ROW1					03H				02H	
ROW2					05H				04H	
ROW3					07H				06H	
ROW4					09H				08H	
ROW5					0BH				0AH	
ROW6					0DH				0CH	
ROW7					0FH				0EH	
ROW8					11H				10H	
ROW9					13H				12H	
ROW10					15H				14H	
ROW11					17H				16H	
ROW12					19H				18H	
ROW13					1BH				1AH	
ROW14					1DH				1CH	
ROW15					1FH				1EH	
ROW16					21H				20H	
ROW17					23H				22H	
ROW18					25H				24H	
ROW19					27H				26H	
ROW20					29H				28H	
ROW21					2BH				2AH	
ROW22					2DH				2CH	
ROW23					2FH				2EH	
ROW24					31H				30H	
ROW25					33H				32H	
ROW26					35H				34H	
ROW27					37H				36H	
ROW28					39H				38H	
ROW29					3BH				3AH	
ROW30					3DH				3CH	
ROW31					3FH				3EH	
	D3	D2	D1	D0	Addr. Data	D3	D2	D1	D0	Addr. Data



32 ROW & 8 COM for 64×4 Display RAM

	COM15	COM14	COM13	COM12	.....	COM3	COM2	COM1	COM0	
ROW0										00H
ROW1										04H
ROW2										08H
ROW3										0CH
ROW4										10H
ROW5										14H
ROW6										18H
ROW7										1CH
ROW8										20H
ROW9										24H
ROW10										28H
ROW11					.....					2CH
ROW12										30H
ROW13										34H
ROW14										38H
ROW15										3CH
ROW16										40H
ROW17										44H
ROW18										48H
ROW19										4CH
ROW20										50H
ROW21										54H
ROW22										58H
ROW23					.....					5CH
	D3	D2	D1	D0	Addr. Data	D3	D2	D1	D0	Addr. Data



**24 ROW & 16 COM for 96x4 Display RAM**

**System Oscillator**

The HT1632C system clock is used to generate the time base clock frequency, LED-driving clock. The clock may be sourced from an on-chip RC oscillator (256kHz), or an external clock using the S/W setting. The configuration of the system oscillator is as shown. After the SYS DIS command is executed, the system clock will stop and the LED duty cycle generator will turn off. This command is, however, available only for the on-chip RC oscillator. Once the system clock stops, the LED display will become blank, and the time base will also lose its function. The LED OFF command is used to turn the LED duty cycle generator off. After the LED duty cycle generator switches off by issuing the LED OFF command, using the SYS DIS command reduces power consumption, serving as a system power down command. But if the external clock source is chosen as the system clock, using the SYS DIS command can neither turn the oscillator off nor execute the power down mode. The crystal oscillator option can be applied to connect an external frequency source to the OSC pin. In this case, the system fails to enter the power down mode, similar to the case in the external clock source operation. At the initial system power on, the HT1632C is in the SYS DIS state.

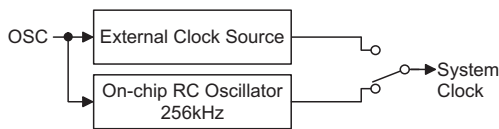

**System Oscillator Configuration**

**LED Driver**

The HT1632C has a 256 (32x8) and 384 (24x16) pattern LED driver. It can be configured in a 32x8 or 24x16 pattern and common pad N-MOS open drain output or P-MOS open drain output LED driver using the S/W configuration. This feature makes the HT1632C suitable for multiple LED applications. The LED-driving clock is derived from the system clock. The driving clock frequency is always 256kHz, an on-chip RC oscillator frequency, or an external frequency. The LED corresponding commands are summarized in the table. The bold form of 1 0 0, namely 1 0 0, indicates the command mode ID. If successive commands have been issued, the command mode ID except for the first command will be omitted. The

LED OFF command turns the LED display off by disabling the LED duty cycle generator. The LED ON command, on the other hand, turns the LED display on by enabling the LED duty cycle generator.

Name	Command Code	Function
LED OFF	<b>1000000010X</b>	Turn off LED outputs
LED ON	<b>1000000011X</b>	Turn on LED outputs
Commons Option	<b>1000010abXXX</b>	ab=00: N-MOS open drain output and 8 common option ab=01: N-MOS open drain output and 16 common option ab=10: P-MOS open drain output and 8 common option ab=11: P-MOS open drain output and 16 common option

**Cascade Operation**

For the cascade operation, the first IC is set to master mode and its SYNC and OSC pins are set to output pins. The second IC is set to slave mode and its SYNC and OSC pins are set to input pins which are connected to the master IC. Please refer to the "Cascade control flow chart" for detail settings.

**Blinker**

The HT1632C has display blinking capabilities. The blink function generates all LED blinking. The blink rates is 0.25s LED on and 0.25s LED off for one blinking period. This blinking function can be effectively performed by setting the BLINK ON or BLINK OFF command.

**Command Format**

The S/W setting can configure the HT1632C. There are two mode commands to configure the HT1632C resources and to transfer the LED display data. The configuration mode of the HT1632C is known as the command mode, with a command mode ID of 1 0 0. The command mode consists of a system configuration command, a system frequency selection command, a LED configuration command, and an operating command. The data mode, on the other hand, includes READ, WRITE, and READ-MODIFY-WRITE operations.

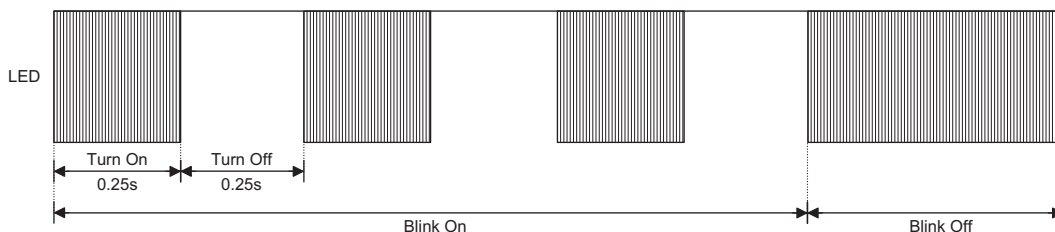

**Example of Waveform for Blinker**

**LED Driver Mode output Waveform**

- N-MOS open drain of 32x8 driver mode

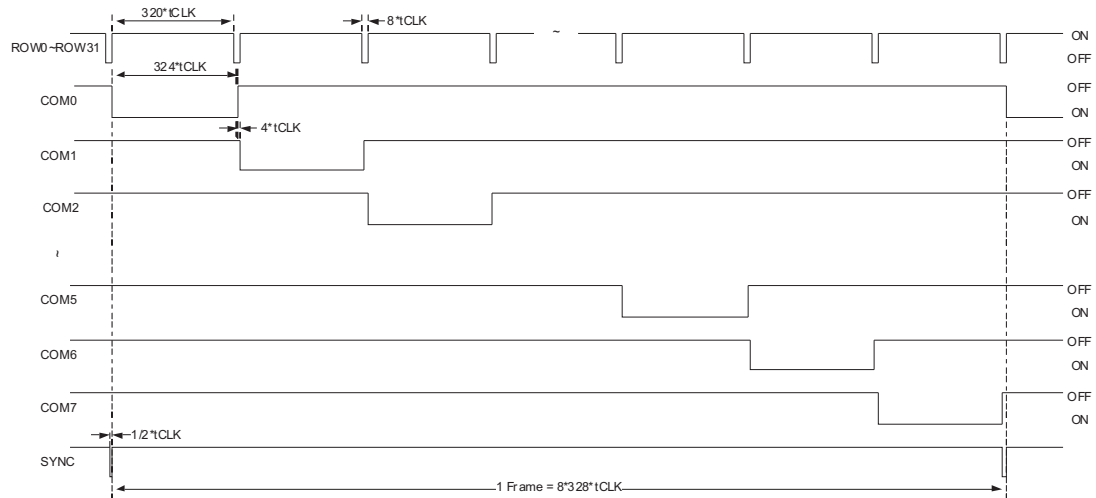

Note:  $t_{CLK} = 1/f_{SYS}$

- P-MOS open drain of 24x16 driver mode: (COM pin with Transistor Buffer)

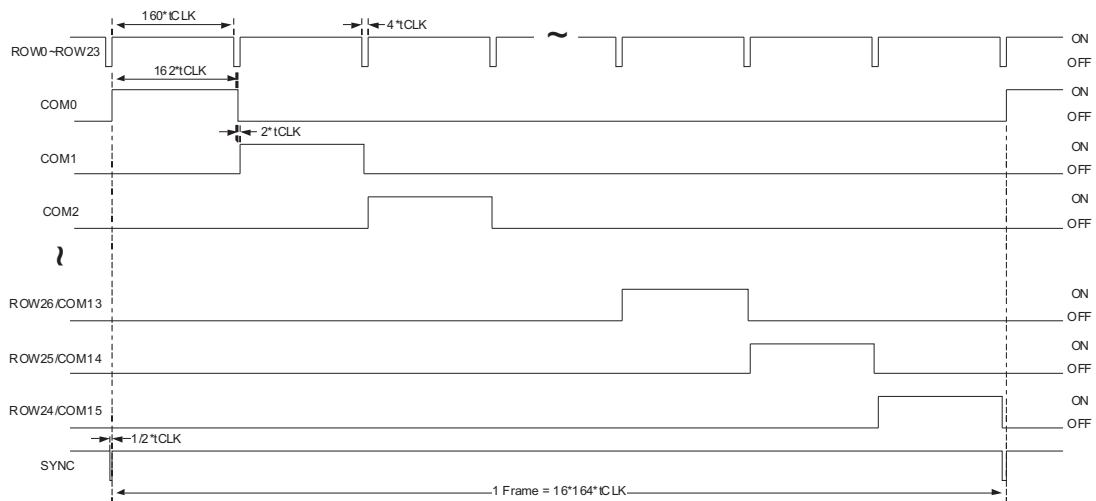

Note:  $t_{CLK} = 1/f_{SYS}$

**Digital Dimming**

The Display Dimming capabilities of the HT1632 are very versatile. The whole display can be dimmed using pulse width modulation techniques for the ROW driver with the Dimming command. The relationship between ROW and COM digital dimming duty time are shown as below:

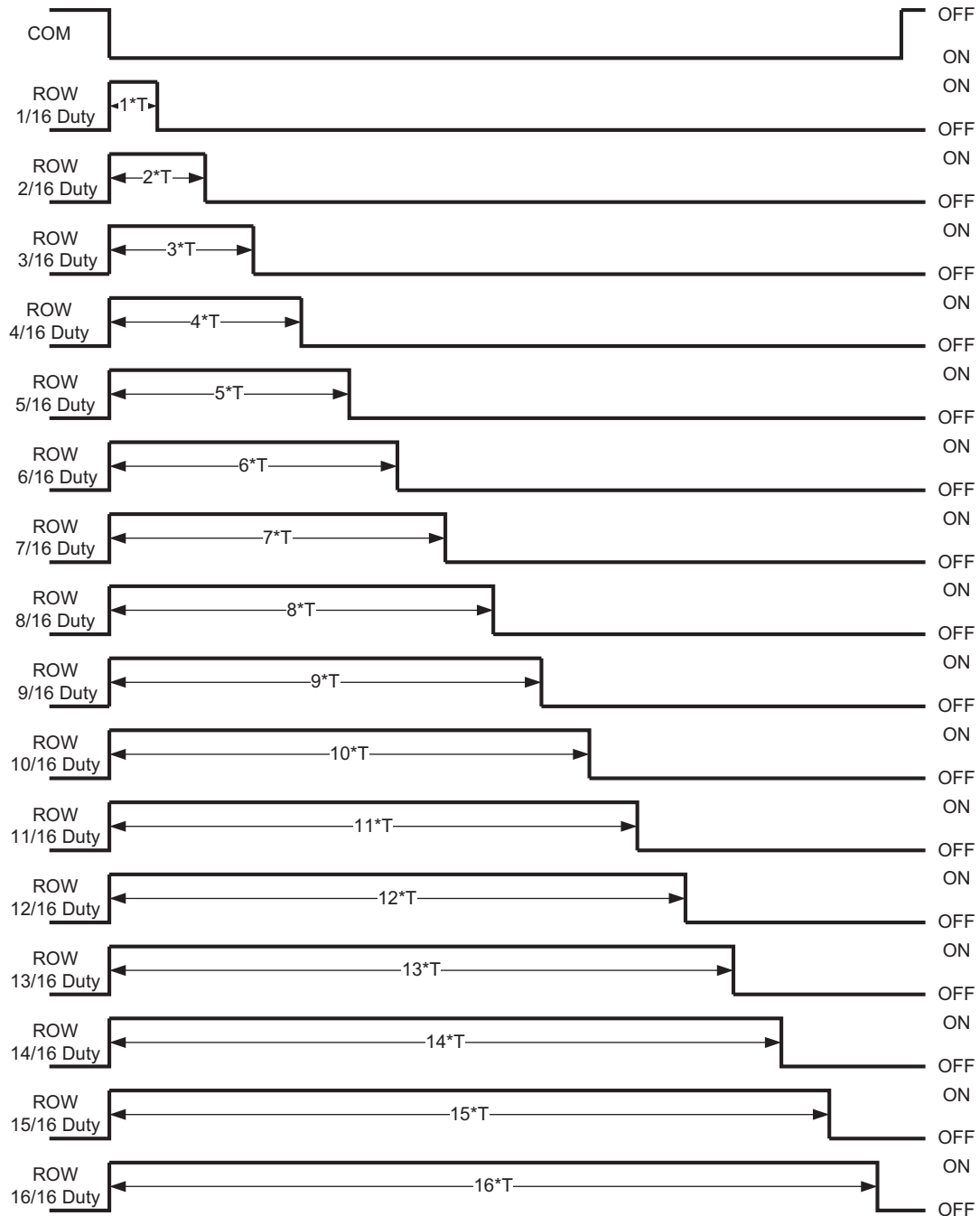

Note: (1)  $T = 20 \times t_{CLK}$  (32x8 driver mode)  
 (2)  $T = 10 \times t_{CLK}$  (24x16 driver mode)  
 (3)  $t_{CLK} = 1/f_{sys}$

The following are the data mode ID and the command mode ID:

Operation	Mode	ID
Read	Data	1 1 0
Write	Data	1 0 1
Read-Modify-Write	Data	1 0 1
Command	Command	1 0 0

The mode command should be issued before the data or command is transferred. If successive commands have been issued, the command mode ID, namely 1 0 0, can be omitted. While the system is operating in the non-successive command or the non-successive address data mode, the  $\overline{CS}$  pin should be set to "1" and the previous operation mode will be reset also. Once the  $\overline{CS}$  pin returns to "0", a new operation mode ID should be issued first.

### Interfacing

Only four lines are required to interface to the HT1632C. The  $\overline{CS}$  line is used to initialise the serial interface circuit and to terminate the communication between the host controller and the HT1632C. If the  $\overline{CS}$  pin is set to 1, the data and command issued between the host controller and the HT1632C are first disabled and then initialised. Before issuing a mode command or mode switching, a high level pulse is required to initialise the serial interface of the HT1632C. The DATA line is the serial data input/output line. Data to be read or written or commands to be written have to be passed through the DATA line. The  $\overline{RD}$  line is the READ clock input. Data in the RAM is clocked out on the falling edge of the  $\overline{RD}$  signal, and the clocked out data will then appear on the DATA line. It is recommended that the host controller reads in the correct data during the interval between the rising edge and the next falling edge of the  $\overline{RD}$  signal. The  $\overline{WR}$  line is the WRITE clock input. The data, address, and command on the DATA line are all clocked into the HT1632C on the rising edge of the  $\overline{WR}$  signal.

### Timing Diagrams

#### READ Mode – Command Code = 1 1 0

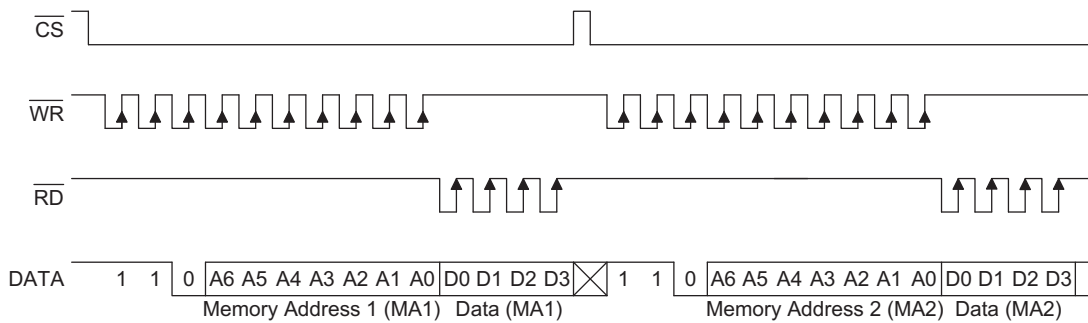

#### READ Mode – Successive Address Reading

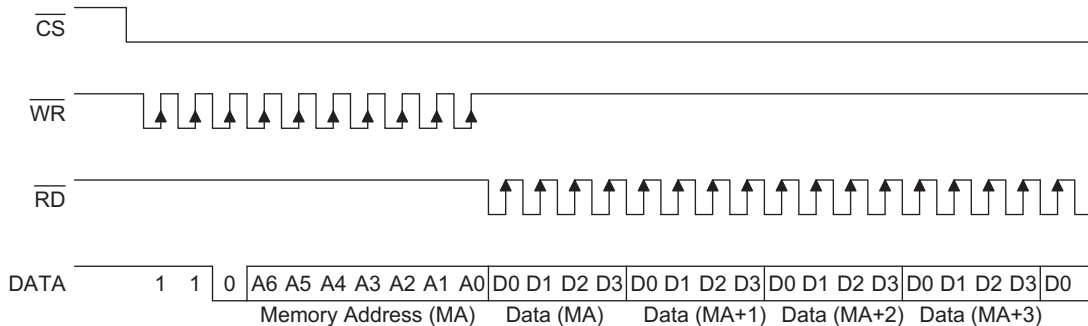

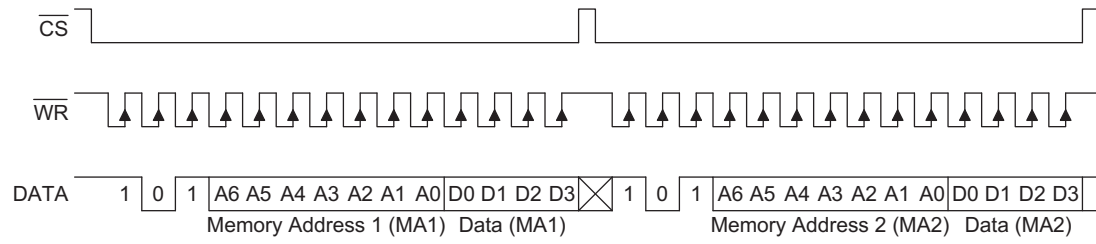
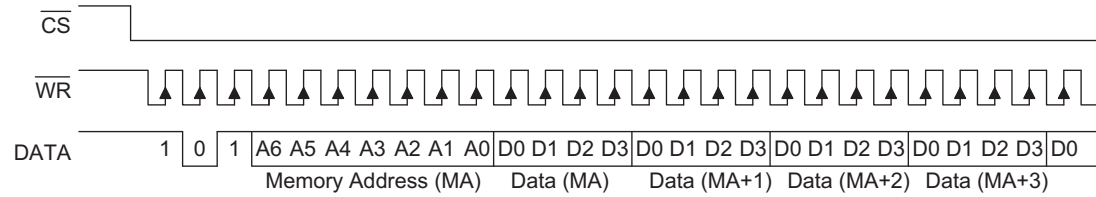
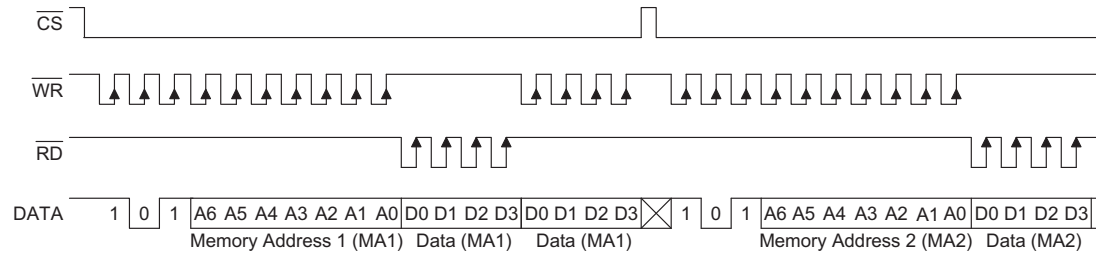
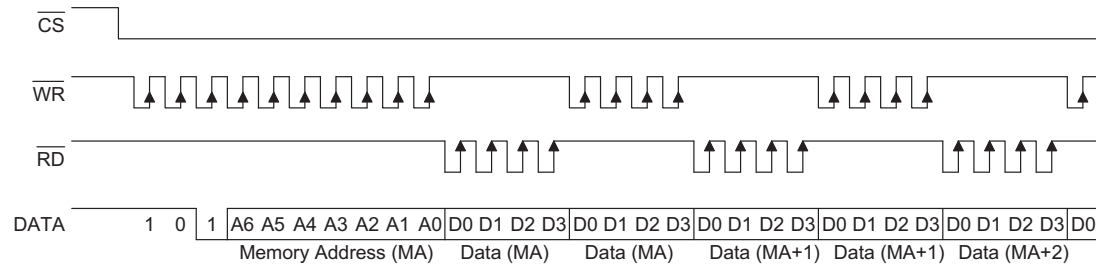
**WRITE Mode – Command Code = 1 0 1**

**WRITE Mode – Successive Address Writing**

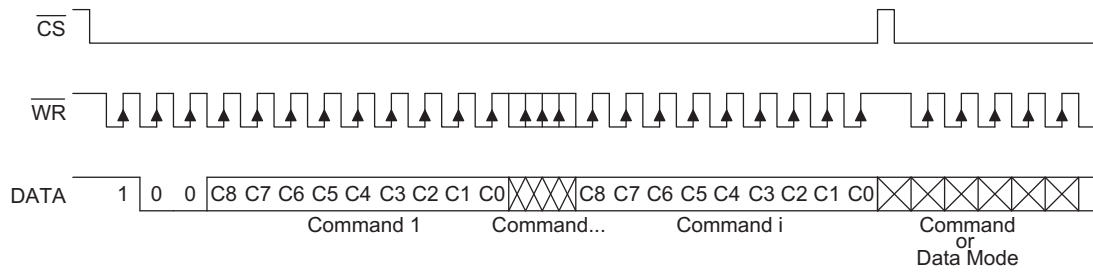
**READ-MODIFY-WRITE Mode – Command Code = 1 0 1**

**READ-MODIFY-WRITE Mode – Successive Address Accessing**

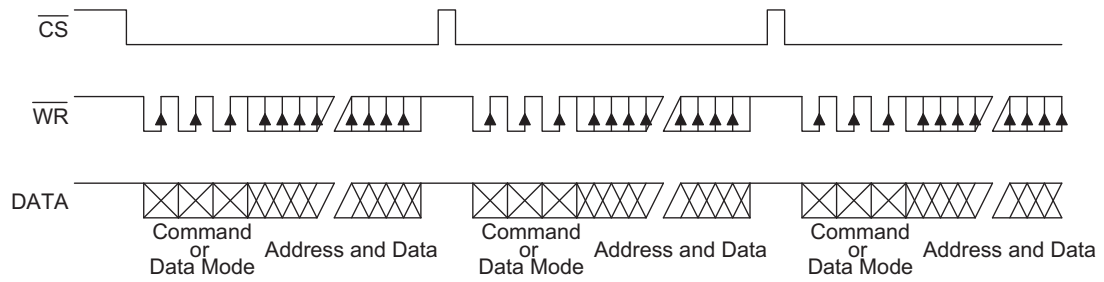
**Command Mode – Command Code = 1 0 0**



**Mode – Data and Command Mode**



**Application Circuits**

**Low Power LED Application (Direct Drive)**

- 32 ROW × 8 COM example

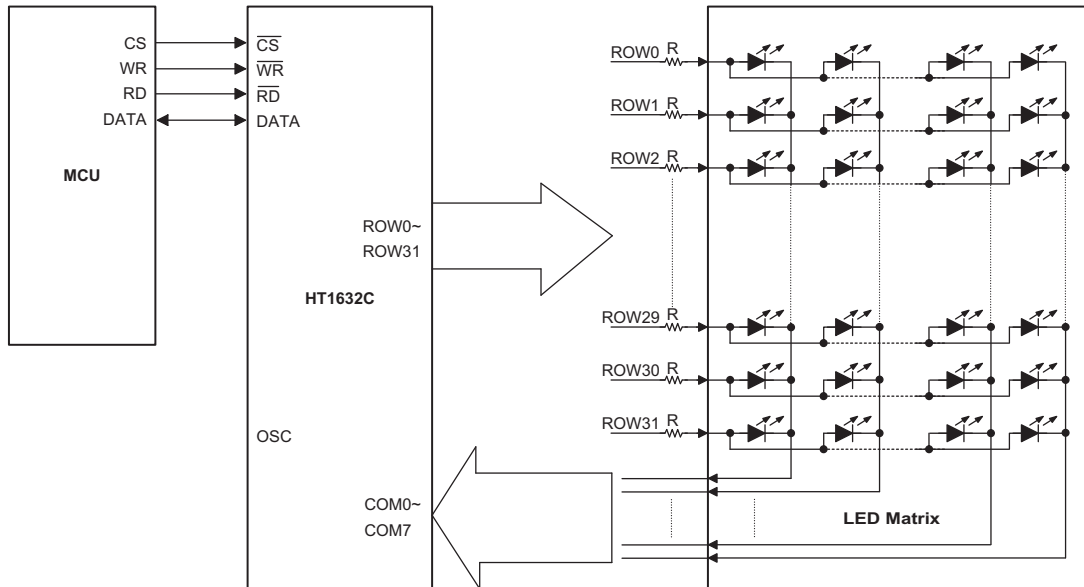

Note: Values of the "R" resistors are selected depending on the power consumption of the LEDs.

- 24 ROW × 16 COM example

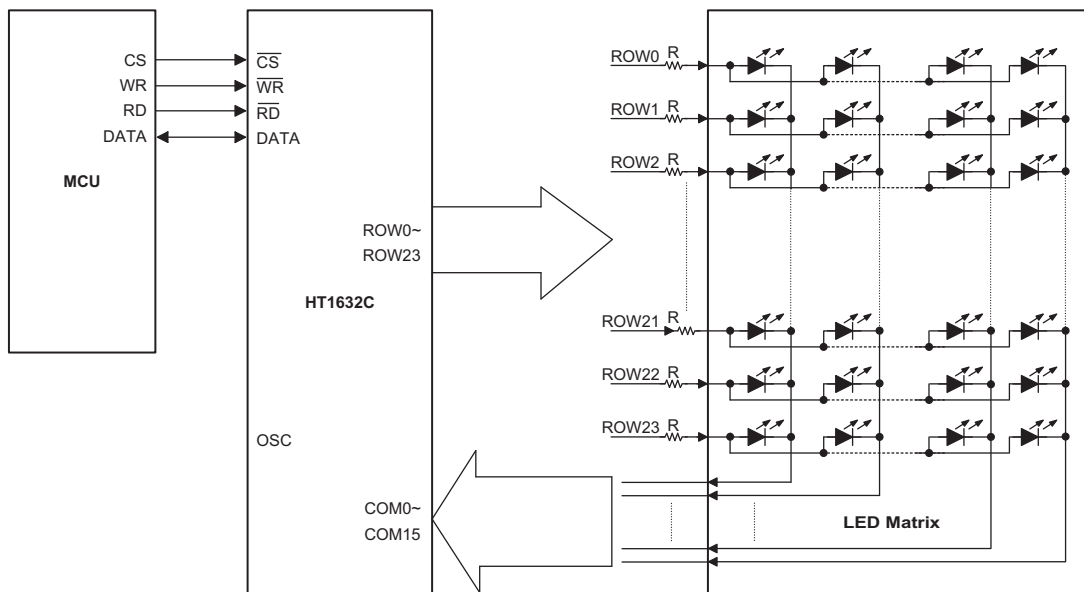

Note: Values of the "R" resistors are selected depending on the power consumption of the LEDs.

**Middle Power LED Application (COM with Transistor Buffer)**

- 32 ROW × 8 COM example

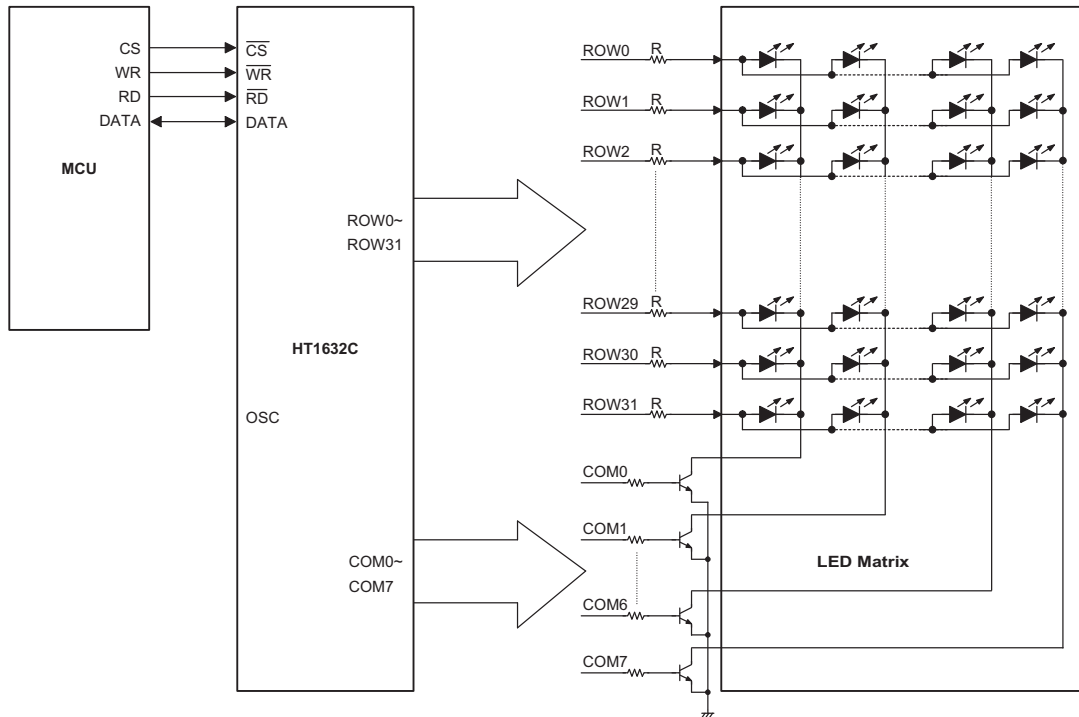

Note: Values of the "R" resistors are selected depending on the power consumption of the LEDs.

- 24 ROW × 16 COM example

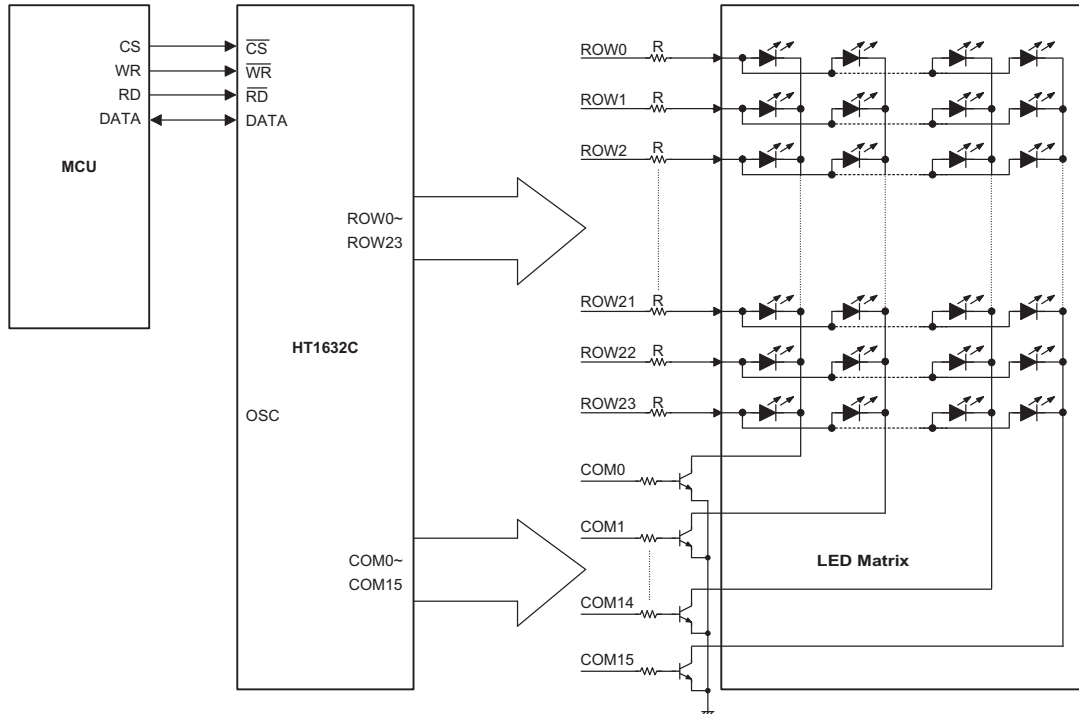

Note: Values of the "R" resistors are selected depending on the power consumption of the LEDs.

High Power LED Application (ROW & COM with Transistor Buffer)

- 32 ROW × 8 COM example

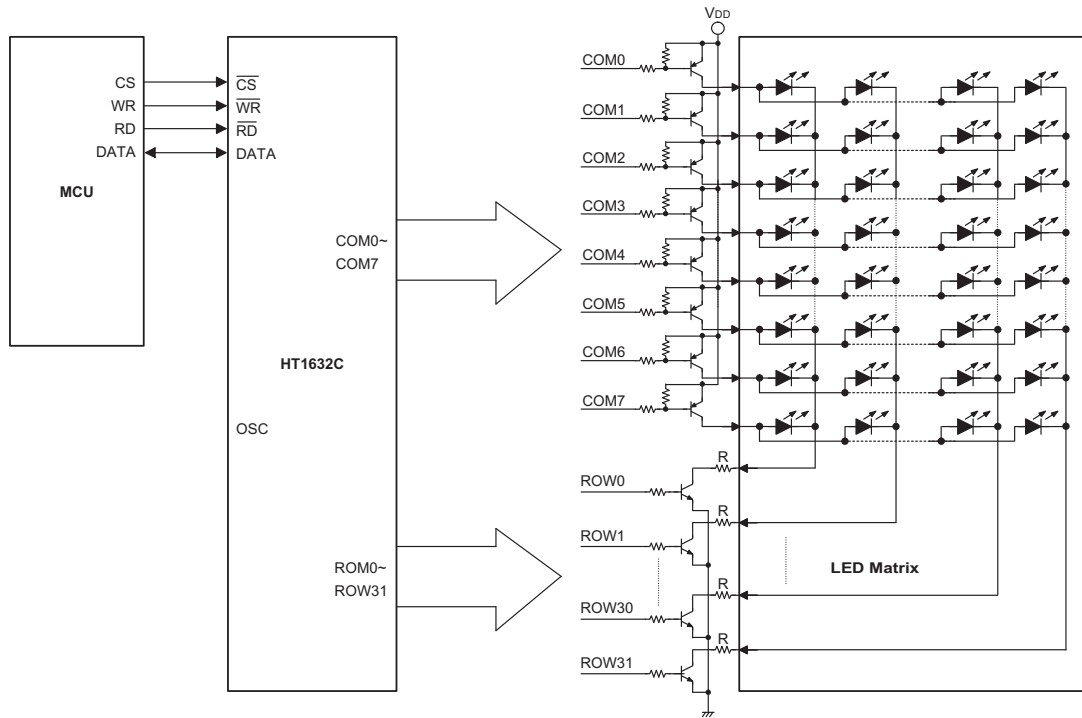

Note: Values of the "R" resistors are selected depending on the power consumption of the LEDs.

- 24 ROW × 16 COM example

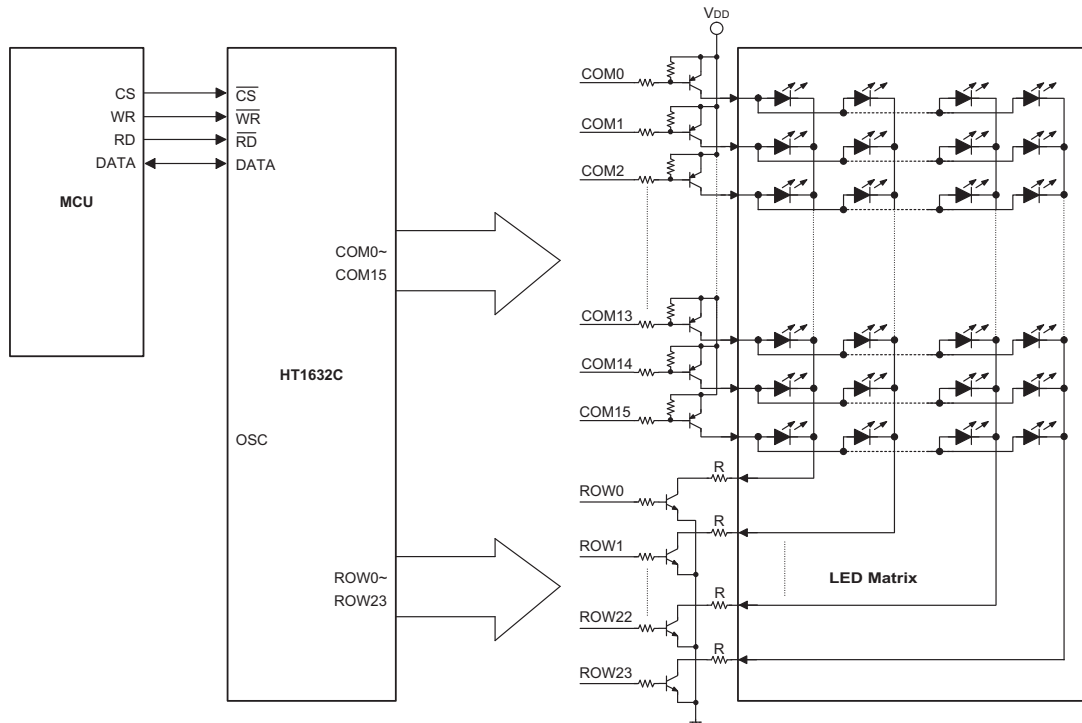

Note: Values of the "R" resistors are selected depending on the power consumption of the LEDs.

**Cascade Function**

- 32 ROW × 8 COM example (direct drive)

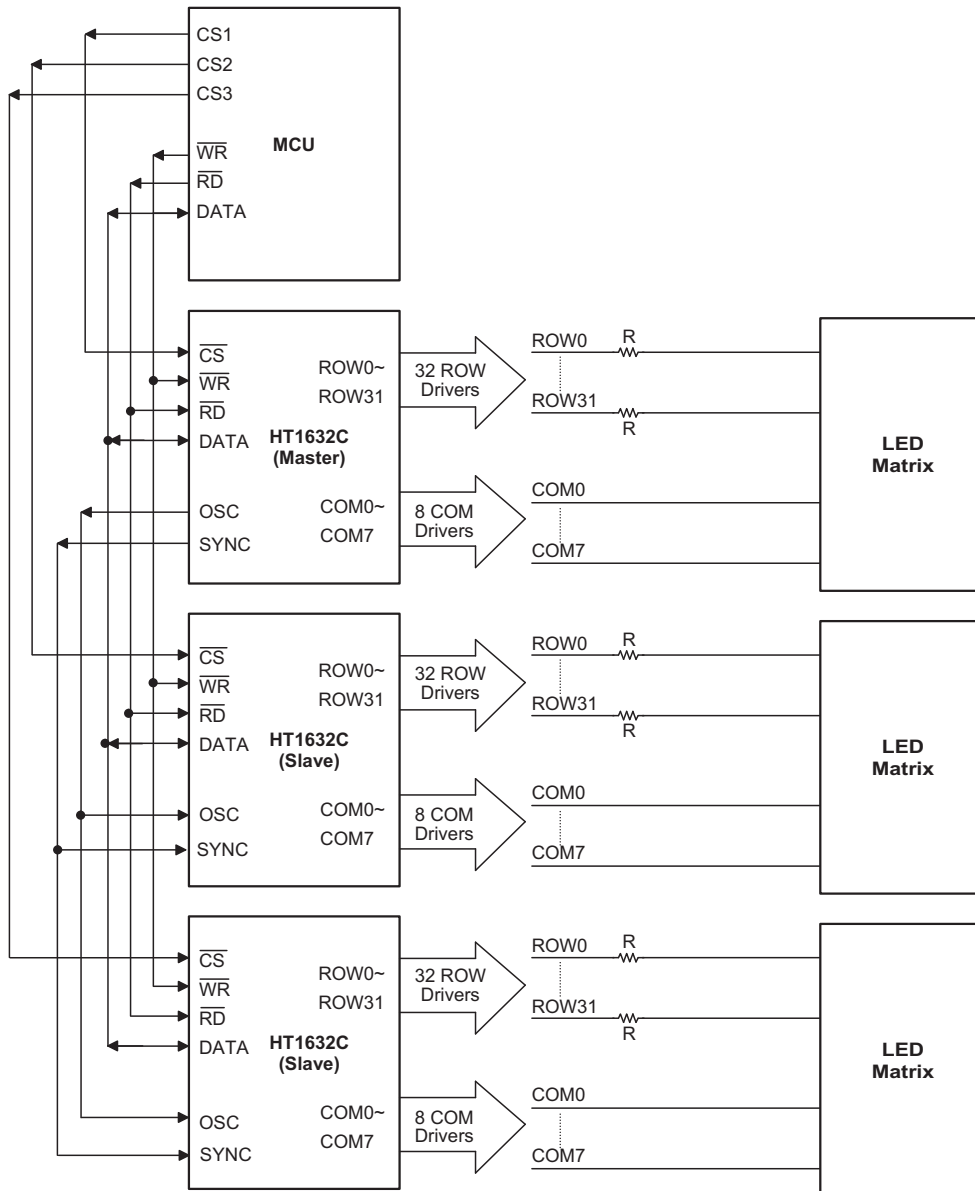

- Note:
1. It also can set cascade mode by software. User must set the Master in master mode and Slaves in slave mode with command. The CS pin must be connected to MCU individually for independent read and write.
  2. Values of the "R" resistors are selected depending on the power consumption of the LEDs.

- 32 ROW × 8 COM example (COM with transistor buffer)

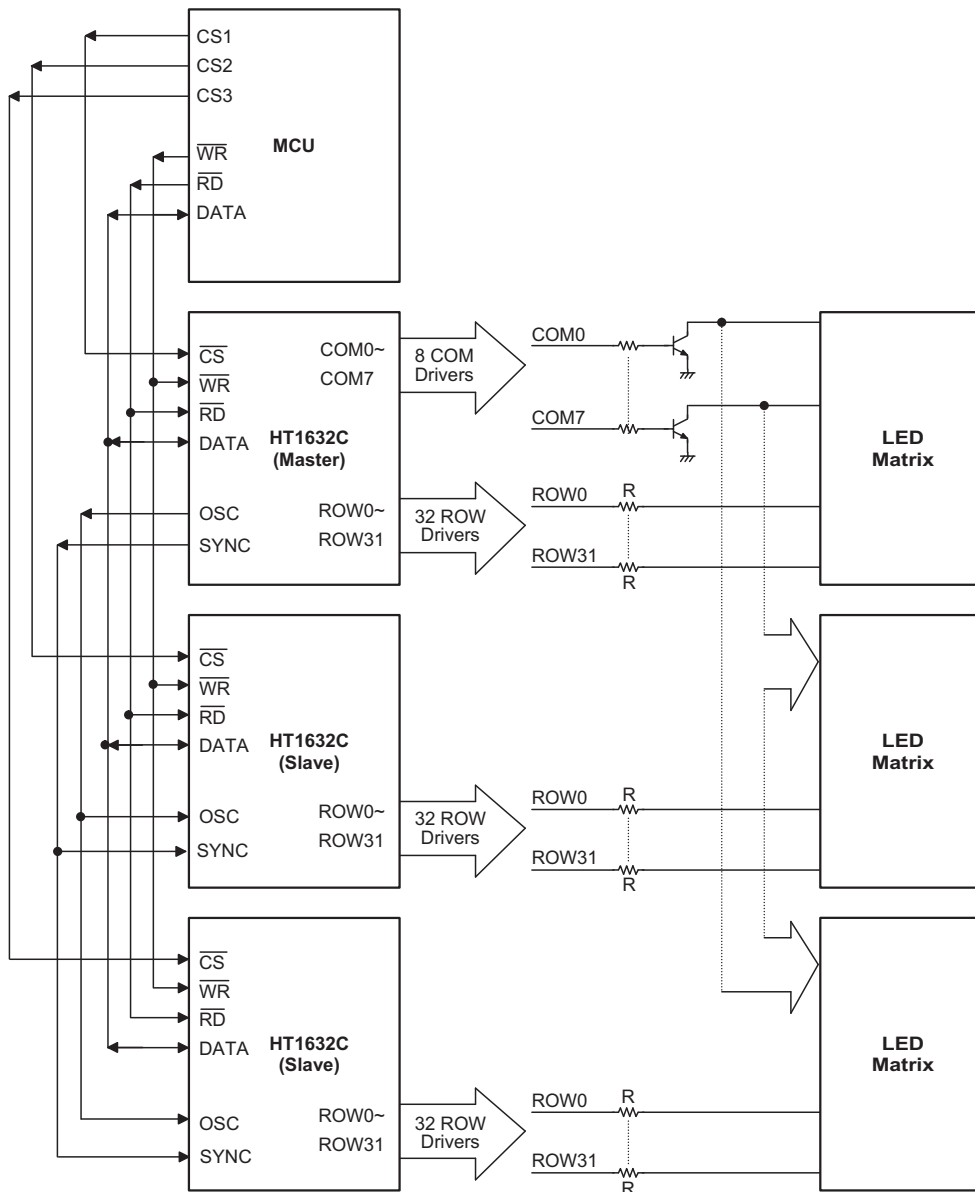

- Note:
1. It also can set cascade mode by software. User must set the Master in master mode and Slaves in slave mode with command. The  $\overline{CS}$  pin must be connected to MCU individually for independent read and write.
  2. Values of the "R" resistors are selected depending on the power consumption of the LEDs.

- 24 ROW × 16 COM example (direct drive)

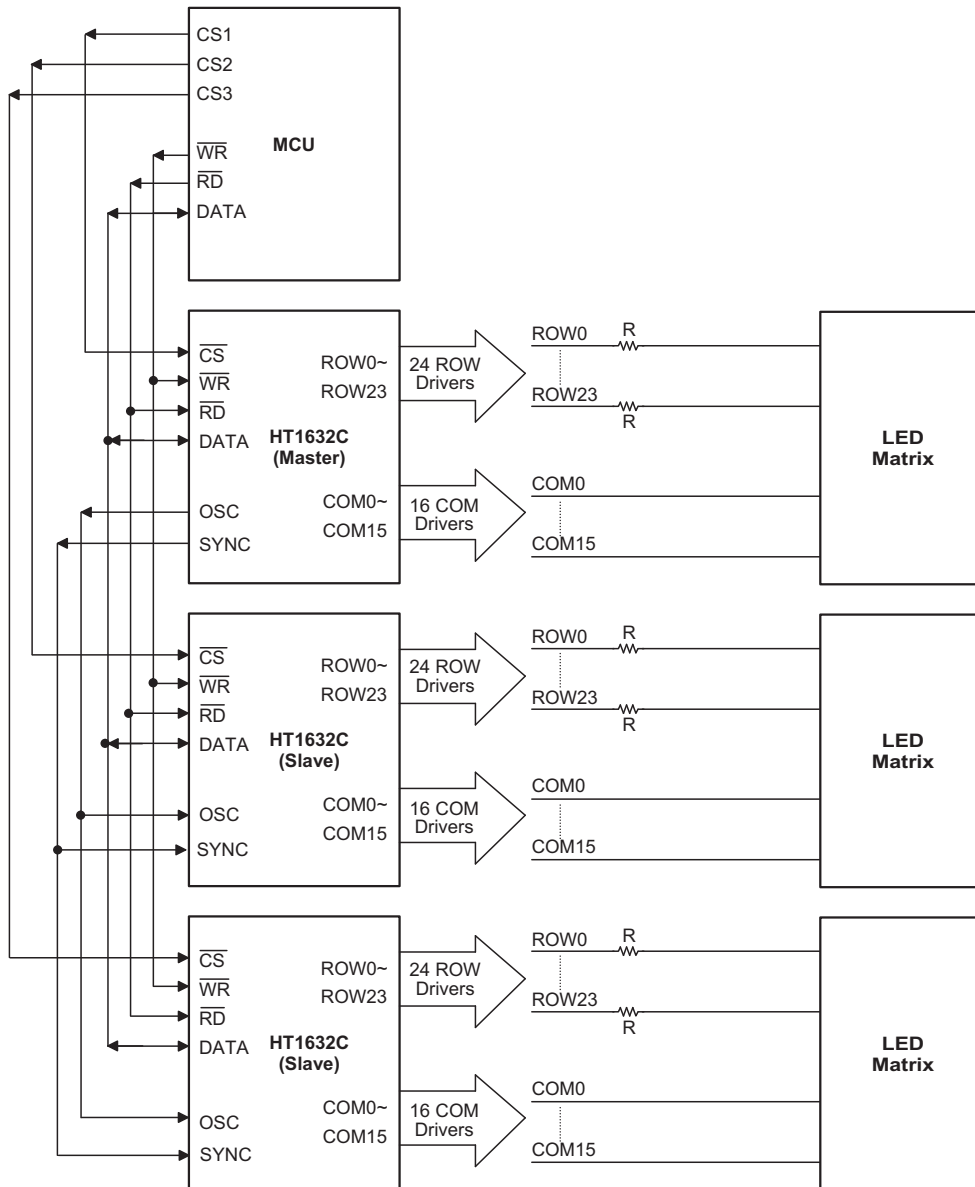

- Note:
1. It also can set cascade mode by software. User must set the Master in master mode and Slaves in slave mode with command. The CS pin must be connected to MCU individually for independent read and write.
  2. Values of the "R" resistors are selected depending on the power consumption of the LEDs.

- 24 ROW × 16 COM example (COM with transistor buffer)

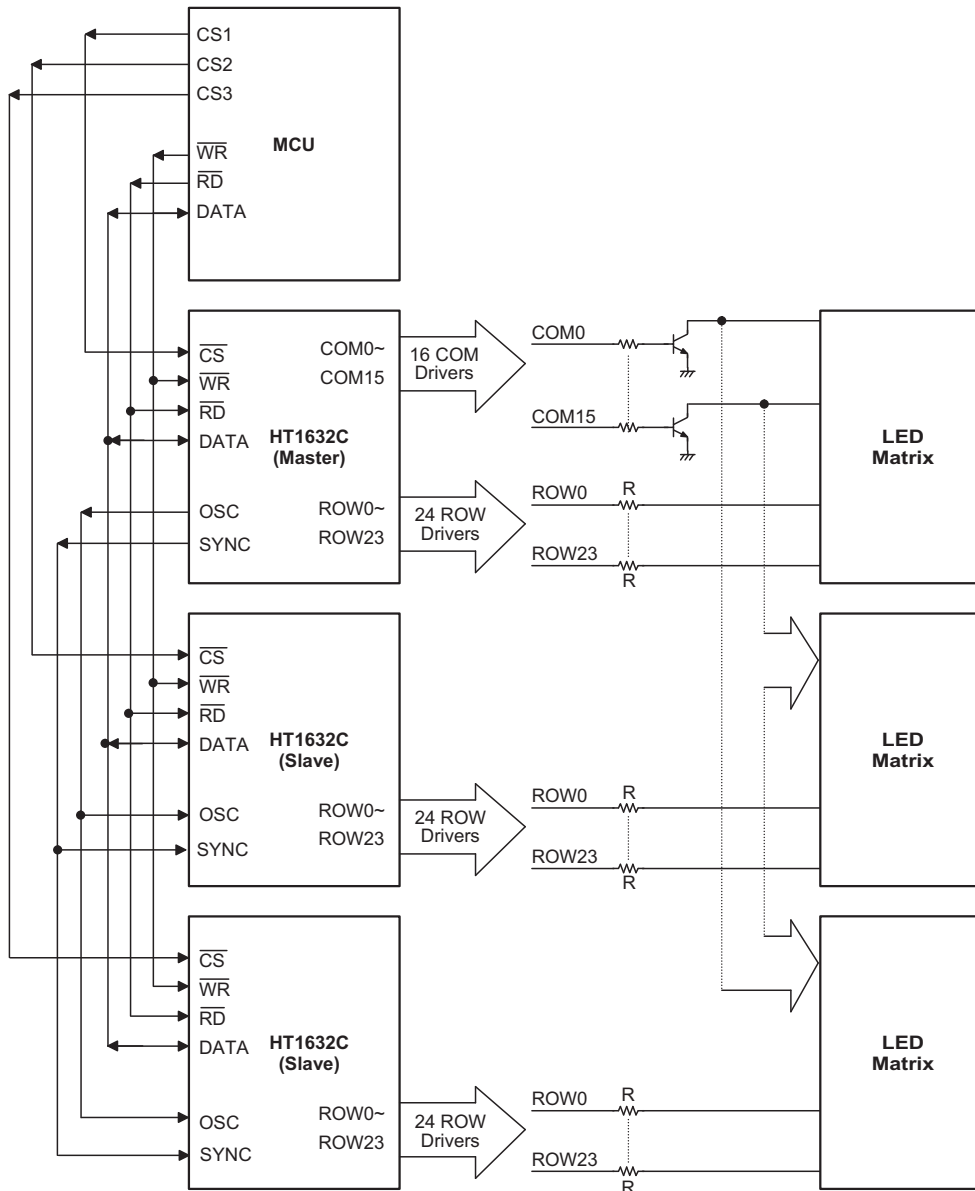

- Note:
1. It also can set cascade mode by software. User must set the Master in master mode and Slaves in slave mode with command. The CS pin must be connected to MCU individually for independent read and write.
  2. Values of the "R" resistors are selected depending on the power consumption of the LEDs.

Cascade Control Flow

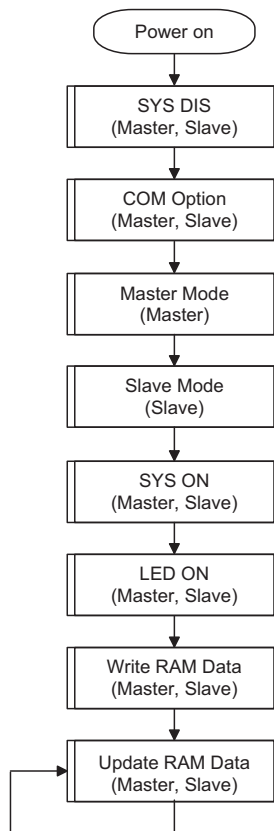

**Command Summary**

Name	ID	Command Code	D/C	Function	Default
READ	1 1 0	A6A5A4A3A2A1A0D0D1D2D3	D	Read data from the RAM	
WRITE	1 0 1	A6A5A4A3A2A1A0D0D1D2D3	D	Write data to the RAM	
READ-MODIFY-WRITE	1 0 1	A6A5A4A3A2A1A0D0D1D2D3	D	Read and Write data to the RAM	
SYS DIS	1 0 0	0000-0000-X	C	Turn off both system oscillator and LED duty cycle generator	Yes
SYS EN	1 0 0	0000-0001-X	C	Turn on system oscillator	
LED Off	1 0 0	0000-0010-X	C	Turn off LED duty cycle generator	Yes
LED On	1 0 0	0000-0011-X	C	Turn on LED duty cycle generator	
BLINK Off	1 0 0	0000-1000-X	C	Turn off blinking function	Yes
BLINK On	1 0 0	0000-1001-X	C	Turn on blinking function	
SLAVE Mode	1 0 0	0001-0XXX-X	C	Set slave mode and clock source from external clock, the system clock input from OSC pin and synchronous signal input from SYN pin	
RC Master Mode	1 0 0	0001-10XX-X	C	Set master mode and clock source from on-chip RC oscillator, the system clock output to OSC pin and synchronous signal output to SYN pin	Yes
EXT CLK Master Mode	1 0 0	0001-11XX-X	C	Set master mode and clock source from external clock, the system clock input from OSC pin and synchronous signal output to SYN pin	
COM Option	1 0 0	0010-abXX-X	C	ab=00: N-MOS open drain output and 8 COM option ab=01: N-MOS open drain output and 16 COM option ab=10: P-MOS open drain output and 8 COM option ab=11: P-MOS open drain output and 16 COM option	ab=00
PWM Duty	1 0 0	101X-0000-X	C	PWM 1/16 duty	
	1 0 0	101X-0001-X	C	PWM 2/16 duty	
	1 0 0	101X-0010-X	C	PWM 3/16 duty	
	1 0 0	101X-0011-X	C	PWM 4/16 duty	
	1 0 0	101X-0100-X	C	PWM 5/16 duty	
	1 0 0	101X-0101-X	C	PWM 6/16 duty	
	1 0 0	101X-0110-X	C	PWM 7/16 duty	
	1 0 0	101X-0111-X	C	PWM 8/16 duty	
	1 0 0	101X-1000-X	C	PWM 9/16 duty	
	1 0 0	101X-1001-X	C	PWM 10/16 duty	
	1 0 0	101X-1010-X	C	PWM 11/16 duty	
	1 0 0	101X-1011-X	C	PWM 12/16 duty	
	1 0 0	101X-1100-X	C	PWM 13/16 duty	
	1 0 0	101X-1101-X	C	PWM 14/16 duty	
	1 0 0	101X-1110-X	C	PWM 15/16 duty	
	1 0 0	101X-1111-X	C	PWM 16/16 duty	Yes

Note: X: Don't care

A6~A0: RAM addresses

D3~D0: RAM data

D/C: Data/command mode

Default: Power on reset default

All the bold forms, namely **1 1 0**, **1 0 1**, and **1 0 0**, are mode commands. Among these, **1 0 0** indicates the command mode ID. If successive commands have been issued, the command mode ID except for the first command will be omitted. The source of the tone frequency and of the time base clock frequency can be derived from an on-chip RC oscillator or an external clock. Calculation of the frequency is based on the system frequency sources as stated above. It is recommended that the host controller should initialize the HT1632C after power on reset, for power on reset may fail, which in turn leads to the malfunction of the HT1632C

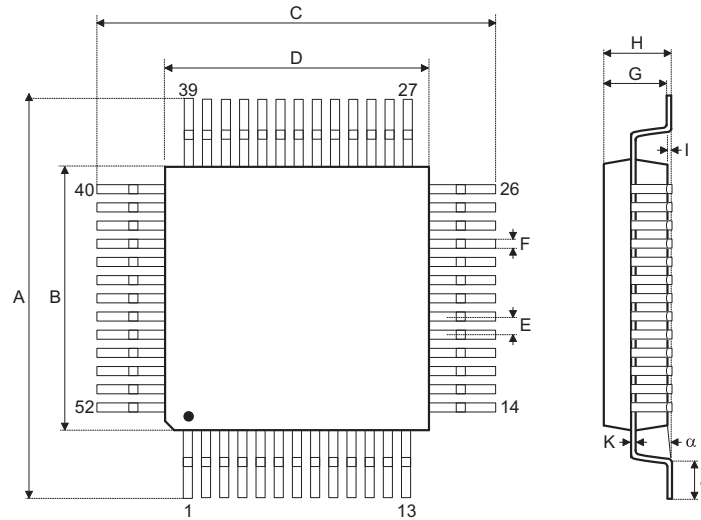
**Package Information**
**52-pin QFP (14mm×14mm) Outline Dimensions**

Symbol	Dimensions in inch		
	Min.	Nom.	Max.
A	0.681	—	0.689
B	0.547	—	0.555
C	0.681	—	0.689
D	0.547	—	0.555
E	—	0.039	—
F	—	0.016	—
G	0.098	—	0.122
H	—	—	0.134
I	—	0.004	—
J	0.029	—	0.041
K	0.004	—	0.008
$\alpha$	0°	—	7°

Symbol	Dimensions in mm		
	Min.	Nom.	Max.
A	17.30	—	17.50
B	13.90	—	14.10
C	17.30	—	17.50
D	13.90	—	14.10
E	—	1.00	—
F	—	0.40	—
G	2.50	—	3.10
H	—	—	3.40
I	—	0.10	—
J	0.73	—	1.03
K	0.10	—	0.20
$\alpha$	0°	—	7°

Copyright © 2011 by HOLTEK SEMICONDUCTOR INC.

The information appearing in this Data Sheet is believed to be accurate at the time of publication. However, Holtek assumes no responsibility arising from the use of the specifications described. The applications mentioned herein are used solely for the purpose of illustration and Holtek makes no warranty or representation that such applications will be suitable without further modification, nor recommends the use of its products for application that may present a risk to human life due to malfunction or otherwise. Holtek's products are not authorized for use as critical components in life support devices or systems. Holtek reserves the right to alter its products without prior notification. For the most up-to-date information, please visit our web site at <http://www.holtek.com.tw>.