

Features

MCU Features

- Operating voltage: 3.0V (typ.)
- Power down and wake-up functions to reduce power consumption
- Five oscillators:
 - External High Speed Xtal
 - External 32.768kHz Xtal
 - External RC
 - Internal High Speed -- no ext. components
 - Internal 32kHz -- no ext. components
- Multi-mode operation: NORMAL, SLOW, IDLE and SLEEP
- Fully integrated internal 4MHz, 8MHz and 12MHz
- All instructions executed in one or two instruction cycles
- Table read instructions
- 63 powerful instructions
- Up to 8 subroutine nesting levels
- Bit manipulation instruction
- Flash Program Memory: 1K×14 ~ 2K×15
- RAM Data Memory: 64×8 ~ 96×8

- EEPROM Memory: 64×8
- Watchdog Timer function
- Up to 8 bidirectional I/O lines
- External interrupt line shared with I/O pin
- Multiple Timer Module for time measure, input capture, compare match output, PWM output or single pulse output functions
- Comparator function
- Dual Time-Base functions for generation of fixed time interrupt signal
- Low voltage reset function
- Low voltage detect function
- Multi-channel 12-bit resolution A/D converter

DC-DC converter Features

- 3.0V ± 2.5% output voltage
- 0.7V start-up voltage
- Output current up to 100mA
- High efficiency: 85% (typ.) at V_{OUT}=3V

General Description

This series of devices are Flash Memory type 8-bit high performance RISC architecture microcontrollers. Offering users the convenience of Flash Memory multi-programming features, these devices also include a wide range of functions and features, among which is their internal DC-DC Converter allowing low voltage operation. In addition to their Flash Program Memory there is also area of RAM Data Memory and an area of EEPROM memory for storage of non-volatile data such as serial numbers, calibration data etc.

Analog features include a multi-channel 12-bit A/D converter and comparator functions. Multiple and extremely flexible Timer Modules provide timing, pulse generation and PWM generation functions. Protective features such as an internal Watchdog Timer, Low Voltage Reset and Low Voltage Detector coupled with excellent noise immunity and ESD protection ensure that reliable operation is maintained in hostile electrical environments.

An extensive choice of oscillator functions is provided including a fully integrated system oscillator which requires no external components for its implementation. The ability to operate and switch dynamically between a range of operating modes using different clock sources gives users the ability to optimise microcontroller operation and minimise power consumption. The devices also include flexible I/O programming features Time-Base functions and a range of other features.

The internal PFM type step-up DC-DC Converter allows the MCU to be powered from low voltage sources, and has the advantages of high efficiency and low ripple. With a fixed and accurate 3.0V output voltage and extremely low 0.7V start-up voltage, these MCU devices will be especially suitable for battery-powered applications, portable handheld equipment etc.

Selection Table

Most features are common to all devices, the main feature distinguishing them are Memory capacity, A/D Converter, Timer Module types and stack capacity. The following table summarises the main features of each device.

Part No.	Program Memory	Data Memory	Data EEPROM	I/O	Ext. Int.	A/D	Timer Module	Comparator	DC-DC Converter	Stack	Package
HT68F03M	1K×14	64×8	64×8	8	1	—	10-bit CTM×1, 10-bit STM×1	1	√	4	16NSOP
HT68F04M	2K×15	96×8	64×8	8	1	—	10-bit CTM×1, 10-bit STM×1	1	√	8	16NSOP
HT66F03M	1K×14	64×8	64×8	8	1	12-bit×4	10-bit CTM×1, 10-bit STM×1	1	√	4	16NSOP
HT66F04M	2K×15	96×8	64×8	8	1	12-bit×4	10-bit CTM×1, 10-bit ETM×1, 10-bit STM×1	1	√	8	16NSOP

Block Diagram

The following block diagram illustrates the dual-chip structure of the devices, where an individual MCU and DC-DC Converter devices are combined into a single package.

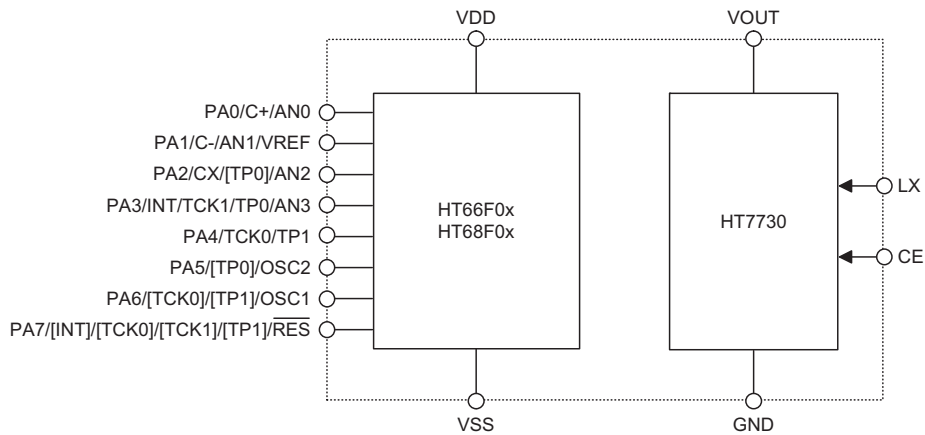

Internal Chip Interconnection Diagram

Note that the HT68F0x devices do not contain VREF or ANx A/D converter pins.

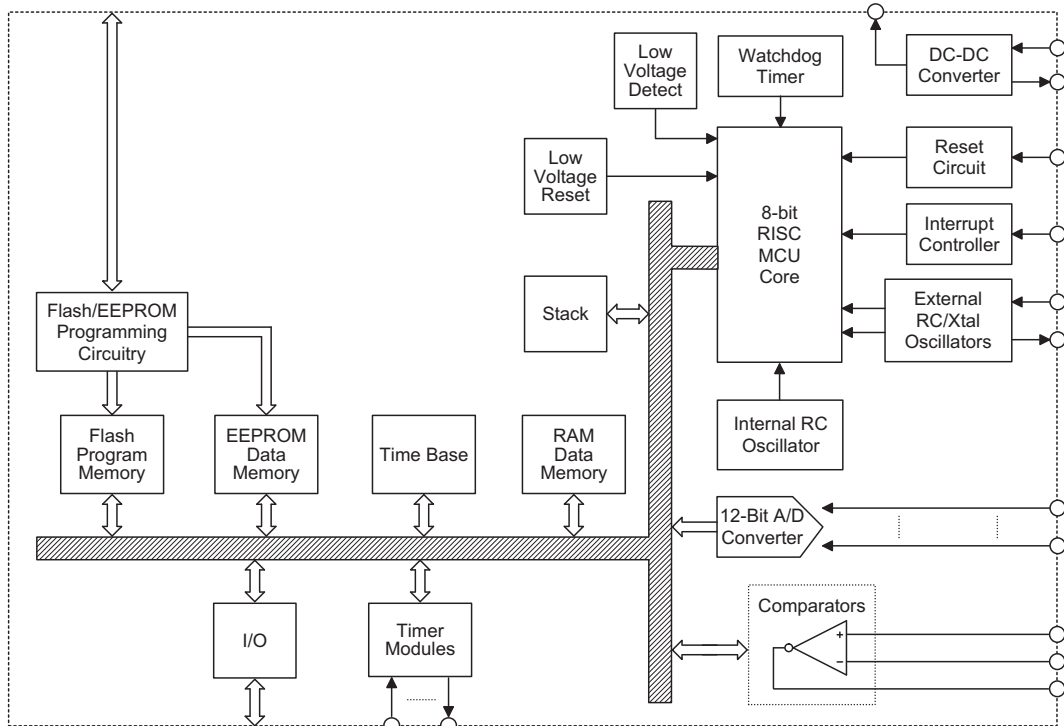

Note that the HT68F0x devices do not contain an A/D converter.

Pin Assignment

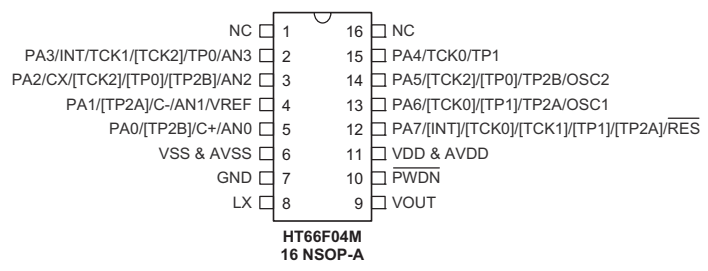
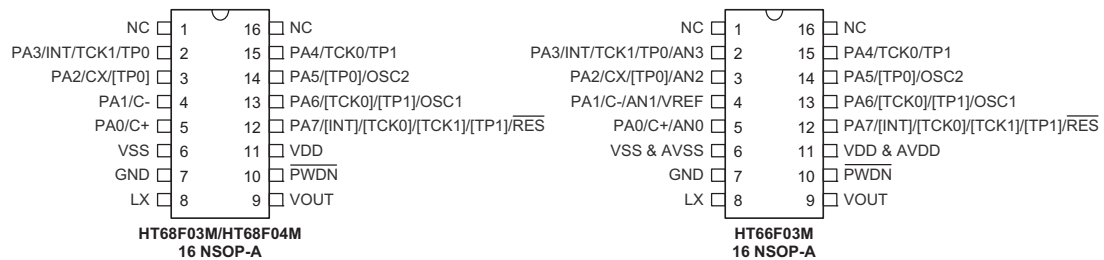

Pin Description
HT68F03M/HT68F04M

Pin Name	Function	OP	I/T	O/T	Pin-Shared Mapping
PA0~PA7	Port A	PAWU PAPU	ST	CMOS	—
C-	Comparator input	CPC CPC	AN	—	PA1
C+	Comparator input		AN	—	PA0
CX	Comparator output		—	CMOS	PA2
TCK0	TM0 input	PRM	ST	—	PA4, PA6 or PA7
TCK1	TM1 input	PRM	ST	—	PA3 or PA7
TP0	TM0 I/O	PRM	ST	CMOS	PA3, PA5 or PA2
TP1	TM1 I/O	PRM	ST	CMOS	PA4, PA6 or PA7
INT	External Interrupt	PRM	ST	—	PA3 or PA7
OSC1	HXT/ERC/LXT pin	CO	HXT/LXT	—	PA6
OSC2	HXT/LXT pin	CO	—	HXT/LXT	PA5
RES	Reset pin	CO	ST	—	PA7
VDD	Power supply	—	PWR	—	—
VSS	Ground	—	PWR	—	—
LX	Switching input pin	—	PWR	—	—
VOUT	DC-DC converter output pin	—	PWR	—	—
CE	DC-DC converter chip enable, active high	—	NS	—	—
GND	Ground	—	PWR	—	—
NC	Not connected	—	—	—	—

Note: I/T: Input type
O/T: Output type
OP: Optional by configuration option (CO) or register option
PWR: Power
CO: Configuration option
ST: Schmitt Trigger input
NS: non-standard input
CMOS: CMOS output
NMOS: NMOS output
SCOM: Software controlled LCD COM
AN: Analog input pin
HXT: High frequency crystal oscillator
LXT: Low frequency crystal oscillator

HT66F03M

Pin Name	Function	OP	I/T	O/T	Pin-Shared Mapping
PA0~PA7	Port A	PAWU PAPU	ST	CMOS	—
AN0~AN3	A/D converter input	ACERL	AN	—	PA0~PA3
VREF	A/D converter reference input	ADCR1	AN	—	PA1
C-	Comparator input	CPC	AN	—	PA1
C+	Comparator input		AN	—	PA0
CX	Comparator output		—	CMOS	PA2
TCK0	TM0 input	PRM	ST	—	PA4, PA6 or PA7
TCK1	TM1 input	PRM	ST	—	PA3 or PA7
TP0	TM0 I/O	PRM	ST	CMOS	PA3, PA5 or PA2
TP1	TM1 I/O	PRM	ST	CMOS	PA4, PA6 or PA7
INT	External interrupt	—	ST	—	PA3 or PA7
OSC1	HXT/ERC/LXT pin	CO	HXT/LXT	—	PA6
OSC2	HXT/LXT pin	CO	—	HXT/LXT	PA5
RES	Reset input	CO	ST	—	PA7
VDD	MCU power supply	—	PWR	—	—
AVDD	A/D converter power supply *	—	PWR	—	—
VSS	MCU ground	—	PWR	—	—
AVSS	A/D converter ground **	—	PWR	—	—
LX	Switching input pin	—	PWR	—	—
VOUT	DC-DC converter output pin	—	PWR	—	—
CE	DC-DC converter chip enable, active high	—	NS	—	—
GND	Ground	—	PWR	—	—
NC	Not connected	—	—	—	—

Note: I/T: Input type

O/T: Output type

OP: Optional by configuration option (CO) or register option

PWR: Power

CO: Configuration option

ST: Schmitt Trigger input

NS: non-standard input

CMOS: CMOS output

NMOS: NMOS output

SCOM: Software controlled LCD COM

AN: Analog input pin

HXT: High frequency crystal oscillator

LXT: Low frequency crystal oscillator

*: VDD is the device power supply while AVDD is the ADC power supply. The AVDD pin is bonded together internally with VDD.

** : VSS is the device ground pin while AVSS is the ADC ground pin. The AVSS pin is bonded together internally with VSS.

HT66F04M

Pin Name	Function	OP	I/T	O/T	Pin-Shared Mapping
PA0~PA7	Port A	PAWU PAPU	ST	CMOS	—
AN0~AN3	A/D converter input	ACERL	AN	—	PA0~PA3
VREF	A/D converter reference input	ADCR1	AN	—	PA1
C-	Comparator input	CPC	AN	—	PA1
C+	Comparator input		AN	—	PA0
CX	Comparator output		—	CMOS	PA2
TCK0	TM0 input	PRM	ST	—	PA4, PA6 or PA7
TCK1	TM1 input	PRM	ST	—	PA3 or PA7
TCK2	TM2 input	PRM	ST	—	PA3, PA5 or PA2
TP0	TM0 I/O	PRM	ST	CMOS	PA3, PA5 or PA2
TP1	TM1 I/O	PRM	ST	CMOS	PA4, PA6 or PA7
TP2A	TM2 I/O	PRM	ST	CMOS	PA6, PA1 or PA7
TP2B	TM2 I/O	PRM	ST	CMOS	PA5, PA0 or PA2
INT	External interrupt	—	ST	—	PA3 or PA7
OSC1	HXT/ERC/LXT pin	CO	HXT/LXT	—	PA6
OSC2	HXT/LXT pin	CO	—	HXT/LXT	PA5
RES	Reset input	CO	ST	—	PA7
VDD	MCU power supply	—	PWR	—	—
AVDD	A/D converter power supply *	—	PWR	—	—
VSS	MCU ground	—	PWR	—	—
AVSS	A/D converter ground **	—	PWR	—	—
LX	Switching input pin	—	PWR	—	—
VOUT	DC-DC converter output pin	—	PWR	—	—
CE	DC-DC converter chip enable, active high	—	NS	—	—
GND	Ground	—	PWR	—	—
NC	Not connected	—	—	—	—

Note: I/T: Input type
O/T: Output type
OP: Optional by configuration option (CO) or register option
PWR: Power
CO: Configuration option
ST: Schmitt Trigger input
NS: non-standard input
CMOS: CMOS output
NMOS: NMOS output
SCOM: Software controlled LCD COM
AN: Analog input pin
HXT: High frequency crystal oscillator
LXT: Low frequency crystal oscillator
*: VDD is the device power supply while AVDD is the ADC power supply. The AVDD pin is bonded together internally with VDD.
**: VSS is the device ground pin while AVSS is the ADC ground pin. The AVSS pin is bonded together internally with VSS.

Functional Description

As these device packages contain multiple internal chips, for a detailed functional description, users must refer to the relevant individual datasheets for both the MCU and the DC-DC Converter. The following table shows which individual devices are inside each package.

Device	MCU	DC-DC Converter
HT68F03M	HT68F03	HT7730
HT68F04M	HT68F04	HT7730
HT66F03M	HT66F03	HT7730
HT66F04M	HT66F04	HT7730

Multi-chip Internal Devices

Although most of the functional description material will be located in the individual datasheets, there are some special considerations which need to be taken into account when using multi-chip devices. These points will be mentioned in the hardware and software consideration sections.

Multi-chip Hardware Considerations

As these single-package multi-chip devices are composed of an individual MCU and DC-DC converter chips, using them together requires the user to take care of some special points.

- **Absolute Maximum Ratings**
The Absolute Maximum Ratings for the two individual chips must be checked for discrepancies and the necessary care taken in device handling and usage.
- **Power Supply**
Examination of the block diagram will reveal that the DC-DC Converter Ground pin, GND, has no internal connection to the MCU Ground pin, VSS. For this reason these two pins must be connected externally. The

DC-DC Converter output pin, VOUT is also not connected to the MCU power supply pin, VDD, so these two pins should also be connected together externally. If the DC-DC Converter is used to power the MCU, then the MCU will always have a power supply of 3V, so care must be taken to only consult the MCU characteristics specified at this power supply voltage. If required, the MCU can be supplied directly on its VDD pin by an external power source if the DC-DC converter is not used.

When calculating the total current consumption of the device, the internal DC specifications of the two internal chips must be consulted and the individual currents added together.

As the MCU power supply may be supplied by the DC-DC Converter it is important to note that if the MCU is powered down or placed into a low power mode to conserve power, that the DC-DC Converter will continue running and will consume a certain amount of power. The DC-DC Converter can of course be powered down by pulling its CE pin low, however as its output voltage falls toward zero, the MCU will experience a reset. The CE pin must therefore be held low for sufficient time to allow the VOUT voltage to fall to a level where the MCU will be properly reset before being powered up again.

Multi-chip Programming Considerations

As there are no internal signal connections between the two internal chips there are no real programming considerations for these devices. It is only necessary to realise that if the MCU is switched into any of its low power modes or executes the HALT instruction by the application program to reduce power consumption, that the DC-DC Converter will continue operating and therefore contribute to the overall power consumption. The DC-DC Converter can only be powered-down manually using its CE pin and if this is done the MCU will be reset.

Application Circuits

HT68F03M/HT68F04M Application Circuit

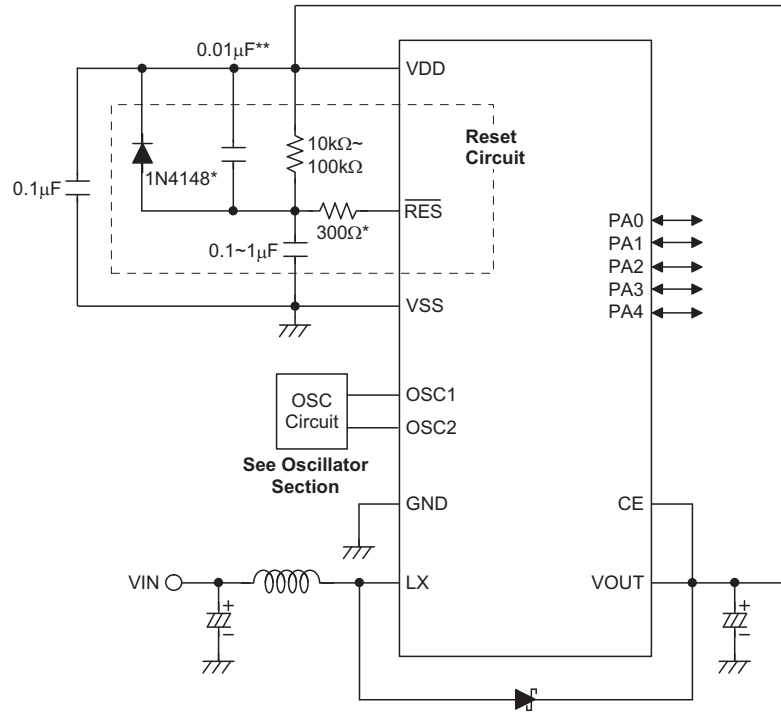

Note: "*" Recommended component for added ESD protection.

**** Recommended component in environments where power line noise is significant.

HT66F03M/HT66F04M Application Circuit

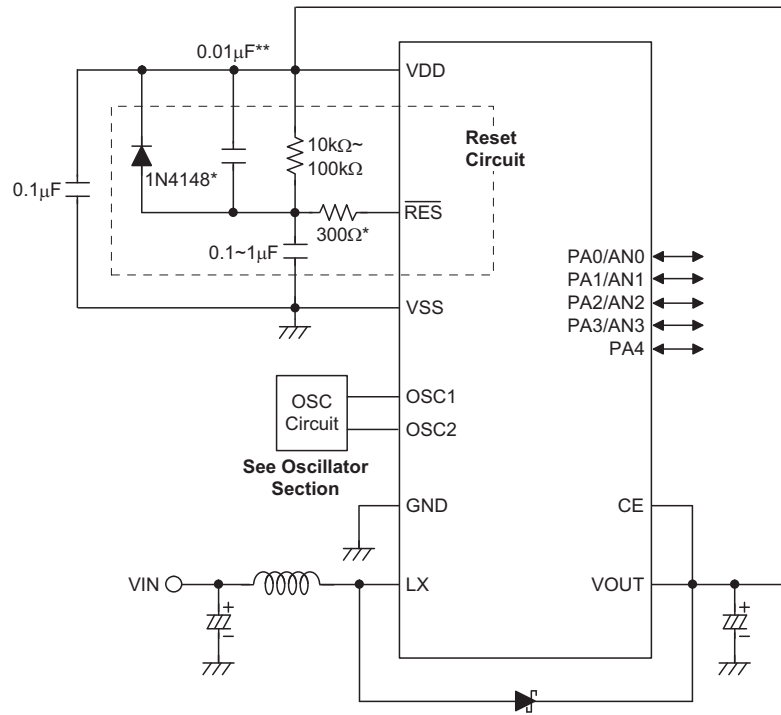

Note: "*" Recommended component for added ESD protection.

**** Recommended component in environments where power line noise is significant.

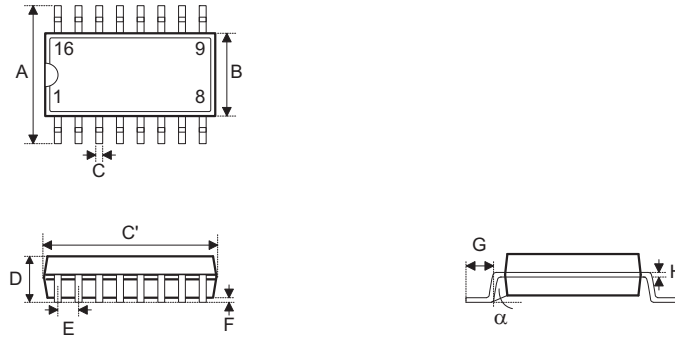
Package Information
16-pin NSOP (150mil) Outline Dimensions

• MS-012

Symbol	Dimensions in inch		
	Min.	Nom.	Max.
A	0.228	—	0.244
B	0.150	—	0.157
C	0.012	—	0.020
C'	0.386	—	0.402
D	—	—	0.069
E	—	0.050	—
F	0.004	—	0.010
G	0.016	—	0.050
H	0.007	—	0.010
α	0°	—	8°

Symbol	Dimensions in mm		
	Min.	Nom.	Max.
A	5.79	—	6.20
B	3.81	—	3.99
C	0.30	—	0.51
C'	9.80	—	10.21
D	—	—	1.75
E	—	1.27	—
F	0.10	—	0.25
G	0.41	—	1.27
H	0.18	—	0.25
α	0°	—	8°

Product Tape and Reel Specifications

Reel Dimensions

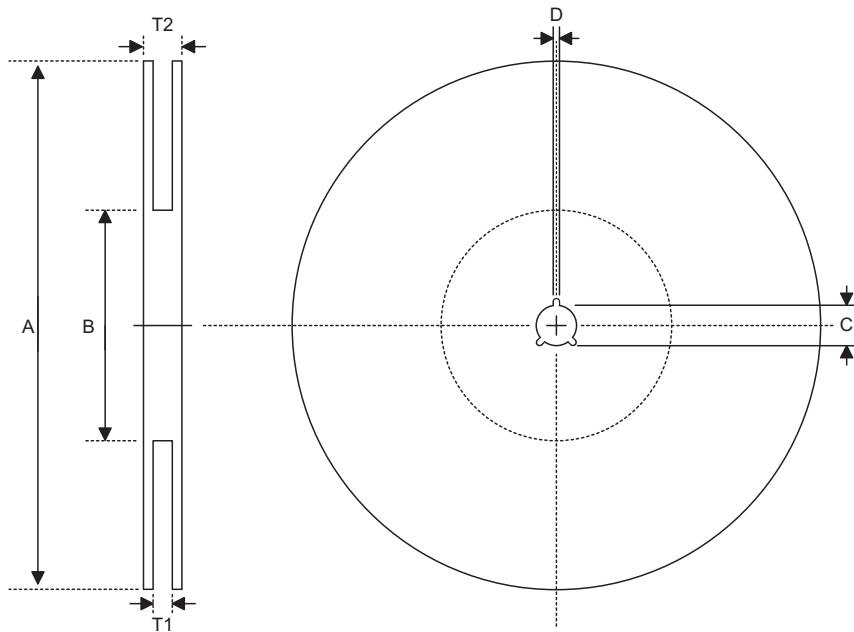

SOP 16N (150mil)

Symbol	Description	Dimensions in mm
A	Reel Outer Diameter	330.0±1.0
B	Reel Inner Diameter	100.0±1.5
C	Spindle Hole Diameter	13.0 ^{+0.5/-0.2}
D	Key Slit Width	2.0±0.5
T1	Space Between Flange	16.8 ^{+0.3/-0.2}
T2	Reel Thickness	22.2±0.2

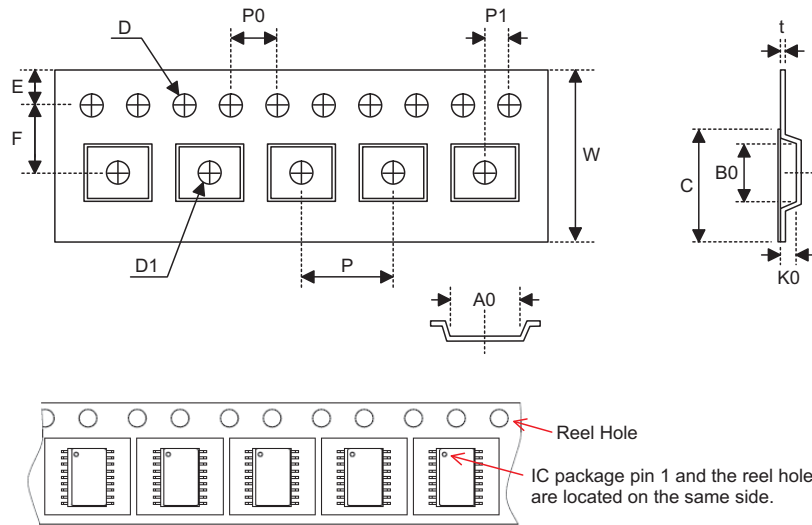
Carrier Tape Dimensions

SOP 16N (150mil)

Symbol	Description	Dimensions in mm
W	Carrier Tape Width	16.0±0.3
P	Cavity Pitch	8.0±0.1
E	Perforation Position	1.75±0.1
F	Cavity to Perforation (Width Direction)	7.5±0.1
D	Perforation Diameter	1.55 ^{+0.10/-0.00}
D1	Cavity Hole Diameter	1.50 ^{+0.25/-0.00}
P0	Perforation Pitch	4.0±0.1
P1	Cavity to Perforation (Length Direction)	2.0±0.1
A0	Cavity Length	6.5±0.1
B0	Cavity Width	10.3±0.1
K0	Cavity Depth	2.1±0.1
t	Carrier Tape Thickness	0.30±0.05
C	Cover Tape Width	13.3±0.1

Holtek Semiconductor Inc. (Headquarters)

No.3, Creation Rd. II, Science Park, Hsinchu, Taiwan
Tel: 886-3-563-1999
Fax: 886-3-563-1189
<http://www.holtek.com.tw>

Holtek Semiconductor Inc. (Taipei Sales Office)

4F-2, No. 3-2, YuanQu St., Nankang Software Park, Taipei 115, Taiwan
Tel: 886-2-2655-7070
Fax: 886-2-2655-7373
Fax: 886-2-2655-7383 (International sales hotline)

Holtek Semiconductor (China) Inc. (Dongguan Sales Office)

Building No. 10, Xinzhu Court, (No. 1 Headquarters), 4 Cuizhu Road, Songshan Lake, Dongguan, China 523808
Tel: 86-769-2626-1300
Fax: 86-769-2626-1311

Holtek Semiconductor (USA), Inc. (North America Sales Office)

46729 Fremont Blvd., Fremont, CA 94538, USA
Tel: 1-510-252-9880
Fax: 1-510-252-9885
<http://www.holtek.com>

Copyright © 2010 by HOLTEK SEMICONDUCTOR INC.

The information appearing in this Data Sheet is believed to be accurate at the time of publication. However, Holtek assumes no responsibility arising from the use of the specifications described. The applications mentioned herein are used solely for the purpose of illustration and Holtek makes no warranty or representation that such applications will be suitable without further modification, nor recommends the use of its products for application that may present a risk to human life due to malfunction or otherwise. Holtek's products are not authorized for use as critical components in life support devices or systems. Holtek reserves the right to alter its products without prior notification. For the most up-to-date information, please visit our web site at <http://www.holtek.com.tw>.