



Enhanced A/D Flash Type MCU

HT66F13/HT66F14/HT66F15

Revision: 1.10 Date: February 9, 2011

www.holtek.com

Table of Contents

Features	6
CPU Features	6
Peripheral Features	6
General Description	7
Selection Table	7
Block Diagram	8
Pin Assignment	9
Pin Description	10
HT66F13	10
HT66F14	11
HT66F15	12
Absolute Maximum Ratings	13
D.C. Characteristics	13
A.C. Characteristics	15
A/D Converter Characteristics	16
Power-on Reset Characteristics	17
System Architecture	18
Clocking and Pipelining	18
Program Counter	19
Stack	19
Arithmetic and Logic Unit – ALU	20
Flash Program Memory	21
Structure	21
Special Vectors	21
Look-up Table	21
Table Program Example	22
In Circuit Programming	23
RAM Data Memory	24
Structure	24
Special Function Register Description	26
Indirect Addressing Registers – IAR0, IAR1	26
Memory Pointers – MP0, MP1	26
Accumulator – ACC	27

Program Counter Low Register – PCL.....	27
Look-up Table Registers – TBLP, TBHP, TBLH.....	27
Status Register – STATUS	27
Oscillator.....	29
Oscillator Overview.....	29
System Clock Configurations.....	29
External Crystal/ Ceramic Oscillator – HXT	30
External RC Oscillator – ERC	31
Internal RC Oscillator – HIRC.....	31
Internal 32kHz Oscillator – LIRC.....	31
Supplementary Oscillator.....	31
Operating Modes and System Clocks	32
System Clocks.....	32
System Operation Modes	32
Control Register	34
Fast Wake-up	35
Operating Mode Switching	36
NORMAL Mode to SLOW Mode Switching.....	37
SLOW Mode to NORMAL Mode Switching.....	38
Entering the SLEEP0 Mode.....	39
Entering the SLEEP1 Mode.....	39
Entering the IDLE0 Mode	39
Entering the IDLE1 Mode	40
Standby Current Considerations.....	40
Wake-up.....	40
Programming Considerations	41
Watchdog Timer	41
Watchdog Timer Clock Source	41
Watchdog Timer Control Register.....	42
Watchdog Timer Operation.....	42
Reset and Initialisation	44
Reset Functions	44
Reset Initial Conditions	47
Input/Output Ports.....	53
I/O Register List.....	53
Pull-high Resistors.....	55
Port A Wake-up	56
I/O Port Control Registers.....	57
I/O Pin Structures	58
Programming Considerations	58

Timer Modules – TM	59
Introduction	59
TM Operation	60
TM Clock Source	60
TM Interrupts	60
TM External Pins	6
TM Input/Output Pin Control Registers	61
Programming Considerations	66
Compact Type TM – CTM	67
Compact TM Operation	67
Compact Type TM Register Description	68
Compact Type TM Operating Modes	72
Standard Type TM – STM	77
Standard TM Operation	77
Standard Type TM Register Description	78
Standard Type TM Operating Modes	82
Enhanced Type TM – ETM	89
Enhanced TM Operation	89
Enhanced Type TM Register Description.....	90
Enhanced Type TM Operating Modes	95
Compare Output Mode	96
Capture Input Mode.....	107
Analog to Digital Converter	109
A/D Overview	109
A/D Converter Register Description	109
A/D Converter Data Registers – ADRL, ADRH	110
A/D Converter Control Registers – ADCR0, ADCR1, ACER	110
A/D Operation.....	113
A/D Input Pins.....	114
Summary of A/D Conversion Steps	115
Programming Considerations	116
A/D Transfer Function	116
A/D Programming Example	117
Interrupts	119
Interrupt Registers	119
Interrupt Operation	124
External Interrupt.....	126
Multi-function Interrupt.....	126
A/D Converter Interrupt.....	127
Time Base Interrupts	127
LVD Interrupt	128
TM Interrupts.....	128

Interrupt Wake-up Function	129
Programming Considerations	129
Power Down Mode and Wake-up	130
Entering the IDLE or SLEEP Mode	130
Standby Current Considerations	130
Wake-up	130
Low Voltage Detector – LVD	131
LVD Register	131
LVD Operation	132
SCOM Function for LCD	132
LCD Operation	132
LCD Bias Control	133
Configuration Options	134
Application Circuits	134
Instruction Set	135
Introduction	135
Instruction Timing	135
Moving and Transferring Data	135
Arithmetic Operations	135
Logical and Rotate Operations	135
Branches and Control Transfer	136
Bit Operations	136
Table Read Operations	136
Other Operations	136
Instruction Set Summary	137
Instruction Definition	139
Package Information	149
16-pin DIP (300mil) Outline Dimensions	149
16-pin NSOP (150mil) Outline Dimensions	152
16-pin SSOP (150mil) Outline Dimensions	153
20-pin DIP (300mil) Outline Dimensions	154
20-pin SOP (300mil) Outline Dimensions	156
20-pin SSOP (150mil) Outline Dimensions	157
24-pin SKDIP (300mil) Outline Dimensions	158
24-pin SOP (300mil) Outline Dimensions	161
24-pin SSOP (150mil) Outline Dimensions	162
28-pin SKDIP (300mil) Outline Dimensions	163
28-pin SOP (300mil) Outline Dimensions	164
28-pin SSOP (150mil) Outline Dimensions	165
Reel Dimensions	166
Carrier Tape Dimensions	168

Features

CPU Features

- Operating Voltage:
f_{sys}= 8MHz: 2.2V~5.5V
f_{sys}= 12MHz: 2.7V~5.5V
f_{sys}= 20MHz: 4.5V~5.5V
- Up to 0.2μs instruction cycle with 20MHz system clock at V_{DD}=5V
- Power down and wake-up functions to reduce power consumption
- Four oscillators:
External Crystal -- HXT
External RC -- ERC
Internal RC -- HIRC
Internal 32kHz RC -- LIRC
- Multi-mode operation: NORMAL, SLOW, IDLE and SLEEP
- Fully integrated internal 4MHz, 8MHz and 12MHz oscillator requires no external components
- All instructions executed in one or two instruction cycles
- Table read instructions
- 63 powerful instructions
- Up to 8-level subroutine nesting
- Bit manipulation instruction

Peripheral Features

- Flash Program Memory: 1K×14 ~ 4K×15
- RAM Data Memory: 64×8 ~ 192×8
- Watchdog Timer function
- Up to 26 bidirectional I/O lines
- Software controlled 4-SCOM lines LCD driver with 1/2 bias
- Multiple pin-shared external interrupts
- Multiple Timer Module for time measure, input capture, compare match output, PWM output or single pulse output function
- Single Time-Base function for generation of fixed time interrupt signal
- 4 channels 12-bit A/D converter
- Low voltage reset function
- Low voltage detect function
- Wide range of available package types

General Description

The HT66F1x series of devices are Flash Memory A/D type 8-bit high performance RISC architecture microcontrollers. Offering users the convenience of Flash Memory multi-programming features, these devices also include a wide range of functions and features. Other memory includes an area of RAM Data Memory for application program data storage.

Analog feature includes a multi-channel 12-bit A/D converter. Multiple and extremely flexible Timer Modules provide timing, pulse generation and PWM generation functions. Protective features such as an internal Watchdog Timer, Low Voltage Reset and Low Voltage Detector coupled with excellent noise immunity and ESD protection ensure that reliable operation is maintained in hostile electrical environments.

A full choice of HXT, ERC, HIRC and LIRC oscillator functions are provided including a fully integrated system oscillator which requires no external components for its implementation. The ability to operate and switch dynamically between a range of operating modes using different clock sources gives users the ability to optimise microcontroller operation and minimise power consumption.

The inclusion of flexible I/O programming features, Time-Base functions along with many other features ensure that the devices will find excellent use in applications such as electronic metering, environmental monitoring, handheld instruments, household appliances, electronically controlled tools, motor driving in addition to many others.

Selection Table

Most features are common to all devices, the main feature distinguishing them are Memory capacity, I/O count, TM features, stack capacity and package types. The following table summarises the main features of each device.

Part No.	VDD	Program Memory	Data Memory	I/O	Ext. Int.	A/D	Timer Module	Stack	Package
HT66F13	2.2V~5.5V	1K×14	64×8	18	2	12-bit×4	10-bit STM×1	4	16DIP/NSOP/SSOP 20DIP/SOP/SSOP
HT66F14	2.2V~5.5V	2K×15	96×8	22	2	12-bit×4	10-bit CTM×1 10-bit STM×1	4	16DIP/NSOP/SSOP 20DIP/SOP/SSOP 24SKDIP/SOP/SSOP
HT66F15	2.2V~5.5V	4K×15	128×8	26	2	12-bit×4	10-bit CTM×1 10-bit ETM×1	8	16DIP/NSOP/SSOP 20DIP/SOP/SSOP 24/28SKDIP/SOP/SSOP

Note: As devices exist in more than one package format, the table reflects the situation for the package with the most pins.

Block Diagram

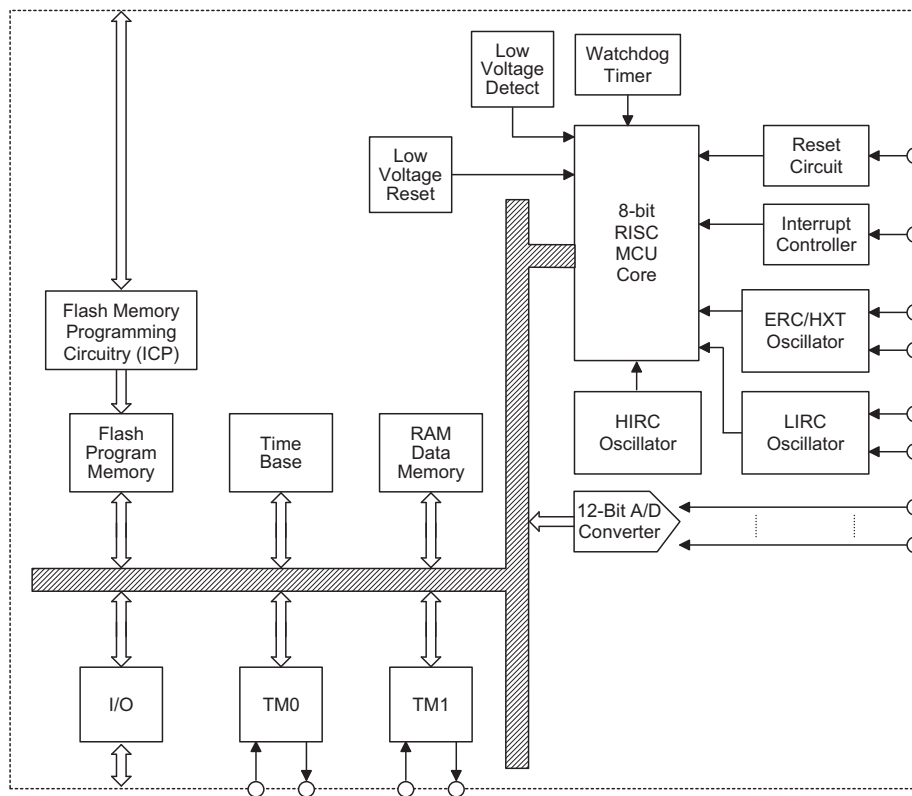

HT66F13/HT66F14/HT66F15

Enhanced A/D Flash Type MCU



Pin Assignment

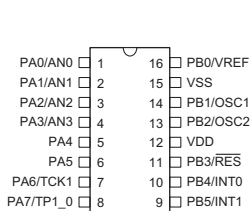

HT66F13
16 DIP-A/NSOP-A/SSOP-A

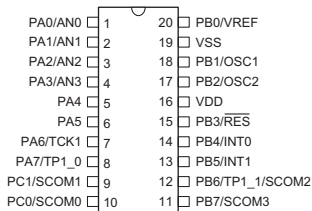

HT66F13
20 DIP-A/SOP-A/SSOP-A

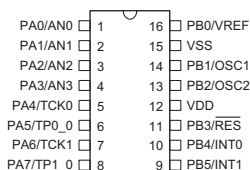

HT66F14
16 DIP-A/NSOP-A/SSOP-A

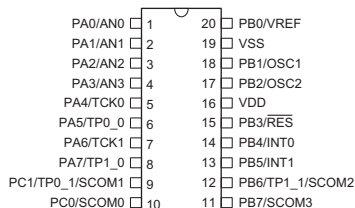

HT66F14
20 DIP-A/SOP-A/SSOP-A

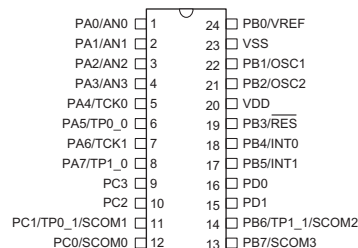

HT66F14
24 SKDIP-A/SOP-A/SSOP-A

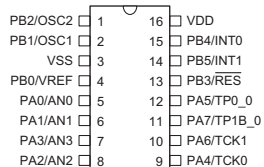

HT66F15
16 DIP-A/NSOP-A/SSOP-A

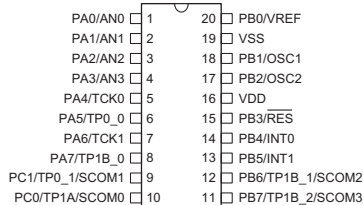

HT66F15
20 DIP-A/SOP-A/SSOP-A

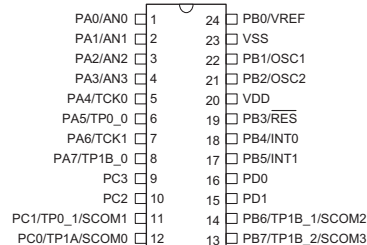

HT66F15
24 SKDIP-A/SOP-A/SSOP-A

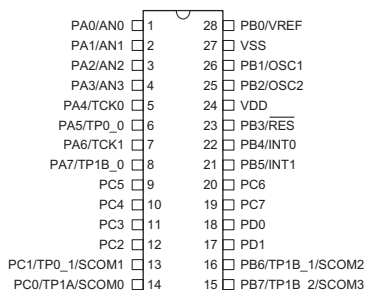

HT66F15
28 SKDIP-A/SOP-A/SSOP-A

Pin Description

With the exception of the power pins, all pins on these devices can be referenced by their Port name, e.g. PA.0, PA.1 etc, which refer to the digital I/O function of the pins. However some of these Port pins are also shared with other function such as the Analog to Digital Converter, Timer Module pins etc. The function of each pin is listed in the following table, however the details behind how each pin is configured is contained in other sections of the datasheet.

HT66F13

Pin Name	Function	OP	I/T	O/T	Pin-Shared Mapping
PA0~PA7	Port A	PAWU PAPU	ST	CMOS	—
PB0~PB7	Port B	PBPU	ST	CMOS	—
PC0~PC1	Port C	PCPU	ST	CMOS	—
AN0~AN3	A/D Converter input	ACER	AN	—	PA0~PA3
VREF	A/D Converter reference input	ADCR1	AN	—	PB0
TCK1	TM1 input	—	ST	—	PA6
TP1_0, TP1_1	TM1 I/O	TMPC	ST	CMOS	PA7, PB6
INT0, INT1	Ext. Interrupt 0, 1	—	ST	—	PB4, PB5
SCOM0~SCOM3	SCOM0~SCOM3	SCOMC	—	SCOM	PC0, PC1, PB6, PB7
OSC1	HXT/ERC pin	CO	HXT	—	PB1
OSC2	HXT pin	CO	—	HXT	PB2
$\overline{\text{RES}}$	Reset pin	CO	ST	—	PB3
VDD	Power supply *	—	PWR	—	—
VSS	Ground *	—	PWR	—	—

Note: I/T: Input type
 O/T: Output type
 OP: Optional by configuration option (CO) or register option
 PWR: Power
 CO: Configuration option
 ST: Schmitt Trigger input
 CMOS: CMOS output
 SCOM: Software controlled LCD COM
 AN: Analog input pin
 HXT: High frequency crystal oscillator
 *: AVDD is the ADC power supply and is bonded together internally with VDD while AVSS is the ADC ground pin and is bonded together internally with VSS.

HT66F13/HT66F14/HT66F15

Enhanced A/D Flash Type MCU



HT66F14

Pin Name	Function	OP	I/T	O/T	Pin-Shared Mapping
PA0~PA7	Port A	PAWU PAPU	ST	CMOS	—
PB0~PB7	Port B	PBPU	ST	CMOS	—
PC0~PC3	Port C	PCPU	ST	CMOS	—
PD0~PD1	Port D	PDPU	ST	CMOS	—
AN0~AN3	A/D converter input	ACER	AN	—	PA0~PA3
VREF	A/D converter reference input	ADCR1	AN	—	PB0
TCK0, TCK1	TM0, TM1 input	—	ST	—	PA4, PA6
TP0_0, TP0_1	TM0 I/O	TMPC	ST	CMOS	PA5, PC1
TP1_0, TP1_1	TM1 I/O	TMPC	ST	CMOS	PA7, PB6
INT0, INT1	Ext. Interrupt 0, 1	—	ST	—	PB4, PB5
SCOM0~SCOM3	SCOM0~SCOM3	SCOMC	—	SCOM	PC0, PC1, PB6, PB7
OSC1	HXT/ERC pin	CO	HXT	—	PB1
OSC2	HXT pin	CO	—	HXT	PB2
RES	Reset pin	CO	ST	—	PB3
VDD	Power supply *	—	PWR	—	—
VSS	Ground *	—	PWR	—	—

Note: I/T: Input type
 I/T: Input type
 O/T: Output type
 OP: Optional by configuration option (CO) or register option
 PWR: Power
 CO: Configuration option
 ST: Schmitt Trigger input
 CMOS: CMOS output
 SCOM: Software controlled LCD COM
 AN: Analog input pin
 HXT: High frequency crystal oscillator
 *: AVDD is the ADC power supply and is bonded together internally with VDD while AVSS is the ADC ground pin and is bonded together internally with VSS.

HT66F15

Pin Name	Function	OP	I/T	O/T	Pin-Shared Mapping
PA0~PA7	Port A	PAWU PAPU	ST	CMOS	—
PB0~PB7	Port B	PBPU	ST	CMOS	—
PC0~PC7	Port C	PCPU	ST	CMOS	—
PD0~PD1	Port D	PDPU	ST	CMOS	—
AN0~AN3	A/D converter input	ACER	AN	—	PA0~PA3
VREF	A/D converter reference input	ADCR1	AN	—	PB0
TCK0, TCK1	TM0, TM1 input	—	ST	—	PA4, PA6
TP0_0, TP0_1	TM0 I/O	TMPC	ST	CMOS	PA5, PC1
TP1A	TM1 I/O	TMPC	ST	CMOS	PC0
TP1B_0, TP1B_1, TP1B_2	TM1 I/O	TMPC	ST	CMOS	PA7, PB6, PB7
INT0, INT1	Ext. Interrupt 0, 1	—	ST	—	PB4, PB5
SCOM0~SCOM3	SCOM0~SCOM3	SCOMC	—	SCOM	PC0, PC1, PB6, PB7
OSC1	HXT/ERC pin	CO	HXT	—	PB1
OSC2	HXT pin	CO	—	HXT	PB2
RES	Reset pin	CO	ST	—	PB3
VDD	Power supply *	—	PWR	—	—
VSS	Ground *	—	PWR	—	—

Note: I/T: Input type
O/T: Output type
OP: Optional by configuration option (CO) or register option
PWR: Power
CO: Configuration option
ST: Schmitt Trigger input
CMOS: CMOS output
SCOM: Software controlled LCD COM
AN: Analog input pin
HXT: High frequency crystal oscillator
*: AVDD is the ADC power supply and is bonded together internally with VDD while AVSS is the ADC ground pin and is bonded together internally with VSS.

Absolute Maximum Ratings

Supply Voltage	$V_{SS}-0.3V$ to $V_{SS}+6.0V$
Input Voltage	$V_{SS}-0.3V$ to $V_{DD}+0.3V$
Storage Temperature	$-50^{\circ}C$ to $125^{\circ}C$
Operating Temperature.....	$-40^{\circ}C$ to $85^{\circ}C$
I_{OL} Total.....	100mA
I_{OH} Total	-100mA
Total Power Dissipation	500mW

Note: These are stress ratings only. Stresses exceeding the range specified under "Absolute Maximum Ratings" may cause substantial damage to the device. Functional operation of this device at other conditions beyond those listed in the specification is not implied and prolonged exposure to extreme conditions may affect device reliability.

D.C. Characteristics

$T_a=25^{\circ}C$

Symbol	Parameter	Test Conditions		Min.	Typ.	Max.	Unit
		V_{DD}	Conditions				
V_{DD}	Operating Voltage (HXT, ERC, HIRC)	—	$f_{SYS}=8MHz$	2.2	—	5.5	V
			$f_{SYS}=12MHz$	2.7	—	5.5	V
			$f_{SYS}=20MHz$	4.5	—	5.5	V
I_{DD1}	Operating Current, Normal Mode, $f_{SYS}=f_H$ (HXT, ERC, HIRC)	3V	No load, $f_{SYS}=f_H=4MHz$, ADC off, WDT enable	—	0.7	1.1	mA
		5V		—	1.8	2.7	mA
		3V	No load, $f_{SYS}=f_H=8MHz$, ADC off, WDT enable	—	1.6	2.4	mA
		5V		—	3.3	5.0	mA
		3V	No load, $f_{SYS}=f_H=12MHz$, ADC off, WDT enable	—	2.2	3.3	mA
		5V		—	5.0	7.5	mA
I_{DD2}	Operating Current, Normal Mode, $f_{SYS}=f_H$ (HXT)	5V	No load, $f_{SYS}=f_H=20MHz$, ADC off, WDT enable	—	6.0	9.0	mA
I_{DD3}	Operating Current, Slow Mode, $f_{SYS}=f_L$ (LIRC)	3V	No load, $f_{SYS}=f_L$, ADC off, WDT enable	—	10	20	μA
		5V		—	30	50	μA
I_{IDLE0}	IDLE0 Mode Standby Current (LIRC on)	3V	No load, ADC off, WDT enable	—	1.5	3.0	μA
		5V		—	3.0	6.0	μA
I_{IDLE1}	IDLE1 Mode Standby Current (HXT, ERC, HIRC)	3V	No load, ADC off, WDT enable, $f_{SYS}=12MHz$ on	—	0.55	0.83	mA
		5V		—	1.30	2.00	mA
I_{SLEEP0}	SLEEP0 Mode Standby Current (LIRC off)	3V	No load, ADC off, WDT disable	—	—	1	μA
		5V		—	—	2	μA
I_{SLEEP1}	SLEEP1 Mode Standby Current (LIRC on)	3V	No load, ADC off, WDT enable	—	1.5	3.0	μA
		5V		—	2.5	5.0	μA
V_{IL1}	Input Low Voltage for I/O Ports or Input Pins except RES pin	—	—	0	—	$0.2V_{DD}$	V
		5V	—	0	—	1.5	V

Symbol	Parameter	Test Conditions		Min.	Typ.	Max.	Unit
		V _{DD}	Conditions				
V _{IH1}	Input High Voltage for I/O Ports or Input Pins except RES pin	—	—	0.8V _{DD}	—	V _{DD}	V
		5V	—	3.5	—	5.0	V
V _{IL2}	Input Low Voltage ($\overline{\text{RES}}$)	—	—	0	—	0.4V _{DD}	V
V _{IH2}	Input High Voltage ($\overline{\text{RES}}$)	—	—	0.9V _{DD}	—	V _{DD}	V
V _{LVR}	LVR Voltage Level	—	LVR Enable, 2.10V option	-5%	2.10	+5%	V
			LVR Enable, 2.55V option	-5%	2.55	+5%	V
			LVR Enable, 3.15V option	-5%	3.15	+5%	V
			LVR Enable, 4.20V option	-5%	4.20	+5%	V
V _{LVD}	LVD Voltage Level	—	LVDEN=1, V _{LVD} =2.0V	-5%	2.00	+5%	V
			LVDEN=1, V _{LVD} =2.2V	-5%	2.20	+5%	V
			LVDEN=1, V _{LVD} =2.4V	-5%	2.40	+5%	V
			LVDEN=1, V _{LVD} =2.7V	-5%	2.70	+5%	V
			LVDEN=1, V _{LVD} =3.0V	-5%	3.00	+5%	V
			LVDEN=1, V _{LVD} =3.3V	-5%	3.30	+5%	V
			LVDEN=1, V _{LVD} =3.6V	-5%	3.60	+5%	V
			LVDEN=1, V _{LVD} =4.4V	-5%	4.40	+5%	V
I _{LV}	Additional Power Consumption if LVR and LVD is Used	—	LVR Enable, LVDEN=0	—	60	90	μA
			LVR disable, LVDEN=1	—	75	115	μA
			LVR enable, LVDEN=1	—	90	135	μA
V _{OL}	Output Low Voltage I/O Port	3V	I _{OL} =9mA	—	—	0.3	V
		5V	I _{OL} =20mA	—	—	0.5	V
V _{OH}	Output High Voltage I/O Port	3V	I _{OH} =-3.2mA	2.7	—	—	V
		5V	I _{OH} =-7.4mA	4.5	—	—	V
R _{PH}	Pull-high Resistance for I/O Ports	3V	—	20	60	100	kΩ
		5V		10	30	50	kΩ
I _{SCOM}	SCOM Operating Current	5V	SCOMC, ISEL[1:0]=00	17.5	25.0	32.5	μA
			SCOMC, ISEL[1:0]=01	35	50	65	μA
			SCOMC, ISEL[1:0]=10	70	100	130	μA
			SCOMC, ISEL[1:0]=11	140	200	260	μA
V _{SCOM}	V _{DD} /2 Voltage for LCD COM	5V	No load	0.475	0.500	0.525	V _{DD}
V ₁₂₅	1.25V Reference with Buffer Voltage	—	—	-3%	1.25	+3%	V
I ₁₂₅	Additional Power Consumption if 1.25V Reference with Buffer is used	—	—	—	200	300	μA

A.C. Characteristics

Ta=25°C

Symbol	Parameter	Test Conditions		Min.	Typ.	Max.	Unit
		V _{DD}	Conditions				
f _{CPU}	Operating Clock	—	2.2V~5.5V	DC	—	8	MHz
			2.7V~5.5V	DC	—	12	MHz
			4.5V~5.5V	DC	—	20	MHz
f _{SYS}	System Clock (HXT)	—	2.2V~5.5V	0.4	—	8	MHz
			2.7V~5.5V	0.4	—	12	MHz
			4.5V~5.5V	0.4	—	20	MHz
f _{HIRC}	System Clock (HIRC)	3V/5V	Ta=25°C	-2%	4	+2%	MHz
		3V/5V	Ta=25°C	-2%	8	+2%	MHz
		5V	Ta=25°C	-2%	12	+2%	MHz
		3V/5V	Ta=0~70°C	-5%	4	+5%	MHz
		3V/5V	Ta=0~70°C	-4%	8	+4%	MHz
		5V	Ta=0~70°C	-5%	12	+3%	MHz
		2.2V~3.6V	Ta=0~70°C	-7%	4	+7%	MHz
		3.0V~5.5V	Ta=0~70°C	-5%	4	+9%	MHz
		2.2V~3.6V	Ta=0~70°C	-6%	8	+4%	MHz
		3.0V~5.5V	Ta=0~70°C	-4%	8	+9%	MHz
		3.0V~5.5V	Ta=0~70°C	-6%	12	+7%	MHz
		2.2V~3.6V	Ta= -40°C~85°C	-12%	4	+8%	MHz
		3.0V~5.5V	Ta= -40°C~85°C	-10%	4	+9%	MHz
		2.2V~3.6V	Ta= -40°C~85°C	-15%	8	+4%	MHz
3.0V~5.5V	Ta= -40°C~85°C	-8%	8	+9%	MHz		
f _{ERC}	System Clock (ERC)	5V	Ta=25°C, R=120kΩ *	-2%	8	+2%	MHz
		5V	Ta=0~70°C, R=120kΩ *	-5%	8	+6%	MHz
		5V	Ta= -40°C~85°C, R=120kΩ *	-7%	8	+9%	MHz
		3.0V~5.5V	Ta= -40°C~85°C, R=120kΩ *	-9%	8	+10%	MHz
		2.2V~5.5V	Ta= -40°C~85°C, R=120kΩ *	-15%	8	+10%	MHz

Symbol	Parameter	Test Conditions		Min.	Typ.	Max.	Unit
		V _{DD}	Conditions				
f _{LIRC}	System Clock (LIRC)	5V	—	-10%	32	+10%	kHz
		2.2V~5.5V	T _a =-40°C~+85°C	-50%	32	+60%	
f _{TIMER}	Timer Input Pin Frequency	—	—	—	—	1	f _{sys}
t _{RES}	External Reset Low Pulse Width	—	—	1	—	—	μs
t _{INT}	Interrupt Pulse Width	—	—	1	—	—	t _{sys}
t _{LVR}	Low Voltage Width to Reset	—	—	120	240	480	μs
t _{LVD}	Low Voltage Width to Interrupt	—	—	20	45	90	μs
t _{LVDS}	LVDO stable time	—	—	15	—	—	μs
t _{BGS}	VBG Turn on Stable Time	—	—	200	—	—	μs
t _{SST}	System Start-up Timer Period (Wake-up from HALT)	—	f _{sys} =HXT	—	1024	—	t _{sys}
			f _{sys} =ERC or HIRC	—	15~16	—	
			f _{sys} =LIRC OSC	—	1~2	—	

- Note:
1. t_{sys}=1/f_{sys}
 2. * For f_{ERC}, as the resistor tolerance will influence the frequency a precision resistor is recommended.
 3. To maintain the accuracy of the internal HIRC oscillator frequency, a 0.1μF decoupling capacitor should be connected between VDD and VSS and located as close to the device as possible.

A/D Converter Characteristics

T_a=25°C

Symbol	Parameter	Test Conditions		Min.	Typ.	Max.	Unit
		V _{DD}	Conditions				
AV _{DD}	A/D Converter Operating Voltage	—	—	2.7	—	5.5	V
V _{ADI}	A/D Converter Input Voltage	—	—	0	—	V _{REF}	V
V _{REF}	A/D Converter Reference Voltage	—	—	2	—	AV _{DD}	V
DNL	Differential Non-linearity	5V	t _{ADCK} = 1.0μs	—	±1	±2	LSB
INL	Integral Non-linearity	5V	t _{ADCK} = 1.0μs	—	±2	±4	LSB
I _{ADC}	Additional Power Consumption if A/D Converter is Used	3V	No load, t _{ADCK} = 0.5μs	—	0.90	1.35	mA
		5V	No load, t _{ADCK} = 0.5μs	—	1.20	1.80	
t _{ADCK}	A/D Converter Clock Period	—	—	0.5	—	10	μs
t _{ADC}	A/D Conversion Time (Include Sample and Hold Time)	—	12-bit A/D Converter	—	16	—	t _{ADCK}
t _{ADS}	A/D Converter Sampling Time	—	—	—	4	—	t _{ADCK}
t _{ON2ST}	A/D Converter On-to-Start Time	—	—	2	—	—	μs

Power-on Reset Characteristics

Ta=25°C

Symbol	Parameter	Test Conditions		Min.	Typ.	Max.	Unit
		V _{DD}	Conditions				
V _{POR}	VDD Start Voltage to Ensure Power-on Reset	—	—	—	—	100	mV
RR _{VDD}	VDD Raising Rate to Ensure Power-on Reset	—	—	0.035	—	—	V/ms
t _{POR}	Minimum Time for VDD Stays at V _{POR} to Ensure Power-on Reset	—	—	1	—	—	ms

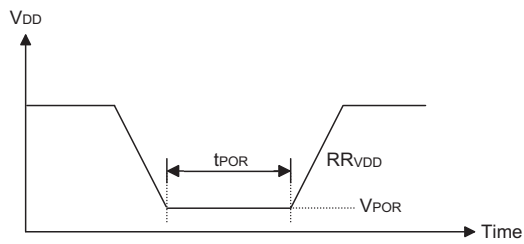

System Architecture

A key factor in the high-performance features of the Holtek range of microcontrollers is attributed to their internal system architecture. The range of devices take advantage of the usual features found within RISC microcontrollers providing increased speed of operation and enhanced performance. The pipelining scheme is implemented in such a way that instruction fetching and instruction execution are overlapped, hence instructions are effectively executed in one cycle, with the exception of branch or call instructions. An 8-bit wide ALU is used in practically all instruction set operations, which carries out arithmetic operations, logic operations, rotation, increment, decrement, branch decisions, etc. The internal data path is simplified by moving data through the Accumulator and the ALU. Certain internal registers are implemented in the Data Memory and can be directly or indirectly addressed. The simple addressing methods of these registers along with additional architectural features ensure that a minimum of external components is required to provide a functional I/O and A/D control system with maximum reliability and flexibility. This makes the device suitable for low-cost, high-volume production for controller applications.

Clocking and Pipelining

The main system clock, derived from either a HXT, ERC, HIRC or LIRC oscillator is subdivided into four internally generated non-overlapping clocks, T1~T4. The Program Counter is incremented at the beginning of the T1 clock during which time a new instruction is fetched. The remaining T2~T4 clocks carry out the decoding and execution functions. In this way, one T1~T4 clock cycle forms one instruction cycle. Although the fetching and execution of instructions takes place in consecutive instruction cycles, the pipelining structure of the microcontroller ensures that instructions are effectively executed in one instruction cycle. The exception to this are instructions where the contents of the Program Counter are changed, such as subroutine calls or jumps, in which case the instruction will take one more instruction cycle to execute.

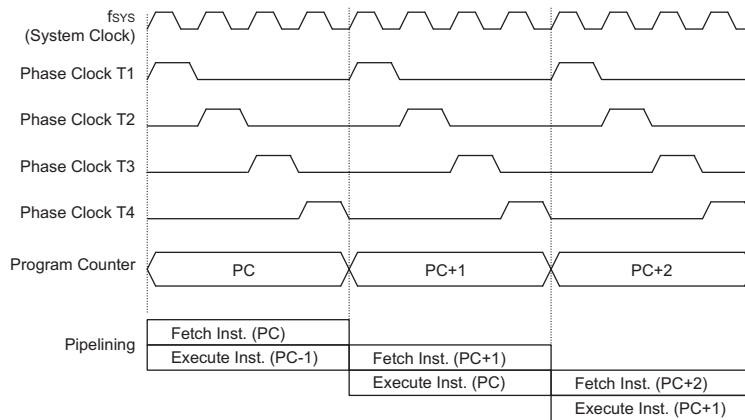

System Clocking and Pipelining

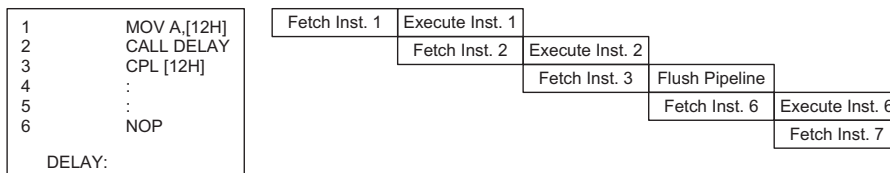

Instruction Fetching

For instructions involving branches, such as jump or call instructions, two machine cycles are required to complete instruction execution. An extra cycle is required as the program takes one cycle to first obtain the actual jump or call address and then another cycle to actually execute the branch. The requirement for this extra cycle should be taken into account by programmers in timing sensitive applications.

Program Counter

During program execution, the Program Counter is used to keep track of the address of the next instruction to be executed. It is automatically incremented by one each time an instruction is executed except for instructions, such as "JMP" or "CALL" that demand a jump to a non-consecutive Program Memory address. Only the lower 8 bits, known as the Program Counter Low Register, are directly addressable by the application program.

When executing instructions requiring jumps to non-consecutive addresses such as a jump instruction, a subroutine call, interrupt or reset, etc., the microcontroller manages program control by loading the required address into the Program Counter. For conditional skip instructions, once the condition has been met, the next instruction, which has already been fetched during the present instruction execution, is discarded and a dummy cycle takes its place while the correct instruction is obtained.

Device	Program Counter	
	Program Counter High Byte	Low Byte (PCL Register)
HT66F13	PC9, PC8	PCL7~PCL0
HT66F14	PC10~PC8	
HT66F15	PC11~PC8	

Program Counter

The lower byte of the Program Counter, known as the Program Counter Low register or PCL, is available for program control and is a readable and writeable register. By transferring data directly into this register, a short program jump can be executed directly, however, as only this low byte is available for manipulation, the jumps are limited to the present page of memory, that is 256 locations. When such program jumps are executed it should also be noted that a dummy cycle will be inserted. Manipulating the PCL register may cause program branching, so an extra cycle is needed to pre-fetch.

Stack

This is a special part of the memory which is used to save the contents of the Program Counter only. The stack has multiple levels depending upon the device and is neither part of the data nor part of the program space, and is neither readable nor writeable. The activated level is indexed by the Stack Pointer, and is neither readable nor writeable. At a subroutine call or interrupt acknowledge signal, the contents of the Program Counter are pushed onto the stack. At the end of a subroutine or an interrupt routine, signaled by a return instruction, RET or RETI, the Program Counter is restored to its previous value from the stack. After a device reset, the Stack Pointer will point to the top of the stack.

If the stack is full and an enabled interrupt takes place, the interrupt request flag will be recorded but the acknowledge signal will be inhibited. When the Stack Pointer is decremented, by RET or RETI, the interrupt will be serviced. This feature prevents stack overflow allowing the programmer to use the structure more easily. However, when the stack is full, a CALL subroutine instruction can still be executed which will result in a stack overflow. Precautions should be taken to avoid such cases which might cause unpredictable program branching.

If the stack is overflow, the first Program Counter save in the stack will be lost.

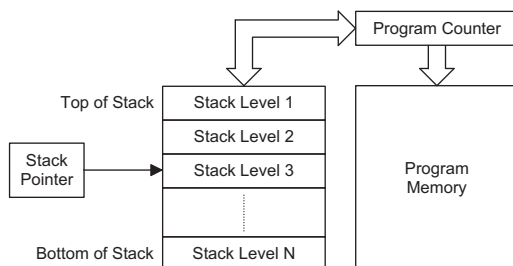

Device	Stack Levels
HT66F13	4
HT66F14	4
HT66F15	8

Arithmetic and Logic Unit – ALU

The arithmetic-logic unit or ALU is a critical area of the microcontroller that carries out arithmetic and logic operations of the instruction set. Connected to the main microcontroller data bus, the ALU receives related instruction codes and performs the required arithmetic or logical operations after which the result will be placed in the specified register. As these ALU calculation or operations may result in carry, borrow or other status changes, the status register will be correspondingly updated to reflect these changes. The ALU supports the following functions:

- Arithmetic operations: ADD, ADDM, ADC, ADCM, SUB, SUBM, SBC, SBCM, DAA
- Logic operations: AND, OR, XOR, , ORM, XORM, CPL, CPLA
- Rotation RRA, RR, RRCA, RRC, RLA, RL, RLCA, RLC
- Increment and Decrement INCA, INC, DECA, DEC
- Branch decision, JMP, SZ, SZA, SNZ, SIZ, SDZ, SIZA, SDZA, CALL, RET, RETI

Flash Program Memory

The Program Memory is the location where the user code or program is stored. For this device series the Program Memory is Flash type, which means it can be programmed and re-programmed a large number of times, allowing the user the convenience of code modification on the same device. By using the appropriate programming tools, these Flash devices offer users the flexibility to conveniently debug and develop their applications while also offering a means of field programming and updating.

Structure

The Program Memory has a capacity of 1K×14 bits to 4K×15 bits. The Program Memory is addressed by the Program Counter and also contains data, table information and interrupt entries. Table data, which can be setup in any location within the Program Memory, is addressed by a separate table pointer register.

Device	Capacity
HT66F13	1K×14
HT66F14	2K×15
HT66F15	4K×15

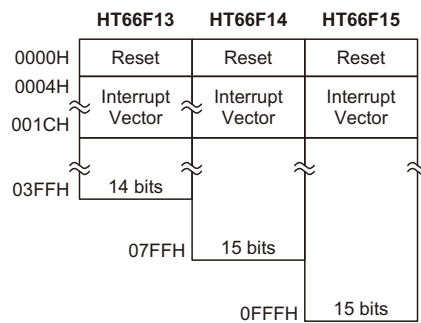

Program Memory Structure

Special Vectors

Within the Program Memory, certain locations are reserved for the reset and interrupts. The location 000H is reserved for use by the device reset for program initialisation. After a device reset is initiated, the program will jump to this location and begin execution.

Look-up Table

Any location within the Program Memory can be defined as a look-up table where programmers can store fixed data. To use the look-up table, the table pointer must first be setup by placing the address of the look up data to be retrieved in the table pointer register, TBLP and TBHP. These registers define the total address of the look-up table.

After setting up the table pointer, the table data can be retrieved from the Program Memory using the "TABRD[m]" or "TABRDL[m]" instructions, respectively. When the instruction is executed, the lower order table byte from the Program Memory will be transferred to the user defined Data Memory register [m] as specified in the instruction. The higher order table data byte from the Program Memory will be transferred to the TBLH special register. Any unused bits in this transferred higher order byte will be read as "0".

The accompanying diagram illustrates the addressing data flow of the look-up table.

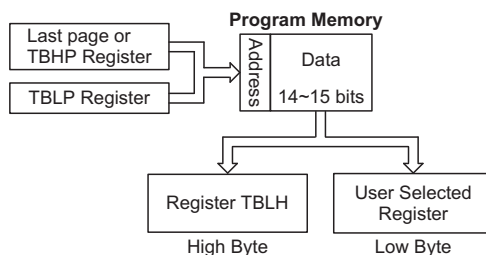

Table Program Example

The following example shows how the table pointer and table data is defined and retrieved from the microcontroller. This example uses raw table data located in the Program Memory which is stored there using the ORG statement. The value at this ORG statement is "700H" which refers to the start address of the last page within the 2K Program Memory of the HT66F14. The table pointer is setup here to have an initial value of "06H". This will ensure that the first data read from the data table will be at the Program Memory address "706H" or 6 locations after the start of the last page. Note that the value for the table pointer is referenced to the first address of the present page if the "TABRD [m]" instruction is being used. The high byte of the table data which in this case is equal to zero will be transferred to the TBLH register automatically when the "TABRD [m]" instruction is executed.

Because the TBLH register is a read-only register and cannot be restored, care should be taken to ensure its protection if both the main routine and Interrupt Service Routine use table read instructions. If using the table read instructions, the Interrupt Service Routines may change the value of the TBLH and subsequently cause errors if used again by the main routine. As a rule it is recommended that simultaneous use of the table read instructions should be avoided. However, in situations where simultaneous use cannot be avoided, the interrupts should be disabled prior to the execution of any main routine table-read instructions. Note that all table related instructions require two instruction cycles to complete their operation.

Table Read Program Example

```

tempreg1    db ?    ; temporary register #1
tempreg2    db ?    ; temporary register #2
:
:
mov    a,06h    ; initialise low table pointer - note that this address
mov    tblp,a  ; is referenced
mov    a,07h    ; initialise high table pointer
mov    tbhp,a
:
:
tabrd tempreg1    ; transfers value in table referenced by table pointer data at
                  ; program memory address "706H" transferred to tempreg1 and TBLH

dec tblp          ; reduce value of table pointer by one
tabrd tempreg2    ; transfers value in table referenced by table pointer data at
                  ; program memory address "705H" transferred to tempreg2 and TBLH
                  ; in this example the data "1AH" is transferred to tempreg1 and
                  ; data "0FH" to register tempreg2
:
:
org 700h          ; sets initial address of program memory

dc 00Ah, 00Bh, 00Ch, 00Dh, 00Eh, 00Fh, 01Ah, 01Bh
:
:

```

In Circuit Programming

The provision of Flash type Program Memory provides the user with a means of convenient and easy upgrades and modifications to their programs on the same device. As an additional convenience, Holtek has provided a means of programming the microcontroller in-circuit using a 5-pin interface. This provides manufacturers with the possibility of manufacturing their circuit boards complete with a programmed or un-programmed microcontroller, and then programming or upgrading the program at a later stage. This enables product manufacturers to easily keep their manufactured products supplied with the latest program releases without removal and re-insertion of the device.

The Holtek Flash MCU to Writer Programming Pin correspondence table is as follows:

Holtek Writer	HT66F13/14/15	Pin Description
Pin Name	Pin Name	
SDATA	PA0	Serial Address and data -- read/write
SCLK	PA2	Address and data serial clock input
VPP	$\overline{\text{RES}}$	Reset input
VDD	VDD	Power Supply (5.0V)
VSS	VSS	Ground

The Program Memory can be programmed serially in-circuit using this 5-wire interface. Data is downloaded and uploaded serially on a single pin with an additional line for the clock. Two additional lines are required for the power supply and one line for the reset. The technical details regarding the in-circuit programming of the devices are beyond the scope of this document and will be supplied in supplementary literature.

During the programming process the $\overline{\text{RES}}$ pin will be held low by the programmer disabling the normal operation of the microcontroller and taking control of the PA0 and PA2 I/O pins for data and clock programming purposes. The user must there take care to ensure that no other outputs are connected to these two pins.

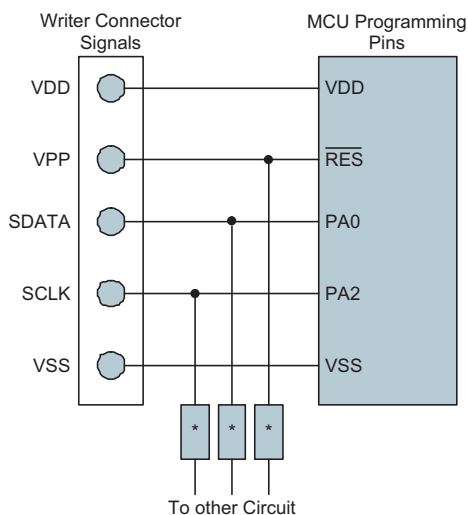

Note: * may be resistor or capacitor. The resistance of * must be greater than 1k Ω or the capacitance of * must be less than 1nF.

RAM Data Memory

The Data Memory is a volatile area of 8-bit wide RAM internal memory and is the location where temporary information is stored.

Structure

Divided into two sections, the first of these is an area of RAM, known as the Special Function Data Memory. Here are located registers which are necessary for correct operation of the device. Many of these registers can be read from and written to directly under program control, however, some remain protected from user manipulation.

The second area of Data Memory is known as the General Purpose Data Memory, which is reserved for general purpose use. All locations within this area are read and write accessible under program control.

Device	Capacity	Address
HT66F13	64×8	40H~7FH
HT66F14	96×8	40H~9FH
HT66F15	192×8	40H~FFH

General Purpose Data Memory Structure

HT66F13		HT66F14		HT66F15	
00H	IAR0	00H	IAR0	00H	IAR0
01H	MP0	01H	MP0	01H	MP0
02H	IAR1	02H	IAR1	02H	IAR1
03H	MP1	03H	MP1	03H	MP1
04H	Unused	04H	Unused	04H	Unused
05H	ACC	05H	ACC	05H	ACC
06H	PCL	06H	PCL	06H	PCL
07H	TBLP	07H	TBLP	07H	TBLP
08H	TBLH	08H	TBLH	08H	TBLH
09H	TBHP	09H	TBHP	09H	TBHP
0AH	STATUS	0AH	STATUS	0AH	STATUS
0BH	SMOD	0BH	SMOD	0BH	SMOD
0CH	LVDC	0CH	LVDC	0CH	LVDC
0DH	INTEG	0DH	INTEG	0DH	INTEG
0EH	WDTC	0EH	WDTC	0EH	WDTC
0FH	TBC	0FH	TBC	0FH	TBC
10H	INTC0	10H	INTC0	10H	INTC0
11H	INTC1	11H	INTC1	11H	INTC1
12H	Unused	12H	Unused	12H	Unused
13H	Unused	13H	Unused	13H	Unused
14H	Unused	14H	MF10	14H	MF10
15H	Unused	15H	MF11	15H	MF11
16H	Unused	16H	Unused	16H	Unused
17H	Unused	17H	Unused	17H	Unused
18H	PAWU	18H	PAWU	18H	PAWU
19H	PAPU	19H	PAPU	19H	PAPU
1AH	PA	1AH	PA	1AH	PA
1BH	PAC	1BH	PAC	1BH	PAC
1CH	PBPU	1CH	PBPU	1CH	PBPU
1DH	PB	1DH	PB	1DH	PB
1EH	PBC	1EH	PBC	1EH	PBC
1FH	PCPU	1FH	PCPU	1FH	PCPU
20H	PC	20H	PC	20H	PC
21H	PCC	21H	PCC	21H	PCC
22H	Unused	22H	PDPU	22H	PDPU
23H	Unused	23H	PD	23H	PD
24H	Unused	24H	PDC	24H	PDC
25H	Unused	25H	Unused	25H	Unused
26H	Unused	26H	Unused	26H	Unused
27H	Unused	27H	Unused	27H	Unused
28H	ADRL	28H	ADRL	28H	ADRL
29H	ADRH	29H	ADRH	29H	ADRH
2AH	ADCR0	2AH	ADCR0	2AH	ADCR0
2BH	ADCR1	2BH	ADCR1	2BH	ADCR1
2CH	ACER	2CH	ACER	2CH	ACER
2DH	TMPC	2DH	TMPC	2DH	TMPC
2EH	Unused	2EH	TM0C0	2EH	TM0C0
2FH	Unused	2FH	TM0C1	2FH	TM0C1
30H	Unused	30H	TM0DL	30H	TM0DL
31H	Unused	31H	TM0DH	31H	TM0DH
32H	Unused	32H	TM0AL	32H	TM0AL
33H	Unused	33H	AM0AH	33H	TM0AH
34H	TM1C0	34H	TM1C0	34H	TM1C0
35H	TM1C1	35H	TM1C1	35H	TM1C1
36H	Unused	36H	Unused	36H	TM1C2
37H	TM1DL	37H	TM1DL	37H	TM1DL
38H	TM1DH	38H	TM1DH	38H	TM1DH
39H	TM1AL	39H	TM1AL	39H	TM1AL
3AH	TM1AH	3AH	TM1AH	3AH	TM1AH
3BH	Unused	3BH	Unused	3BH	TM1BL
3CH	Unused	3CH	Unused	3CH	TM1BH
3DH	SCOMC	3DH	SCOMC	3DH	SCOMC
3EH	Unused	3EH	Unused	3EH	Unused
3FH	Unused	3FH	Unused	3FH	Unused

Special Purpose Data Memory Structure

Special Function Register Description

Most of the Special Function Register details will be described in the relevant functional section. However, several registers require a separate description in this section.

Indirect Addressing Registers – IAR0, IAR1

The Indirect Addressing Registers, IAR0 and IAR1, although having their locations in normal RAM register space, do not actually physically exist as normal registers. The method of indirect addressing for RAM data manipulation uses these Indirect Addressing Registers and Memory Pointers, in contrast to direct memory addressing, where the actual memory address is specified. Actions on the IAR0 and IAR1 registers will result in no actual read or write operation to these registers but rather to the memory location specified by their corresponding Memory Pointers, MP0 or MP1. As the Indirect Addressing Registers are not physically implemented, reading the Indirect Addressing Registers indirectly will return a result of 00H and writing to the registers indirectly will result in no operation.

Indirect Addressing Program Example

```
data .section 'data'
adres1 db ?
adres2 db ?
adres3 db ?
adres4 db ?
block db ?
code .section at 0 'code'
org 00h

start:
    mov     a,04h           ; setup size of block
    mov     block,a
    mov     a,offset adres1 ; Accumulator loaded with first RAM address
    mov     mp0,a          ; setup memory pointer with first RAM address

loop:
    clr     IAR0           ; clear the data at address defined by MP0
    inc     mp0            ; increment memory pointer
    sdz     block          ; check if last memory location has been cleared
    jm     p loop

continue:
```

The important point to note here is that in the example shown above, no reference is made to specific RAM addresses.

Memory Pointers – MP0, MP1

Two Memory Pointers, known as MP0 and MP1 are provided. These Memory Pointers are physically implemented in the Data Memory and can be manipulated in the same way as normal registers providing a convenient way with which to address and track data. When any operation to the relevant Indirect Addressing Registers is carried out, the actual address that the microcontroller is directed to is the address specified by the related Memory Pointer. Note that for the HT66F13 device, bit 7 of the Memory Pointers is not required to address the full memory space. When bit 7 of the Memory Pointers for HT66F13 device is read, a value of 1 will be returned. The following example shows how to clear a section of four Data Memory locations already defined as locations adres1 to adres4.

Accumulator – ACC

The Accumulator is central to the operation of any microcontroller and is closely related with operations carried out by the ALU. The Accumulator is the place where all intermediate results from the ALU are stored. Without the Accumulator it would be necessary to write the result of each calculation or logical operation such as addition, subtraction, shift, etc., to the Data Memory resulting in higher programming and timing overheads. Data transfer operations usually involve the temporary storage function of the Accumulator; for example, when transferring data between one user defined register and another, it is necessary to do this by passing the data through the Accumulator as no direct transfer between two registers is permitted.

Program Counter Low Register – PCL

To provide additional program control functions, the low byte of the Program Counter is made accessible to programmers by locating it within the Special Purpose area of the Data Memory. By manipulating this register, direct jumps to other program locations are easily implemented. Loading a value directly into this PCL register will cause a jump to the specified Program Memory location. However, as the register is only 8-bit wide, only jumps within the current Program Memory page are permitted. When such operations are used, note that a dummy cycle will be inserted.

Look-up Table Registers – TBLP, TBHP, TBLH

These three special function registers are used to control operation of the look-up table which is stored in the Program Memory. TBLP and TBHP are the table pointer and indicates the location where the table data is located. Their value must be setup before any table read commands are executed. Their value can be changed, for example using the "INC" or "DEC" instructions, allowing for easy table data pointing and reading. TBLH is the location where the high order byte of the table data is stored after a table read data instruction has been executed. Note that the lower order table data byte is transferred to a user defined location.

Status Register – STATUS

This 8-bit register contains the zero flag (Z), carry flag (C), auxiliary carry flag (AC), overflow flag (OV), power down flag (PDF), and watchdog time-out flag (TO). These arithmetic/logical operation and system management flags are used to record the status and operation of the microcontroller.

With the exception of the TO and PDF flags, bits in the status register can be altered by instructions like most other registers. Any data written into the status register will not change the TO or PDF flag. In addition, operations related to the status register may give different results due to the different instruction operations. The TO flag can be affected only by a system power-up, a WDT time-out or by executing the "CLR WDT" or "HALT" instruction. The PDF flag is affected only by executing the "HALT" or "CLR WDT" instruction or during a system power-up.

The Z, OV, AC and C flags generally reflect the status of the latest operations.

- **C** is set if an operation results in a carry during an addition operation or if a borrow does not take place during a subtraction operation; otherwise C is cleared. C is also affected by a rotate through carry instruction.
- **AC** is set if an operation results in a carry out of the low nibbles in addition, or no borrow from the high nibble into the low nibble in subtraction; otherwise AC is cleared.
- **Z** is set if the result of an arithmetic or logical operation is zero; otherwise Z is cleared.
- **OV** is set if an operation results in a carry into the highest-order bit but not a carry out of the highest-order bit, or vice versa; otherwise OV is cleared.

- **PDF** is cleared by a system power-up or executing the "CLR WDT" instruction. PDF is set by executing the "HALT" instruction.
- **TO** is cleared by a system power-up or executing the "CLR WDT" or "HALT" instruction. TO is set by a WDT time-out.

In addition, on entering an interrupt sequence or executing a subroutine call, the status register will not be pushed onto the stack automatically. If the contents of the status registers are important and if the subroutine can corrupt the status register, precautions must be taken to correctly save it.

STATUS Register

Bit	7	6	5	4	3	2	1	0
Name	—	—	TO	PDF	OV	Z	AC	C
R/W	—	—	R	R	R/W	R/W	R/W	R/W
POR	—	—	0	0	x	x	x	x

"x" unknown

- Bit 7, 6 Unimplemented, read as "0"
- Bit 5 **TO**: Watchdog Time-Out flag
 0: After power up or executing the "CLR WDT" or "HALT" instruction
 1: A watchdog time-out occurred.
- Bit 4 **PDF**: Power down flag
 0: After power up or executing the "CLR WDT" instruction
 1: By executing the "HALT" instruction
- Bit 3 **OV**: Overflow flag
 0: no overflow
 1: an operation results in a carry into the highest-order bit but not a carry out of the highest-order bit or vice versa.
- Bit 2 **Z**: Zero flag
 0: The result of an arithmetic or logical operation is not zero
 1: The result of an arithmetic or logical operation is zero
- Bit 1 **AC**: Auxiliary flag
 0: no auxiliary carry
 1: an operation results in a carry out of the low nibbles in addition, or no borrow from the high nibble into the low nibble in subtraction
- Bit 0 **C**: Carry flag
 0: no carry-out
 1: an operation results in a carry during an addition operation or if a borrow does not take place during a subtraction operation
C is also affected by a rotate through carry instruction.

Oscillator

Various oscillator options offer the user a wide range of functions according to their various application requirements. The flexible features of the oscillator functions ensure that the best optimisation can be achieved in terms of speed and power saving. Oscillator selections and operation are selected through a combination of configuration options and registers.

Oscillator Overview

In addition to being the source of the main system clock the oscillators also provide clock sources for the Watchdog Timer and Time Base Interrupts. External oscillators requiring some external components as well as fully integrated internal oscillators, requiring no external components, are provided to form a wide range of both fast and slow system oscillators. All oscillator options are selected through the configuration options. The higher frequency oscillators provide higher performance but carry with it the disadvantage of higher power requirements, while the opposite is of course true for the lower frequency oscillators. With the capability of dynamically switching between fast and slow system clock, the device has the flexibility to optimize the performance/ power ratio, a feature especially important in power sensitive portable applications.

Type	Name	Freq.	Pins
External Crystal	HXT	400kHz~20MHz	OSC1/OSC2
External RC	ERC	8MHz	OSC1
Internal High Speed RC	HIRC	4, 8 or 12MHz	—
Internal Low Speed RC	LIRC	32kHz	—

Oscillator Types

System Clock Configurations

There are four system oscillators, three high speed oscillators and one low speed oscillator. The high speed oscillators are the external crystal/ceramic oscillator – HXT, the external – ERC, and the internal RC oscillator – HIRC. The low speed oscillator is the internal 32 kHz oscillator – LIRC. Selecting whether the low or high speed oscillator is used as the system oscillator is implemented using the HLCLK bit and CKS2~CKS0 bits in the SMOD register and as the system clock can be dynamically selected.

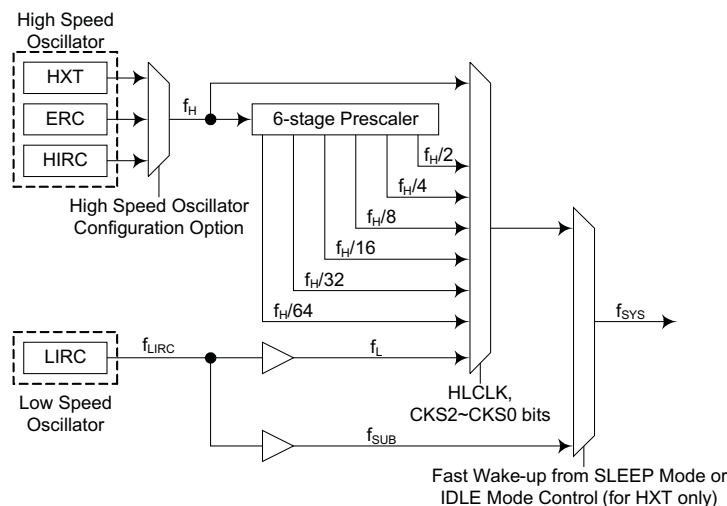

System Clock Configurations

The actual source clock used for each of the high speed and low speed oscillators is chosen via configuration options. The frequency of the slow speed or high speed system clock is also determined using the HLCLK bit and CKS2~CKS0 bits in the SMOD register. Note that two oscillator selections must be made namely one high speed and one low speed system oscillators. It is not possible to choose a no-oscillator selection for either the high or low speed oscillator.

External Crystal/ Ceramic Oscillator – HXT

The External Crystal/Ceramic System Oscillator is one of the high frequency oscillator choices, which is selected via configuration option. For most crystal oscillator configurations, the simple connection of a crystal across OSC1 and OSC2 will create the necessary phase shift and feedback for oscillation, without requiring external capacitors. However, for some crystal types and frequencies, to ensure oscillation, it may be necessary to add two small value capacitors, C1 and C2. Using a ceramic resonator will usually require two small value capacitors, C1 and C2, to be connected as shown for oscillation to occur. The values of C1 and C2 should be selected in consultation with the crystal or resonator manufacturer's specification.

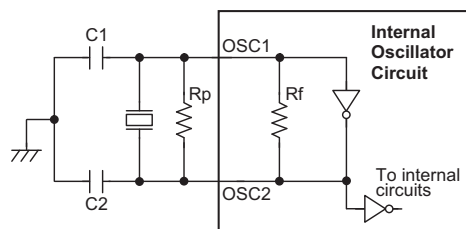

Note: 1. Rp is normally not required. C1 and C2 are required.
 2. Although not shown OSC1/OSC2 pins have a parasitic capacitance of around 7pF.

Crystal/Resonator Oscillator – HXT

Crystal Oscillator C1 and C2 Values		
Crystal Frequency	C1	C2
12MHz	0pF	0pF
8MHz	0pF	0pF
4MHz	0pF	0pF
1MHz	100pF	100pF

Note: C1 and C2 values are for guidance only.

Crystal Recommended Capacitor Values

External RC Oscillator – ERC

Using the ERC oscillator only requires that a resistor, with a value between 24kΩ and 2.4MΩ, is connected between OSC1 and V_{DD}, and a capacitor is connected between OSC1 and ground, providing a low cost oscillator configuration. It is only the external resistor that determines the oscillation frequency; the external capacitor has no influence over the frequency and is connected for stability purposes only. Device trimming during the manufacturing process and the inclusion of internal frequency compensation circuits are used to ensure that the influence of the power supply voltage, temperature and process variations on the oscillation frequency are minimised. As a resistance/frequency reference point, it can be noted that with an external 120kΩ resistor connected and with a 5V voltage power supply and temperature of 25°C degrees, the oscillator will have a frequency of 8MHz within a tolerance of 2%. Here only the OSC1 pin is used, which is shared with I/O pin PB1, leaving pin PB2 free for use as a normal I/O pin.

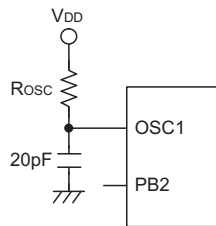

External RC Oscillator – ERC

Internal RC Oscillator – HIRC

The internal RC oscillator is a fully integrated system oscillator requiring no external components. The internal RC oscillator has three fixed frequencies of either 4MHz, 8MHz or 12MHz. Device trimming during the manufacturing process and the inclusion of internal frequency compensation circuits are used to ensure that the influence of the power supply voltage, temperature and process variations on the oscillation frequency are minimised. As a result, at a power supply of either 3V or 5V and at a temperature of 25°C degrees, the fixed oscillation frequency of 4MHz, 8MHz or 12MHz will have a tolerance within 2%. Note that if this internal system clock option is selected, as it requires no external pins for its operation, I/O pins PB1 and PB2 are free for use as normal I/O pins.

Internal 32kHz Oscillator – LIRC

The Internal 32kHz System Oscillator is one of the low frequency oscillator choices, which is selected via configuration option. It is a fully integrated RC oscillator with a typical frequency of 32kHz at 5V, requiring no external components for its implementation. Device trimming during the manufacturing process and the inclusion of internal frequency compensation circuits are used to ensure that the influence of the power supply voltage, temperature and process variations on the oscillation frequency are minimised. As a result, at a power supply of 5V and at a temperature of 25°C degrees, the fixed oscillation frequency of 32kHz will have a tolerance within 10%.

Supplementary Oscillator

The low speed oscillator, in addition to providing a system clock source, is also used to provide a clock source to two other device functions. These are the Watchdog Timer and the Time Base Interrupts.

Operating Modes and System Clocks

Present day applications require that their microcontrollers have high performance but often still demand that they consume as little power as possible, conflicting requirements that are especially true in battery powered portable applications. The fast clocks required for high performance will by their nature increase current consumption and of course vice versa, lower speed clocks reduce current consumption. As Holtek has provided these devices with both high and low speed clock sources and the means to switch between them dynamically, the user can optimise the operation of their microcontroller to achieve the best performance/power ratio.

System Clocks

The device has many different clock sources for both the CPU and peripheral function operation. By providing the user with a wide range of clock options using configuration options and register programming, a clock system can be configured to obtain maximum application performance.

The main system clock can come from a high frequency f_H or low frequency f_L source and is selected using the HLCLK bit and CKS2~CKS0 bits in the SMOD register. The high speed system clock can be sourced from either a HXT, ERC or HIRC oscillator, selected via a configuration option. The low speed system clock source can be sourced from internal clock f_L . If f_L is selected, then it can be sourced by the LIRC oscillator. The other choice, which is a divided version of the high speed system oscillator has a range of $f_H/2 \sim f_H/64$. Note that when the system clock source f_{SYS} is switched to f_L from f_H , the high speed oscillation will stop to conserve the power. Thus there is no $f_H \sim f_H/64$ for peripheral circuit to use.

There are two additional internal clocks for the peripheral circuits, the substitute clock, f_{SUB} , and the Time Base clock, f_{TBC} . These internal clocks are sourced by the LIRC oscillator. The f_{SUB} clock is used to provide a substitute clock for the microcontroller just after a wake-up has occurred to enable faster wake-up times. Together with $f_{SYS}/4$ it is also used as one of the clock sources for the Watchdog timer. The f_{TBC} clock is used as a source for the Time Base interrupt functions and for the TMs.

System Operation Modes

There are six different modes of operation for the microcontroller, each one with its own special characteristics and which can be chosen according to the specific performance and power requirements of the application. There are two modes allowing normal operation of the microcontroller, the NORMAL Mode and SLOW Mode. The remaining four modes, the SLEEP0, SLEEP1, IDLE0 and IDLE1 Mode are used when the microcontroller CPU is switched off to conserve power.

Operation Mode	Description				
	CPU	f_{SYS}	f_{SUB}	f_S	f_{TBC}
NORMAL Mode	On	$f_H \sim f_H/64$	On	On	On
SLOW Mode	On	f_L	On	On	On
IDLE0 Mode	On	Off	On	On/Off	On
IDLE1 Mode	Off	On	On	On	On
SLEEP0 Mode	Off	Off	Off	Off	Off
SLEEP1 Mode	Off	Off	On	On	Off

NORMAL Mode

As the name suggests this is one of the main operating modes where the microcontroller has all of its functions operational and where the system clock is provided by one of the high speed oscillators. This mode operates allowing the microcontroller to operate normally with a clock source will come from one of the high speed oscillators, either the HXT, ERC or HIRC oscillators. The high speed oscillator will however first be divided by a ratio ranging from 1 to 64, the actual ratio being selected by the CKS2~CKS0 and HLCLK bits in the SMOD register. Although a high speed oscillator is used, running the microcontroller at a divided clock ratio reduces the operating current.

SLOW Mode

This is also a mode where the microcontroller operates normally although now with a slower speed clock source. The clock source used will be from the low speed oscillator LIRC. Running the microcontroller in this mode allows it to run with much lower operating currents. In the SLOW Mode, the f_H is off.

SLEEP0 Mode

The SLEEP Mode is entered when an HALT instruction is executed and when the IDLEN bit in the SMOD register is low. In the SLEEP0 mode the CPU will be stopped, and the f_{SUB} and f_S clocks will be stopped too, and the Watchdog Timer function is disabled. In this mode, the LVDEN is must set to "0". If the LVDEN is set to "1", it won't enter the SLEEP0 Mode.

SLEEP1 Mode

The SLEEP Mode is entered when a HALT instruction is executed and the IDLEN bit in the SMOD register is low. In the SLEEP1 mode the CPU will be stopped. However, the f_{SUB} and f_S clocks will continue to operate if the LVDEN is set to "1" or the Watchdog Timer function is enabled and if its clock source is chosen via configuration option to come from the f_{SUB} .

IDLE0 Mode

The IDLE0 Mode is entered when a HALT instruction is executed and when the IDLEN bit in the SMOD register is high and the FSYSOEN bit in the WDTC register is low. In the IDLE0 Mode the system oscillator will be inhibited from driving the CPU but some peripheral functions will remain operational such as the Watchdog Timer and TMs. In the IDLE0 Mode, the system oscillator will be stopped. In the IDLE0 Mode the Watchdog Timer clock, f_S , will either be on or off depending upon the f_S clock source. If the source is $f_{SYS}/4$, then the f_S clock will be off, and if the source comes from f_{SUB} then f_S will be on.

IDLE1 Mode

The IDLE1 Mode is entered when a HALT instruction is executed and when the IDLEN bit in the SMOD register is high and the FSYSOEN bit in the WDTC register is high. In the IDLE1 Mode the system oscillator will be inhibited from driving the CPU but may continue to provide a clock source to keep some peripheral functions operational such as the Watchdog Timer and TMs. In the IDLE1 Mode, the system oscillator will continue to run, and this system oscillator may be high speed or low speed system oscillator. In the IDLE1 Mode the Watchdog Timer clock, f_S , will be on. If the source is $f_{SYS}/4$, then the f_S clock will be on, and if the source comes from f_{SUB} then f_S will be on.

Control Register

A single register, SMOD, is used for overall control of the internal clocks within the device.

SMOD Register

Bit	7	6	5	4	3	2	1	0
Name	CKS2	CKS1	CKS0	FSTEN	LTO	HTO	IDLEN	HLCLK
R/W	R/W	R/W	R/W	R/W	R	R	R/W	R/W
POR	0	0	0	0	0	0	1	1

- Bit 7~5** **CKS2~CKS0:** The system clock selection when HLCLK is "0"
 000: f_L (f_{LIRC})
 001: f_L (f_{LIRC})
 010: $f_H/64$
 011: $f_H/32$
 100: $f_H/16$
 101: $f_H/8$
 110: $f_H/4$
 111: $f_H/2$
 These three bits are used to select which clock is used as the system clock source. In addition to the system clock source, which is the LIRC, a divided version of the high speed system oscillator can also be chosen as the system clock source.
- Bit 4** **FSTEN:** Fast Wake-up Control (only for HXT)
 0: Disable
 1: Enable
 This is the Fast Wake-up Control bit which determines if the f_{SUB} clock source is initially used after the device wakes up. When the bit is high, the f_{SUB} clock source can be used as a temporary system clock to provide a faster wake up time as the f_{SUB} clock is available.
- Bit 3** **LTO:** Low speed system oscillator ready flag
 0: Not ready
 1: Ready
 This is the low speed system oscillator ready flag which indicates when the low speed system oscillator is stable after power on reset or a wake-up has occurred. The flag will be low when in the SLEEP0 Mode but after a wake-up has occurred, the flag will change to a high level after 1~2 clock cycles as the LIRC oscillator is used.
- Bit 2** **HTO:** High speed system oscillator ready flag
 0: Not ready
 1: Ready
 This is the high speed system oscillator ready flag which indicates when the high speed system oscillator is stable. This flag is cleared to "0" by hardware when the device is powered on and then changes to a high level after the high speed system oscillator is stable. Therefore this flag will always be read as "1" by the application program after device power-on. The flag will be low when in the SLEEP or IDLE0 Mode but after a wake-up has occurred, the flag will change to a high level after 1024 clock cycles if the HXT oscillator is used and after 15~16 clock cycles if the ERC or HIRC oscillator is used.
- Bit 1** **IDLEN:** IDLE Mode control
 0: Disable
 1: Enable
 This is the IDLE Mode Control bit and determines what happens when the HALT instruction is executed. If this bit is high, when a HALT instruction is executed the device will enter the IDLE Mode. In the IDLE1 Mode the CPU will stop running but the system clock will continue to keep the peripheral functions operational as the FSYSON bit is high. If FSYSON bit is low, the CPU and the system clock will all stop in IDLE0 mode. If the bit is low the device will enter the SLEEP Mode when a HALT instruction is executed.

Bit 0 **HLCLK**: system clock selection
 0: $f_{H}/2 \sim f_{H}/64$ or f_L
 1: f_H

This bit is used to select if the f_H clock or the $f_{H}/2 \sim f_{H}/64$ or f_L clock is used as the system clock. When the bit is high the f_H clock will be selected and if low the $f_{H}/2 \sim f_{H}/64$ or f_L clock will be selected. When system clock switches from the f_H clock to the f_L clock, the f_H clock will be automatically switched off to conserve power.

Fast Wake-up

To minimise power consumption the device can enter the SLEEP or IDLE0 Mode, where the system clock source to the device will be stopped. However when the device is woken up again, it can take a considerable time for the original system oscillator to restart, stabilise and allow normal operation to resume. To ensure the device is up and running as fast as possible a Fast Wake-up function is provided, which allows f_{SUB} , namely the LIRC oscillator, to act as a temporary clock to first drive the system until the original system oscillator has stabilised. As the clock source for the Fast Wake-up function is f_{SUB} , the Fast Wake-up function is only available in the SLEEP1 and IDLE0 modes. When the device is woken up from the SLEEP0 mode, the Fast Wake-up function has no effect because the f_{SUB} clock is stopped. The Fast Wake-up enable/disable function is controlled using the FSTEN bit in the SMOD register.

If the HXT oscillator is selected as the NORMAL Mode system clock and the Fast Wake-up function is enabled, then it will take one to two t_{SUB} clock cycles of the LIRC oscillator for the system to wake-up. The system will then initially run under the f_{SUB} clock source until 1024 HXT clock cycles have elapsed, at which point the HTO flag will switch high and the system will switch over to operating from the HXT oscillator.

If the ERC or HIRC oscillators or LIRC oscillator is used as the system oscillator then it will take 15~16 clock cycles of the ERC or HIRC or 1~2 cycles of the LIRC to wake up the system from the SLEEP or IDLE0 Mode. The Fast Wake-up bit, FSTEN will have no effect in these cases.

System Oscillator	FSTEN Bit	Wake-up Time (SLEEP0 Mode)	Wake-up Time (SLEEP1 Mode)	Wake-up Time (IDLE0 Mode)	Wake-up Time (IDLE1 Mode)
HXT	0	1024 HXT cycles	1024 HXT cycles	1024 HXT cycles	1~2 HXT cycles
	1	1024 HXT cycles	1~2 f_{SUB} cycles (System runs with f_{SUB} first for 1024 HXT cycles and then switches over to run with the HXT clock)	1~2 f_{SUB} cycles	1~2 HXT cycles
ERC	X	15~16 ERC cycles	15~16 ERC cycles	15~16 ERC cycles	1~2 ERC cycles
HIRC	X	15~16 HIRC cycles	15~16 HIRC cycles	15~16 HIRC cycles	1~2 HIRC cycles
LIRC	X	1~2 LIRC cycles	1~2 LIRC cycles	1~2 LIRC cycles	1~2 LIRC cycles

"X" : don't care

Wake-Up Times

Note that if the Watchdog Timer is disabled, which means that the LIRC oscillator is off, then there will be no Fast Wake-up function available when the device wakes-up from the SLEEP0 Mode.

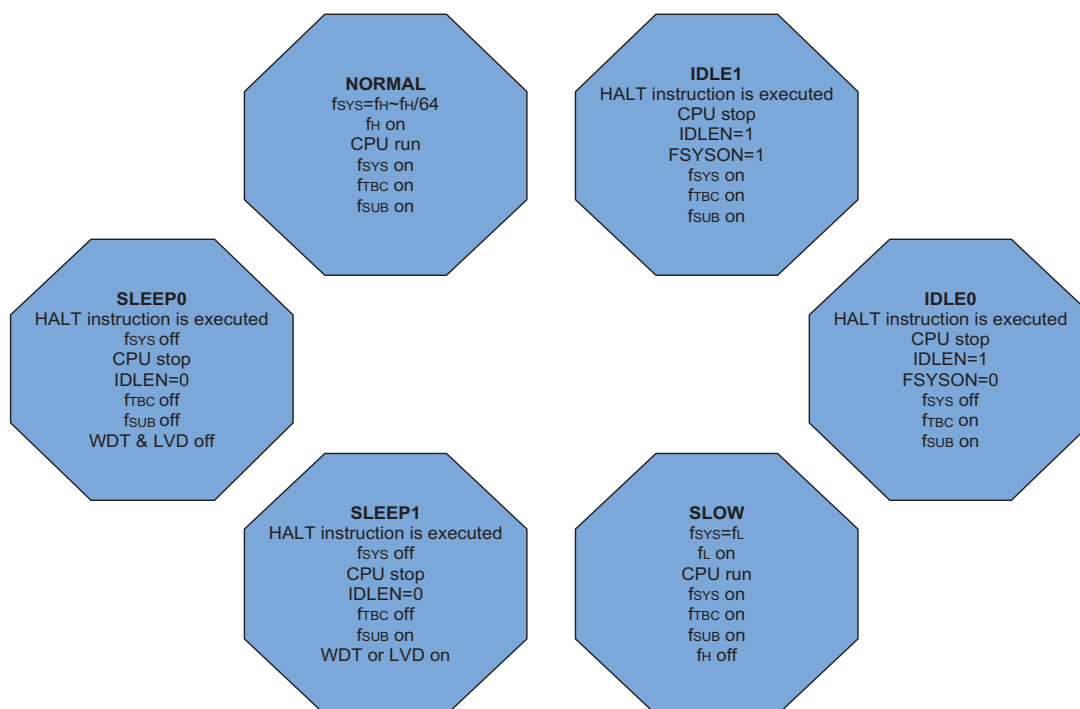

Operating Mode Switching

The device can switch between operating modes dynamically allowing the user to select the best performance/power ratio for the present task in hand. In this way microcontroller operations that do not require high performance can be executed using slower clocks thus requiring less operating current and prolonging battery life in portable applications.

In simple terms, Mode Switching between the NORMAL Mode and SLOW Mode is executed using the HLCLK bit and CKS2~CKS0 bits in the SMOD register while Mode Switching from the NORMAL/SLOW Modes to the SLEEP/IDLE Modes is executed via the HALT instruction. When a HALT instruction is executed, whether the device enters the IDLE Mode or the SLEEP Mode is determined by the condition of the IDLEN bit in the SMOD register and FSYSON in the WDTC register.

When the HLCLK bit switches to a low level, which implies that clock source is switched from the high speed clock source, f_H , to the clock source, $f_H/2 \sim f_H/64$ or f_L . If the clock is from the f_L , the high speed clock source will stop running to conserve power. When this happens it must be noted that the $f_H/16$ and $f_H/64$ internal clock sources will also stop running, which may affect the operation of other internal functions such as the TMs. The accompanying flowchart shows what happens when the device moves between the various operating modes.

NORMAL Mode to SLOW Mode Switching

When running in the NORMAL Mode, which uses the high speed system oscillator, and therefore consumes more power, the system clock can switch to run in the SLOW Mode by set the HLCLK bit to 0 and set the CKS2~CKS0 bits to "000B" or "001B" in the SMOD register. This will then use the low speed system oscillator which will consume less power. Users may decide to do this for certain operations which do not require high performance and can subsequently reduce power consumption.

The SLOW Mode is sourced from the LIRC oscillator and therefore requires these oscillators to be stable before full mode switching occurs. This is monitored using the LTO bit in the SMOD register.

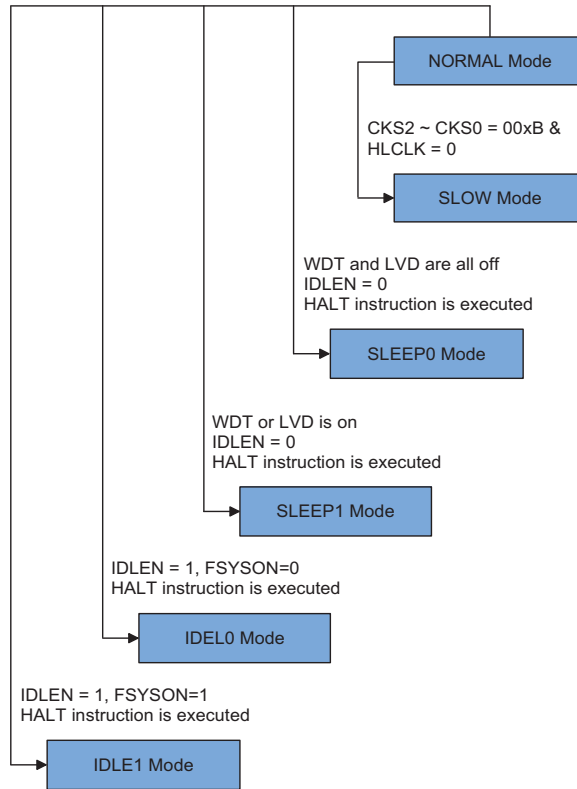

SLOW Mode to NORMAL Mode Switching

In SLOW Mode the system uses the LIRC low speed system oscillator. To switch back to the NORMAL Mode, where the high speed system oscillator is used, the HLCLK bit should be set to "1" or HLCLK bit is "0" but CKS2~CKS0 is set to 010B, 011B, 100B, 101B, 110B or 111B. As a certain amount of time will be required for the high frequency clock to stabilise, the status of the HTO bit is checked. The amount of time required for high speed system oscillator stabilization depends upon which high speed system oscillator type is used.

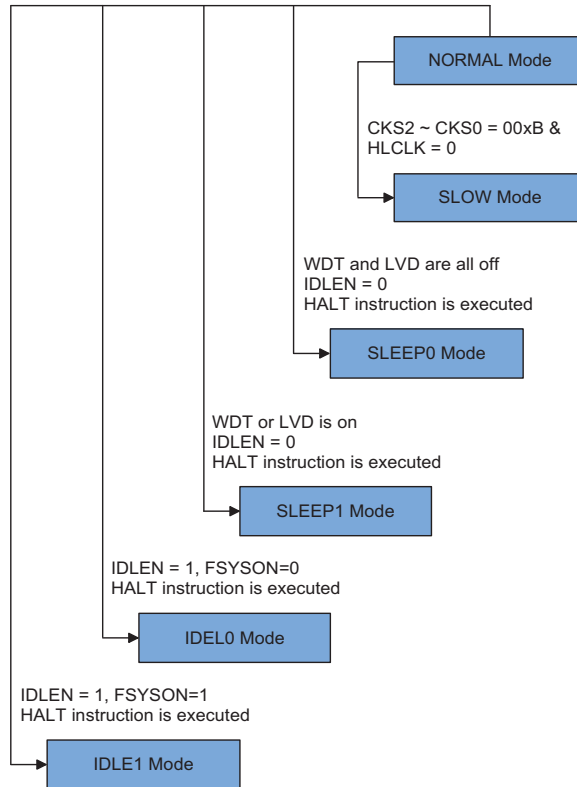

Entering the SLEEP0 Mode

There is only one way for the device to enter the SLEEP0 Mode and that is to execute the HALT instruction in the application program with the IDLEN bit in SMOD register equal to 0 and the WDT and LVD both off. When this instruction is executed under the conditions described above, the following will occur:

- The system clock, WDT clock and Time Base clock will be stopped and the application program will stop at the "HALT" instruction.
- The Data Memory contents and registers will maintain their present condition.
- The WDT will be cleared and stopped no matter if the WDT clock source originates from the f_{SUB} clock or from the system clock.
- The I/O ports will maintain their present conditions.
- In the status register, the Power Down flag, PDF, will be set and the Watchdog time-out flag, TO, will be cleared.

Entering the SLEEP1 Mode

There is only one way for the device to enter the SLEEP1 Mode and that is to execute the "HALT" instruction in the application program with the IDLEN bit in SMOD register equal to "0" and the WDT or LVD on. When this instruction is executed under the conditions described above, the following will occur:

- The system clock and Time Base clock will be stopped and the application program will stop at the "HALT" instruction, but the WDT or LVD will remain with the clock source coming from the f_{SUB} clock.
- The Data Memory contents and registers will maintain their present condition.
- The WDT will be cleared and resume counting if the WDT clock source is selected to come from the f_{SUB} clock as the WDT is enabled.
- The I/O ports will maintain their present conditions.
- In the status register, the Power Down flag, PDF, will be set and the Watchdog time-out flag, TO, will be cleared.

Entering the IDLE0 Mode

There is only one way for the device to enter the IDLE0 Mode and that is to execute the "HALT" instruction in the application program with the IDLEN bit in SMOD register equal to "1" and the FSYSON bit in WDTC register equal to "0". When this instruction is executed under the conditions described above, the following will occur:

- The system clock will be stopped and the application program will stop at the "HALT" instruction, but the Time Base clock and f_{SUB} clock will be on.
- The Data Memory contents and registers will maintain their present condition.
- The WDT will be cleared and resume counting if the WDT clock source is selected to come from the f_{SUB} clock and the WDT is enabled. The WDT will stop if its clock source originates from the system clock.
- The I/O ports will maintain their present conditions.
- In the status register, the Power Down flag, PDF, will be set and the Watchdog time-out flag, TO, will be cleared.

Entering the IDLE1 Mode

There is only one way for the device to enter the IDLE1 Mode and that is to execute the HALT instruction in the application program with the IDLEN bit in SMOD register equal to "1" and the FSYSON bit in the WDT register equal to "1". When this instruction is executed under the conditions described above, the following will occur:

- The system clock, Time Base clock and f_{SUB} clock will be on and the application program will stop at the "HALT" instruction.
- The Data Memory contents and registers will maintain their present condition.
- The WDT will be cleared and resume counting if the WDT is enabled regardless of the WDT clock source which originates from the f_{SUB} clock or from the system clock.
- The I/O ports will maintain their present conditions.
- In the status register, the Power Down flag, PDF, will be set and the Watchdog time-out flag, TO, will be cleared.

Standby Current Considerations

As the main reason for entering the SLEEP or IDLE Mode is to keep the current consumption of the device to as low a value as possible, perhaps only in the order of several micro-amps except in the IDLE1 Mode, there are other considerations which must also be taken into account by the circuit designer if the power consumption is to be minimised. Special attention must be made to the I/O pins on the device. All high-impedance input pins must be connected to either a fixed high or low level as any floating input pins could create internal oscillations and result in increased current consumption. This also applies to devices which have different package types, as there may be unbonded pins. These must either be setup as outputs or if setup as inputs must have pull-high resistors connected.

Care must also be taken with the loads, which are connected to I/O pins, which are setup as outputs. These should be placed in a condition in which minimum current is drawn or connected only to external circuits that do not draw current, such as other CMOS inputs. Also note that additional standby current will also be required if the LIRC oscillator have been enabled.

In the IDLE1 Mode the system oscillator is on, if the system oscillator is from the high speed system oscillator, the additional standby current will also be perhaps in the order of several hundred micro-amps.

Wake-up

After the system enters the SLEEP or IDLE Mode, it can be woken up from one of various sources listed as follows:

- An external reset
- An external falling edge on Port A
- A system interrupt
- A WDT overflow

If the system is woken up by an external reset, the device will experience a full system reset, however, if the device is woken up by a WDT overflow, a Watchdog Timer reset will be initiated. Although both of these wake-up methods will initiate a reset operation, the actual source of the wake-up can be determined by examining the TO and PDF flags. The PDF flag is cleared by a system power-up or executing the clear Watchdog Timer instructions and is set when executing the "HALT" instruction. The TO flag is set if a WDT time-out occurs, and causes a wake-up that only resets the Program Counter and Stack Pointer, the other flags remain in their original status.

Each pin on Port A can be setup using the PAWU register to permit a negative transition on the pin to wake-up the system. When a Port A pin wake-up occurs, the program will resume execution at the instruction following the "HALT" instruction. If the system is woken up by an interrupt, then two possible situations may occur. The first is where the related interrupt is disabled or the interrupt is enabled but the stack is full, in which case the program will resume execution at the instruction following the "HALT" instruction. In this situation, the interrupt which woke-up the device will not be immediately serviced, but will rather be serviced later when the related interrupt is finally enabled or when a stack level becomes free. The other situation is where the related interrupt is enabled and the stack is not full, in which case the regular interrupt response takes place. If an interrupt request flag is set high before entering the SLEEP or IDLE Mode, the wake-up function of the related interrupt will be disabled.

Programming Considerations

If the device is woken up from the SLEEP1 Mode to NORMAL Mode, and the system clock source is from the HXT oscillator and FSTEN is "1", the system clock can first be switched to the LIRC oscillator after wake up.

There are peripheral functions, such as WDT and TMs, for which the f_{SYS} is used. If the system clock source is switched from f_H to f_L , the clock source to the peripheral functions mentioned above will change accordingly.

The on/off condition of f_{SUB} and f_S depends upon whether the WDT is enabled or disabled as the WDT clock source is selected from f_{SUB} .

Watchdog Timer

The Watchdog Timer is provided to prevent program malfunctions or sequences from jumping to unknown locations, due to certain uncontrollable external events such as electrical noise.

Watchdog Timer Clock Source

The Watchdog Timer clock source is provided by the internal clock, f_S , which is in turn supplied by one of two sources selected by configuration option: f_{SUB} or $f_{SYS}/4$. The f_{SUB} clock is sourced from the LIRC oscillator. The LIRC internal oscillator has an approximate period of 32kHz at a supply voltage of 5V. However, it should be noted that this specified internal clock period can vary with V_{DD} , temperature and process variations. The other Watchdog Timer clock source option is the $f_{SYS}/4$ clock. The Watchdog Timer clock source can originate from the f_{SUB} clock, i.e. its own internal LIRC oscillator or $f_{SYS}/4$ determined by a configuration option. The Watchdog Timer source clock is then subdivided by a ratio of 2^8 to 2^{15} to give longer timeouts, the actual value being chosen using the WS2~WS0 bits in the WDTC register.

Watchdog Timer Control Register

A single register, WDTC, controls the required timeout period as well as the enable/disable operation. This register together with several configuration options control the overall operation of the Watchdog Timer.

WDTC Register

Bit	7	6	5	4	3	2	1	0
Name	FSYSON	WS2	WS1	WS0	WDTEN3	WDTEN2	WDTEN1	WDTEN0
R/W	R/W	R/W	R/W	R/W	R/W	R/W	R/W	R/W
POR	0	1	1	1	1	0	1	0

- Bit 7 **FSYSON**: f_{sys} Control in IDLE Mode
 0: Disable
 1: Enable
- Bit 6 ~ 4 **WS2, WS1, WS0** : WDT time-out period selection
 000: $256/f_s$
 001: $512/f_s$
 010: $1024/f_s$
 011: $2048/f_s$
 100: $4096/f_s$
 101: $8192/f_s$
 110: $16384/f_s$
 111: $32768/f_s$
- Bit 3 ~ 0 **WDTEN3, WDTEN2, WDTEN1, WDTEN0** : WDT Software Control
 1010: Disable
 Other: Enable

Watchdog Timer Operation

The Watchdog Timer operates by providing a device reset when its timer overflows. This means that in the application program and during normal operation the user has to strategically clear the Watchdog Timer before it overflows to prevent the Watchdog Timer from executing a reset. This is done using the clear watchdog instructions. If the program malfunctions for whatever reason, jumps to an unknown location, or enters an endless loop, these clear instructions will not be executed in the correct manner, in which case the Watchdog Timer will overflow and reset the device. Some of the Watchdog Timer options, such as enable/disable, clock source selection and clear instruction type are selected using configuration options. In addition to a configuration option to enable/disable the Watchdog Timer, there are also four bits, WDTEN3~WDTEN0, in the WDTC register to offer an additional enable/disable control of the Watchdog Timer. To disable the Watchdog Timer, as well as the configuration option being set to disable, the WDTEN3 ~ WDTEN0 bits must also be set to a specific value of 1010B. Any other values for these bits will keep the Watchdog Timer enabled, irrespective of the configuration enable/disable setting. After power on these bits will have the value of 1010. If the Watchdog Timer is used, it is recommended that they are set to a value of 0101B for maximum noise immunity. Note that if the Watchdog Timer has been disabled, then any instruction relating to its operation will result in no operation.

WDT Configuration Option	WDTEN3~WDTEN0 Bits	WDT
WDT Enable	xxxx	Enable
WDT Disable	Except 1010	Enable
WDT Disable	1010	Disable

"x": don't care.

Watchdog Timer Enable/Disable Control

Under normal program operation, a Watchdog Timer time-out will initialise a device reset and set the status bit TO. However, if the system is in the SLEEP or IDLE Mode, when a Watchdog Timer time-out occurs, the TO bit in the status register will be set and only the Program Counter and Stack Pointer will be reset. Three methods can be adopted to clear the contents of the Watchdog Timer. The first is an external hardware reset, which means a low level on the $\overline{\text{RES}}$ pin, the second is using the Watchdog Timer software clear instructions and the third is via a HALT instruction.

There are two methods of using software instructions to clear the Watchdog Timer, one of which must be chosen by configuration option. The first option is to use the single "CLR WDT" instruction while the second is to use the two commands "CLR WDT1" and "CLR WDT2". For the first option, a simple execution of "CLR WDT" will clear the WDT while for the second option, both "CLR WDT1" and "CLR WDT2" must both be executed alternately to successfully clear the Watchdog Timer. Note that for this second option, if "CLR WDT1" is used to clear the Watchdog Timer, successive executions of this instruction will have no effect, only the execution of a "CLR WDT2" instruction will clear the Watchdog Timer. Similarly after the "CLR WDT2" instruction has been executed, only a successive "CLR WDT1" instruction can clear the Watchdog Timer.

The maximum time out period is when the 2^{15} division ratio is selected. As an example, with a 32kHz LIRC oscillator as its source clock, this will give a maximum watchdog period of around 1 second for the 2^{15} division ratio, and a minimum timeout of 7.8ms for the 2^8 division ratio. If the $f_{\text{SYS}}/4$ clock is used as the Watchdog Timer clock source, it should be noted that when the system enters the SLEEP or IDLE0 Mode, then the instruction clock is stopped and the Watchdog Timer may lose its protecting purposes. For systems that operate in noisy environments, using the f_{SUB} clock source is strongly recommended.

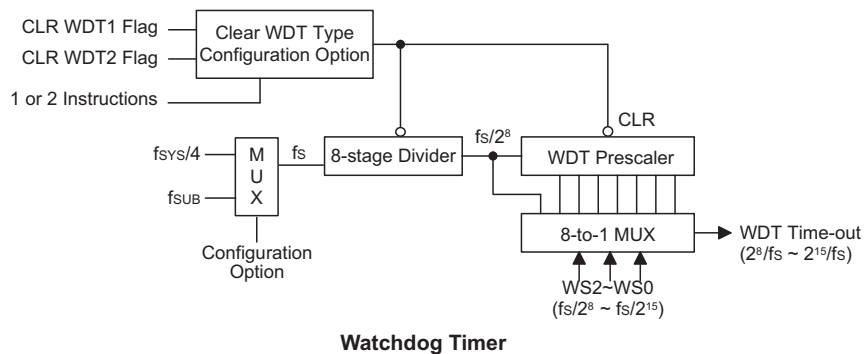

Reset and Initialisation

A reset function is a fundamental part of any microcontroller ensuring that the device can be set to some predetermined condition irrespective of outside parameters. The most important reset condition is after power is first applied to the microcontroller. In this case, internal circuitry will ensure that the microcontroller, after a short delay, will be in a well defined state and ready to execute the first program instruction. After this power-on reset, certain important internal registers will be set to defined states before the program commences. One of these registers is the Program Counter, which will be reset to zero forcing the microcontroller to begin program execution from the lowest Program Memory address.

In addition to the power-on reset, situations may arise where it is necessary to forcefully apply a reset condition when the microcontroller is running. One example of this is where after power has been applied and the microcontroller is already running, the $\overline{\text{RES}}$ line is forcefully pulled low. In such a case, known as a normal operation reset, some of the microcontroller registers remain unchanged allowing the microcontroller to precede with normal operation after the reset line is allowed to return high.

Another type of reset is when the Watchdog Timer overflows and resets the microcontroller. All types of reset operations result in different register conditions being setup. Another reset exists in the form of a Low Voltage Reset, LVR, where a full reset, similar to the $\overline{\text{RES}}$ reset is implemented in situations where the power supply voltage falls below a certain threshold.

Reset Functions

There are five ways in which a microcontroller reset can occur, through events occurring both internally and externally:

Power-on Reset

The most fundamental and unavoidable reset is the one that occurs after power is first applied to the microcontroller. As well as ensuring that the Program Memory begins execution from the first memory address, a power-on reset also ensures that certain other registers are preset to known conditions. All the I/O port and port control registers will power up in a high condition ensuring that all pins will be first set to inputs.

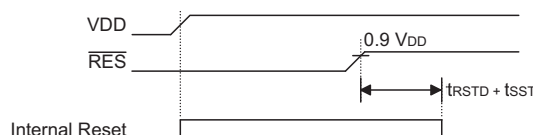

Note: t_{RSTD} is power-on delay, typical time=100ms

Power-On Reset Timing Chart

RES Pin Reset

As the reset pin is shared with PB.3, the reset function must be selected using a configuration option. Although the microcontroller has an internal RC reset function, if the VDD power supply rise time is not fast enough or does not stabilise quickly at power-on, the internal reset function may be incapable of providing proper reset operation. For this reason it is recommended that an external RC network is connected to the $\overline{\text{RES}}$ pin, whose additional time delay will ensure that the $\overline{\text{RES}}$ pin remains low for an extended period to allow the power supply to stabilise. During this time delay, normal operation of the microcontroller will be inhibited. After the $\overline{\text{RES}}$ line reaches a certain voltage value, the reset delay time t_{RSTD} is invoked to provide an extra delay time after which the microcontroller will begin normal operation. The abbreviation SST in the figures stands for System Start-up Timer. For most applications a resistor connected between VDD and the $\overline{\text{RES}}$ pin and a capacitor connected between VSS and the $\overline{\text{RES}}$ pin will provide a suitable external reset circuit. Any wiring connected to the $\overline{\text{RES}}$ pin should be kept as short as possible to minimise any stray noise interference. For applications that operate within an environment where more noise is present the Enhanced Reset Circuit shown is recommended.

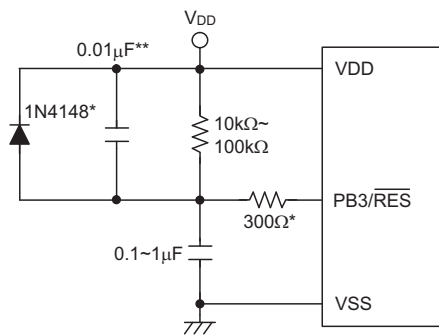

Note: "*" It is recommended that this component is added for added ESD protection

"**" It is recommended that this component is added in environments where power line noise is significant

External RES Circuit

More information regarding external reset circuits is located in Application Note HA0075E on the Holtek website.

Pulling the $\overline{\text{RES}}$ Pin low using external hardware will also execute a device reset. In this case, as in the case of other resets, the Program Counter will reset to zero and program execution initiated from this point.

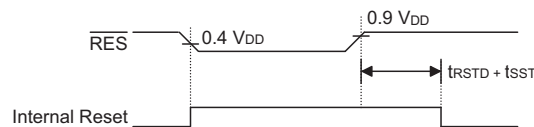

Note: t_{RSTD} is power-on delay, typical time=100ms

$\overline{\text{RES}}$ Reset Timing Chart

Low Voltage Reset – LVR

The microcontroller contains a low voltage reset circuit in order to monitor the supply voltage of the device. The LVR function is selected via a configuration option. If the supply voltage of the device drops to within a range of $0.9V \sim V_{LVR}$ such as might occur when changing the battery, the LVR will automatically reset the device internally. For a valid LVR signal, a low supply voltage, i.e., a voltage in the range between $0.9V \sim V_{LVR}$ must exist for a time greater than that specified by t_{LVR} in the A.C. characteristics. If the low supply voltage state does not exceed this value, the LVR will ignore the low supply voltage and will not perform a reset function. The actual V_{LVR} value can be selected via configuration options.

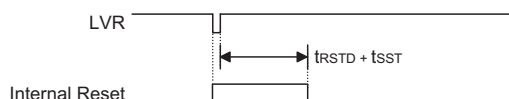

Note: t_{RSTD} is power-on delay, typical time=100ms

Low Voltage Reset Timing Chart

Watchdog Time-out Reset during Normal Operation

The Watchdog time-out Reset during normal operation is the same as a hardware \overline{RES} pin reset except that the Watchdog time-out flag TO will be set to "1".

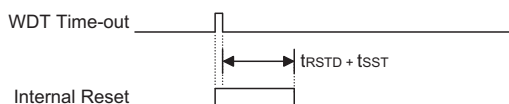

Note: t_{RSTD} is power-on delay, typical time=100ms

WDT Time-out Reset during Normal Operation Timing Chart

Watchdog Time-out Reset during SLEEP or IDLE Mode

The Watchdog time-out Reset during SLEEP or IDLE Mode is a little different from other kinds of reset. Most of the conditions remain unchanged except that the Program Counter and the Stack Pointer will be cleared to "0" and the TO flag will be set to "1". Refer to the A.C. Characteristics for t_{SST} details.

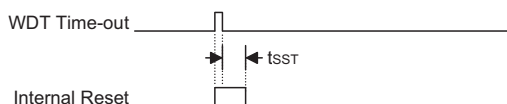

Note: The t_{SST} is 15~16 clock cycles if the system clock source is provided by ERC or HIRC.
 The t_{SST} is 1024 clock for HXT. The t_{SST} is 1~2 clock for LIRC.

WDT Time-out Reset during SLEEP or IDLE Timing Chart

Reset Initial Conditions

The different types of reset described affect the reset flags in different ways. These flags, known as PDF and TO are located in the status register and are controlled by various microcontroller operations, such as the SLEEP or IDLE Mode function or Watchdog Timer. The reset flags are shown in the table:

TO	PDF	RESET Conditions
0	0	Power-on reset
u	u	$\overline{\text{RES}}$ or LVR reset during NORMAL or SLOW Mode operation
1	u	WDT time-out reset during NORMAL or SLOW Mode operation
1	1	WDT time-out reset during IDLE or SLEEP Mode operation

Note: "u" stands for unchanged

The following table indicates the way in which the various components of the microcontroller are affected after a power-on reset occurs.

Item	Condition After RESET
Program Counter	Reset to zero
Interrupts	All interrupts will be disabled
WDT	Clear after reset, WDT begins counting
Timer/Event Counter	Timer Counter will be turned off
Input/Output Ports	I/O ports will be setup as inputs, and AN0~AN3 in as A/D input pin.
Stack Pointer	Stack Pointer will point to the top of the stack

The different kinds of resets all affect the internal registers of the microcontroller in different ways. To ensure reliable continuation of normal program execution after a reset occurs, it is important to know what condition the microcontroller is in after a particular reset occurs. The following table describes how each type of reset affects each of the microcontroller internal registers.

HT66F13 Register

Register	Reset (Power-on)	$\overline{\text{RES}}$ or LVR Reset	WDT Time-out (Normal Operation)	WDT Time-out (IDLE)
MP0	1xxx xxxx	1xxx xxxx	1xxx xxxx	1uuu uuuu
MP1	1xxx xxxx	1xxx xxxx	1xxx xxxx	1uuu uuuu
ACC	xxxx xxxx	uuuu uuuu	uuuu uuuu	uuuu uuuu
PCL	0000 0000	0000 0000	0000 0000	0000 0000
TBLP	xxxx xxxx	uuuu uuuu	uuuu uuuu	uuuu uuuu
TBHP	---- --xx	---- --uu	---- --uu	---- --uu
TBLH	--xx xxxx	--uu uuuu	--uu uuuu	--uu uuuu
STATUS	--00 xxxx	--uu uuuu	--1u uuuu	--11 uuuu
SMOD	0000 0011	0000 0011	0000 0011	uuuu uuuu
LVDC	--00 -000	--00 -000	--00 -000	--uu -uuu
INTEG	---- 0000	---- 0000	---- 0000	---- uuuu
WDTC	0111 1010	0111 1010	0111 1010	uuuu uuuu
TBC	0011 ----	0011 ----	0011 ----	uuuu ----

HT66F13/HT66F14/HT66F15
Enhanced A/D Flash Type MCU



Register	Reset (Power-on)	RES or LVR Reset	WDT Time-out (Normal Operation)	WDT Time-out (IDLE)
INTC0	-000 0000	-000 0000	-000 0000	-uuu uuuu
INTC1	0000 0000	0000 0000	0000 0000	uuuu uuuu
PAWU	0000 0000	0000 0000	0000 0000	uuuu uuuu
PAPU	0000 0000	0000 0000	0000 0000	uuuu uuuu
PA	1111 1111	1111 1111	1111 1111	uuuu uuuu
PAC	1111 1111	1111 1111	1111 1111	uuuu uuuu
PBPU	0000 0000	0000 0000	0000 0000	uuuu uuuu
PB	1111 1111	1111 1111	1111 1111	uuuu uuuu
PBC	1111 1111	1111 1111	1111 1111	uuuu uuuu
PCPU	---- --00	---- --00	---- --00	---- --uu
PC	---- --11	---- --11	---- --11	---- --uu
PCC	---- --11	---- --11	---- --11	---- --uu
ADRL (ADRFS=0)	xxxx ----	xxxx ----	xxxx ----	uuuu ----
ADRL (ADRFS=1)	xxxx xxxx	xxxx xxxx	xxxx xxxx	uuuu uuuu
ADRH (ADRFS=0)	xxxx xxxx	xxxx xxxx	xxxx xxxx	uuuu uuuu
ADRH (ADRFS=1)	---- xxxx	---- xxxx	---- xxxx	---- uuuu
ADCR0	0110 --00	0110 --00	0110 --00	uuuu --uu
ADCR1	00-0 -000	00-0 -000	00-0 -000	uu-u -uuu
ACER	---- 1111	---- 1111	---- 1111	---- uuuu
TMPC	--01 ----	--01 ----	--01 ----	--uu ----
TM1C0	0000 0000	0000 0000	0000 0000	uuuu uuuu
TM1C1	0000 0000	0000 0000	0000 0000	uuuu uuuu
TM1DL	0000 0000	0000 0000	0000 0000	uuuu uuuu
TM1DH	---- --00	---- --00	---- --00	---- --uu
TM1AL	0000 0000	0000 0000	0000 0000	uuuu uuuu
TM1AH	---- --00	---- --00	---- --00	---- --uu
SCOMC	0000 0000	0000 0000	0000 0000	uuuu uuuu

Note: "u" stands for unchanged
"x" stands for unknown
"--" stands for unimplemented

HT66F14 Register

Register	Reset (Power-on)	$\overline{\text{RES}}$ or LVR Reset	WDT Time-out (Normal Operation)	WDT Time-out (IDLE)
MP0	x x x x x x x x	x x x x x x x x	x x x x x x x x	u u u u u u u u
MP1	x x x x x x x x	x x x x x x x x	x x x x x x x x	u u u u u u u u
ACC	x x x x x x x x	u u u u u u u u	u u u u u u u u	u u u u u u u u
PCL	0 0 0 0 0 0 0 0	0 0 0 0 0 0 0 0	0 0 0 0 0 0 0 0	0 0 0 0 0 0 0 0
TBLP	x x x x x x x x	u u u u u u u u	u u u u u u u u	u u u u u u u u
TBLH	- x x x x x x x	- u u u u u u u	- u u u u u u u	- u u u u u u u
TBHP	- - - - - x x x	- - - - - u u u	- - - - - u u u	- - - - - u u u
STATUS	- - 0 0 x x x x	- - u u u u u u	- - 1 u u u u u	- - 1 1 u u u u
SMOD	0 0 0 0 0 0 1 1	0 0 0 0 0 0 1 1	0 0 0 0 0 0 1 1	u u u u u u u u
LVDC	- - 0 0 - 0 0 0	- - 0 0 - 0 0 0	- - 0 0 - 0 0 0	- - u u - u u u
INTEG	- - - - 0 0 0 0	- - - - 0 0 0 0	- - - - 0 0 0 0	- - - - u u u u
WDTC	0 1 1 1 1 0 1 0	0 1 1 1 1 0 1 0	0 1 1 1 1 0 1 0	u u u u u u u u
TBC	0 0 1 1 - - - -	0 0 1 1 - - - -	0 0 1 1 - - - -	u u u u - - - -
INTC0	- 0 0 0 0 0 0 0 0	- 0 0 0 0 0 0 0 0	- 0 0 0 0 0 0 0 0	- u u u u u u u
INTC1	0 0 0 0 0 0 0 0	0 0 0 0 0 0 0 0	0 0 0 0 0 0 0 0	u u u u u u u u
MFI0	- - 0 0 - - 0 0	- - 0 0 - - 0 0	- - 0 0 - - 0 0	- - u u - - u u
MFI1	- - 0 0 - - 0 0	- - 0 0 - - 0 0	- - 0 0 - - 0 0	- - u u - - u u
PAWU	0 0 0 0 0 0 0 0	0 0 0 0 0 0 0 0	0 0 0 0 0 0 0 0	u u u u u u u u
PAPU	0 0 0 0 0 0 0 0	0 0 0 0 0 0 0 0	0 0 0 0 0 0 0 0	u u u u u u u u
PA	1 1 1 1 1 1 1 1	1 1 1 1 1 1 1 1	1 1 1 1 1 1 1 1	u u u u u u u u
PAC	1 1 1 1 1 1 1 1	1 1 1 1 1 1 1 1	1 1 1 1 1 1 1 1	u u u u u u u u
PBPU	0 0 0 0 0 0 0 0	0 0 0 0 0 0 0 0	0 0 0 0 0 0 0 0	u u u u u u u u
PB	1 1 1 1 1 1 1 1	1 1 1 1 1 1 1 1	1 1 1 1 1 1 1 1	u u u u u u u u
PBC	1 1 1 1 1 1 1 1	1 1 1 1 1 1 1 1	1 1 1 1 1 1 1 1	u u u u u u u u
PCPU	- - - - 0 0 0 0	- - - - 0 0 0 0	- - - - 0 0 0 0	- - - - u u u u
PC	- - - - 1 1 1 1	- - - - 1 1 1 1	- - - - 1 1 1 1	- - - - u u u u
PCC	- - - - 1 1 1 1	- - - - 1 1 1 1	- - - - 1 1 1 1	- - - - u u u u
PDPU	- - - - - 0 0	- - - - - 0 0	- - - - - 0 0	- - - - - u u
PD	- - - - - 1 1	- - - - - 1 1	- - - - - 1 1	- - - - - u u
PDC	- - - - - 1 1	- - - - - 1 1	- - - - - 1 1	- - - - - u u
ADRL (ADRFS=0)	x x x x - - - -	x x x x - - - -	x x x x - - - -	u u u u - - - -
ADRL (ADRFS=1)	x x x x x x x x	x x x x x x x x	x x x x x x x x	u u u u u u u u
ADRH (ADRFS=0)	x x x x x x x x	x x x x x x x x	x x x x x x x x	u u u u u u u u
ADRH (ADRFS=1)	- - - - x x x x	- - - - x x x x	- - - - x x x x	- - - - u u u u
ADCR0	0 1 1 0 - - 0 0	0 1 1 0 - - 0 0	0 1 1 0 - - 0 0	u u u u - - u u
ADCR1	0 0 - 0 - 0 0 0	0 0 - 0 - 0 0 0	0 0 - 0 - 0 0 0	u u - u - u u u

HT66F13/HT66F14/HT66F15
Enhanced A/D Flash Type MCU



Register	Reset (Power-on)	RES or LVR Reset	WDT Time-out (Normal Operation)	WDT Time-out (IDLE)
ACER	---- 1111	---- 1111	---- 1111	---- uuuu
TMPC	--01 --01	--01 --01	--01 --01	--uu --uu
TM0C0	0000 0000	0000 0000	0000 0000	uuuu uuuu
TM0C1	0000 0000	0000 0000	0000 0000	uuuu uuuu
TM0DL	0000 0000	0000 0000	0000 0000	uuuu uuuu
TM0DH	---- --00	---- --00	---- --00	---- --uu
TM0AL	0000 0000	0000 0000	0000 0000	uuuu uuuu
TM0AH	---- --00	---- --00	---- --00	---- --uu
TM1C0	0000 0000	0000 0000	0000 0000	uuuu uuuu
TM1C1	0000 0000	0000 0000	0000 0000	uuuu uuuu
TM1DL	0000 0000	0000 0000	0000 0000	uuuu uuuu
TM1DH	---- --00	---- --00	---- --00	---- --uu
TM1AL	0000 0000	0000 0000	0000 0000	uuuu uuuu
TM1AH	---- --00	---- --00	---- --00	---- --uu
SCOMC	0000 0000	0000 0000	0000 0000	uuuu uuuu

Note: "u" stands for unchanged
"x" stands for unknown
"--" stands for unimplemented

HT66F15 Register

Register	Reset (Power-on)	RES or LVR Reset	WDT Time-out (Normal Operation)	WDT Time-out (IDLE)
MP0	x x x x x x x x	x x x x x x x x	x x x x x x x x	u u u u u u u u
MP1	x x x x x x x x	x x x x x x x x	x x x x x x x x	u u u u u u u u
ACC	x x x x x x x x	u u u u u u u u	u u u u u u u u	u u u u u u u u
PCL	0 0 0 0 0 0 0 0	0 0 0 0 0 0 0 0	0 0 0 0 0 0 0 0	0 0 0 0 0 0 0 0
TBLP	x x x x x x x x	u u u u u u u u	u u u u u u u u	u u u u u u u u
TBLH	- x x x x x x x	- u u u u u u u	- u u u u u u u	- u u u u u u u
TBHP	- - - - x x x x	- - - - u u u u	- - - - u u u u	- - - - u u u u
STATUS	- - 0 0 x x x x	- - u u u u u u	- - 1 u u u u u	- - 1 1 u u u u
SMOD	0 0 0 0 0 0 1 1	0 0 0 0 0 0 1 1	0 0 0 0 0 0 1 1	u u u u u u u u
LVDC	- - 0 0 - 0 0 0	- - 0 0 - 0 0 0	- - 0 0 - 0 0 0	- - u u - u u u
INTEG	- - - - 0 0 0 0	- - - - 0 0 0 0	- - - - 0 0 0 0	- - - - u u u u
WDTC	0 1 1 1 1 0 1 0	0 1 1 1 1 0 1 0	0 1 1 1 1 0 1 0	u u u u u u u u
TBC	0 0 1 1 - - - -	0 0 1 1 - - - -	0 0 1 1 - - - -	u u u u - - - -
INTC0	- 0 0 0 0 0 0 0	- 0 0 0 0 0 0 0	- 0 0 0 0 0 0 0	- u u u u u u u
INTC1	0 0 0 0 0 0 0 0	0 0 0 0 0 0 0 0	0 0 0 0 0 0 0 0	u u u u u u u u
MFI0	- - 0 0 - - 0 0	- - 0 0 - - 0 0	- - 0 0 - - 0 0	- - u u - - u u
MFI1	- 0 0 0 - 0 0 0	- 0 0 0 - 0 0 0	- 0 0 0 - 0 0 0	- u u u - u u u
PAWU	0 0 0 0 0 0 0 0	0 0 0 0 0 0 0 0	0 0 0 0 0 0 0 0	u u u u u u u u
PAPU	0 0 0 0 0 0 0 0	0 0 0 0 0 0 0 0	0 0 0 0 0 0 0 0	u u u u u u u u
PA	1 1 1 1 1 1 1 1	1 1 1 1 1 1 1 1	1 1 1 1 1 1 1 1	u u u u u u u u
PAC	1 1 1 1 1 1 1 1	1 1 1 1 1 1 1 1	1 1 1 1 1 1 1 1	u u u u u u u u
PBPU	0 0 0 0 0 0 0 0	0 0 0 0 0 0 0 0	0 0 0 0 0 0 0 0	u u u u u u u u
PB	1 1 1 1 1 1 1 1	1 1 1 1 1 1 1 1	1 1 1 1 1 1 1 1	u u u u u u u u
PBC	1 1 1 1 1 1 1 1	1 1 1 1 1 1 1 1	1 1 1 1 1 1 1 1	u u u u u u u u
PCPU	0 0 0 0 0 0 0 0	0 0 0 0 0 0 0 0	0 0 0 0 0 0 0 0	u u u u u u u u
PC	1 1 1 1 1 1 1 1	1 1 1 1 1 1 1 1	1 1 1 1 1 1 1 1	u u u u u u u u
PCC	1 1 1 1 1 1 1 1	1 1 1 1 1 1 1 1	1 1 1 1 1 1 1 1	u u u u u u u u
PDPU	- - - - - 0 0	- - - - - 0 0	- - - - - 0 0	- - - - - u u
PD	- - - - - 1 1	- - - - - 1 1	- - - - - 1 1	- - - - - u u
PDC	- - - - - 1 1	- - - - - 1 1	- - - - - 1 1	- - - - - u u
ADRL (ADRFS=0)	x x x x - - - -	x x x x - - - -	x x x x - - - -	u u u u - - - -
ADRL (ADRFS=1)	x x x x x x x x	x x x x x x x x	x x x x x x x x	u u u u u u u u
ADRH (ADRFS=0)	x x x x x x x x	x x x x x x x x	x x x x x x x x	u u u u u u u u
ADRH (ADRFS=1)	- - - - x x x x	- - - - x x x x	- - - - x x x x	- - - - u u u u
ADCR0	0 1 1 0 - - 0 0	0 1 1 0 - - 0 0	0 1 1 0 - - 0 0	u u u u - - u u
ADCR1	0 0 - 0 - 0 0 0	0 0 - 0 - 0 0 0	0 0 - 0 - 0 0 0	u u - u - u u u

HT66F13/HT66F14/HT66F15
Enhanced A/D Flash Type MCU



Register	Reset (Power-on)	RES or LVR Reset	WDT Time-out (Normal Operation)	WDT Time-out (IDLE)
ACER	---- 1111	---- 1111	---- 1111	---- uuuu
TMPC	1001 --01	1001 --01	1001 --01	uuuu --uu
TM0C0	0000 0000	0000 0000	0000 0000	uuuu uuuu
TM0C1	0000 0000	0000 0000	0000 0000	uuuu uuuu
TM0DL	0000 0000	0000 0000	0000 0000	uuuu uuuu
TM0DH	---- --00	---- --00	---- --00	---- --uu
TM0AL	0000 0000	0000 0000	0000 0000	uuuu uuuu
TM0AH	---- --00	---- --00	---- --00	---- --uu
TM1C0	0000 0000	0000 0000	0000 0000	uuuu uuuu
TM1C1	0000 0000	0000 0000	0000 0000	uuuu uuuu
TM1C2	0000 0000	0000 0000	0000 0000	uuuu uuuu
TM1DL	0000 0000	0000 0000	0000 0000	uuuu uuuu
TM1DH	---- --00	---- --00	---- --00	---- --uu
TM1AL	0000 0000	0000 0000	0000 0000	uuuu uuuu
TM1AH	---- --00	---- --00	---- --00	---- --uu
TM1BL	0000 0000	0000 0000	0000 0000	uuuu uuuu
TM1BH	---- --00	---- --00	---- --00	---- --uu
SCOMC	0000 0000	0000 0000	0000 0000	uuuu uuuu

Note: "u" stands for unchanged
"x" stands for unknown
"--" stands for unimplemented

Input/Output Ports

Holtek microcontrollers offer considerable flexibility on their I/O ports. With the input or output designation of every pin fully under user program control, pull-high selections for all ports and wake-up selections on certain pins, the user is provided with an I/O structure to meet the needs of a wide range of application possibilities.

The device provides bidirectional input/output lines labeled with port names PA~PD. These I/O ports are mapped to the RAM Data Memory with specific addresses as shown in the Special Purpose Data Memory table. All of these I/O ports can be used for input and output operations. For input operation, these ports are non-latching, which means the inputs must be ready at the T2 rising edge of instruction "MOV A,[m]", where m denotes the port address. For output operation, all the data is latched and remains unchanged until the output latch is rewritten.

I/O Register List

HT66F13

Register Name	Bit							
	7	6	5	4	3	2	1	0
PAWU	D7	D6	D5	D4	D3	D2	D1	D0
PAPU	D7	D6	D5	D4	D3	D2	D1	D0
PA	D7	D6	D5	D4	D3	D2	D1	D0
PAC	D7	D6	D5	D4	D3	D2	D1	D0
PBPU	D7	D6	D5	D4	D3	D2	D1	D0
PB	D7	D6	D5	D4	D3	D2	D1	D0
PBC	D7	D6	D5	D4	D3	D2	D1	D0
PCPU	—	—	—	—	—	—	D1	D0
PC	—	—	—	—	—	—	D1	D0
PCC	—	—	—	—	—	—	D1	D0

HT66F14

Register Name	Bit							
	7	6	5	4	3	2	1	0
PAWU	D7	D6	D5	D4	D3	D2	D1	D0
PAPU	D7	D6	D5	D4	D3	D2	D1	D0
PA	D7	D6	D5	D4	D3	D2	D1	D0
PAC	D7	D6	D5	D4	D3	D2	D1	D0
PBPU	D7	D6	D5	D4	D3	D2	D1	D0
PB	D7	D6	D5	D4	D3	D2	D1	D0
PBC	D7	D6	D5	D4	D3	D2	D1	D0
PCPU	—	—	—	—	D3	D2	D1	D0
PC	—	—	—	—	D3	D2	D1	D0
PCC	—	—	—	—	D3	D2	D1	D0
PDPU	—	—	—	—	—	—	D1	D0
PD	—	—	—	—	—	—	D1	D0
PDC	—	—	—	—	—	—	D1	D0

HT66F15

Register Name	Bit							
	7	6	5	4	3	2	1	0
PAWU	D7	D6	D5	D4	D3	D2	D1	D0
PAPU	D7	D6	D5	D4	D3	D2	D1	D0
PA	D7	D6	D5	D4	D3	D2	D1	D0
PAC	D7	D6	D5	D4	D3	D2	D1	D0
PBPU	D7	D6	D5	D4	D3	D2	D1	D0
PB	D7	D6	D5	D4	D3	D2	D1	D0
PBC	D7	D6	D5	D4	D3	D2	D1	D0
PCPU	D7	D6	D5	D4	D3	D2	D1	D0
PC	D7	D6	D5	D4	D3	D2	D1	D0
PCC	D7	D6	D5	D4	D3	D2	D1	D0
PDPU	—	—	—	—	—	—	D1	D0
PD	—	—	—	—	—	—	D1	D0
PDC	—	—	—	—	—	—	D1	D0

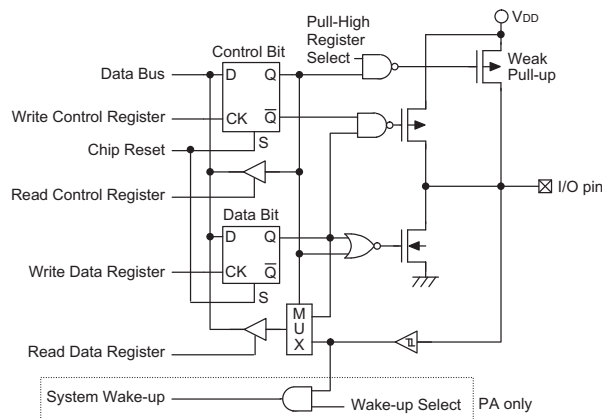

Generic Input/Output Structure

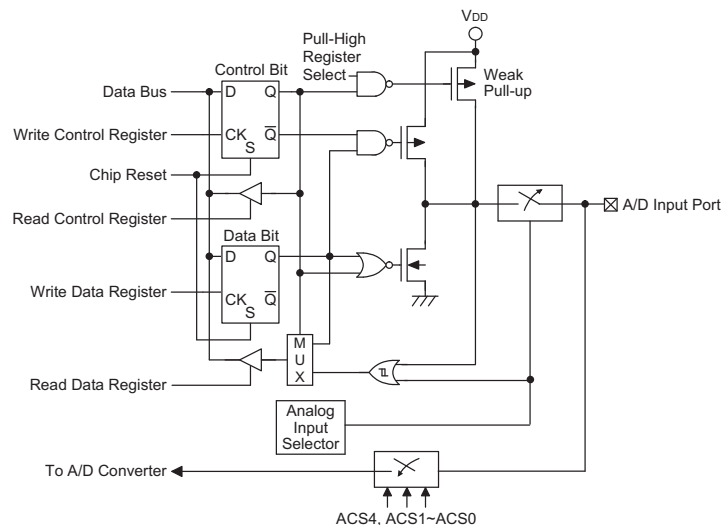

A/D Input/Output Structure

Pull-high Resistors

Many product applications require pull-high resistors for their switch inputs usually requiring the use of an external resistor. To eliminate the need for these external resistors, all I/O pins, when configured as an input have the capability of being connected to an internal pull-high resistor. These pull-high resistors are selected using registers PAPU~PDPU and are implemented using weak PMOS transistors.

PAPU Register

Bit	7	6	5	4	3	2	1	0
Name	D7	D6	D5	D4	D3	D2	D1	D0
R/W	R/W	R/W	R/W	R/W	R/W	R/W	R/W	R/W
POR	0	0	0	0	0	0	0	0

Bit 7~0 I/O Port A bit 7 ~ bit 0 pull-high control
 0: disable
 1: enable

PBPU Register

Bit	7	6	5	4	3	2	1	0
Name	D7	D6	D5	D4	D3	D2	D1	D0
R/W	R/W	R/W	R/W	R/W	R/W	R/W	R/W	R/W
POR	0	0	0	0	0	0	0	0

Bit 7~0 I/O Port B bit 7 ~ bit 0 pull-high control
 0: disable
 1: enable

PCPU Register – HT66F13

Bit	7	6	5	4	3	2	1	0
Name	—	—	—	—	—	—	D1	D0
R/W	—	—	—	—	—	—	R/W	R/W
POR	—	—	—	—	—	—	0	0

Bit 7~2 "—" Unimplemented, read as "0"
 Bit 1~0 I/O Port C bit 1 ~ bit 0 pull-high control
 0: disable
 1: enable

PCPU Register – HT66F14

Bit	7	6	5	4	3	2	1	0
Name	—	—	—	—	D3	D2	D1	D0
R/W	—	—	—	—	R/W	R/W	R/W	R/W
POR	—	—	—	—	0	0	0	0

Bit 7~4 "—" Unimplemented, read as "0"
 Bit 3~0 I/O Port C bit 3 ~ bit 0 pull-high control
 0: disable
 1: enable

PCPU Register – HT66F15

Bit	7	6	5	4	3	2	1	0
Name	D7	D6	D5	D4	D3	D2	D1	D0
R/W	R/W	R/W	R/W	R/W	R/W	R/W	R/W	R/W
POR	0	0	0	0	0	0	0	0

Bit 7~0 I/O Port C bit 7 ~ bit 0 pull-high control
 0: disable
 1: enable

PDPU Register – HT66F14, HT66F15

Bit	7	6	5	4	3	2	1	0
Name	—	—	—	—	—	—	D1	D0
R/W	—	—	—	—	—	—	R/W	R/W
POR	—	—	—	—	—	—	0	0

Bit 7~2 “—” Unimplemented, read as “0”

Bit 1~0 I/O Port D bit 1 ~ bit 0 pull-high control
 0: disable
 1: enable

Port A Wake-up

The HALT instruction forces the microcontroller into the SLEEP or IDLE Mode which preserves power, a feature that is important for battery and other low-power applications. Various methods exist to wake-up the microcontroller, one of which is to change the logic condition on one of the Port A pins from high to low. This function is especially suitable for applications that can be woken up via external switches. Each pin on Port A can be selected individually to have this wake-up feature using the PAWU register.

PAWU Register

Bit	7	6	5	4	3	2	1	0
Name	D7	D6	D5	D4	D3	D2	D1	D0
R/W	R/W	R/W	R/W	R/W	R/W	R/W	R/W	R/W
POR	0	0	0	0	0	0	0	0

Bit 7~0 **PAWU**: Port A bit 7 ~ bit 0 wake-up control
 0: disable
 1: enable

I/O Port Control Registers

Each I/O port has its own control register known as PAC~PDC, to control the input/output configuration. With this control register, each CMOS output or input can be reconfigured dynamically under software control. Each pin of the I/O ports is directly mapped to a bit in its associated port control register. For the I/O pin to function as an input, the corresponding bit of the control register must be written as 1. This will then allow the logic state of the input pin to be directly read by instructions. When the corresponding bit of the control register is written as 0, the I/O pin will be setup as a CMOS output. If the pin is currently setup as an output, instructions can still be used to read the output register. However, it should be noted that the program will in fact only read the status of the output data latch and not the actual logic status of the output pin.

PAC Register

Bit	7	6	5	4	3	2	1	0
Name	D7	D6	D5	D4	D3	D2	D1	D0
R/W	R/W	R/W	R/W	R/W	R/W	R/W	R/W	R/W
POR	1	1	1	1	1	1	1	1

Bit 7~0 I/O Port A bit 7 ~ bit 0 input/output control
 0: output
 1: input

PBC Register

Bit	7	6	5	4	3	2	1	0
Name	D7	D6	D5	D4	D3	D2	D1	D0
R/W	R/W	R/W	R/W	R/W	R/W	R/W	R/W	R/W
POR	1	1	1	1	1	1	1	1

Bit 7~0 I/O Port B bit 7 ~ bit 0 input/output control
 0: output
 1: input

PCC Register – HT66F13

Bit	7	6	5	4	3	2	1	0
Name	—	—	—	—	—	—	D1	D0
R/W	—	—	—	—	—	—	R/W	R/W
POR	—	—	—	—	—	—	1	1

Bit 7~2 "—" Unimplemented, read as "0"
 Bit 1~0 I/O Port C bit 1 ~ bit 0 input/output control
 0: output
 1: input

PCC Register – HT66F14

Bit	7	6	5	4	3	2	1	0
Name	—	—	—	—	D3	D2	D1	D0
R/W	—	—	—	—	R/W	R/W	R/W	R/W
POR	—	—	—	—	1	1	1	1

Bit 7~4 "—" Unimplemented, read as "0"
 Bit 3~0 I/O Port C bit 3 ~ bit 0 input/output control
 0: output
 1: input

PCC Register – HT66F15

Bit	7	6	5	4	3	2	1	0
Name	D7	D6	D5	D4	D3	D2	D1	D0
R/W	R/W	R/W	R/W	R/W	R/W	R/W	R/W	R/W
POR	1	1	1	1	1	1	1	1

Bit 7~0 I/O Port C bit 7 ~ bit 0 input/output control
 0: output
 1: input

PDC Register – HT66F14, HT66F15

Bit	7	6	5	4	3	2	1	0
Name	—	—	—	—	—	—	D1	D0
R/W	—	—	—	—	—	—	R/W	R/W
POR	—	—	—	—	—	—	0	0

Bit 7~2 "—" Unimplemented, read as "0"

Bit 1~0 I/O Port D bit 1 ~ bit 0 input/output control
 0: output
 1: input

I/O Pin Structures

The accompanying diagrams illustrate the internal structures of some generic I/O pin types. As the exact logical construction of the I/O pin will differ from these drawings, they are supplied as a guide only to assist with the functional understanding of the I/O pins. The wide range of pin-shared structures does not permit all types to be shown. The diagrams illustrate the I/O pin internal structures. As the exact logical construction of the I/O pin may differ from these drawings, they are supplied as a guide only to assist with the functional understanding of the I/O pins.

Programming Considerations

Within the user program, one of the first things to consider is port initialisation. After a reset, all of the I/O data and port control registers will be set high. This means that all I/O pins will default to an input state, the level of which depends on the other connected circuitry and whether pull-high selections have been chosen. If the port control registers, PAC~PDC, are then programmed to setup some pins as outputs, these output pins will have an initial high output value unless the associated port data registers, PA~PD, are first programmed. Selecting which pins are inputs and which are outputs can be achieved byte-wide by loading the correct values into the appropriate port control register or by programming individual bits in the port control register using the "SET [m].i" and "CLR [m].i" instructions. Note that when using these bit control instructions, a read-modify-write operation takes place. The microcontroller must first read in the data on the entire port, modify it to the required new bit values and then rewrite this data back to the output ports.

Port A has the additional capability of providing wake-up functions. When the device is in the SLEEP or IDLE Mode, various methods are available to wake the device up. One of these is a high to low transition of any of the Port A pins. Single or multiple pins on Port A can be setup to have this function.

Timer Modules – TM

One of the most fundamental functions in any microcontroller device is the ability to control and measure time. To implement time related functions each device includes several Timer Modules, abbreviated to the name TM. The TMs are multi-purpose timing units and serve to provide operations such as Timer/Counter, Input Capture, Compare Match Output and Single Pulse Output as well as being the functional unit for the generation of PWM signals. Each of the TMs has either two or three individual interrupts. The addition of input and output pins for each TM ensures that users are provided with timing units with a wide and flexible range of features.

The common features of the different TM types are described here with more detailed information provided in the individual Compact, Standard and Enhanced TM sections.

Introduction

The devices contain up to two TMs with each TM having a reference name of TM0 and TM1. Each individual TM can be categorised as a certain type, namely Compact Type TM (CTM), Standard Type TM (STM) or Enhanced Type TM (ETM). Although similar in nature, the different TM types vary in their feature complexity. The common features to all of the Compact, Standard and Enhanced TMs will be described in this section and the detailed operation regarding each of the TM types will be described in separate sections. The main features and differences between the three types of TMs are summarised in the accompanying table.

Function	CTM	STM	ETM
Timer/Counter	√	√	√
I/P Capture	—	√	√
Compare Match Output	√	√	√
PWM Channels	1	1	2
Single Pulse Output	—	1	2
PWM Alignment	Edge	Edge	Edge & Centre
PWM Adjustment Period & Duty	Duty or Period	Duty or Period	Duty or Period

TM Function Summary

Each device in the series contains a specific number of either Compact Type, Standard Type and Enhanced Type TM units which are shown in the table together with their individual reference name, TM0~TM1.

Device	TM0	TM1
HT66F13	—	10-bit STM
HT66F14	10-bit CTM	10-bit STM
HT66F15	10-bit CTM	10-bit ETM

TM Name/Type Reference

TM Operation

The three different types of TM offer a diverse range of functions, from simple timing operations to PWM signal generation. The key to understanding how the TM operates is to see it in terms of a free running counter whose value is then compared with the value of pre-programmed internal comparators. When the free running counter has the same value as the pre-programmed comparator, known as a compare match situation, a TM interrupt signal will be generated which can clear the counter and perhaps also change the condition of the TM output pin. The internal TM counter is driven by a user selectable clock source, which can be an internal clock or an external pin.

TM Clock Source

The clock source which drives the main counter in each TM can originate from various sources. The selection of the required clock source is implemented using the TnCK2~TnCK0 bits in the TM control registers. The clock source can be a ratio of either the system clock f_{SYS} or the high speed clock f_H , the f_{TBC} clock source or the external TCKn pin. Note that setting these bits to the value 101 will select a reserved clock input, in effect disconnecting the TM clock source. The TCKn pin clock source is used to allow an external signal to drive the TM as an external clock source or for event counting.

TM Interrupts

The Compact and Standard type TMs each have two internal interrupts, one for each of the internal comparator A or comparator P, which generate a TM interrupt when a compare match condition occurs. As the Enhanced type TM has three internal comparators and comparator A or comparator B or comparator P compare match functions, it consequently has three internal interrupts. When a TM interrupt is generated it can be used to clear the counter and also to change the state of the TM output pin.

TM External Pins

Each of the TMs, irrespective of what type, has one TM input pin, with the label TCKn. The TM input pin, is essentially a clock source for the TM and is selected using the TnCK2~TnCK0 bits in the TmCn0 register. This external TM input pin allows an external clock source to drive the internal TM. This external TM input pin is shared with other functions but will be connected to the internal TM if selected using the TnCK2~TnCK0 bits. The TM input pin can be chosen to have either a rising or falling active edge.

The TMs each have one or more output pins with the label TPn. When the TM is in the Compare Match Output Mode, these pins can be controlled by the TM to switch to a high or low level or to toggle when a compare match situation occurs. The external TPn output pin is also the pin where the TM generates the PWM output waveform. As the TM output pins are pin-shared with other function, the TM output function must first be setup using registers. A single bit in one of the registers determines if its associated pin is to be used as an external TM output pin or if it is to have another function. The number of output pins for each TM type and device is different, the details are provided in the accompanying table.

All TM output pin names have an "_n" suffix. Pin names that include a "_1" or "_2" suffix indicate that they are from a TM with multiple output pins. This allows the TM to generate a complimentary output pair, selected using the I/O register data bits.

Device	CTM	STM	ETM	Registers
HT66F13	—	TP1_0, TP1_1	—	TMPC
HT66F14	TP0_0, TP0_1	TP1_0, TP1_1	—	TMPC
HT66F15	TP0_0, TP0_1	—	TP1A, TP1B_0, TP1B_1, TP1B_2	TMPC

TM Output Pins

TM Input/Output Pin Control Registers

Selecting to have a TM input/output or whether to retain its other shared function is implemented using one register, with a single bit in each register corresponding to a TM input/output pin. Setting the bit high will setup the corresponding pin as a TM input/output, if reset to zero the pin will retain its original other function.

TMPC Register

Device	Bit							
	7	6	5	4	3	2	1	0
HT66F13	—	—	T1CP1	T1CP0	—	—	—	—
HT66F14	—	—	T1CP1	T1CP0	—	—	T0CP1	T0CP0
HT66F15	T1ACP0	T1BCP2	T1BCP1	T1BCP0	—	—	T0CP1	T0CP0

TM Input/Output Pin Control Registers List

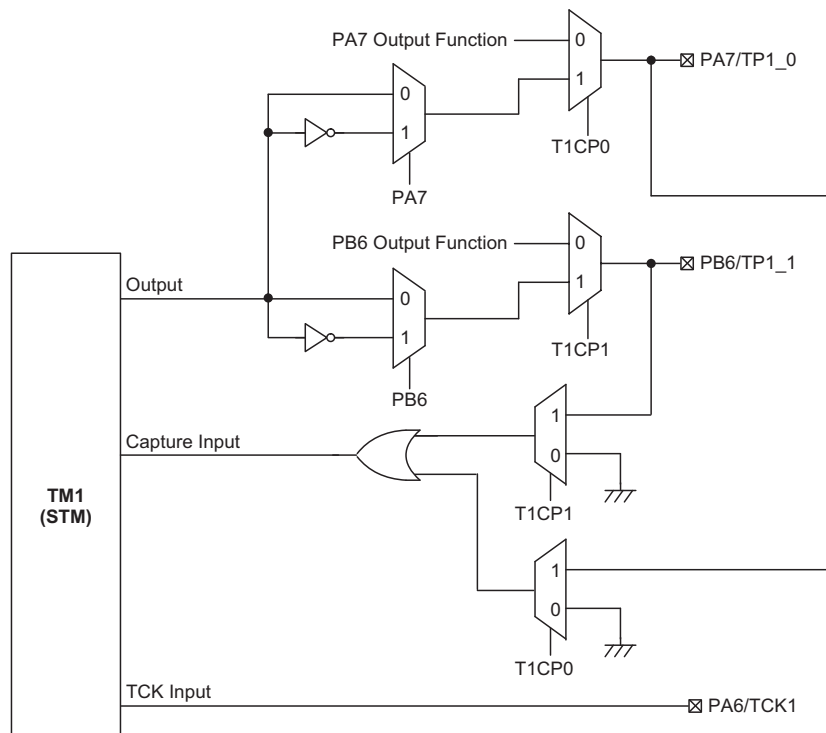

HT66F13 TM Function Pin Control Block Diagram

- Note:
1. The I/O register data bits shown are used for TM output inversion control.
 2. In the Capture Input Mode, the TM pin control register must never enable more than one TM input.

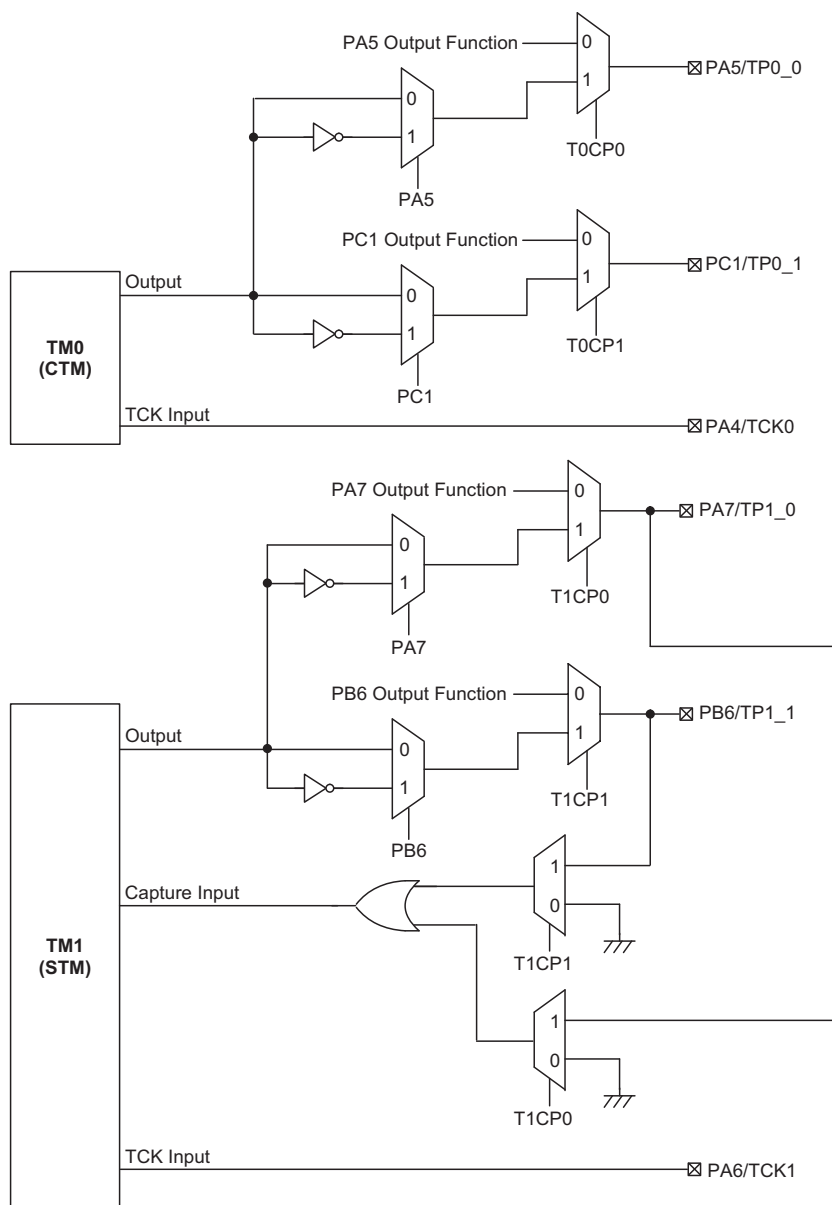

HT66F14 TM0 & TM1 Function Pin Control Block Diagram

- Note:
1. The I/O register data bits shown are used for TM output inversion control.
 2. In the Capture Input Mode, the TM pin control register must never enable more than one TM input.

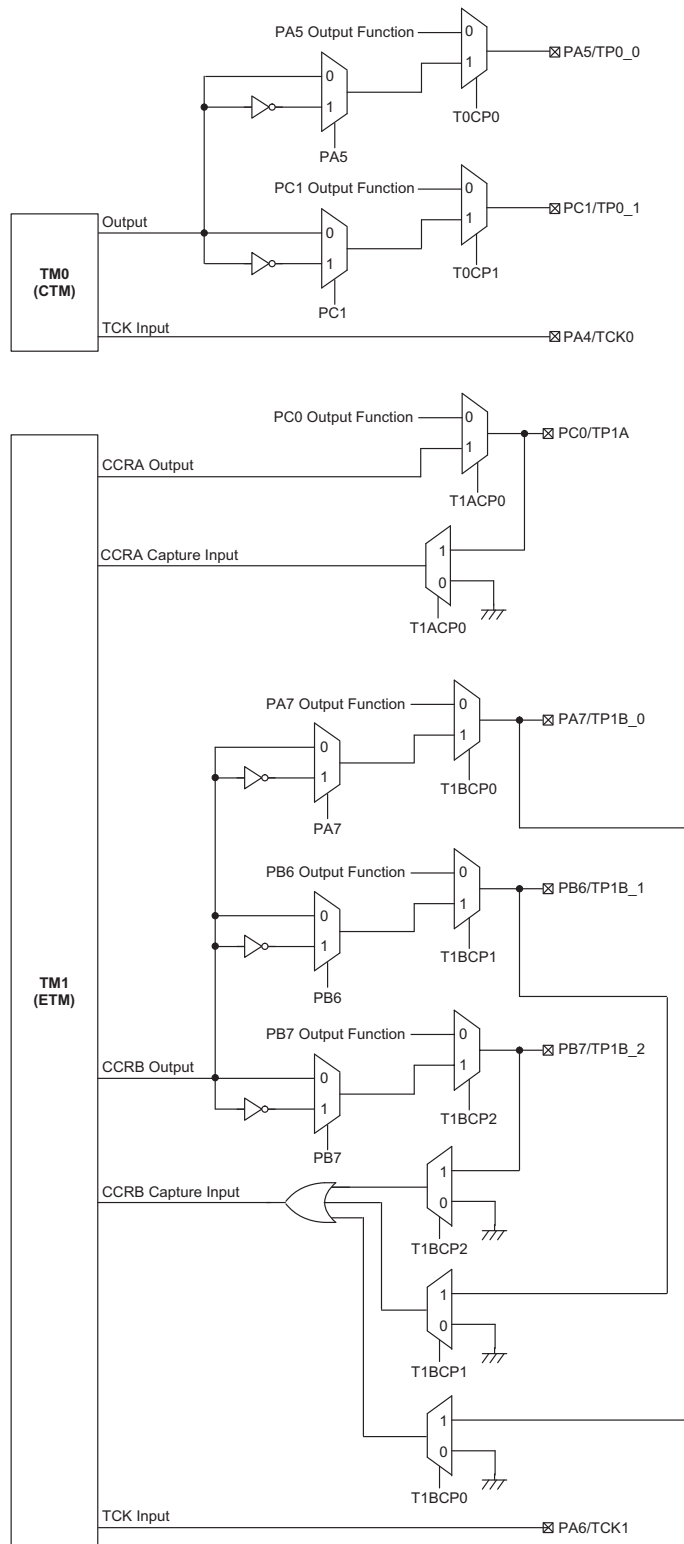

HT66F15 TM0 & TM1 Function Pin Control Block Diagram

- Note:
1. The I/O register data bits shown are used for TM output inversion control.
 2. In the Capture Input Mode, the TM pin control register must never enable more than one TM input.

TMPC Register – HT66F13

Bit	7	6	5	4	3	2	1	0
Name	—	—	T1CP1	T1CP0	—	—	—	—
R/W	—	—	R/W	R/W	—	—	—	—
POR	—	—	0	1	—	—	—	—

- Bit 7, 6 Unimplemented, read as "0"
- Bit 5 **T1CP1**: TP1_1 pin enable control
0: disable
1: enable
- Bit 4 **T1CP0**: TP1_0 pin enable control
0: disable
1: enable
- Bit 3~0 Unimplemented, read as "0"

TMPC Register – HT66F14

Bit	7	6	5	4	3	2	1	0
Name	—	—	T1CP1	T1CP0	—	—	T0CP1	T0CP0
R/W	—	—	R/W	R/W	—	—	R/W	R/W
POR	—	—	0	1	—	—	0	1

- Bit 7~6 Unimplemented, read as "0"
- Bit 5 **T1CP1**: TP1_1 pin enable control
0: disable
1: enable
- Bit 4 **T1CP0**: TP1_0 pin enable control
0: disable
1: enable
- Bit 3~2 Unimplemented, read as "0"
- Bit 1 **T0CP1**: TP0_1 pin enable control
0: disable
1: enable
- Bit 0 **T0CP0**: TP0_0 pin enable control
0: disable
1: enable

TMPC Register – HT66F15

Bit	7	6	5	4	3	2	1	0
Name	T1ACP0	T1BCP2	T1BCP1	T1BCP0	—	—	T0CP1	T0CP0
R/W	R/W	R/W	R/W	R/W	—	—	R/W	R/W
POR	1	0	0	1	—	—	0	1

- Bit 7 **T1ACP0**: TP1A pin enable control
0: disable
1: enable
- Bit 6 **T1BCP2**: TP1B_2 pin enable control
0: disable
1: enable
- Bit 5 **T1BCP1**: TP1B_1 pin enable control
0: disable
1: enable
- Bit 4 **T1BCP0**: TP1B_0 pin enable control
0: disable
1: enable
- Bit 3~2 Unimplemented, read as "0"
- Bit 1 **T0CP1**: TP0_1 pin enable control
0: disable
1: enable
- Bit 0 **T0CP0**: TP0_0 pin enable control
0: disable
1: enable

Programming Considerations

The TM Counter Registers and the Capture/Compare CCRA and CCRB registers, being either 10-bit or 16-bit, all have a low and high byte structure. The high bytes can be directly accessed, but as the low bytes can only be accessed via an internal 8-bit buffer, reading or writing to these register pairs must be carried out in a specific way. The important point to note is that data transfer to and from the 8-bit buffer and its related low byte only takes place when a write or read operation to its corresponding high byte is executed.

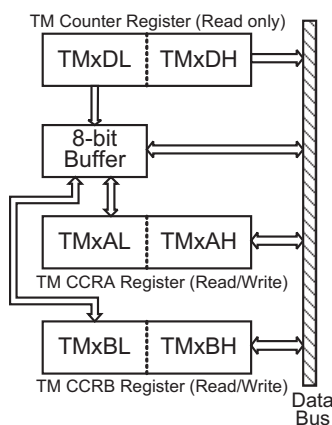

As the CCRA and CCRB registers are implemented in the way shown in the following diagram and accessing these register pairs is carried out in a specific way as described above, it is recommended to use the "MOV" instruction to access the CCRA and CCRB low byte registers, named TMxAL and TMxBL, using the following access procedures. Accessing the CCRA or CCRB low byte registers without following these access procedures will result in unpredictable values.

The following steps show the read and write procedures:

- Writing Data to CCRB or CCRA
 - ♦ Step 1. Write data to Low Byte TMxAL or TMxBL – note that here data is only written to the 8-bit buffer.
 - ♦ Step 2. Write data to High Byte TMxAH or TMxBH – here data is written directly to the high byte registers and simultaneously data is latched from the 8-bit buffer to the Low Byte registers.
- Reading Data from the Counter Registers and CCRB or CCRA
 - ♦ Step 1. Read data from the High Byte TMxDH, TMxAH or TMxBH – here data is read directly from the High Byte registers and simultaneously data is latched from the Low Byte register into the 8-bit buffer.
 - ♦ Step 2. Read data from the Low Byte TMxDL, TMxAL or TMxBL – this step reads data from the 8-bit buffer.

Compact Type TM – CTM

Although the simplest form of the three TM types, the Compact TM type still contains three operating modes, which are Compare Match Output, Timer/Event Counter and PWM Output modes. The Compact TM can also be controlled with an external input pin and can drive one or two external output pins. These two external output pins can be the same signal or the inverse signal.

CTM	Name	TM No.	TM Input Pin	TM Output Pin
HT66F13	—	—	—	—
HT66F14, HT66F15	10-bit CTM	0	TCK0	TP0_0, TP0_1

Compact TM Operation

At its core is a 10-bit count-up counter which is driven by a user selectable internal or external clock source. There are also two internal comparators with the names, Comparator A and Comparator P. These comparators will compare the value in the counter with CCRP and CCRA registers. The CCRP is three bits wide whose value is compared with the highest three bits in the counter while the CCRA is the ten bits and therefore compares with all counter bits.

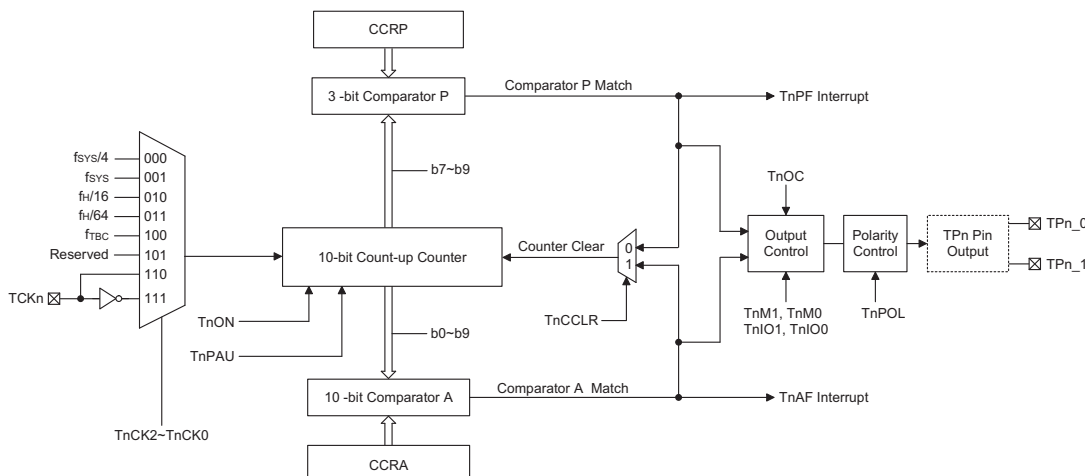

Compact Type TM Block Diagram

The only way of changing the value of the 10-bit counter using the application program, is to clear the counter by changing the TnON bit from low to high. The counter will also be cleared automatically by a counter overflow or a compare match with one of its associated comparators. When these conditions occur, a TM interrupt signal will also usually be generated. The Compact Type TM can operate in a number of different operational modes, can be driven by different clock sources including an input pin and can also control an output pin. All operating setup conditions are selected using relevant internal registers.

Compact Type TM Register Description

Overall operation of the Compact TM is controlled using six registers. A read only register pair exists to store the internal counter 10-bit value, while a read/write register pair exists to store the internal 10-bit CCRA value. The remaining two registers are control registers which setup the different operating and control modes as well as the three CCRP bits.

CTM Register List – HT66F14/HT66F15

Name	Bit7	Bit6	Bit5	Bit4	Bit3	Bit2	Bit1	Bit0
TM0C0	T0PAU	T0CK2	T0CK1	T0CK0	T0ON	T0RP2	T0RP1	T0RP0
TM0C1	T0M1	T0M0	T0IO1	T0IO0	T0OC	T0POL	T0DPX	T0CCLR
TM0DL	D7	D6	D5	D4	D3	D2	D1	D0
TM0DH	—	—	—	—	—	—	D9	D8
TM0AL	D7	D6	D5	D4	D3	D2	D1	D0
TM0AH	—	—	—	—	—	—	D9	D8

10-bit Compact TM Register List

TM0DL Register

Bit	7	6	5	4	3	2	1	0
Name	D7	D6	D5	D4	D3	D2	D1	D0
R/W	R	R	R	R	R	R	R	R
POR	0	0	0	0	0	0	0	0

Bit 7~0 **TM0DL**: TM0 Counter Low Byte Register bit 7 ~ bit 0
 TM0 10-bit Counter bit 7 ~ bit 0

TM0DH Register

Bit	7	6	5	4	3	2	1	0
Name	—	—	—	—	—	—	D9	D8
R/W	—	—	—	—	—	—	R	R
POR	—	—	—	—	—	—	0	0

Bit 7~2 Unimplemented, read as "0"
 Bit 1~0 **TM0DH**: TM0 Counter High Byte Register bit 1 ~ bit 0
 TM0 10-bit Counter bit 9 ~ bit 8

TM0AL Register

Bit	7	6	5	4	3	2	1	0
Name	D7	D6	D5	D4	D3	D2	D1	D0
R/W	R/W	R/W	R/W	R/W	R/W	R/W	R/W	R/W
POR	0	0	0	0	0	0	0	0

Bit 7~0 **TM0AL**: TM0 CCRA Low Byte Register bit 7 ~ bit 0
TM0 10-bit CCRA bit 7 ~ bit 0

TM0AH Register

Bit	7	6	5	4	3	2	1	0
Name	—	—	—	—	—	—	D9	D8
R/W	—	—	—	—	—	—	R/W	R/W
POR	—	—	—	—	—	—	0	0

Bit 7~2 Unimplemented, read as "0"
Bit 1~0 **TM0AH**: TM0 CCRA High Byte Register bit 1 ~ bit 0
TM0 10-bit CCRA bit 9 ~ bit 8

TM0C0 Register

Bit	7	6	5	4	3	2	1	0
Name	T0PAU	T0CK2	T0CK1	T0CK0	T0ON	T0RP2	T0RP1	T0RP0
R/W	R/W	R/W	R/W	R/W	R/W	R/W	R/W	R/W
POR	0	0	0	0	0	0	0	0

Bit 7 **T0PAU**: TM0 Counter Pause Control
0: run
1: pause
The counter can be paused by setting this bit high. Clearing the bit to zero restores normal counter operation. When in a Pause condition the TM will remain powered up and continue to consume power. The counter will retain its residual value when this bit changes from low to high and resume counting from this value when the bit changes to a low value again.

Bit 6~4 **T0CK2~T0CK0**: Select TM0 Counter clock
000: $f_{SYS}/4$
001: f_{SYS}
010: $f_H/16$
011: $f_H/64$
100: f_{RBC}
101: undefined
110: TCKn rising edge clock
111: TCKn falling edge clock
These three bits are used to select the clock source for the TM. Selecting the Reserved clock input will effectively disable the internal counter. The external pin clock source can be chosen to be active on the rising or falling edge. The clock source f_{SYS} is the system clock, while f_H and f_{RBC} are other internal clocks, the details of which can be found in the oscillator section.

Bit 3 **T0ON**: TM0 Counter On/Off Control
0: Off
1: On
This bit controls the overall on/off function of the TM. Setting the bit high enables the counter to run, clearing the bit disables the TM. Clearing this bit to zero will stop the counter from counting and turn off the TM which will reduce its power consumption. When the bit changes state from low to high the internal counter value will be reset to zero, however when the bit changes from high to low, the internal counter will retain its residual value.
If the TM is in the Compare Match Output Mode then the TM output pin will be reset to its initial condition, as specified by the T0OC bit, when the T0ON bit changes from low to high.

Bit 2~0 **TORP2~TORP0:** TM0 CCRP 3-bit register, compared with the TM0 Counter bit 9~bit 7
 Comparator P Match Period
 000: 1024 TM0 clocks
 001: 128 TM0 clocks
 010: 256 TM0 clocks
 011: 384 TM0 clocks
 100: 512 TM0 clocks
 101: 640 TM0 clocks
 110: 768 TM0 clocks
 111: 896 TM0 clocks

These three bits are used to setup the value on the internal CCRP 3-bit register, which are then compared with the internal counter's highest three bits. The result of this comparison can be selected to clear the internal counter if the T0CCLR bit is set to zero. Setting the T0CCLR bit to zero ensures that a compare match with the CCRP values will reset the internal counter. As the CCRP bits are only compared with the highest three counter bits, the compare values exist in 128 clock cycle multiples. Clearing all three bits to zero is in effect allowing the counter to overflow at its maximum value.

TM0C1 Register

Bit	7	6	5	4	3	2	1	0
Name	T0M1	T0M0	T0IO1	T0IO0	T0OC	T0POL	T0DPX	T0CCLR
R/W	R/W	R/W	R/W	R/W	R/W	R/W	R/W	R/W
POR	0	0	0	0	0	0	0	0

Bit 7~6 **T0M1~T0M0:** Select TM0 Operating Mode
 00: Compare Match Output Mode
 01: Undefined
 10: PWM Mode
 11: Timer/Counter Mode

These bits setup the required operating mode for the TM. To ensure reliable operation the TM should be switched off before any changes are made to the T0M1 and T0M0 bits. In the Timer/Counter Mode, the TM output pin control must be disabled.

Bit 5~4 **T0IO1~T0IO0:** Select TP0_0, TP0_1 output function
 Compare Match Output Mode
 00: No change
 01: Output low
 10: Output high
 11: Toggle output
 PWM Mode
 00: PWM output inactive state
 01: PWM output active state
 10: PWM output
 11: Undefined
 Timer/counter Mode
 unused

These two bits are used to determine how the TM output pin changes state when a certain condition is reached. The function that these bits select depends upon in which mode the TM is running.

In the Compare Match Output Mode, the T0IO1 and T0IO0 bits determine how the TM output pin changes state when a compare match occurs from the Comparator A. The TM output pin can be setup to switch high, switch low or to toggle its present state when a compare match occurs from the Comparator A. When the bits are both zero, then no change will take place on the output. The initial value of the TM output pin should be setup using the T0OC bit in the TM0C1 register. Note that the output level requested by the T0IO1 and T0IO0 bits must be different from the initial value setup using the T0OC bit otherwise no change will occur on the TM output pin when a compare match occurs. After the TM output pin changes state it can be reset to its initial level by changing the level of the T0ON bit from low to high.

In the PWM Mode, the T0IO1 and T0IO0 bits determine how the TM output pin changes state when a certain compare match condition occurs. The PWM output function is modified by changing these two bits. It is necessary to change the values of the T0IO1 and T0IO0 bits only after the TMn has been switched off. Unpredictable PWM outputs will occur if the T0IO1 and T0IO0 bits are changed when the TM is running

- Bit 3 **T0OC**: TP0_0, TP0_1 output control bit
Compare Match Output Mode
0: Initial low
1: Initial high
PWM Mode
0: Active low
1: Active high
This is the output control bit for the TM output pin. Its operation depends upon whether TM is being used in the Compare Match Output Mode or in the PWM Mode. It has no effect if the TM is in the Timer/Counter Mode. In the Compare Match Output Mode it determines the logic level of the TM output pin before a compare match occurs. In the PWM Mode it determines if the PWM signal is active high or active low.
- Bit 2 **T0POL**: TP0_0, TP0_1 output polarity control
0: Non-invert
1: Invert
This bit controls the polarity of the TP0_0 or TP0_1 output pin. When the bit is set high the TM output pin will be inverted and not inverted when the bit is zero. It has no effect if the TM is in the Timer/Counter Mode.
- Bit 1 **T0DPX**: TM0 PWM period/duty Control
0: CCRP - period; CCRA - duty
1: CCRP - duty; CCRA - period
This bit, determines which of the CCRA and CCRP registers are used for period and duty control of the PWM waveform.
- Bit 0 **T0CCLR**: Select TM0 Counter clear condition
0: TM0 Comparatror P match
1: TM0 Comparatror A match
This bit is used to select the method which clears the counter. Remember that the Compact TM contains two comparators, Comparator A and Comparator P, either of which can be selected to clear the internal counter. With the T0CCLR bit set high, the counter will be cleared when a compare match occurs from the Comparator A. When the bit is low, the counter will be cleared when a compare match occurs from the Comparator P or with a counter overflow. A counter overflow clearing method can only be implemented if the CCRP bits are all cleared to zero. The T0CCLR bit is not used in the PWM Mode.

Compact Type TM Operating Modes

The Compact Type TM can operate in one of three operating modes, Compare Match Output Mode, PWM Mode or Timer/Counter Mode. The operating mode is selected using the TnM1 and TnM0 bits in the TMnC1 register.

Compare Match Output Mode

To select this mode, bits TnM1 and TnM0 in the TMnC1 register, should be set to 00B respectively. In this mode once the counter is enabled and running it can be cleared by three methods. These are a counter overflow, a compare match from Comparator A and a compare match from Comparator P. When the TnCCLR bit is low, there are two ways in which the counter can be cleared. One is when a compare match occurs from Comparator P, the other is when the CCRP bits are all zero which allows the counter to overflow. Here both TnAF and TnPF interrupt request flags for the Comparator A and Comparator P respectively, will both be generated.

If the TnCCLR bit in the TMnC1 register is high then the counter will be cleared when a compare match occurs from Comparator A. However, here only the TnAF interrupt request flag will be generated even if the value of the CCRP bits is less than that of the CCRA registers. Therefore when TnCCLR is high no TnPF interrupt request flag will be generated. If the CCRA bits are all zero, the counter will overflow when it reaches its maximum 10-bit, 3FF Hex, value, however here the TnAF interrupt request flag will not be generated.

As the name of the mode suggests, after a comparison is made, the TM output pin will change state. The TM output pin condition however only changes state when a TnAF interrupt request flag is generated after a compare match occurs from Comparator A. The TnPF interrupt request flag, generated from a compare match occurs from Comparator P, will have no effect on the TM output pin. The way in which the TM output pin changes state are determined by the condition of the TnIO1 and TnIO0 bits in the TMnC1 register. The TM output pin can be selected using the TnIO1 and TnIO0 bits to go high, to go low or to toggle from its present condition when a compare match occurs from Comparator A. The initial condition of the TM output pin, which is setup after the TnON bit changes from low to high, is setup using the TnOC bit. Note that if the TnIO1 and TnIO0 bits are zero then no pin change will take place.

Timer/Counter Mode

To select this mode, bits TnM1 and TnM0 in the TMnC1 register should be set to 11 respectively. The Timer/Counter Mode operates in an identical way to the Compare Match Output Mode generating the same interrupt flags. The exception is that in the Timer/Counter Mode the TM output pin is not used. Therefore the above description and Timing Diagrams for the Compare Match Output Mode can be used to understand its function. As the TM output pin is not used in this mode, the pin can be used as a normal I/O pin or other pin-shared function.

PWM Output Mode

To select this mode, bits TnM1 and TnM0 in the TMnC1 register should be set to 10 respectively. The PWM function within the TM is useful for applications which require functions such as motor control, heating control, illumination control etc. By providing a signal of fixed frequency but of varying duty cycle on the TM output pin, a square wave AC waveform can be generated with varying equivalent DC RMS values.

As both the period and duty cycle of the PWM waveform can be controlled, the choice of generated waveform is extremely flexible. In the PWM mode, the TnCCLR bit has no effect on the PWM operation. Both of the CCRA and CCRP registers are used to generate the PWM waveform, one register is used to clear the internal counter and thus control the PWM waveform frequency, while the other one is used to control the duty cycle. Which register is used to control either frequency or duty cycle is determined using the TnDPX bit in the TMnC1 register. The PWM waveform frequency and duty cycle can therefore be controlled by the values in the CCRA and CCRP registers.

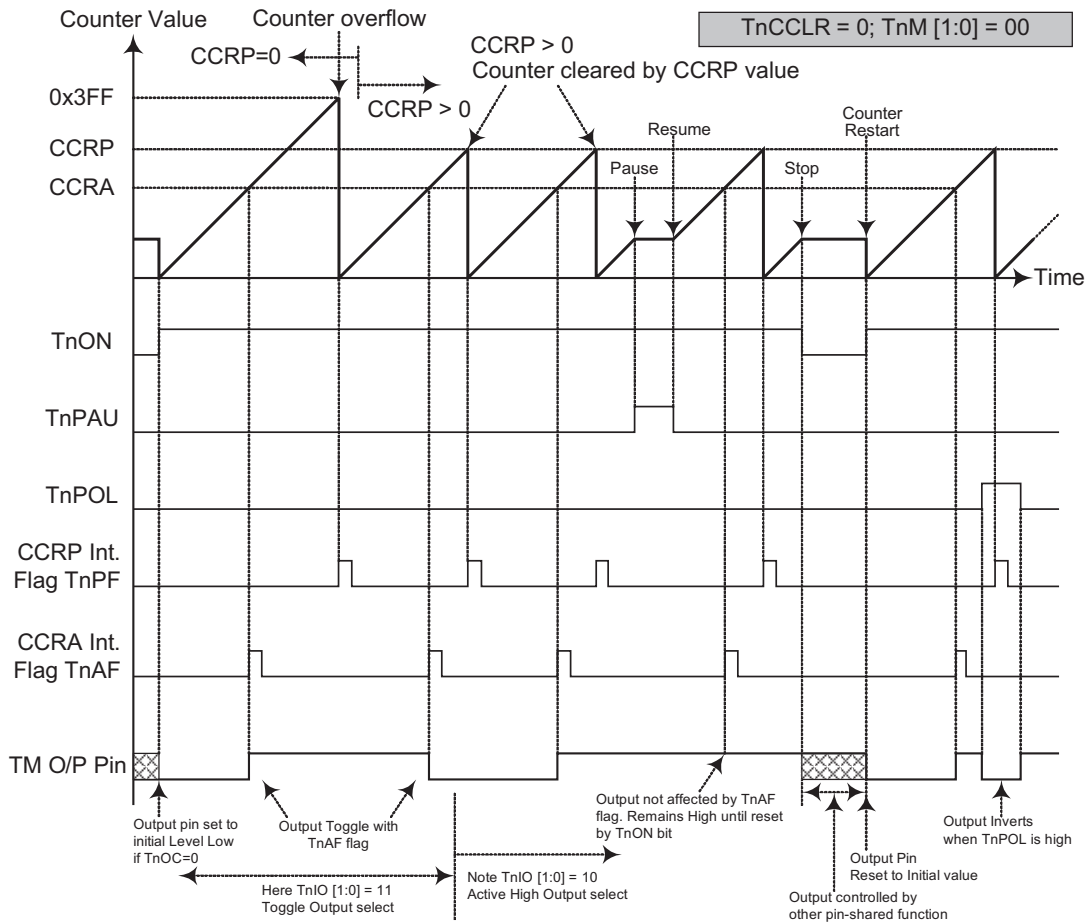

Compare Match Output Mode -- TnCCLR = 0

- Note:
1. With $TnCCLR=0$, a Comparator P match will clear the counter
 2. The TM output pin is controlled only by the TnAF flag
 3. The output pin is reset to its initial state by a TnON bit rising edge

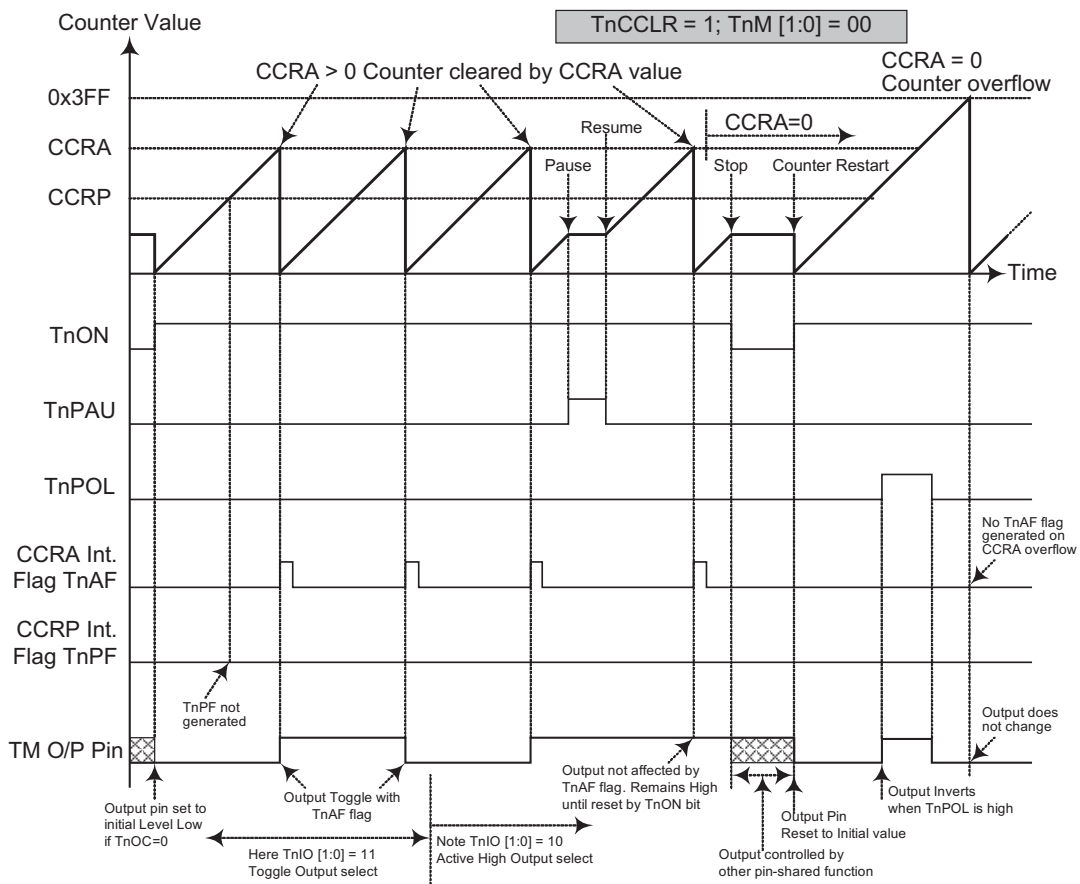

Compare Match Output Mode -- TnCCLR = 1

- Note:
1. With $TnCCLR=1$, a Comparator A match will clear the counter
 2. The TM output pin is controlled only by the TnAF flag
 3. The output pin is reset to its initial state by a TnON bit rising edge
 4. The TnPF flag is not generated when $TnCCLR=1$

An interrupt flag, one for each of the CCRA and CCRP, will be generated when a compare match occurs from either Comparator A or Comparator P. The TnOC bit in the TMnC1 register is used to select the required polarity of the PWM waveform while the two TnIO1 and TnIO0 bits are used to enable the PWM output or to force the TM output pin to a fixed high or low level. The TnPOL bit is used to reverse the polarity of the PWM output waveform.

- CTM, PWM Mode, Edge-aligned Mode, T0DPX=0

CCRP	001b	010b	011b	100b	101b	110b	111b	000b
Period	128	256	384	512	640	768	896	1024
Duty	CCRA							

If $f_{SYS} = 16\text{MHz}$, TM clock source is $f_{SYS}/4$, CCRP = 100b and CCRA = 128,
 The CTM PWM output frequency = $(f_{SYS}/4) / 512 = f_{SYS}/2048 = 7.8125\text{ kHz}$, duty = $128/512 = 25\%$.
 If the Duty value defined by the CCRA register is equal to or greater than the Period value, then the PWM output duty is 100%.

- CTM, PWM Mode, Edge-aligned Mode, T0DPX=1

CCRP	001b	010b	011b	100b	101b	110b	111b	000b
Period	CCRA							
Duty	128	256	384	512	640	768	896	1024

The PWM output period is determined by the CCRA register value together with the TM clock while the PWM duty cycle is defined by the CCRP register value.

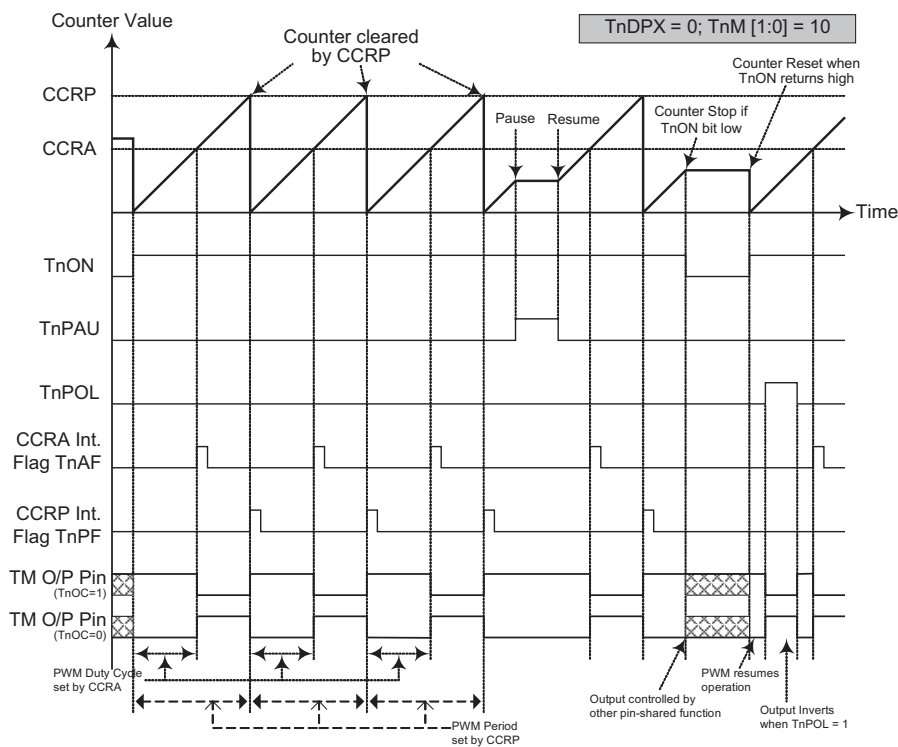

- Note:
1. Here TnDPX=0 -- Counter cleared by CCRP
 2. A counter clear sets the PWM Period
 3. The internal PWM function continues even when TnIO [1:0] = 00 or 01
 4. The TnCLR bit has no influence on PWM operation

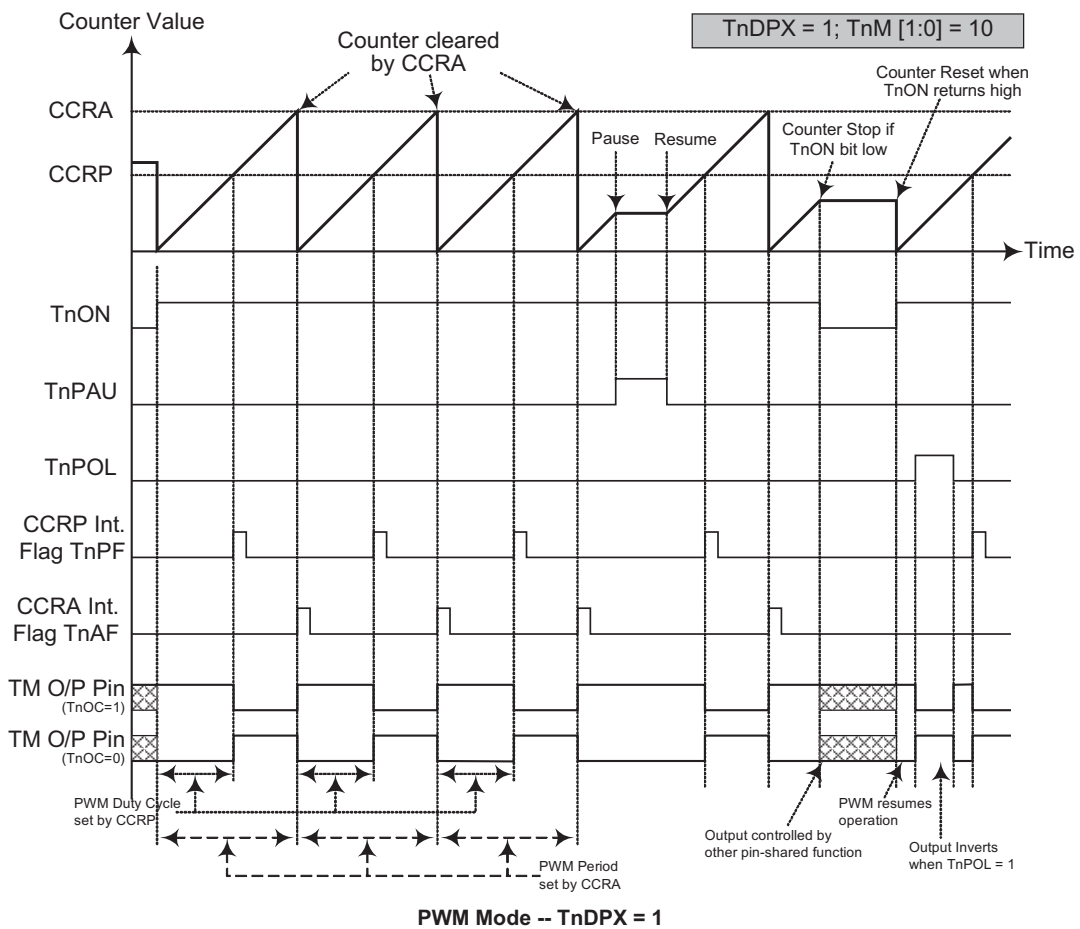

- Note:
1. Here TnDPX = 1 -- Counter cleared by CCRA
 2. A counter clear sets the PWM Period
 3. The internal PWM function continues even when TnIO [1:0] = 00 or 01
 4. The TnCCLR bit has no influence on PWM operation

Standard Type TM – STM

The Standard Type TM contains five operating modes, which are Compare Match Output, Timer/Event Counter, Capture Input, Single Pulse Output and PWM Output modes. The Standard TM can also be controlled with an external input pin and can drive one or two external output pins.

CTM	Name	TM No.	TM Input Pin	TM Output Pin
HT66F13/HT66F14	10-bit STM	1	TCK1	TP1_0, TP1_1
HT66F15	—	—	—	—

Standard TM Operation

At its core is a 10-bit count-up counter which is driven by a user selectable internal or external clock source. There are also two internal comparators with the names, Comparator A and Comparator P. These comparators will compare the value in the counter with CCRP and CCRA registers. The CCRP is three bits wide whose value is compared with the highest three bits in the counter while the CCRA is the ten bits and therefore compares with all counter bits.

The only way of changing the value of the 10-bit counter using the application program, is to clear the counter by changing the TnON bit from low to high. The counter will also be cleared automatically by a counter overflow or a compare match with one of its associated comparators. When these conditions occur, a TM interrupt signal will also usually be generated. The Standard Type TM can operate in a number of different operational modes, can be driven by different clock sources including an input pin and can also control an output pin. All operating setup conditions are selected using relevant internal registers.

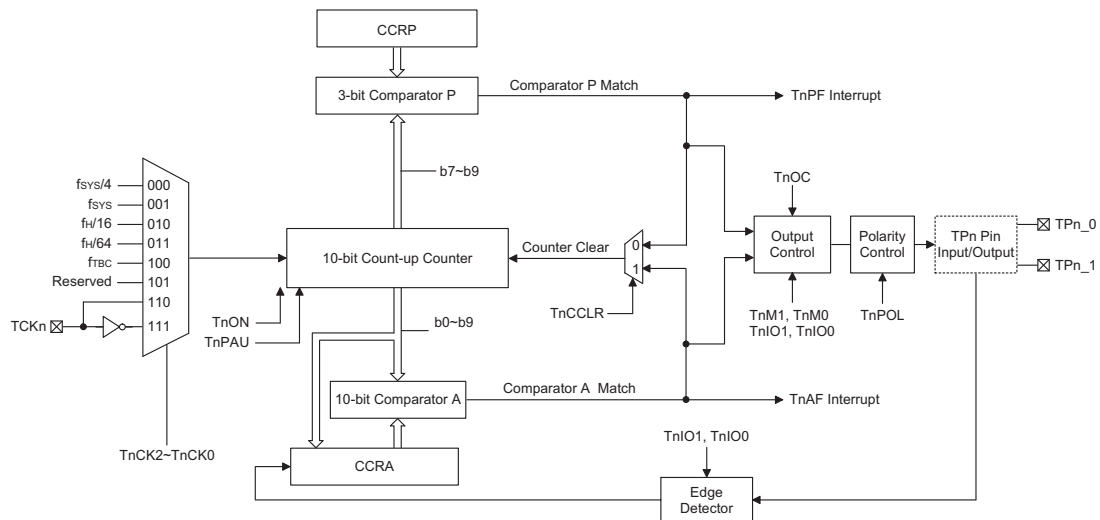

Standard Type TM Block Diagram

Standard Type TM Register Description

Overall operation of the Standard TM is controlled using a series of registers. A read only register pair exists to store the internal counter 10-bit value, while a read/write register pair exists to store the internal 10-bit CCRA value. The remaining two registers are control registers which setup the different operating and control modes as well as the three CCRP bits.

STM Register List – HT66F13/ HT66F14

Name	Bit7	Bit6	Bit5	Bit4	Bit3	Bit2	Bit1	Bit0
TM1C0	T1PAU	T1CK2	T1CK1	T1CK0	T1ON	T1RP2	T1RP1	T1RP0
TM1C1	T1M1	T1M0	T1IO1	T1IO0	T1OC	T1POL	T1DPX	T1CCLR
TM1DL	D7	D6	D5	D4	D3	D2	D1	D0
TM1DH	—	—	—	—	—	—	D9	D8
TM1AL	D7	D6	D5	D4	D3	D2	D1	D0
TM1AH	—	—	—	—	—	—	D9	D8

10-bit Standard TM Register List

TM1C0 Register

Bit	7	6	5	4	3	2	1	0
Name	T1PAU	T1CK2	T1CK1	T1CK0	T1ON	T1RP2	T1RP1	T1RP0
R/W	R/W	R/W	R/W	R/W	R/W	R/W	R/W	R/W
POR	0	0	0	0	0	0	0	0

- Bit 7** **T1PAU:** TM1 Counter Pause Control
0: run
1: pause
The counter can be paused by setting this bit high. Clearing the bit to zero restores normal counter operation. When in a Pause condition the TM will remain powered up and continue to consume power. The counter will retain its residual value when this bit changes from low to high and resume counting from this value when the bit changes to a low value again.
- Bit 6~4** **T1CK2~T1CK0:** Select TM1 Counter clock
000: $f_{SYS}/4$
001: f_{SYS}
010: $f_H/16$
011: $f_H/64$
100: f_{TBC}
101: undefined
110: TCK1 rising edge clock
111: TCK1 falling edge clock
These three bits are used to select the clock source for the TM. Selecting the Reserved clock input will effectively disable the internal counter. The external pin clock source can be chosen to be active on the rising or falling edge. The clock source f_{SYS} is the system clock, while f_H and f_{TBC} are other internal clocks, the details of which can be found in the oscillator section.
- Bit 3** **T1ON:** TM1 Counter On/Off Control
0: Off
1: On
This bit controls the overall on/off function of the TM. Setting the bit high enables the counter to run, clearing the bit disables the TM. Clearing this bit to zero will stop the counter from counting and turn off the TM which will reduce its power consumption. When the bit changes state from low to high the internal counter value will be reset to zero, however when the bit changes from high to low, the internal counter will retain its residual value until the bit returns high again.
If the TM is in the Compare Match Output Mode then the TM output pin will be reset to its initial condition, as specified by the T1OC bit, when the T1ON bit changes from low to high.

Bit 2~0 **T1RP2~T1RP0:** TM1 CCRP 3-bit register, compared with the TM1 Counter bit 9~bit 7
 Comparator P Match Period
 000: 1024 TM1 clocks
 001: 128 TM1 clocks
 010: 256 TM1 clocks
 011: 384 TM1 clocks
 100: 512 TM1 clocks
 101: 640 TM1 clocks
 110: 768 TM1 clocks
 111: 896 TM1 clocks

These three bits are used to setup the value on the internal CCRP 3-bit register, which are then compared with the internal counter's highest three bits. The result of this comparison can be selected to clear the internal counter if the T1CCLR bit is set to zero. Setting the T1CCLR bit to zero ensures that a compare match with the CCRP values will reset the internal counter. As the CCRP bits are only compared with the highest three counter bits, the compare values exist in 128 clock cycle multiples. Clearing all three bits to zero is in effect allowing the counter to overflow at its maximum value.

TM1C1 Register

Bit	7	6	5	4	3	2	1	0
Name	T1M1	T1M0	T1IO1	T1IO0	T1OC	T1POL	T1DPX	T1CCLR
R/W	R/W	R/W	R/W	R/W	R/W	R/W	R/W	R/W
POR	0	0	0	0	0	0	0	0

Bit 7~6 **T1M1~T1M0:** Select TM1 Operating Mode
 00: Compare Match Output Mode
 01: Capture Input Mode
 10: PWM Mode or Single Pulse Output Mode
 11: Timer/Counter Mode

These bits setup the required operating mode for the TM. To ensure reliable operation the TM should be switched off before any changes are made to the T1M1 and T1M0 bits. In the Timer/Counter Mode, the TM output pin control must be disabled.

Bit 5~4 **T1IO1~T1IO0:** Select TP1_0, TP1_1 output function
 Compare Match Output Mode
 00: No change
 01: Output low
 10: Output high
 11: Toggle output
 PWM Mode/Single Pulse Output Mode
 00: PWM output inactive state
 01: PWM output active state
 10: PWM output
 11: Single pulse output
 Capture Input Mode
 00: Input capture at rising edge of TP1_0, TP1_1
 01: Input capture at falling edge of TP1_0, TP1_1
 10: Input capture at falling/rising edge of TP1_0, TP1_1
 11: Input capture disabled
 Timer/counter Mode:
 Unused

These two bits are used to determine how the TM output pin changes state when a certain condition is reached. The function that these bits select depends upon in which mode the TM is running.

In the Compare Match Output Mode, the T1IO1 and T1IO0 bits determine how the TM output pin changes state when a compare match occurs from the Comparator A. The TM output pin can be setup to switch high, switch low or to toggle its present state when a compare match occurs from the Comparator A. When the bits are both zero, then no change will take place on the output. The initial value of the TM output pin should be setup using the T1OC bit in the TM1C1 register. Note that the output level requested by the T1IO1 and T1IO0 bits must be different from

the initial value setup using the T1OC bit otherwise no change will occur on the TM output pin when a compare match occurs. After the TM output pin changes state it can be reset to its initial level by changing the level of the T1ON bit from low to high.

In the PWM Mode, the T1IO1 and T1IO0 bits determine how the TM output pin changes state when a certain compare match condition occurs. The PWM output function is modified by changing these two bits. It is necessary to change the values of the T1IO1 and T1IO0 bits only after the TM has been switched off. Unpredictable PWM outputs will occur if the T1IO1 and T1IO0 bits are changed when the TM is running

- Bit 3 **T1OC**: TP1_0, TP1_1 Output control bit
Compare Match Output Mode
0: initial low
1: initial high
PWM Mode/ Single Pulse Output Mode
0: Active low
1: Active high
This is the output control bit for the TM output pin. Its operation depends upon whether TM is being used in the Compare Match Output Mode or in the PWM Mode/ Single Pulse Output Mode. It has no effect if the TM is in the Timer/Counter Mode. In the Compare Match Output Mode it determines the logic level of the TM output pin before a compare match occurs. In the PWM Mode it determines if the PWM signal is active high or active low.
- Bit 2 **T1POL**: TP1_0, TP1_1 Output polarity Control
0: non-invert
1: invert
This bit controls the polarity of the TP1_0 or TP1_1 output pin. When the bit is set high the TM output pin will be inverted and not inverted when the bit is zero. It has no effect if the TM is in the Timer/Counter Mode.
- Bit 1 **T1DPX**: TM1 PWM period/duty Control
0: CCRP - period; CCRA - duty
1: CCRP - duty; CCRA - period
This bit, determines which of the CCRA and CCRP registers are used for period and duty control of the PWM waveform.
- Bit 0 **T1CCLR**: Select TM1 Counter clear condition
0: TM1 Comparatr P match
1: TM1 Comparatr A match
This bit is used to select the method which clears the counter. Remember that the Standard TM contains two comparators, Comparator A and Comparator P, either of which can be selected to clear the internal counter. With the T1CCLR bit set high, the counter will be cleared when a compare match occurs from the Comparator A. When the bit is low, the counter will be cleared when a compare match occurs from the Comparator P or with a counter overflow. A counter overflow clearing method can only be implemented if the CCRP bits are all cleared to zero. The T1CCLR bit is not used in the PWM, Single Pulse or Input Capture Mode.

TM1DL Register

Bit	7	6	5	4	3	2	1	0
Name	D7	D6	D5	D4	D3	D2	D1	D0
R/W	R	R	R	R	R	R	R	R
POR	0	0	0	0	0	0	0	0

Bit 7~0 **TM1DL**: TM1 Counter Low Byte Register bit 7~bit 0
 TM1 10-bit Counter bit 7~bit 0

TM1DH Register

Bit	7	6	5	4	3	2	1	0
Name	—	—	—	—	—	—	D9	D8
R/W	—	—	—	—	—	—	R	R
POR	—	—	—	—	—	—	0	0

Bit 7~2 Unimplemented, read as "0"
 Bit 1~0 **TM1DH**: TM1 Counter High Byte Register bit 1~bit 0
 TM1 10-bit Counter bit 9~bit 8

TM1AL Register

Bit	7	6	5	4	3	2	1	0
Name	D7	D6	D5	D4	D3	D2	D1	D0
R/W	R/W	R/W	R/W	R/W	R/W	R/W	R/W	R/W
POR	0	0	0	0	0	0	0	0

Bit 7~0 **TM1AL**: TM1 CCRA Low Byte Register bit 7~bit 0
 TM1 10-bit CCRA bit 7~bit 0

TM1AH Register

Bit	7	6	5	4	3	2	1	0
Name	—	—	—	—	—	—	D9	D8
R/W	—	—	—	—	—	—	R/W	R/W
POR	—	—	—	—	—	—	0	0

Bit 7~2 Unimplemented, read as "0"
 Bit 1~0 **TM1AH**: TM1 CCRA High Byte Register bit 1~bit 0
 TM1 10-bit CCRA bit 9~bit 8

Standard Type TM Operating Modes

The Standard Type TM can operate in one of five operating modes, Compare Match Output Mode, PWM Mode, Single Pulse Output Mode, Capture Input Mode or Timer/Counter Mode. The operating mode is selected using the TnM1 and TnM0 bits in the TMnC1 register.

Compare Match Output Mode

To select this mode, bits TnM1 and TnM0 in the TMnC1 register, should be set to 00 respectively. In this mode once the counter is enabled and running it can be cleared by three methods. These are a counter overflow, a compare match from Comparator A and a compare match from Comparator P. When the TnCCLR bit is low, there are two ways in which the counter can be cleared. One is when a compare match from Comparator P, the other is when the CCRP bits are all zero which allows the counter to overflow. Here both TnAF and TnPF interrupt request flags for Comparator A and Comparator P respectively, will both be generated.

If the TnCCLR bit in the TMnC1 register is high then the counter will be cleared when a compare match occurs from Comparator A. However, here only the TnAF interrupt request flag will be generated even if the value of the CCRP bits is less than that of the CCRA registers. Therefore when TnCCLR is high no TnPF interrupt request flag will be generated. In the Compare Match Output Mode, the CCRA can not be set to 0.

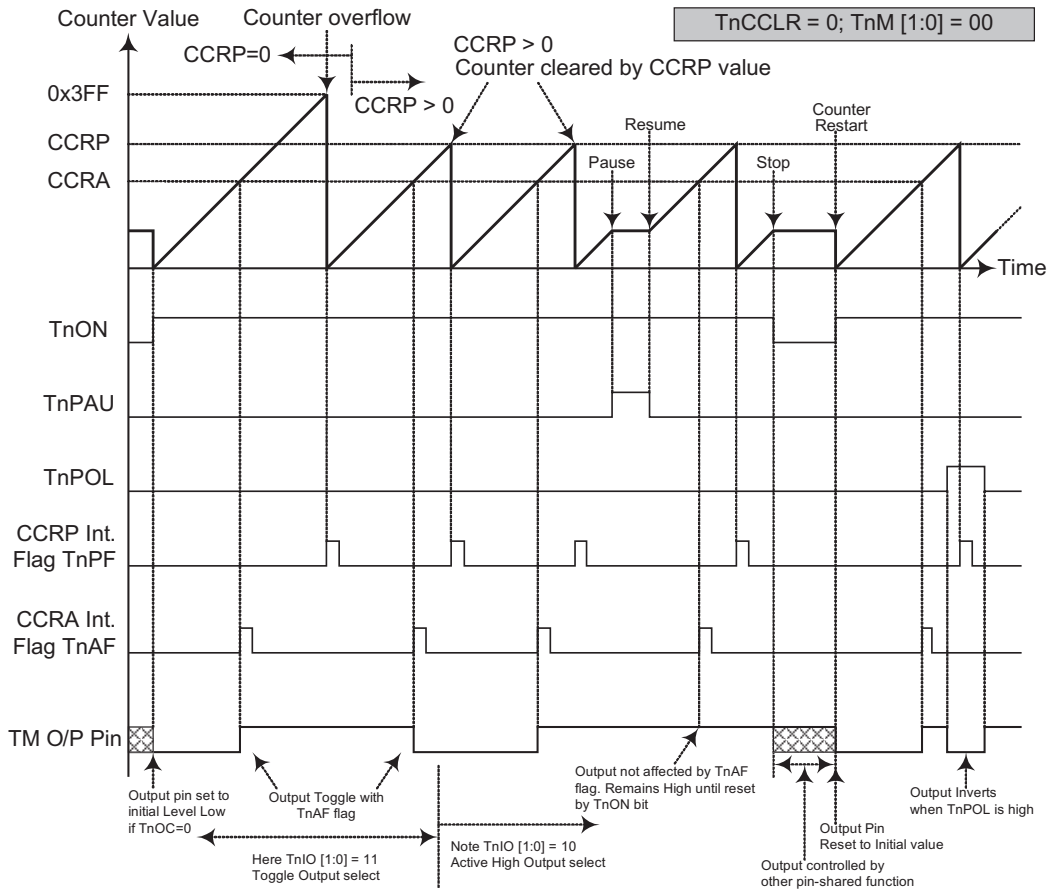

Compare Match Output Mode -- TnCCLR = 0

- Note:
1. With TnCCLR=0 a Comparator P match will clear the counter
 2. The TM output pin is controlled only by the TnAF flag
 3. The output pin is reset to its initial state by a TnON bit rising edge

As the name of the mode suggests, after a comparison is made, the TM output pin, will change state. The TM output pin condition however only changes state when a TnAF interrupt request flag is generated after a compare match occurs from Comparator A. The TnPF interrupt request flag, generated from a compare match occurs from Comparator P, will have no effect on the TM output pin. The way in which the TM output pin changes state are determined by the condition of the TnIO1 and TnIO0 bits in the TMnC1 register. The TM output pin can be selected using the TnIO1 and TnIO0 bits to go high, to go low or to toggle from its present condition when a compare match occurs from Comparator A. The initial condition of the TM output pin, which is setup after the TnON bit changes from low to high, is setup using the TnOC bit. Note that if the TnIO1 and TnIO0 bits are zero then no pin change will take place.

Timer/Counter Mode

To select this mode, bits TnM1 and TnM0 in the TMnC1 register should be set to 11 respectively. The Timer/Counter Mode operates in an identical way to the Compare Match Output Mode generating the same interrupt flags. The exception is that in the Timer/Counter Mode the TM output pin is not used. Therefore the above description and Timing Diagrams for the Compare Match Output Mode can be used to understand its function. As the TM output pin is not used in this mode, the pin can be used as a normal I/O pin or other pin-shared function.

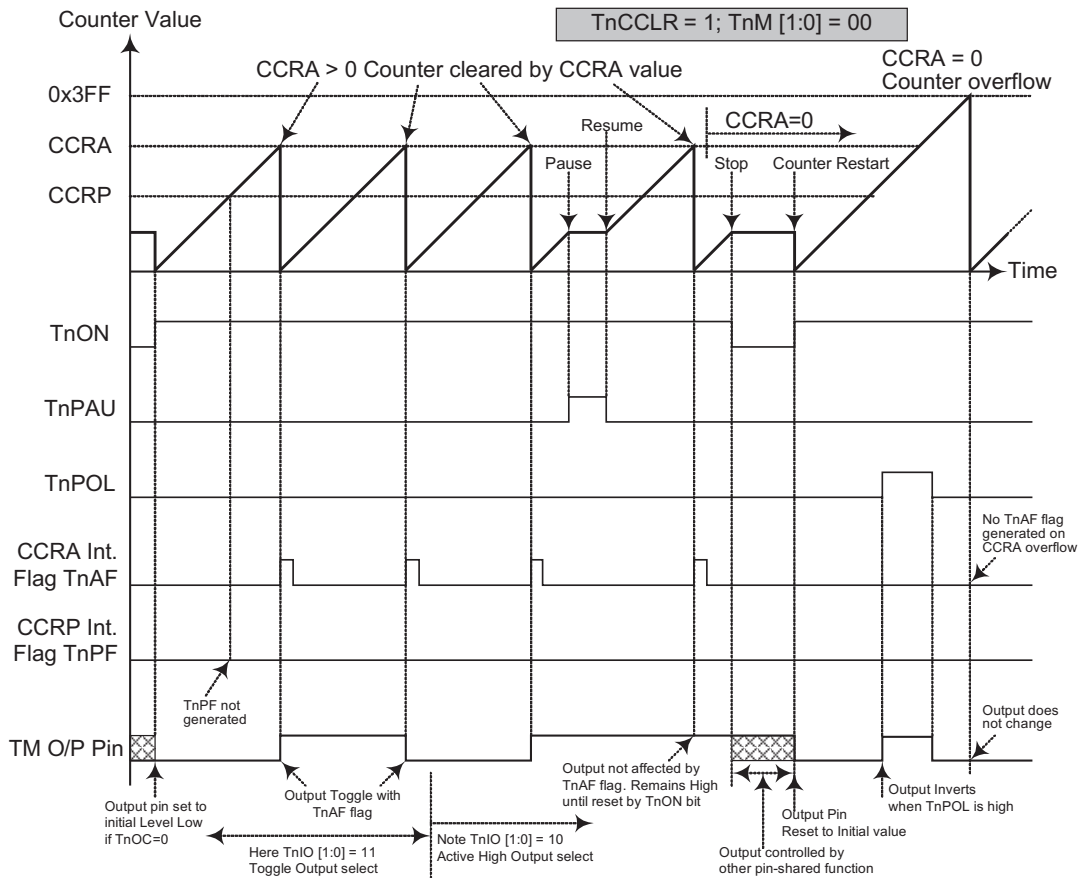

Compare Match Output Mode -- TnCCLR = 1

- Note:
1. With TnCCLR=1 a Comparator A match will clear the counter
 2. The TM output pin is controlled only by the TnAF flag
 3. The output pin is reset to its initial state by a TnON bit rising edge
 4. A TnPF flag is not generated when TnCCLR=1

PWM Output Mode

To select this mode, bits TnM1 and TnM0 in the TMnC1 register should be set to 10 respectively. The PWM function within the TM is useful for applications which require functions such as motor control, heating control, illumination control etc. By providing a signal of fixed frequency but of varying duty cycle on the TM output pin, a square wave AC waveform can be generated with varying equivalent DC RMS values.

As both the period and duty cycle of the PWM waveform can be controlled, the choice of generated waveform is extremely flexible. In the PWM mode, the TnCCLR bit has no effect on the PWM operation. Both of the CCRA and CCRP registers are used to generate the PWM waveform, one register is used to clear the internal counter and thus control the PWM waveform frequency, while the other one is used to control the duty cycle. Which register is used to control either frequency or duty cycle is determined using the TnDPX bit in the TMnC1 register. The PWM waveform frequency and duty cycle can therefore be controlled by the values in the CCRA and CCRP registers.

An interrupt flag, one for each of the CCRA and CCRP, will be generated when a compare match occurs from either Comparator A or Comparator P. The TnOC bit in the TMnC1 register is used to select the required polarity of the PWM waveform while the two TnIO1 and TnIO0 bits are used to enable the PWM output or to force the TM output pin to a fixed high or low level. The TnPOL bit is used to reverse the polarity of the PWM output waveform.

- STM, PWM Mode, Edge-aligned Mode, T0DPX=0

CCRP	001b	010b	011b	100b	101b	110b	111b	000b
Period	128	256	384	512	640	768	896	1024
Duty	CCRA							

If $f_{SYS} = 16\text{MHz}$, TM clock source is $f_{SYS}/4$, CCRP = 100b and CCRA =128,
 The STM PWM output frequency = $(f_{SYS}/4) / 512 = f_{SYS}/2048 = 7.8125\text{ kHz}$, duty = $128/512 = 25\%$.
 If the Duty value defined by the CCRA register is equal to or greater than the Period value, then the PWM output duty is 100%.

- STM, PWM Mode, Edge-aligned Mode, T0DPX=1

CCRP	001b	010b	011b	100b	101b	110b	111b	000b
Period	CCRA							
Duty	128	256	384	512	640	768	896	1024

The PWM output period is determined by the CCRA register value together with the TM clock while the PWM duty cycle is defined by the CCRP register value.

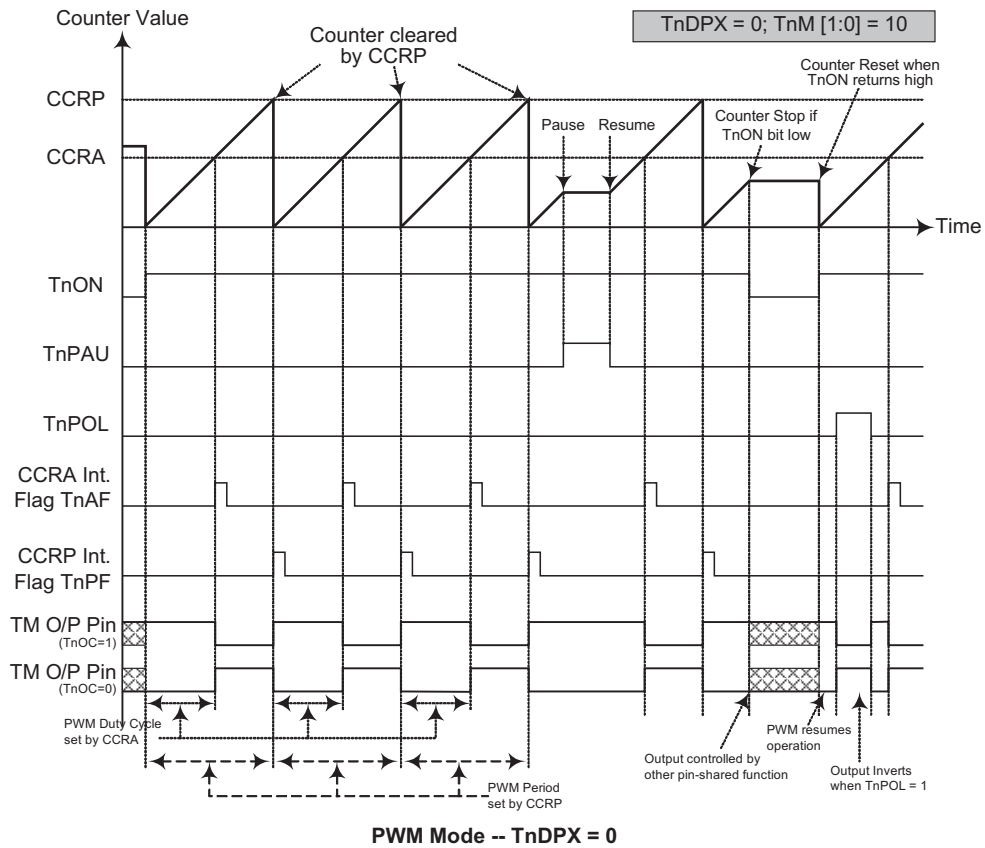

- Note:
1. Here TnDPX=0 -- Counter cleared by CCRP
 2. A counter clear sets the PWM Period
 3. The internal PWM function continues running even when TnIO [1:0] = 00 or 01
 4. The TnCCLR bit has no influence on PWM operation

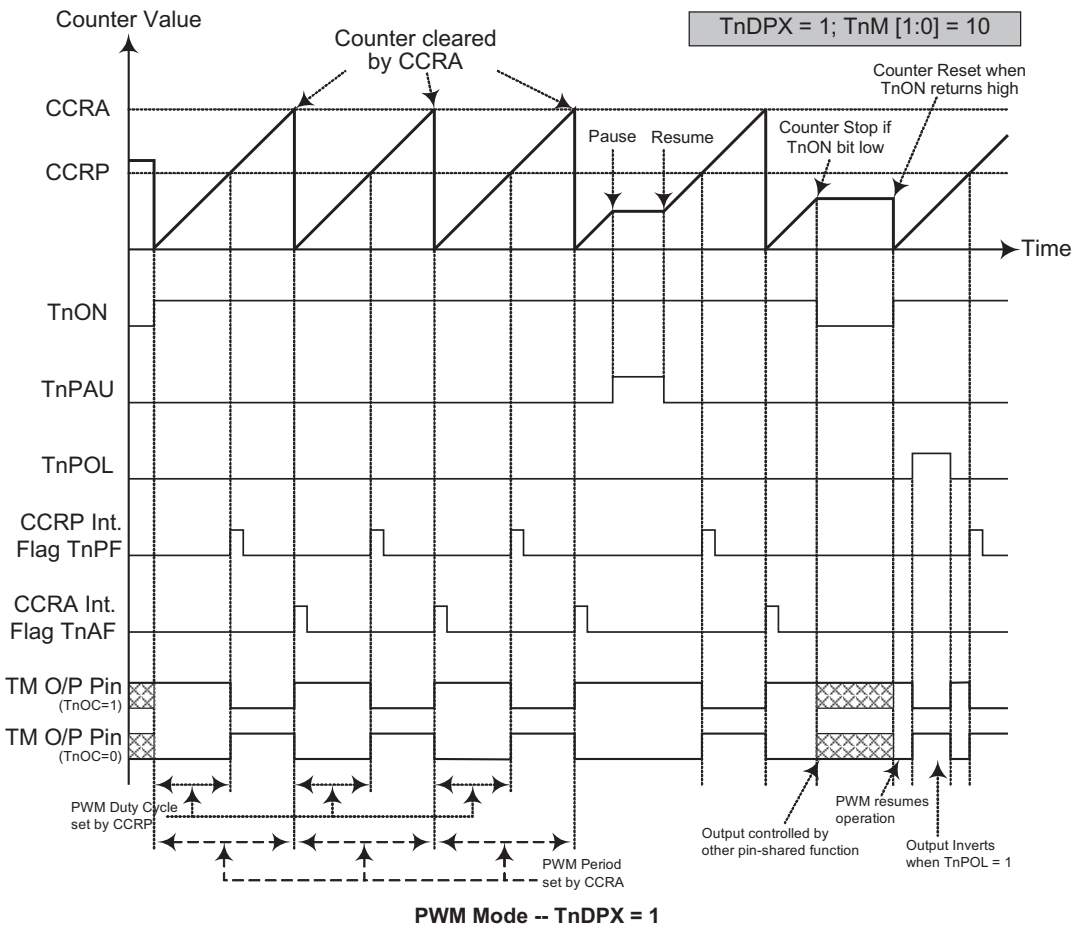

- Note:
1. Here TnDPX=1 -- Counter cleared by CCRA
 2. A counter clear sets the PWM Period
 3. The internal PWM function continues even when TnIO [1:0] = 00 or 01
 4. The TnCCLR bit has no influence on PWM operation

Single Pulse Mode

To select this mode, bits TnM1 and TnM0 in the TMnC1 register should be set to 10 respectively and also the TnIO1 and TnIO0 bits should be set to 11 respectively. The Single Pulse Output Mode, as the name suggests, will generate a single shot pulse on the TM output pin.

The trigger for the pulse output leading edge is a low to high transition of the TnON bit, which can be implemented using the application program. However in the Single Pulse Mode, the TnON bit can also be made to automatically change from low to high using the external TCKn pin, which will in turn initiate the Single Pulse output. When the TnON bit transitions to a high level, the counter will start running and the pulse leading edge will be generated. The TnON bit should remain high when the pulse is in its active state. The generated pulse trailing edge will be generated when the TnON bit is cleared to zero, which can be implemented using the application program or when a compare match occurs from Comparator A.

Capture Input Mode

To select this mode bits TnM1 and TnM0 in the TMnC1 register should be set to 01 respectively. This mode enables external signals to capture and store the present value of the internal counter and can therefore be used for applications such as pulse width measurements. The external signal is supplied on the TPn_0 or TPn_1 pin, whose active edge can be either a rising edge, a falling edge or both rising and falling edges; the active edge transition type is selected using the TnIO1 and TnIO0 bits in the TMnC1 register. The counter is started when the TnON bit changes from low to high which is initiated using the application program.

When the required edge transition appears on the TPn_0 or TPn_1 pin, the present value in the counter will be latched into the CCRA registers and a TM interrupt generated. Irrespective of what events occur on the TPn_0 or TPn_1 pin the counter will continue to free run until the TnON bit changes from high to low. When a CCRP compare match occurs, the counter will reset back to zero; in this way the CCRP value can be used to control the maximum counter value. When a CCRP compare match occurs from Comparator P, a TM interrupt will also be generated. Counting the number of overflow interrupt signals from the CCRP can be a useful method in measuring long pulse widths. The TnIO1 and TnIO0 bits can select the active trigger edge on the TPn_0 or TPn_1 pin to be a rising edge, falling edge or both edge types. If the TnIO1 and TnIO0 bits are both set high, then no capture operation will take place irrespective of what happens on the TPn_0 or TPn_1 pin, however it must be noted that the counter will continue to run.

As the TPn_0 or TPn_1 pin is pin shared with other functions, care must be taken if the TM is in the Input Capture Mode. This is because if the pin is setup as an output, then any transitions on this pin may cause an input capture operation to be executed. The TnCCLR and TnDPX bits are not used in this Mode.

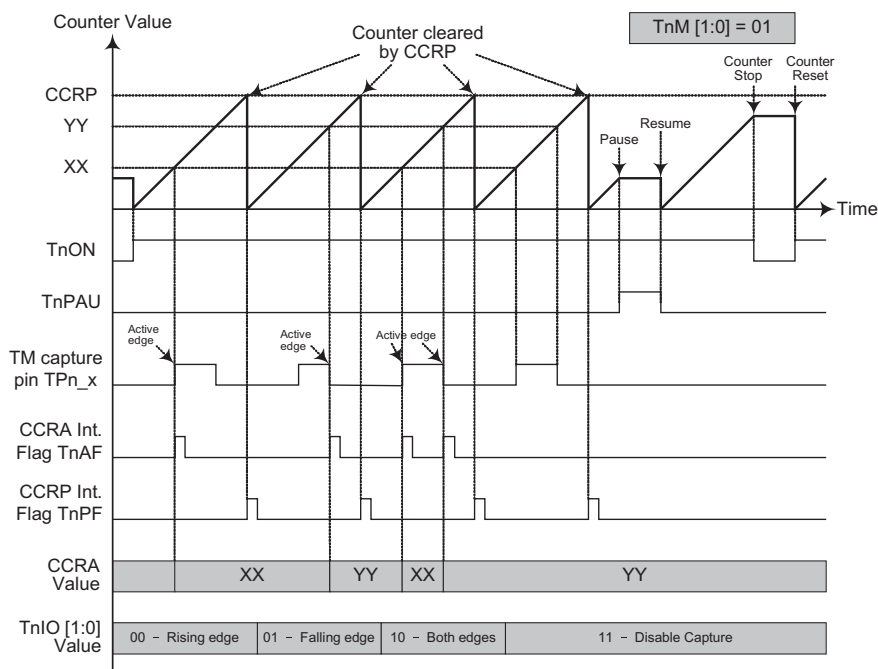

Capture Input Mode

- Note:
- 1.. TnM [1:0] = 01 and active edge set by the TnIO [1:0] bits
 2. A TM Capture input pin active edge transfers the counter value to CCRA
 3. TnCCLR bit not used
 4. No output function -- TnOC and TnPOL bits are not used
 5. CCRP determines the counter value and the counter has a maximum count value when CCRP is equal to zero.

Enhanced Type TM – ETM

The Enhanced Type TM contains five operating modes, which are Compare Match Output, Timer/Event Counter, Capture Input, Single Pulse Output and PWM Output modes. The Enhanced TM can also be controlled with an external input pin and can drive three or four external output pins.

CTM	Name	TM No.	TM Input Pin	TM Output Pin
HT66F13/HT66F14	—	—	—	—
HT66F15	10-bit ETM	1	TCK1	TP1A; TP1B_0, TP1B_1, TP1B_2

Enhanced TM Operation

At its core is a 10-bit count-up/count-down counter which is driven by a user selectable internal or external clock source. There are three internal comparators with the names, Comparator A, Comparator B and Comparator P. These comparators will compare the value in the counter with the CCRA, CCRB and CCRP registers. The CCRP comparator is 3 bits wide whose value is compared with the highest 3 bits in the counter while CCRA and CCRB are 10 bits wide and therefore compared with all counter bits.

The only way of changing the value of the 10-bit counter using the application program, is to clear the counter by changing the TnON bit from low to high. The counter will also be cleared automatically by a counter overflow or a compare match with one of its associated comparators. When these conditions occur, a TM interrupt signal will also usually be generated. The Enhanced Type TM can operate in a number of different operational modes, can be driven by different clock sources including an input pin and can also control output pins. All operating setup conditions are selected using relevant internal registers.

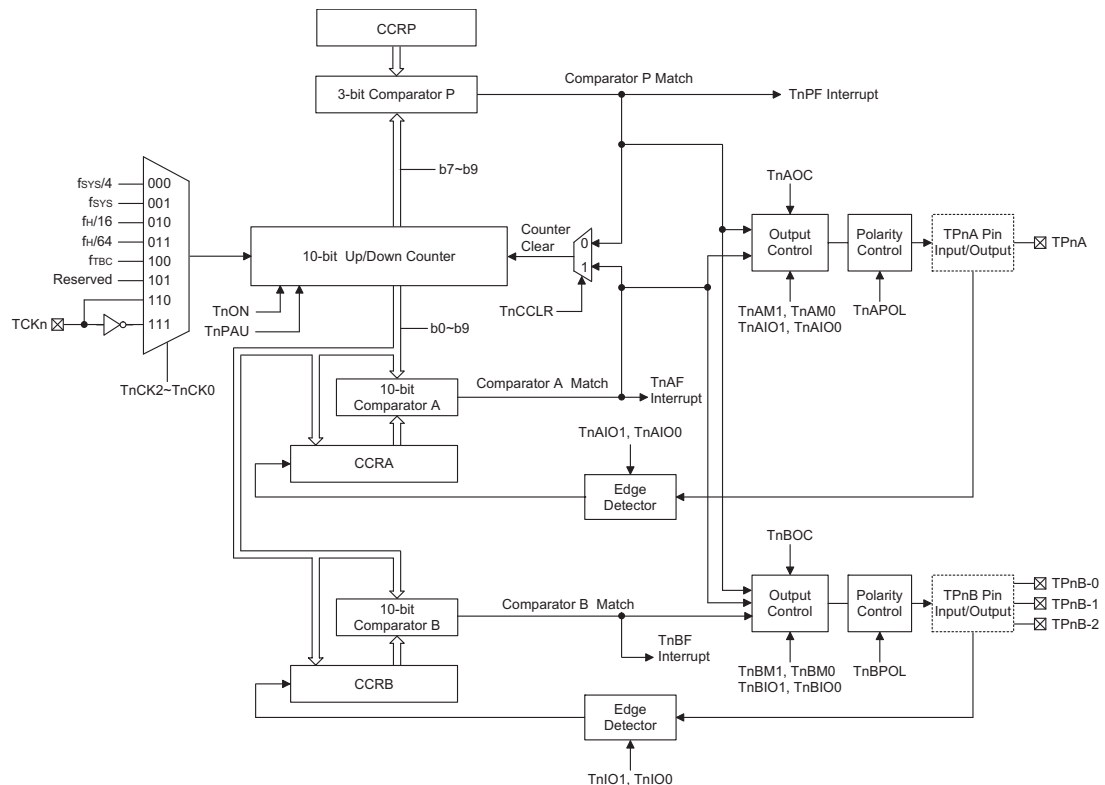

Enhanced Type TM Block Diagram

Enhanced Type TM Register Description

Overall operation of the Enhanced TM is controlled using a series of registers. A read only register pair exists to store the internal counter 10-bit value, while two read/write register pairs exist to store the internal 10-bit CCRA and CCRB value. The remaining three registers are control registers which setup the different operating and control modes as well as the three CCRP bits.

Name	Bit7	Bit6	Bit5	Bit4	Bit3	Bit2	Bit1	Bit0
TM1C0	T1PAU	T1CK2	T1CK1	T1CK0	T1ON	T1RP2	T1RP1	T1RP0
TM1C1	T1AM1	T1AM0	T1AIO1	T1AIO0	T1AOC	T1APOL	T1CDN	T1CCLR
TM1C2	T1BM1	T1BM0	T1BIO1	T1BIO0	T1BOC	T1BPOL	T1PWM1	T1PWM0
TM1DL	D7	D6	D5	D4	D3	D2	D1	D0
TM1DH	—	—	—	—	—	—	D9	D8
TM1AL	D7	D6	D5	D4	D3	D2	D1	D0
TM1AH	—	—	—	—	—	—	D9	D8
TM1BL	D7	D6	D5	D4	D3	D2	D1	D0
TM1BH	—	—	—	—	—	—	D9	D8

10-bit Enhanced TM Register List

TM1C0 Register

Bit	7	6	5	4	3	2	1	0
Name	T1PAU	T1CK2	T1CK1	T1CK0	T1ON	T1RP2	T1RP1	T1RP0
R/W	R/W	R/W	R/W	R/W	R/W	R/W	R/W	R/W
POR	0	0	0	0	0	0	0	0

Bit 7 **T1PAU**: TM1 Counter Pause Control

0: run
 1: pause

The counter can be paused by setting this bit high. Clearing the bit to zero restores normal counter operation. When in a Pause condition the TM will remain powered up and continue to consume power. The counter will retain its residual value when this bit changes from low to high and resume counting from this value when the bit changes to a low value again.

Bit 6~4 **T1CK2~T1CK0**: Select TM1 Counter clock

000: $f_{SYS}/4$
 001: f_{SYS}
 010: $f_H/16$
 011: $f_H/64$
 100: f_{TBC}
 101: Undefined
 110: TCK1 rising edge clock
 111: TCK1 falling edge clock

These three bits are used to select the clock source for the TM. Selecting the Reserved clock input will effectively disable the internal counter. The external pin clock source can be chosen to be active on the rising or falling edge. The clock source f_{SYS} is the system clock, while f_H and f_{TBC} are other internal clocks, the details of which can be found in the oscillator section.

Bit 3 **T1ON**: TM1 Counter On/Off Control
 0: Off
 1: On

This bit controls the overall on/off function of the TM. Setting the bit high enables the counter to run, clearing the bit disables the TM. Clearing this bit to zero will stop the counter from counting and turn off the TM which will reduce its power consumption. When the bit changes state from low to high the internal counter value will be reset to zero, however when the bit changes from high to low, the internal counter will retain its residual value until the bit returns high again.

If the TM is in the Compare Match Output Mode then the TM output pin will be reset to its initial condition, as specified by the T1OC bit, when the T1ON bit changes from low to high.

Bit 2~0 **T1RP2~T1RP0**: TM1 CCRP 3-bit register, compared with the TM1 Counter bit 9~bit 7
 Comparator P Match Period
 000: 1024 TM1 clocks
 001: 128 TM1 clocks
 010: 256 TM1 clocks
 011: 384 TM1 clocks
 100: 512 TM1 clocks
 101: 640 TM1 clocks
 110: 768 TM1 clocks
 111: 896 TM1 clocks

These three bits are used to setup the value on the internal CCRP 3-bit register, which are then compared with the internal counter's highest three bits. The result of this comparison can be selected to clear the internal counter if the T1CCLR bit is set to zero. Setting the T1CCLR bit to zero ensures that a compare match with the CCRP values will reset the internal counter. As the CCRP bits are only compared with the highest three counter bits, the compare values exist in 128 clock cycle multiples. Clearing all three bits to zero is in effect allowing the counter to overflow at its maximum value.

TM1C1 Register

Bit	7	6	5	4	3	2	1	0
Name	T1AM1	T1AM0	T1AIO1	T1AIO0	T1AOC	T1APOL	T1CDN	T1CCLR
R/W	R/W	R/W	R/W	R/W	R/W	R/W	R	R/W
POR	0	0	0	0	0	0	0	0

Bit 7~6 **T1AM1~T1AM0**: Select TM1 CCRA Operating Mode
 00: Compare Match Output Mode
 01: Capture Input Mode
 10: PWM Mode or Single Pulse Output Mode
 11: Timer/Counter Mode

These bits setup the required operating mode for the TM. To ensure reliable operation the TM should be switched off before any changes are made to the T1AM1 and T1AM0 bits. In the Timer/Counter Mode, the TM output pin control must be disabled.

Bit 5~4 **T1AIO1~T1AIO0**: Select TP1A output function

Compare Match Output Mode
 00: No change
 01: Output low
 10: Output high
 11: Toggle output

PWM Mode/Single Pulse Output Mode
 00: PWM output inactive state
 01: PWM output active state
 10: PWM output
 11: Single pulse output

Capture Input Mode
 00: Input capture at rising edge of TP1A
 01: Input capture at falling edge of TP1A
 10: Input capture at falling/rising edge of TP1A
 11: Input capture disabled

Timer/counter Mode
Unused

These two bits are used to determine how the TM output pin changes state when a certain condition is reached. The function that these bits select depends upon in which mode the TM is running.

In the Compare Match Output Mode, the T1AIO1 and T1AIO0 bits determine how the TM output pin changes state when a compare match occurs from the Comparator A. The TM output pin can be setup to switch high, switch low or to toggle its present state when a compare match occurs from the Comparator A. When the bits are both zero, then no change will take place on the output. The initial value of the TM output pin should be setup using the T1AOC bit in the TM1C1 register. Note that the output level requested by the T1AIO1 and T1AIO0 bits must be different from the initial value setup using the T1AOC bit otherwise no change will occur on the TM output pin when a compare match occurs. After the TM output pin changes state it can be reset to its initial level by changing the level of the T1ON bit from low to high.

In the PWM Mode, the T1AIO1 and T1AIO0 bits determine how the TM output pin changes state when a certain compare match condition occurs. The PWM output function is modified by changing these two bits. It is necessary to change the values of the T1AIO1 and T1AIO0 bits only after the TM has been switched off. Unpredictable PWM outputs will occur if the T1AIO1 and T1AIO0 bits are changed when the TM is running

Bit 3 **T1AOC:** TP1A Output control bit

Compare Match Output Mode

0: Initial low

1: Initial high

PWM Mode/ Single Pulse Output Mode

0: Active low

1: Active high

This is the output control bit for the TM output pin. Its operation depends upon whether TM is being used in the Compare Match Output Mode or in the PWM Mode/ Single Pulse Output Mode. It has no effect if the TM is in the Timer/Counter Mode. In the Compare Match Output Mode it determines the logic level of the TM output pin before a compare match occurs. In the PWM Mode it determines if the PWM signal is active high or active low.

Bit 2 **T1APOL:** TP1A Output polarity Control

0: Non-invert

1: Invert

This bit controls the polarity of the TP1A output pin. When the bit is set high the TM output pin will be inverted and not inverted when the bit is zero. It has no effect if the TM is in the Timer/Counter Mode.

Bit 1 **T1CDN:** TM1 Counter count up or down flag

0: Count up

1: Count down

Bit 0 **T1CCLR:** Select TM1 Counter clear condition

0: TM1 Comparator P match

1: TM1 Comparator A match

This bit is used to select the method which clears the counter. Remember that the Enhanced TM contains three comparators, Comparator A, Comparator B and Comparator P, but only Comparator A or Comparator P can be selected to clear the internal counter. With the T1CCLR bit set high, the counter will be cleared when a compare match occurs from the Comparator A. When the bit is low, the counter will be cleared when a compare match occurs from the Comparator P or with a counter overflow. A counter overflow clearing method can only be implemented if the CCRP bits are all cleared to zero. The T1CCLR bit is not used in the Single Pulse or Input Capture Mode.

TM1C2 Register

Bit	7	6	5	4	3	2	1	0
Name	T1BM1	T1BM0	T1BIO1	T1BIO0	T1BOC	T1BPOL	T1PWM1	T1PWM0
R/W	R/W	R/W	R/W	R/W	R/W	R/W	R	R/W
POR	0	0	0	0	0	0	0	0

Bit 7~6 **T1BM1~T1BM0**: Select TM1 CCRB Operating Mode

- 00: Compare Match Output Mode
- 01: Capture Input Mode
- 10: PWM Mode or Single Pulse Output Mode
- 11: Timer/Counter mode

These bits setup the required operating mode for the TM. To ensure reliable operation the TM should be switched off before any changes are made to the T1BM1 and T1BM0 bits. In the Timer/Counter Mode, the TM output pin control must be disabled.

Bit 5~4 **T1BIO1~T1BIO0**: Select TP1B_0, TP1B_1, TP1B_2 output function

Compare Match Output Mode

- 00: No change
- 01: Output low
- 10: Output high
- 11: Toggle output

PWM Mode/Single Pulse Output Mode

- 00: PWM output inactive state
- 01: PWM output active state
- 10: PWM output
- 11: Single pulse output

Capture Input Mode

- 00: Input capture at rising edge of TP1B_0, TP1B_1, TP1B_2
- 01: Input capture at falling edge of TP1B_0, TP1B_1, TP1B_2
- 10: Input capture at falling/rising edge of TP1B_0, TP1B_1, TP1B_2
- 11: Input capture disabled

Timer/counter Mode

Unused

These two bits are used to determine how the TM output pin changes state when a certain condition is reached. The function that these bits select depends upon in which mode the TM is running.

In the Compare Match Output Mode, the T1BIO1 and T1BIO0 bits determine how the TM output pin changes state when a compare match occurs from the Comparator A. The TM output pin can be setup to switch high, switch low or to toggle its present state when a compare match occurs from the Comparator A. When the bits are both zero, then no change will take place on the output. The initial value of the TM output pin should be setup using the T1BOC bit in the TM1C2 register. Note that the output level requested by the T1BIO1 and T1BIO0 bits must be different from the initial value setup using the T1BOC bit otherwise no change will occur on the TM output pin when a compare match occurs. After the TM output pin changes state it can be reset to its initial level by changing the level of the T1ON bit from low to high.

In the PWM Mode, the T1BIO1 and T1BIO0 bits determine how the TM output pin changes state when a certain compare match condition occurs. The PWM output function is modified by changing these two bits. It is necessary to change the values of the T1BIO1 and T1BIO0 bits only after the TM has been switched off. Unpredictable PWM outputs will occur if the T1BIO1 and T1BIO0 bits are changed when the TM is running

- Bit 3 **T1BOC**: TP1B_0, TP1B_1, TP1B_2 Output control bit
 Compare Match Output Mode
 0: Initial low
 1: Initial high
 Mode/ Single Pulse Output Mode
 0: Active low
 1: Active high
 This is the output control bit for the TM output pin. Its operation depends upon whether TM is being used in the Compare Match Output Mode or in the PWM Mode/ Single Pulse Output Mode. It has no effect if the TM is in the Timer/Counter Mode. In the Compare Match Output Mode it determines the logic level of the TM output pin before a compare match occurs. In the PWM Mode it determines if the PWM signal is active high or active low.
- Bit 2 **T1BPOL**: TP1B_0, TP1B_1, TP1B_2 Output polarity Control
 0: Non-invert
 1: Invert
 This bit controls the polarity of the TP1B_0, TP1B_1, TP1B_2 output pin. When the bit is set high the TM output pin will be inverted and not inverted when the bit is zero. It has no effect if the TM is in the Timer/Counter Mode.
- Bit 1~0 **T1PWM1~T1PWM0**: Select PWM Mode
 00: Edge aligned
 01: Centre aligned, compare match on count up
 10: Centre aligned, compare match on count down
 11: Centre aligned, compare match on count up or down

TM1DL Register

Bit	7	6	5	4	3	2	1	0
Name	D7	D6	D5	D4	D3	D2	D1	D0
R/W	R	R	R	R	R	R	R	R
POR	0	0	0	0	0	0	0	0

- Bit 7~0 **TM1DL**: TM1 Counter Low Byte Register bit 7~bit 0
 TM1 10-bit Counter bit 7~bit 0

TM1DH Register

Bit	7	6	5	4	3	2	1	0
Name	—	—	—	—	—	—	D9	D8
R/W	—	—	—	—	—	—	R	R
POR	—	—	—	—	—	—	0	0

- Bit 7~2 Unimplemented, read as "0"
 Bit 1~0 **TM1DH**: TM1 Counter High Byte Register bit 1~bit 0
 TM1 10-bit Counter bit 9~bit 8

TM1AL Register

Bit	7	6	5	4	3	2	1	0
Name	D7	D6	D5	D4	D3	D2	D1	D0
R/W	R/W	R/W	R/W	R/W	R/W	R/W	R/W	R/W
POR	0	0	0	0	0	0	0	0

- Bit 7~0 **TM1AL**: TM1 CCRA Low Byte Register bit 7~bit 0
 TM1 10-bit CCRA bit 7~bit 0

TM1AH Register

Bit	7	6	5	4	3	2	1	0
Name	—	—	—	—	—	—	D9	D8
R/W	—	—	—	—	—	—	R/W	R/W
POR	—	—	—	—	—	—	0	0

Bit 7~2 Unimplemented, read as "0"
 Bit 1~0 **TM1AH**: TM1 CCRA High Byte Register bit 1~bit 0
 TM1 10-bit CCRA bit 9~bit 8

TM1BL Register

Bit	7	6	5	4	3	2	1	0
Name	D7	D6	D5	D4	D3	D2	D1	D0
R/W	R/W	R/W	R/W	R/W	R/W	R/W	R/W	R/W
POR	0	0	0	0	0	0	0	0

Bit 7 ~ 0 **TM1BL**: TM1 CCRB Low Byte Register bit 7~bit 0
 TM1 10-bit CCRB bit 7~bit 0

TM1BH Register

Bit	7	6	5	4	3	2	1	0
Name	—	—	—	—	—	—	D9	D8
R/W	—	—	—	—	—	—	R/W	R/W
POR	—	—	—	—	—	—	0	0

Bit 7~2 Unimplemented, read as "0"
 Bit 1~0 **TM1BH**: TM1 CCRB High Byte Register bit 1~bit 0
 TM1 10-bit CCRB bit 9 ~ bit 8

Enhanced Type TM Operating Modes

The Enhanced Type TM can operate in one of five operating modes, Compare Match Output Mode, PWM Output Mode, Single Pulse Output Mode, Capture Input Mode or Timer/Counter Mode. The operating mode is selected using the TnAM1 and TnAM0 bits in the TMnC1, and the TnBM1 and TnBM0 bits in the TMnC2 register.

ETM Operating Mode	CCRA Compare Match Output Mode	CCRA Timer/Counter Mode	CCRA PWM Output Mode	CCRA Single Pulse Output Mode	CCRA Input Capture Mode
CCRB Compare Match Output Mode	√	—	—	—	—
CCRB Timer/Counter Mode	—	√	—	—	—
CCRB PWM Output Mode	—	—	√	—	—
CCRB Single Pulse Output Mode	—	—	—	√	—
CCRB Input Capture Mode	—	—	—	—	√

"√": permitted; "—" : not permitted

Compare Output Mode

To select this mode, bits TnAM1, TnAM0 and TnBM1, TnBM0 in the TMnC1/TMnC2 registers should be all cleared to zero. In this mode once the counter is enabled and running it can be cleared by three methods. These are a counter overflow, a compare match from Comparator A and a compare match from Comparator P. When the TnCCLR bit is low, there are two ways in which the counter can be cleared. One is when a compare match occurs from Comparator P, the other is when the CCRP bits are all zero which allows the counter to overflow. Here both the TnAF and TnPF interrupt request flags for Comparator A and Comparator P respectively, will both be generated.

If the TnCCLR bit in the TMnC1 register is high then the counter will be cleared when a compare match occurs from Comparator A. However, here only the TnAF interrupt request flag will be generated even if the value of the CCRP bits is less than that of the CCRA registers. Therefore when TnCCLR is high no TnPF interrupt request flag will be generated.

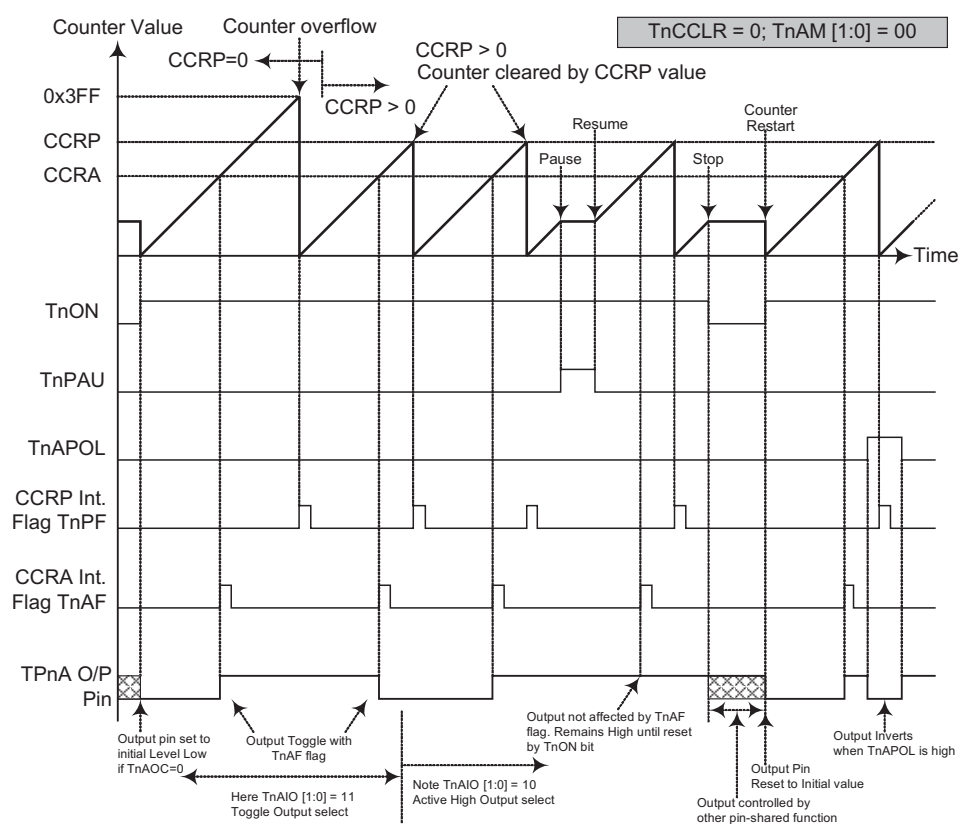

- Note:
1. With TnCCLR=0 a Comparator P match will clear the counter
 2. The TPnA output pin is controlled only by the TnAF flag
 3. The output pin is reset to its initial state by a TnON bit rising edge

As the name of the mode suggests, after a comparison is made, the TM output pin, will change state. The TM output pin condition however only changes state when a TnAF or TnBF interrupt request flag is generated after a compare match occurs from Comparator A or Comparator B. The TnPF interrupt request flag, generated from a compare match from Comparator P, will have no effect on the TM output pin. The way in which the TM output pin changes state is determined by the condition of the TnAIO1 and TnAIO0 bits in the TMnC1 register for ETM CCRA, and the TnBIO1 and TnBIO0 bits in the TMnC2 register for ETM CCRB. The TM output pin can be selected using the TnAIO1, TnAIO0 bits (for the TPnA pin) and TnBIO1, TnBIO0 bits (for the TPnB_0, TPnB_1 or TPnB_2 pins) to go high, to go low or to toggle from its present condition when a compare match occurs from Comparator A or a compare match occurs from Comparator B. The initial condition of the TM output pin, which is setup after the TnON bit changes from low to high, is setup using the TnAOC or TnBOC bit for TPnA or TPnB_0, TPnB_1, TPnB_2 output pins. Note that if the TnAIO1, TnAIO0 and TnBIO1, TnBIO0 bits are zero then no pin change will take place.

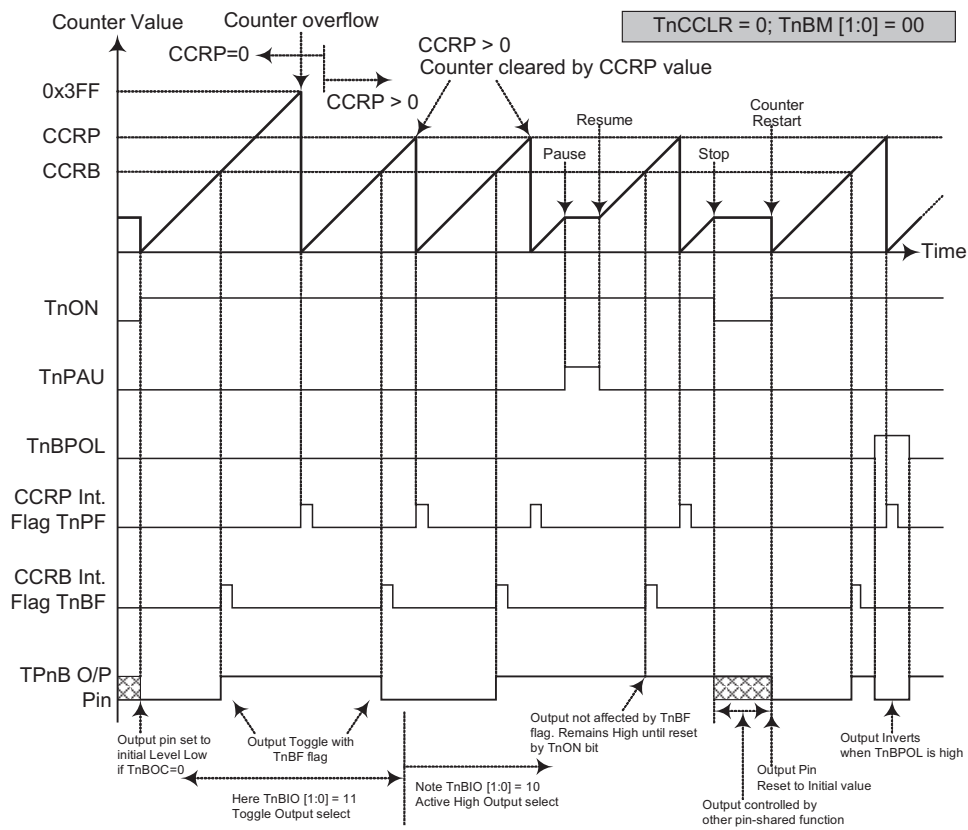

- Note:
1. With TnCCLR=0 a Comparator P match will clear the counter
 2. The TPnB output pin is controlled only by the TnBF flag
 3. The output pin is reset to its initial state by a TnON bit rising edge

As the name of the mode suggests, after a comparison is made, the TM output pin, will change state. The TM output pin condition however only changes state when an TnAF or TnBF interrupt request flag is generated after a compare match occurs from Comparator A or Comparator B. The TnPF interrupt request flag, generated from a compare match from Comparator P, will have no effect on the TM output pin. The way in which the TM output pin changes state is determined by the condition of the TnAIO1 and TnAIO0 bits in the TMnC1 register for ETM CCRA, and the TnBIO1 and TnBIO0 bits in the TMnC2 register for ETM CCRB. The TM output pin can be selected using the TnAIO1, TnAIO0 bits (for the TPnA pin) and TnBIO1, TnBIO0 bits (for the TPnB_0, TPnB_1 or TPnB_2 pins) to go high, to go low or to toggle from its present condition when a compare match occurs from Comparator A or a compare match occurs from Comparator B. The initial condition of the TM output pin, which is setup after the TnON bit changes from low to high, is setup using the TnAOC or TnBOC bit for TPnA or TPnB_0, TPnB_1, TPnB_2 output pins. Note that if the TnAIO1, TnAIO0 and TnBIO1, TnBIO0 bits are zero then no pin change will take place.

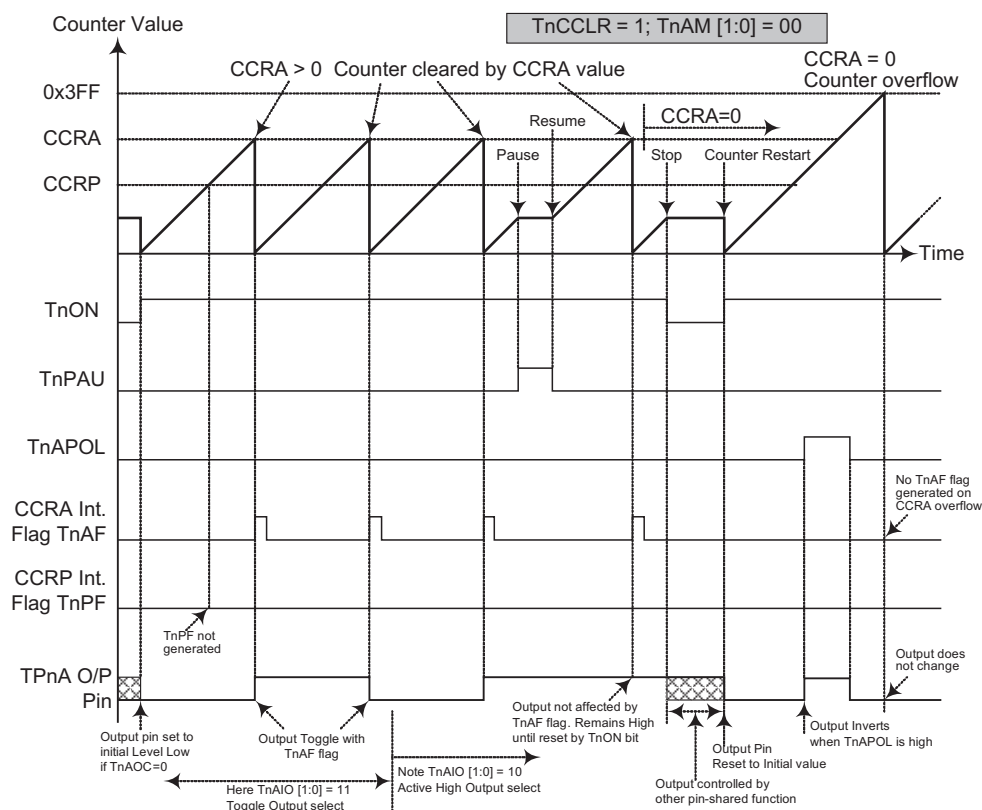

- Note:
1. With TnCCLR=1 a Comparator A match will clear the counter
 2. The TPnA output pin is controlled only by the TnAF flag
 3. The TPnA output pin is reset to its initial state by a TnON bit rising edge
 4. The TnPF flag is not generated when TnCCLR=1

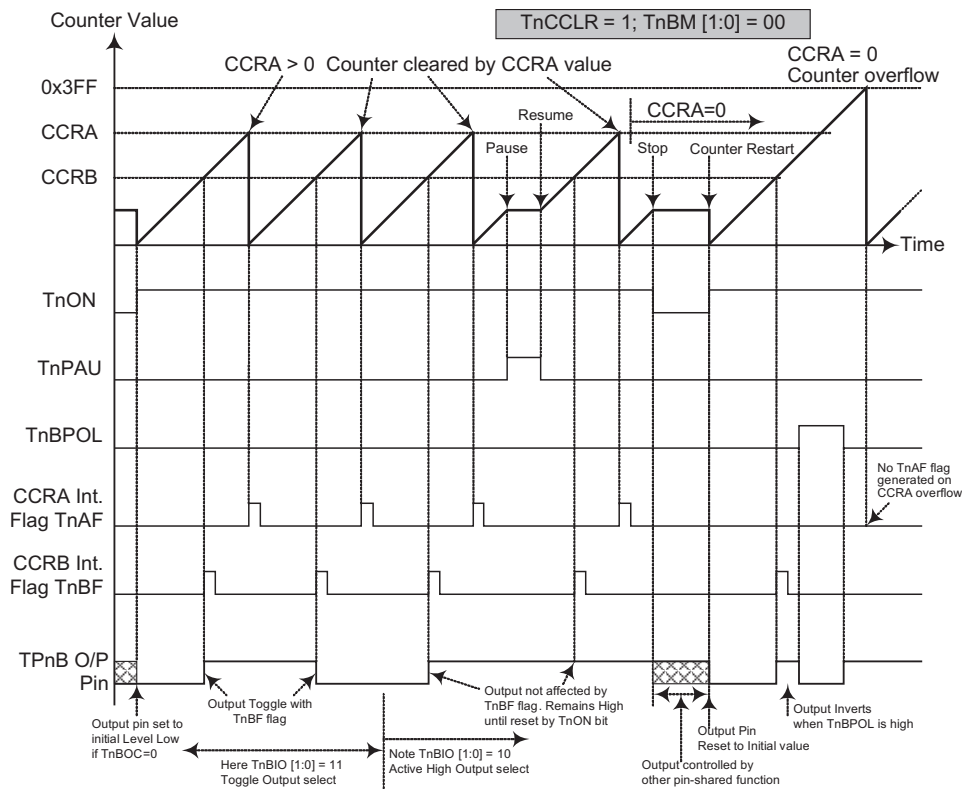

- Note:
1. With TnCCLR=1 a Comparator A match will clear the counter
 2. The TPnB output pin is controlled only by the TnBF flag
 3. The TPnB output pin is reset to its initial state by a TnON bit rising edge
 4. The TnPF flag is not generated when TnCCLR=1

Timer/Counter Mode

To select this mode, bits TnAM1, TnAM0 and TnBM1, TnBM0 in the TMnC1 and TMnC2 register should all be set high. The Timer/Counter Mode operates in an identical way to the Compare Match Output Mode generating the same interrupt flags. The exception is that in the Timer/Counter Mode the TM output pin is not used. Therefore the above description and Timing Diagrams for the Compare Match Output Mode can be used to understand its function. As the TM output pin is not used in this mode, the pin can be used as a normal I/O pin or other pin-shared function.

PWM Output Mode

To select this mode, the required bit pairs, TnAM1, TnAM0 and TnBM1, TnBM0 should be set to 10 respectively and also the TnAIO1, TnAIO0 and TnBIO1, TnBIO0 bits should be set to 10 respectively. The PWM function within the TM is useful for applications which require functions such as motor control, heating control, illumination control etc. By providing a signal of fixed frequency but of varying duty cycle on the TM output pin, a square wave AC waveform can be generated with varying equivalent DC RMS values.

As both the period and duty cycle of the PWM waveform can be controlled, the choice of generated waveform is extremely flexible. In the PWM mode, the TnCCLR bit is used to determine in which way the PWM period is controlled. With the TnCCLR bit set high, the PWM period can be finely controlled using the CCRA registers. In this case the CCRB registers are used to set the PWM duty value (for TPnB output pins). The CCRP bits are not used and TPnA output pin is not used. The PWM output can

only be generated on the TPnB output pins. With the TnCCLR bit cleared to zero, the PWM period is set using one of the eight values of the three CCRP bits, in multiples of 128. Now both CCRA and CCRB registers can be used to setup different duty cycle values to provide dual PWM outputs on their relative TPnA and TPnB pins.

The TnPWM1 and TnPWM0 bits determine the PWM alignment type, which can be either edge or centre type. In edge alignment, the leading edge of the PWM signals will all be generated concurrently when the counter is reset to zero. With all power currents switching on at the same time, this may give rise to problems in higher power applications. In centre alignment the centre of the PWM active signals will occur sequentially, thus reducing the level of simultaneous power switching currents.

Interrupt flags, one for each of the CCRA, CCRB and CCRP, will be generated when a compare match occurs from either the Comparator A, Comparator B or Comparator P. The TnAOC and TnBOC bits in the TMnC1 and TMnC2 register are used to select the required polarity of the PWM waveform while the two TnAIO1, TnAIO0 and TnBIO1, TnBIO0 bits pairs are used to enable the PWM output or to force the TM output pin to a fixed high or low level. The TnAPOL and TnBPOL bit are used to reverse the polarity of the PWM output waveform.

- ETM, PWM Mode, Edge-aligned Mode, TnCCLR=0

CCRP	001b	010b	011b	100b	101b	110b	111b	000b
Period	128	256	384	512	640	768	896	1024
A Duty	CCRA							
B Duty	CCRB							

If $f_{SYS} = 16\text{MHz}$, TM clock source select $f_{SYS}/4$, CCRP = 100b, CCRA = 128 and CCRB = 256, The TP1APWM output frequency = $(f_{SYS}/4) / 512 = f_{SYS}/2048 = 7.8125\text{kHz}$, duty = $128/512 = 25\%$. The TP1B_n PWM output frequency = $(f_{SYS}/4) / 512 = f_{SYS}/2048 = 7.8125\text{kHz}$, duty = $256/512 = 50\%$.

If the Duty value defined by CCRA or CCRB register is equal to or greater than the Period value, then the PWM output duty is 100%.

- ETM, PWM Mode, Edge-aligned Mode, TnCCLR=1

CCRA	1	2	3	511	512	1021	1022	1023
Period	1	2	3	511	512	1021	1022	1023
B Duty	CCRB							

- ETM, PWM Mode, Center-aligned Mode, TnCCLR=0

CCRP	001b	010b	011b	100b	101b	110b	111b	000b
Period	256	512	768	1024	1280	1536	1792	2046
A Duty	$(\text{CCRA} \times 2) - 1$							
B Duty	$(\text{CCRB} \times 2) - 1$							

- ETM, PWM Mode, Center-aligned Mode, TnCCLR=1

CCRA	1	2	3	511	512	1021	1022	1023
Period	2	4	6	1022	1024	2042	2044	2046
B Duty	$(\text{CCRB} \times 2) - 1$							

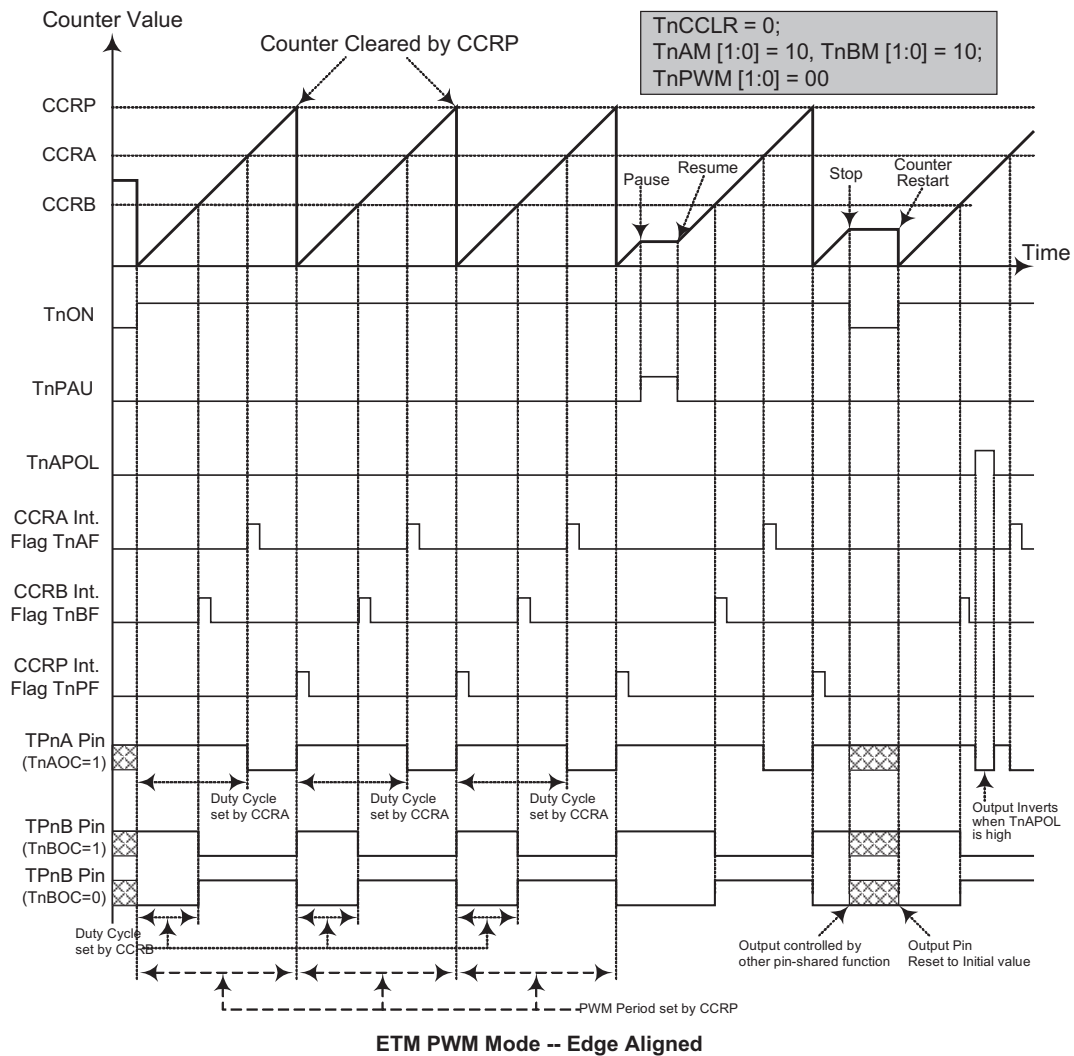

- Note:
1. Here $TnCCLR=0$ therefore CCRP clears counter and determines the PWM period
 2. The internal PWM function continues running even when $TnAIO [1:0]$ (or $TnBIO [1:0]$) = 00 or 01
 3. CCRA controls the TPnA PWM duty and CCRB controls the TPnB PWM duty

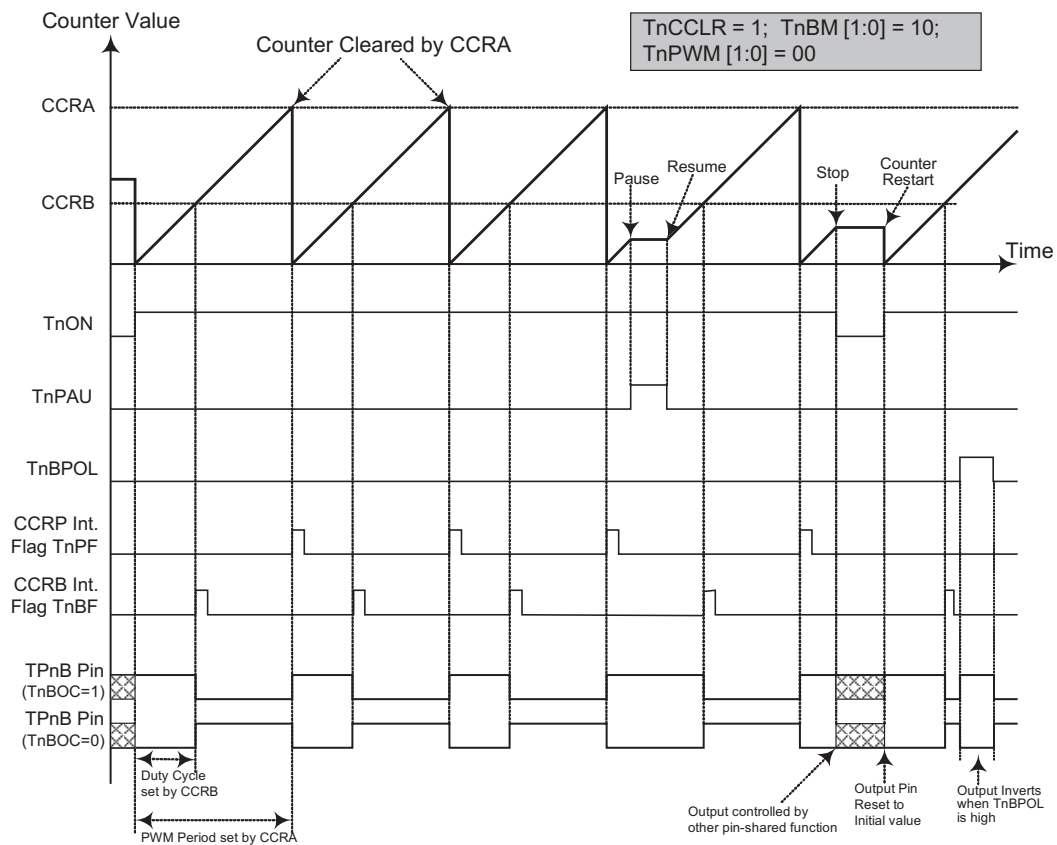

- Note:
1. Here TnCCLR=1 therefore CCRA clears the counter and determines the PWM period
 2. The internal PWM function continues running even when TnBIO [1:0] = 00 or 01
 3. The CCRA controls the TPnB PWM period and CCRB controls the TPnB PWM duty
 4. Here the TM pin control register should not enable the TPnA pin as a TM output pin.

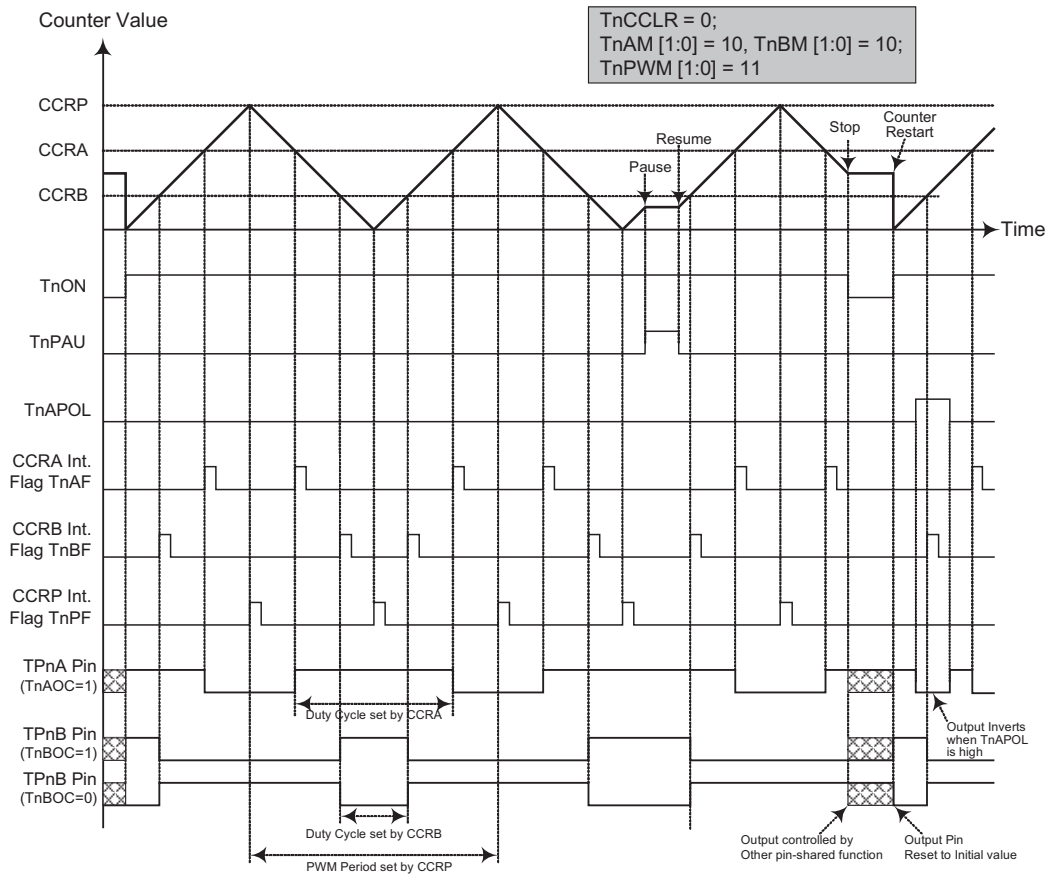

ETM PWM Mode -- Centre Aligned

- Note:
1. Here TnCCLR=0 therefore CCRP clears the counter and determines the PWM period
 2. TnPWM [1:0] =11 therefore the PWM is centre aligned
 3. The internal PWM function continues running even when TnAIO [1:0] (or TnBIO [1:0]) = 00 or 01
 4. CCRA controls the TPnA PWM duty and CCRB controls the TPnB PWM duty
 5. CCRP will generate an interrupt request when the counter decrements to its zero value

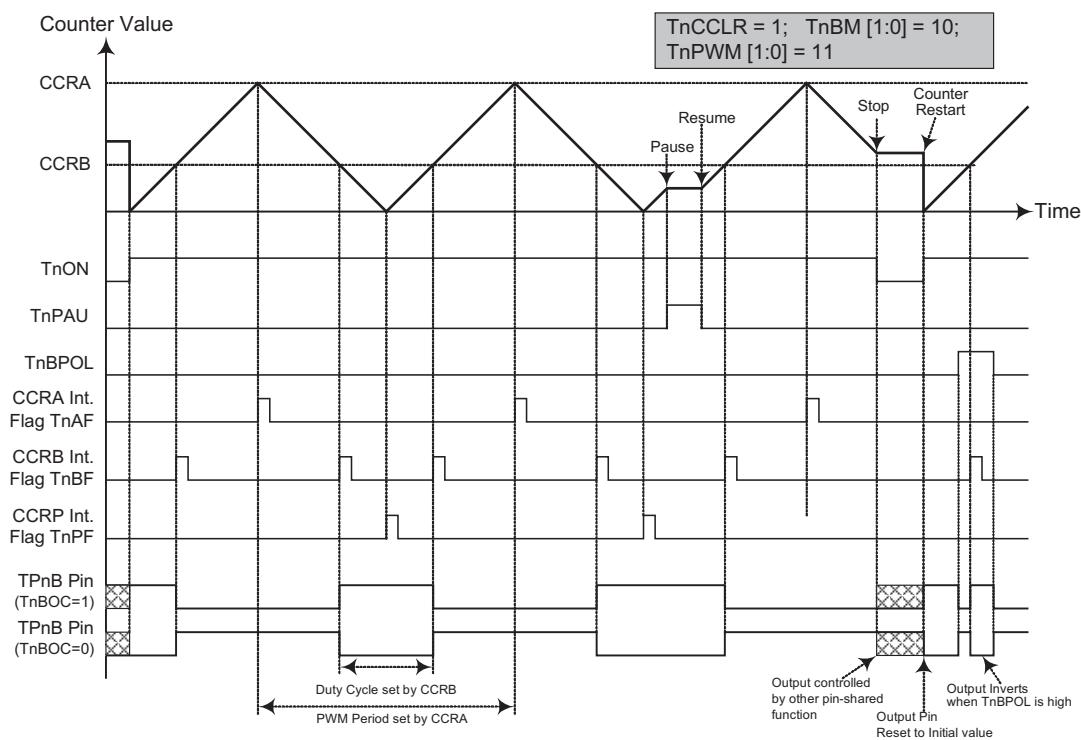

ETM PWM Mode -- Centre Aligned

- Note:
1. Here TnCCLR=1 therefore CCRA clears the counter and determines the PWM period
 2. TnPWM [1:0] =11 therefore the PWM is centre aligned
 3. The internal PWM function continues running even when TnBIO [1:0] = 00 or 01
 4. CCRA controls the TPnB PWM period and CCRB controls the TPnB PWM duty
 5. CCRP will generate an interrupt request when the counter decrements to its zero value

Single Pulse Output Mode

To select this mode, the required bit pairs, TnAM1, TnAM0 and TnBM1, TnBM0 should be set to 10 respectively and also the corresponding TnAIO1, TnAIO0 and TnBIO1, TnBIO0 bits should be set to 11 respectively. The Single Pulse Output Mode, as the name suggests, will generate a single shot pulse on the TM output pin.

The trigger for the pulse TPnA output leading edge is a low to high transition of the TnON bit, which can be implemented using the application program. The trigger for the pulse TPnB output leading edge is a compare match from Comparator B, which can be implemented using the application program. However in the Single Pulse Mode, the TnON bit can also be made to automatically change from low to high using the external TCKn pin, which will in turn initiate the Single Pulse output of TPnA. When the TnON bit transitions to a high level, the counter will start running and the pulse leading edge of TPnA will be generated. The TnON bit should remain high when the pulse is in its active state. The generated pulse trailing edge of TPnA and TPnB will be generated when the TnON bit is cleared to zero, which can be implemented using the application program or when a compare match occurs from Comparator A.

However a compare match from Comparator A will also automatically clear the TnON bit and thus generate the Single Pulse output trailing edge of TPnA and TPnB. In this way the CCRA value can be used to control the pulse width of TPnA. The CCRA-CCRB value can be used to control the pulse width of TPnB. A compare match from Comparator A and Comparator B will also generate TM interrupts. The counter can only be reset back to zero when the TnON bit changes from low to high when the counter restarts. In the Single Pulse Mode CCRP is not used. The TnCCLR bit is also not used.

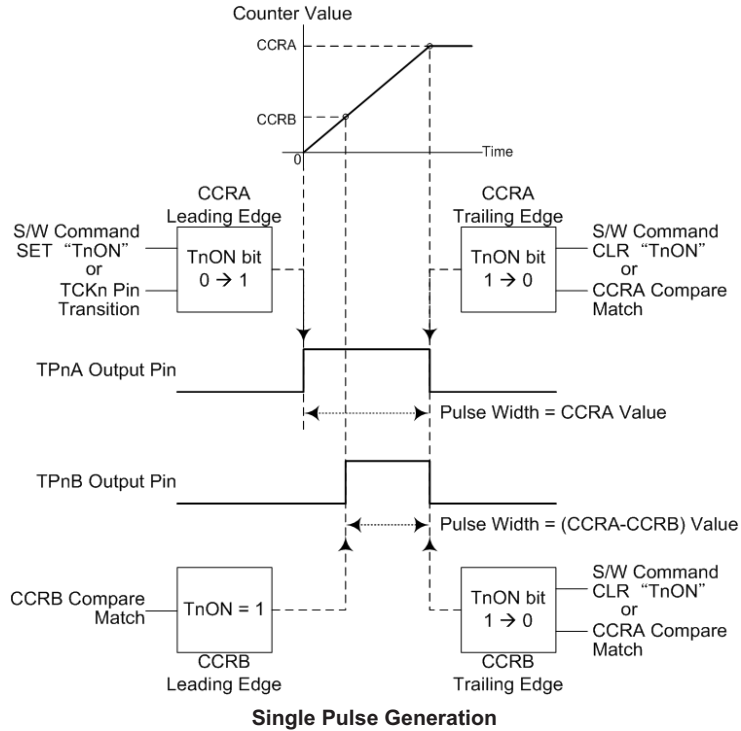

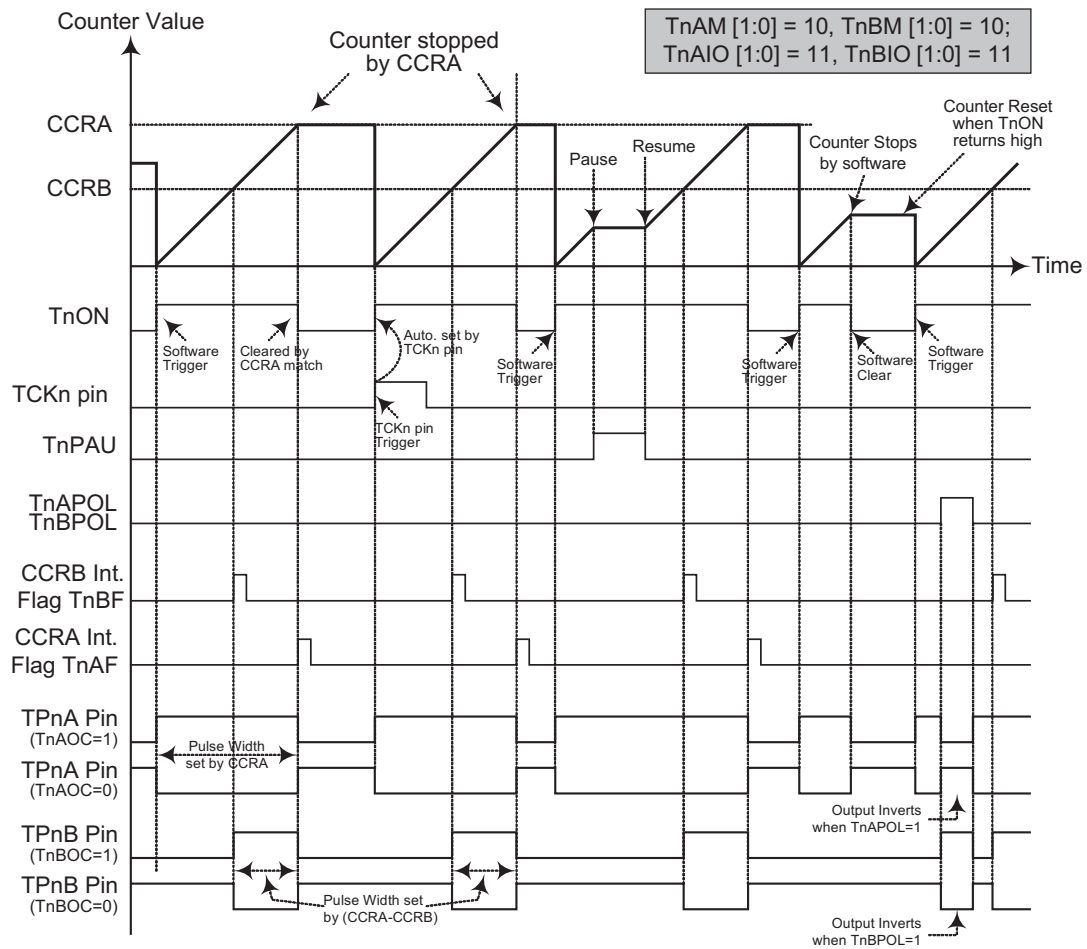

- Note:
1. Counter stopped by CCRA
 2. CCRP is not used
 3. The pulse is triggered by the TCKn pin or by setting the TnON bit high
 4. A TCKn pin active edge will automatically set the TnON bit high
 5. In the Single Pulse Mode, TnAIO [1:0] and TnBIO [1:0] must be set to "11" and can not be changed.

Capture Input Mode

To select this mode bits TnAM1, TnAM0 and TnBM1, TnBM0 in the TMnC1 and TMnC2 registers should be set to 01 respectively. This mode enables external signals to capture and store the present value of the internal counter and can therefore be used for applications such as pulse width measurements. The external signal is supplied on the TPnA and TPnB_0, TPnB_1, TPnB_2 pins, whose active edge can be either a rising edge, a falling edge or both rising and falling edges; the active edge transition type is selected using the TnAIO1, TnAIO0 and TnBIO1, TnBIO0 bits in the TMnC1 and TMnC2 registers. The counter is started when the TnON bit changes from low to high which is initiated using the application program.

When the required edge transition appears on the TPnA and TPnB_0, TPnB_1, TPnB_2 pins the present value in the counter will be latched into the CCRA and CCRB registers and a TM interrupt generated. Irrespective of what events occur on the TPnA and TPnB_0, TPnB_1, TPnB_2 pins the counter will continue to free run until the TnON bit changes from high to low. When a CCRP compare match occurs the counter will reset back to zero; in this way the CCRP value can be used to control the maximum counter value. When a CCRP compare match occurs from Comparator P, a TM interrupt will also be generated. Counting the number of overflow interrupt signals from the CCRP can be a useful method in measuring long pulse widths. The TnAIO1, TnAIO0 and TnBIO1, TnBIO0 bits can select the active trigger edge on the TPnA and TPnB_0, TPnB_1, TPnB_2 pins to be a rising edge, falling edge or both edge types. If the TnAIO1, TnAIO0 and TnBIO1, TnBIO0 bits are both set high, then no capture operation will take place irrespective of what happens on the TPnA and TPnB_0, TPnB_1, TPnB_2 pins, however it must be noted that the counter will continue to run.

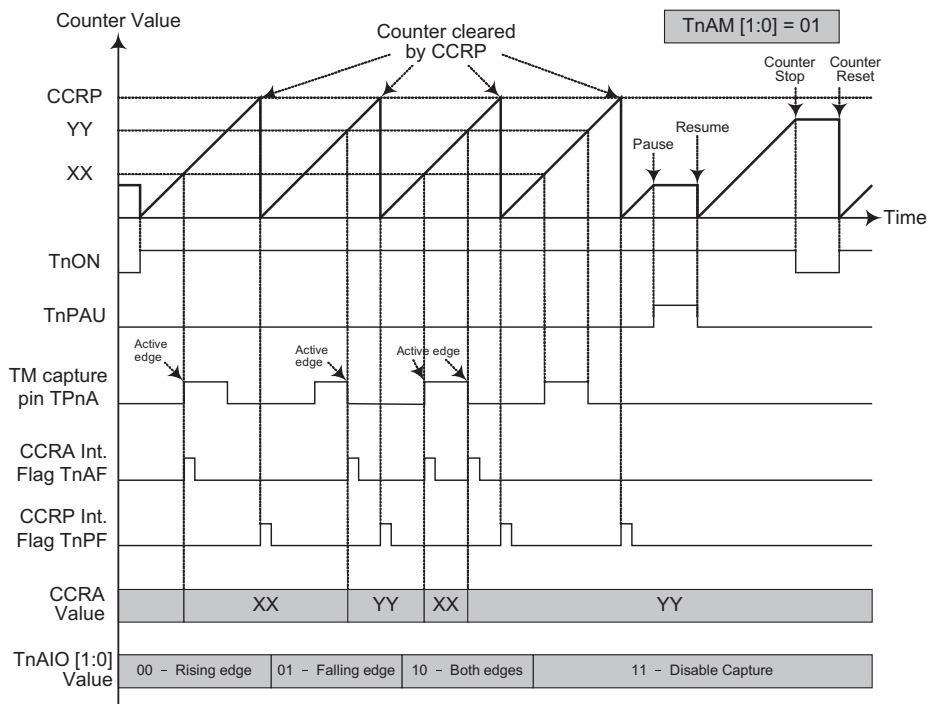

ETM CCRA Capture Input Mode

- Note:
1. TnAM [1:0] = 01 and active edge set by the TnAIO [1:0] bits
 2. The TM Capture input pin active edge transfers the counter value to CCRA
 3. TnCCLR bit not used
 4. No output function -- TnAOC and TnAPOL bits not used
 5. CCRP determines the counter value and the counter has a maximum count value when CCRP is equal to zero.

As the TPnA and TPnB_0, TPnB_1, TPnB_2 pins are pin shared with other functions, care must be taken if the TM is in the Capture Input Mode. This is because if the pin is setup as an output, then any transitions on this pin may cause an input capture operation to be executed. The TnCCLR, TnAOC, TnBOC, TnAPOL and TnBPOL bits are not used in this mode.

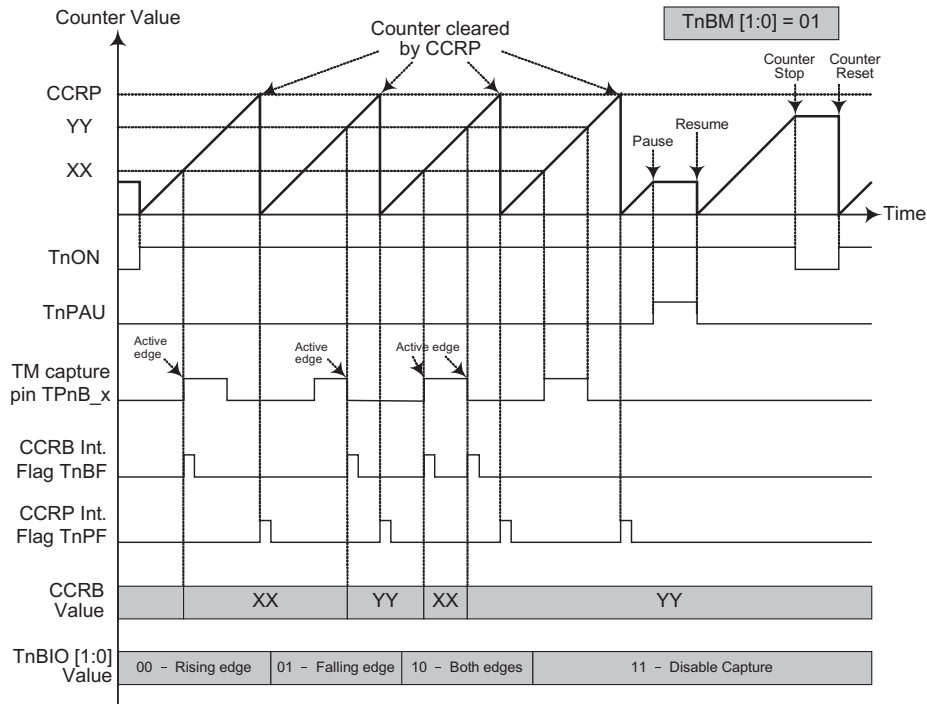

ETM CCRB Capture Input Mode

- Note:
1. TnBM [1:0] = 01 and active edge set by the TnBIO [1:0] bits
 2. The TM Capture input pin active edge transfers the counter value to CCRB
 3. TnCCLR bit not used
 4. No output function -- TnBOC and TnBPOL bits not used
 5. CCRP determines the counter value and the counter has a maximum count value when CCRP is equal to zero.

Analog to Digital Converter

The need to interface to real world analog signals is a common requirement for many electronic systems. However, to properly process these signals by a microcontroller, they must first be converted into digital signals by A/D converters. By integrating the A/D conversion electronic circuitry into the microcontroller, the need for external components is reduced significantly with the corresponding follow-on benefits of lower costs and reduced component space requirements.

A/D Overview

The devices contain a multi-channel analog to digital converter which can directly interface to external analog signals, such as that from sensors or other control signals and convert these signals directly into a 12-bit digital value.

The accompanying block diagram shows the overall internal structure of the A/D converter, together with its associated registers.

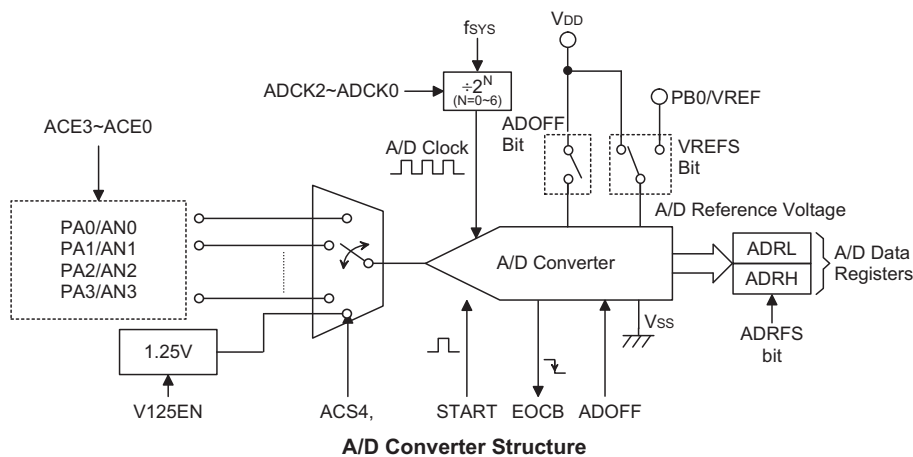

A/D Converter Register Description

Overall operation of the A/D converter is controlled using six registers. A read only register pair exists to store the ADC data 12-bit value. The remaining three or four registers are control registers which setup the operating and control function of the A/D converter.

Register Name	Bit							
	7	6	5	4	3	2	1	0
ADRL(ADRFS=0)	D3	D2	D1	D0	—	—	—	—
ADRL(ADRFS=1)	D7	D6	D5	D4	D3	D2	D1	D0
ADRH(ADRFS=0)	D11	D10	D9	D8	D7	D6	D5	D4
ADRH(ADRFS=1)	—	—	—	—	D11	D10	D9	D8
ADCR0	START	EOCB	ADOFF	ADRFS	—	—	ACS1	ACS0
ADCR1	ACS4	V125EN	—	VREFS	—	ADCK2	ADCK1	ADCK0
ACER	—	—	—	—	ACE3	ACE2	ACE1	ACE0

A/D Converter Register List

A/D Converter Data Registers – ADRL, ADRH

As the devices contain an internal 12-bit A/D converter, they require two data registers to store the converted value. These are a high byte register, known as ADRH, and a low byte register, known as ADRL. After the conversion process takes place, these registers can be directly read by the microcontroller to obtain the digitised conversion value. As only 12 bits of the 16-bit register space is utilised, the format in which the data is stored is controlled by the ADRFS bit in the ADCR0 register as shown in the accompanying table. D0~D11 are the A/D conversion result data bits. Any unused bits will be read as zero.

ADRFS	ADRH								ADRL							
	7	6	5	4	3	2	1	0	7	6	5	4	3	2	1	0
0	D11	D10	D9	D8	D7	D6	D5	D4	D3	D2	D1	D0	0	0	0	0
1	0	0	0	0	D11	D10	D9	D8	D7	D6	D5	D4	D3	D2	D1	D0

A/D Data Registers

A/D Converter Control Registers – ADCR0, ADCR1, ACER

To control the function and operation of the A/D converter, three control registers known as ADCR0, ADCR1 and ACER are provided. These 8-bit registers define functions such as the selection of which analog channel is connected to the internal A/D converter, the digitised data format, the A/D clock source as well as controlling the start function and monitoring the A/D converter end of conversion status. The ACS1~ACS0 bits in the ADCR0 register and ACS4 bit in the ADCR1 register define the ADC input channel number. As the device contains only one actual analog to digital converter hardware circuit, each of the individual 4 analog inputs must be routed to the converter. It is the function of the ACS4 and ACS1~ACS0 bits to determine which analog channel input pins or internal 1.25V is actually connected to the internal A/D converter.

The ACER control register contains the ACER3~ACER0 bits which determine which pins on PA0~PA3 are used as analog inputs for the A/D converter input and which pins are not to be used as the A/D converter input. Setting the corresponding bit high will select the A/D input function, clearing the bit to zero will select either the I/O or other pin-shared function. When the pin is selected to be an A/D input, its original function whether it is an I/O or other pin-shared function will be removed. In addition, any internal pull-high resistors connected to these pins will be automatically removed if the pin is selected to be an A/D input.

ADCR0 Register

Bit	7	6	5	4	3	2	1	0
Name	START	EOCB	ADOFF	ADRF5	—	—	ACS1	ACS0
R/W	R/W	R	R/W	R/W	—	—	R/W	R/W
POR	0	1	1	0	—	—	0	0

- Bit 7** **START:** Start the A/D conversion
 0→1→0 : start
 0→1 : reset the A/D converter and set EOCB to "1"
 This bit is used to initiate an A/D conversion process. The bit is normally low but if set high and then cleared low again, the A/D converter will initiate a conversion process. When the bit is set high the A/D converter will be reset.
- Bit 6** **EOCB:** End of A/D conversion flag
 0: A/D conversion ended
 1: A/D conversion in progress
 This read only flag is used to indicate when an A/D conversion process has completed. When the conversion process is running the bit will be high.
- Bit 5** **ADOFF :** ADC module power on/off control bit
 0: ADC module power on
 1: ADC module power off
 This bit controls the power to the A/D internal function. This bit should be cleared to zero to enable the A/D converter. If the bit is set high then the A/D converter will be switched off reducing the device power consumption. As the A/D converter will consume a limited amount of power, even when not executing a conversion, this may be an important consideration in power sensitive battery powered applications.
 Note: 1. it is recommended to set ADOFF=1 before entering IDLE/SLEEP Mode for saving power.
 2. ADOFF=1 will power down the ADC module.
- Bit 4** **ADRF5:** ADC Data Format Control
 0: ADC Data MSB is ADRH bit 7, LSB is ADRL bit 4
 1: ADC Data MSB is ADRH bit 3, LSB is ADRL bit 0
 This bit controls the format of the 12-bit converted A/D value in the two A/D data registers. Details are provided in the A/D data register section.
- Bit 3~2** unimplemented, read as "0"
- Bit 1~0** **ACS1, ACS0:** Select A/D channel (when ACS4 is "0")
 00: AN0
 01: AN1
 10: AN2
 11: AN3

ADCR1 Register

Bit	7	6	5	4	3	2	1	0
Name	ACS4	V125EN	—	VREFS	—	ADCK2	ADCK1	ADCK0
R/W	R/W	R/W	—	R/W	—	R/W	R/W	R/W
POR	0	0	—	0	—	0	0	0

- Bit 7** **ACS4:** Selecte Internal 1.25V as ADC input Control
 0: Disable
 1: Enable
 This bit enables 1.25V to be connected to the A/D converter. The V125EN bit must first have been set to enable the bandgap circuit 1.25V voltage to be used by the A/D converter. When the ACS4 bit is set high, the bandgap 1.25V voltage will be routed to the A/D converter and the other A/D input channels disconnected.
- Bit 6** **V125EN:** Internal 1.25V Control
 0: Disable
 1: Enable
 This bit controls the internal Bandgap circuit on/off function to the A/D converter. When the bit is set high the bandgap voltage 1.25V can be used by the A/D converter. If 1.25V is not used by the A/D converter and the LVR/LVD function is disabled then the bandgap reference circuit will be automatically switched off to conserve power. When 1.25V is switched on for use by the A/D converter, a time t_{bc} should be allowed for the bandgap circuit to stabilise before implementing an A/D conversion.
- Bit 5** unimplemented, read as "0"
- Bit 4** **VREFS:** Selecte ADC reference voltage
 0: Internal ADC power
 1: VREF pin
 This bit is used to select the reference voltage for the A/D converter. If the bit is high, then the A/D converter reference voltage is supplied on the external VREF pin. If the pin is low, then the internal reference is used which is taken from the power supply pin VDD.
- Bit 3** unimplemented, read as "0"
- Bit 2~0** **ADCK2, ADCK1, ADCK0:** Select ADC clock source
 000: f_{SYS}
 001: $f_{SYS}/2$
 010: $f_{SYS}/4$
 011: $f_{SYS}/8$
 100: $f_{SYS}/16$
 101: $f_{SYS}/32$
 110: $f_{SYS}/64$
 111: Undefined
 These three bits are used to select the clock source for the A/D converter.

ACERL Register

Bit	7	6	5	4	3	2	1	0
Name	—	—	—	—	ACE3	ACE2	ACE1	ACE0
R/W	—	—	—	—	R/W	R/W	R/W	R/W
POR	—	—	—	—	1	1	1	1

- Bit 7~4 unimplemented, read as "0"
- Bit 3 **ACE3**: Define PA3 is A/D input or not
0: Not A/D input
1: A/D input, AN3
- Bit 2 **ACE2**: Define PA2 is A/D input or not
0: Not A/D input
1: A/D input, AN2
- Bit 1 **ACE1**: Define PA1 is A/D input or not
0: Not A/D input
1: A/D input, AN1
- Bit 0 **ACE0**: Define PA0 is A/D input or not
0: Not A/D input
1: A/D input, AN0

A/D Operation

The START bit in the ADCR0 register is used to start and reset the A/D converter. When the microcontroller sets this bit from low to high and then low again, an analog to digital conversion cycle will be initiated. When the START bit is brought from low to high but not low again, the EOCB bit in the ADCR0 register will be set high and the analog to digital converter will be reset. It is the START bit that is used to control the overall start operation of the internal analog to digital converter.

The EOCB bit in the ADCR0 register is used to indicate when the analog to digital conversion process is complete. This bit will be automatically set to 0 by the microcontroller after a conversion cycle has ended. In addition, the corresponding A/D interrupt request flag will be set in the interrupt control register, and if the interrupts are enabled, an appropriate internal interrupt signal will be generated. This A/D internal interrupt signal will direct the program flow to the associated A/D internal interrupt address for processing. If the A/D internal interrupt is disabled, the microcontroller can be used to poll the EOCB bit in the ADCR0 register to check whether it has been cleared as an alternative method of detecting the end of an A/D conversion cycle.

The clock source for the A/D converter, which originates from the system clock f_{SYS} , can be chosen to be either f_{SYS} or a subdivided version of f_{SYS} . The division ratio value is determined by the ADCK2~ADCK0 bits in the ADCR1 register.

Although the A/D clock source is determined by the system clock f_{SYS} , and by bits ADCK2~ADCK0, there are some limitations on the maximum A/D clock source speed that can be selected. As the minimum value of permissible A/D clock period, t_{ADCK} , is 0.5 μ s, care must be taken for system clock frequencies equal to or greater than 4MHz. For example, if the system clock operates at a frequency of 4MHz, the ADCK2~ADCK0 bits should not be set to 000B. Doing so will give A/D clock periods that are less than the minimum A/D clock period which may result in inaccurate A/D conversion values. Refer to the following table for examples, where values marked with an asterisk * show where, depending upon the device, special care must be taken, as the values may be less than the specified minimum A/D Clock Period.

f _{sys}	A/D Clock Period (t _{ADCK})							
	ADCK2, ADCK1, ADCK0 = 000 (f _{sys})	ADCK2, ADCK1, ADCK0 = 001 (f _{sys} /2)	ADCK2, ADCK1, ADCK0 = 010 (f _{sys} /4)	ADCK2, ADCK1, ADCK0 = 011 (f _{sys} /8)	ADCK2, ADCK1, ADCK0 = 100 (f _{sys} /16)	ADCK2, ADCK1, ADCK0 = 101 (f _{sys} /32)	ADCK2, ADCK1, ADCK0 = 110 (f _{sys} /64)	ADCK2, ADCK1, ADCK0 = 111
1MHz	1μs	2μs	4μs	8μs	16μs	32μs	64μs	Undefined
2MHz	500ns	1μs	2μs	4μs	8μs	16μs	32μs	Undefined
4MHz	250ns*	500ns	1μs	2μs	4μs	8μs	16μs	Undefined
8MHz	125ns*	250ns*	500ns	1μs	2μs	4μs	8μs	Undefined
12MHz	83ns*	167ns*	333ns*	667ns	1.33μs	2.67μs	5.33μs	Undefined

A/D Clock Period Examples

Controlling the power on/off function of the A/D converter circuitry is implemented using the ADOFF bit in the ADCR0 register. This bit must be zero to power on the A/D converter. When the ADOFF bit is cleared to zero to power on the A/D converter internal circuitry a certain delay, as indicated in the timing diagram, must be allowed before an A/D conversion is initiated. Even if no pins are selected for use as A/D inputs by clearing the ACE3~ACE0 bits in the ACER register, if the ADOFF bit is zero then some power will still be consumed. In power conscious applications it is therefore recommended that the ADOFF is set high to reduce power consumption when the A/D converter function is not being used.

The reference voltage supply to the A/D Converter can be supplied from either the positive power supply pin, VDD, or from an external reference sources supplied on pin VREF. The desired selection is made using the VREFS bit. As the VREF pin is pin-shared with other functions, when the VREFS bit is set high, the VREF pin function will be selected and the other pin functions will be disabled automatically.

A/D Input Pins

All of the A/D analog input pins are pin-shared with the I/O pins on PA3~PA0 as well as other functions. The ACE3~ACE0 bits in the ACER register determines whether the input pins are setup as A/D converter analog inputs or whether they have other functions. If the ACE3~ACE0 bits for its corresponding pin is set high then the pin will be setup to be an A/D converter input and the original pin functions disabled. In this way, pins can be changed under program control to change their function between A/D inputs and other functions. All pull-high resistors, which are setup through register programming, will be automatically disconnected if the pins are setup as A/D inputs. Note that it is not necessary to first setup the A/D pin as an input in the PAC port control register to enable the A/D input as when the ACE3~ACE0 bits enable an A/D input, the status of the port control register will be overridden.

The A/D converter has its own reference voltage pin VREF however the reference voltage can also be supplied from the power supply pin, a choice which is made through the VREFS bit in the ADCR1 register. The analog input values must not be allowed to exceed the value of VREF.

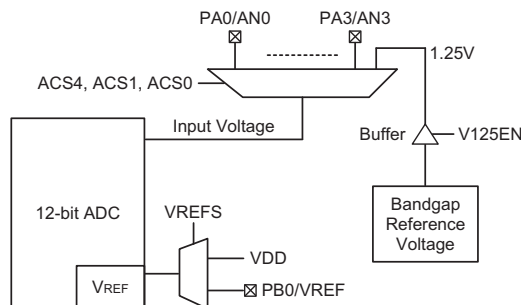

A/D Input Structure

Summary of A/D Conversion Steps

The following summarises the individual steps that should be executed in order to implement an A/D conversion process.

- Step 1
Select the required A/D conversion clock by correctly programming bits ADCK2~ADCK0 in the ADCR1 register.
- Step 2
Enable the A/D by clearing the ADOFF bit in the ADCR0 register to zero.
- Step 3
Select which channel is to be connected to the internal A/D converter by correctly programming the ACS4 and ACS1~ACS0 bits which are also contained in the ADCR1 and ADCR0 registers.
- Step 4
Select which pins are to be used as A/D inputs and configure them by correctly programming the ACE11~ACE0 bits in the ACERH and ACERL registers.
- Step 5
If the interrupts are to be used, the interrupt control registers must be correctly configured to ensure the A/D converter interrupt function is active. The master interrupt control bit, EMI, and the A/D converter interrupt bit, ADE, must both be set to high to do this.
- Step 6
The analog to digital conversion process can now be initialised by setting the START bit in the ADCR0 register from low to high and then to low again. Note that this bit should have been originally cleared to 0.
- Step 7
To check when the analog to digital conversion process is complete, the EOCB bit in the ADCR0 register can be polled. The conversion process is complete when this bit goes low. When this occurs, the A/D data registers ADRL and ADRH can be read to obtain the conversion value. As an alternative method if the interrupts are enabled and the stack is not full, the program can wait for an A/D interrupt to occur.
Note: When checking for the end of the conversion process, if the method of polling the EOCB bit in the ADCR register is used, the interrupt enable step above can be omitted.

The accompanying diagram shows graphically the various stages involved in an analog to digital conversion process and its associated timing. After an A/D conversion process has been initiated by the application program, the microcontroller internal hardware will begin to carry out the conversion, during which time the program can continue with other functions. The time taken for the A/D conversion is $16 t_{ADCK}$ where t_{ADCK} is equal to the A/D clock period.

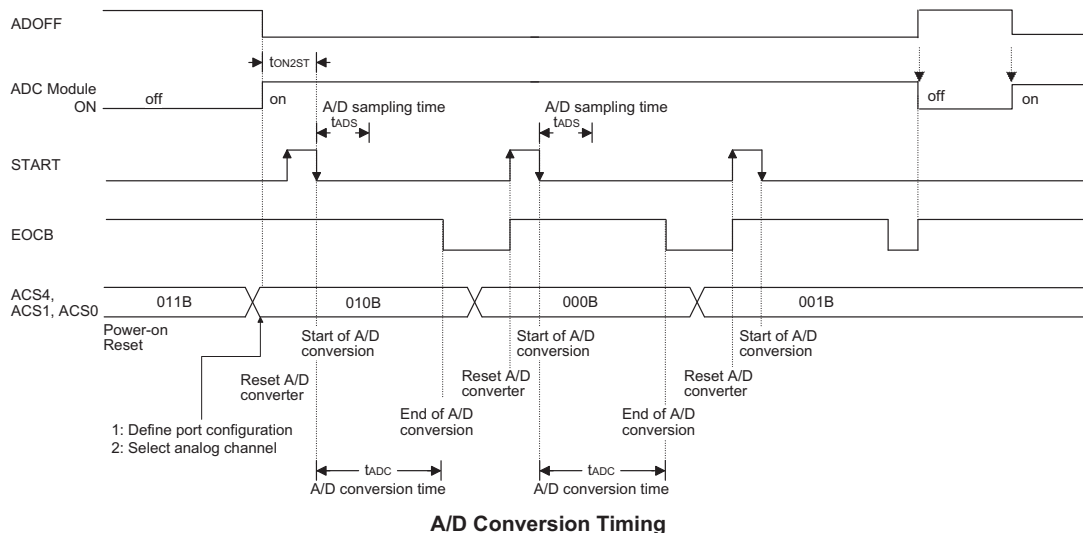

Programming Considerations

During microcontroller operates where the A/D converter is not being used, the A/D internal circuitry can be switched off to reduce power consumption, by setting bit ADOFF high in the ADCR0 register. When this happens, the internal A/D converter circuits will not consume power irrespective of what analog voltage is applied to their input lines. If the A/D converter input lines are used as normal I/Os, then care must be taken as if the input voltage is not at a valid logic level, then this may lead to some increase in power consumption.

A/D Transfer Function

As the devices contain a 12-bit A/D converter, its full-scale converted digitised value is equal to FFFH. Since the full-scale analog input value is equal to the V_{DD} or V_{REF} voltage, this gives a single bit analog input value of V_{DD} or V_{REF} divided by 4096.

$$1 \text{ LSB} = (V_{DD} \text{ or } V_{REF}) \div 4096$$

The A/D Converter input voltage value can be calculated using the following equation:

$$\text{A/D input voltage} = \text{A/D output digital value} \times (V_{DD} \text{ or } V_{REF}) \div 4096$$

The diagram shows the ideal transfer function between the analog input value and the digitised output value for the A/D converter. Except for the digitised zero value, the subsequent digitised values will change at a point 0.5 LSB below where they would change without the offset, and the last full scale digitised value will change at a point 1.5 LSB below the V_{DD} or V_{REF} level.

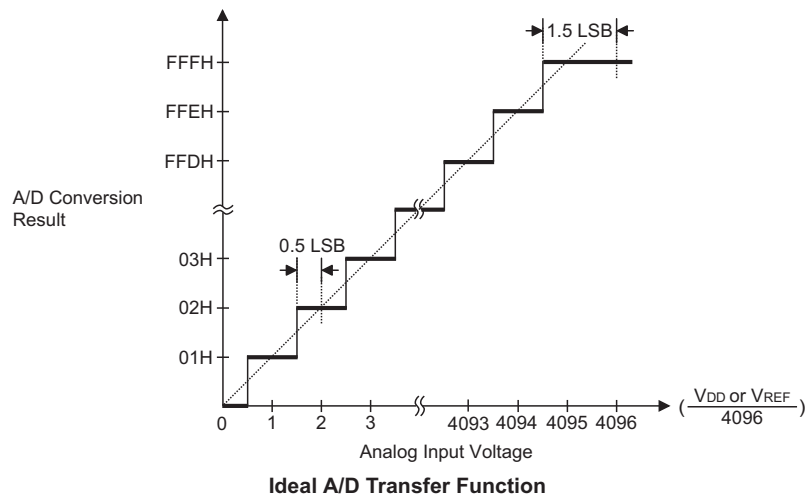

A/D Programming Example

The following two programming examples illustrate how to setup and implement an A/D conversion. In the first example, the method of polling the EOCB bit in the ADCR0 register is used to detect when the conversion cycle is complete, whereas in the second example, the A/D interrupt is used to determine when the conversion is complete.

Example 1: using an EOCB polling method to detect the end of conversion

```

clr   ADE           ; disable ADC interrupt
mov   a,03H
mov   ADCR1,a      ; select fsys/8 as A/D clock and switch off 1.25V
clr   ADOFF
mov   a,0Fh       ; setup ACER register to configure pins AN0~AN3
mov   ACER,a
mov   a,00h
mov   ADCR0,a     ; enable and connect AN0 channel to A/D converter
:
start_conversion:
clr   START       ; high pulse on start bit to initiate conversion
set   START       ; reset A/D
clr   START       ; start A/D
polling_EOC:
sz    EOCB        ; poll the ADCR0 register EOCB bit to detect end of A/D conversion
jmp   polling_EOC ; continue polling
mov   a,ADRL      ; read low byte conversion result value
mov   ADRL_buffer,a ; save result to user defined register
mov   a,ADRH      ; read high byte conversion result value
mov   ADRH_buffer,a ; save result to user defined register
:
jmp   start_conversion ; start next a/d conversion

```

Example 2: using the interrupt method to detect the end of conversion

```
clr    ADE                ; disable ADC interrupt
mov    a,03H
mov    ADCR1,a            ; select fSYS/8 as A/D clock and switch off 1.25V
clr    ADOFF
mov    a,0Fh             ; setup ACER register to configure pins AN0~AN3
mov    ACER,a
mov    a,00h
mov    ADCR0,a           ; enable and connect AN0 channel to A/D converter
Start_conversion:
clr    START             ; high pulse on START bit to initiate conversion
set    START             ; reset A/D
clr    START             ; start A/D
clr    ADF               ; clear ADC interrupt request flag
set    ADE               ; enable ADC interrupt
set    EMI               ; enable global interrupt
:
; ADC interrupt service routine
ADC_ISR:
mov    acc_stack,a       ; save ACC to user defined memory
mov    a,STATUS
mov    status_stack,a    ; save STATUS to user defined memory
:
mov    a,ADRL            ; read low byte conversion result value
mov    adr1_buffer,a     ; save result to user defined register
mov    a,ADRH            ; read high byte conversion result value
mov    adrh_buffer,a    ; save result to user defined register
:
EXIT_INT_ISR:
mov    a,status_stack
mov    STATUS,a         ; restore STATUS from user defined memory
mov    a,acc_stack      ; restore ACC from user defined memory
reti
```

Interrupts

Interrupts are an important part of any microcontroller system. When an external event or an internal function such as a Timer Module or an A/D converter requires microcontroller attention, their corresponding interrupt will enforce a temporary suspension of the main program allowing the microcontroller to direct attention to their respective needs. The device contains several external interrupt and internal interrupts functions. The external interrupts are generated by the action of the external INT0 and INT1 pins while the internal interrupts are generated by various internal functions such as the TMs, Time Base, LVD and the A/D converter.

Interrupt Registers

Overall interrupt control, which basically means the setting of request flags when certain microcontroller conditions occur and the setting of interrupt enable bits by the application program, is controlled by a series of registers, located in the Special Purpose Data Memory, as shown in the accompanying table. The number of registers depends upon the device chosen but fall into three categories. The first is the INTC0~INTC1 registers which setup the primary interrupts, the second is the MFI0~MFI1 registers which setup the Multi-function interrupts. Finally there is an INTEG register to setup the external interrupt trigger edge type.

Each register contains a number of enable bits to enable or disable individual registers as well as interrupt flags to indicate the presence of an interrupt request. The naming convention of these follows a specific pattern. First is listed an abbreviated interrupt type, then the (optional) number of that interrupt followed by either an "E" for enable/ disable bit or "F" for request flag.

Function	Enable Bit	Request Flag	Notes
Global	EMI	—	—
INTn Pin	INTnE	INTnF	n = 0 or 1
Multi-function	MFnE	MFnF	n = 0 or 1
A/D Converter	ADE	ADF	—
Time Base	TBE	TBF	—
LVD	LVE	LVF	—
TM	TnPE	TnPF	n = 0 or 1
	TnAE	TnAF	
	TnBE	TnBF	n = 1

Interrupt Register Bit Naming Conventions

Interrupt Register Contents – HT66F13

Name	Bit							
	7	6	5	4	3	2	1	0
INTEG	—	—	—	—	INT1S1	INT1S0	INT0S1	INT0S0
INTC0	—	T1PF	INT1F	INT0F	T1PE	INT1E	INT0E	EMI
INTC1	LVF	TBF	ADF	T1AF	LVE	TBE	ADE	T1AE

Interrupt Register Contents – HT66F14

Name	Bit							
	7	6	5	4	3	2	1	0
INTEG	—	—	—	—	INT1S1	INT1S0	INT0S1	INT0S0
INTC0	—	MF0F	INT1F	INT0F	MF0E	INT1E	INT0E	EMI
INTC1	LVF	TBF	ADF	MF1F	LVE	TBE	ADE	MF1E
MF10	—	—	T0AF	T0PF	—	—	T0AE	T0PE
MF11	—	—	T1AF	T1PF	—	—	T1AE	T1PE

Interrupt Register Contents – HT66F15

Name	Bit							
	7	6	5	4	3	2	1	0
INTEG	—	—	—	—	INT1S1	INT1S0	INT0S1	INT0S0
INTC0	—	MF0F	INT1F	INT0F	MF0E	INT1E	INT0E	EMI
INTC1	LVF	TBF	ADF	MF1F	LVE	TBE	ADE	MF1E
MF10	—	—	T0AF	T0PF	—	—	T0AE	T0PE
MF11	—	T1BF	T1AF	T1PF	—	T1BE	T1AE	T1PE

INTEG Register – HT66F13/HT66F14/HT66F15

Bit	7	6	5	4	3	2	1	0
Name	—	—	—	—	INT1S1	INT1S0	INT0S1	INT0S0
R/W	—	—	—	—	R/W	R/W	R/W	R/W
POR	—	—	—	—	0	0	0	0

Bit 7~4 unimplemented, read as "0"

Bit 3~2 **INT1S1, INT1S0**: interrupt edge control for INT1 pin
 00: disable
 01: rising edge
 10: falling edge
 11: both rising and falling edges

Bit 1~0 **INT0S1, INT0S0**: interrupt edge control for INT0 pin
 00: disable
 01: rising edge
 10: falling edge
 11: both rising and falling edges

INTC0 Register – HT66F13

Bit	7	6	5	4	3	2	1	0
Name	—	T1PF	INT1F	INT0F	T1PE	INT1E	INT0E	EMI
R/W	—	R/W	R/W	R/W	R/W	R/W	R/W	R/W
POR	—	0	0	0	0	0	0	0

- Bit 7 unimplemented, read as "0"
- Bit 6 **T1PF**: TM1 Comparator P match interrupt request flag
0: no request
1: interrupt request
- Bit 5 **INT1F**: INT1 interrupt request flag
0: no request
1: interrupt request
- Bit 4 **INT0F**: INT0 interrupt request flag
0: no request
1: interrupt request
- Bit 3 **T1PE**: TM1 Comparator P match interrupt control
0: disable
1: enable
- Bit 2 **INT1E**: INT1 interrupt control
0: disable
1: enable
- Bit 1 **INT0E**: INT0 interrupt control
0: disable
1: enable
- Bit 0 **EMI**: Global interrupt control
0: disable
1: enable

INTC0 Register – HT66F14/HT66F15

Bit	7	6	5	4	3	2	1	0
Name	—	MF0F	INT1F	INT0F	MF0E	INT1E	INT0E	EMI
R/W	—	R/W	R/W	R/W	R/W	R/W	R/W	R/W
POR	—	0	0	0	0	0	0	0

- Bit 7 unimplemented, read as "0"
- Bit 6 **MF0F**: Multi-function 0 Interrupt request flag
0: no request
1: interrupt request
- Bit 5 **INT1F**: INT1 interrupt request flag
0: no request
1: interrupt request
- Bit 4 **INT0F**: INT0 interrupt request flag
0: no request
1: interrupt request
- Bit 3 **MF0E**: Multi-function 0 Interrupt control
0: disable
1: enable
- Bit 2 **INT1E**: INT1 interrupt control
0: disable
1: enable
- Bit 1 **INT0E**: INT0 interrupt control
0: disable
1: enable
- Bit 0 **EMI**: Global interrupt control
0: disable
1: enable

INTC1 Register – HT66F13

Bit	7	6	5	4	3	2	1	0
Name	LVF	TBF	ADF	T1AF	LVE	TBE	ADE	T1AE
R/W	R/W	R/W	R/W	R/W	R/W	R/W	R/W	R/W
POR	0	0	0	0	0	0	0	0

- Bit 7 **LVF:** LVD Interrupt request flag
0: no request
1: interrupt request
- Bit 6 **TBF:** Time Base Interrupt request flag
0: no request
1: interrupt request
- Bit 5 **ADF:** A/D Converter interrupt request flag
0: no request
1: interrupt request
- Bit 4 **T1AF:** TM1 Comparator A match Interrupt request flag
0: no request
1: interrupt request
- Bit 3 **LVE:** LVD interrupt control
0: disable
1: enable
- Bit 2 **TBE:** Time Base interrupt control
0: disable
1: enable
- Bit 1 **ADE:** A/D Converter interrupt control
0: disable
1: enable
- Bit 0 **T1AE:** TM1 Comparator A match Interrupt control
0: disable
1: enable

INTC1 Register – HT66F14/HT66F15

Bit	7	6	5	4	3	2	1	0
Name	LVF	TBF	ADF	MF1F	LVE	TBE	ADE	MF1E
R/W	R/W	R/W	R/W	R/W	R/W	R/W	R/W	R/W
POR	0	0	0	0	0	0	0	0

- Bit 7 **LVF:** LVD Interrupt request flag
0: no request
1: interrupt request
- Bit 6 **TBF:** Time Base Interrupt request flag
0: no request
1: interrupt request
- Bit 5 **ADF:** A/D Converter interrupt request flag
0: no request
1: interrupt request
- Bit 4 **MF1F:** Multi-function 1 Interrupt request flag
0: no request
1: interrupt request
- Bit 3 **LVE:** LVD interrupt control
0: disable
1: enable
- Bit 2 **TBE:** Time Base interrupt control
0: disable
1: enable
- Bit 1 **ADE:** A/D Converter interrupt control
0: disable
1: enable
- Bit 0 **MF1E:** Multi-function 1 Interrupt control
0: disable
1: enable

MF10 Register – HT66F14/HT66F15

Bit	7	6	5	4	3	2	1	0
Name	—	—	T0AF	T0PF	—	—	T0AE	T0PE
R/W	—	—	R/W	R/W	—	—	R/W	R/W
POR	—	—	0	0	—	—	0	0

- Bit 7~6 unimplemented, read as "0"
- Bit 5 **T0AF**: TM0 Comparator A match interrupt request flag
0: no request
1: interrupt request
- Bit 4 **T0PF**: TM0 Comparator P match interrupt request flag
0: no request
1: interrupt request
- Bit 3~2 unimplemented, read as "0"
- Bit 1 **T0AE**: TM0 Comparator A match interrupt control
0: disable
1: enable
- Bit 0 **T0PE**: TM0 Comparator P match interrupt control
0: disable
1: enable

MF11 Register – HT66F14

Bit	7	6	5	4	3	2	1	0
Name	—	—	T1AF	T1PF	—	—	T1AE	T1PE
R/W	—	—	R/W	R/W	—	—	R/W	R/W
POR	—	—	0	0	—	—	0	0

- Bit 7~6 unimplemented, read as "0"
- Bit 5 **T1AF**: TM1 Comparator A match interrupt request flag
0: no request
1: interrupt request
- Bit 4 **T1PF**: TM1 Comparator P match interrupt request flag
0: no request
1: interrupt request
- Bit 3~2 unimplemented, read as "0"
- Bit 1 **T1AE**: TM1 Comparator A match interrupt control
0: disable
1: enable
- Bit 0 **T1PE**: TM1 Comparator P match interrupt control
0: disable
1: enable

MF11 Register – HT66F15

Bit	7	6	5	4	3	2	1	0
Name	—	T1BF	T1AF	T1PF	—	T1BE	T1AE	T1PE
R/W	—	R/W	R/W	R/W	—	R/W	R/W	R/W
POR	—	0	0	0	—	0	0	0

- Bit 7 unimplemented, read as "0"
- Bit 6 **T1BF**: TM1 Comparator B match Interrupt request flag
0: no request
1: interrupt request
- Bit 5 **T1AF**: TM1 Comparator A match interrupt request flag
0: no request
1: interrupt request
- Bit 4 **T1PF**: TM1 Comparator P match interrupt request flag
0: no request
1: interrupt request
- Bit 3 unimplemented, read as "0"
- Bit 2 **T1BE**: TM1 Comparator B match interrupt control
0: disable
1: enable
- Bit 1 **T1AE**: TM1 Comparator A match interrupt control
0: disable
1: enable
- Bit 0 **T1PE**: TM1 Comparator P match interrupt control
0: disable
1: enable

Interrupt Operation

When the conditions for an interrupt event occur, such as a TM Comparator P, Comparator A or Comparator B match or A/D conversion completion, etc., the relevant interrupt request flag will be set. Whether the request flag actually generates a program jump to the relevant interrupt vector is determined by the condition of the interrupt enable bit. If the enable bit is set high then the program will jump to its relevant vector; if the enable bit is zero then although the interrupt request flag is set an actual interrupt will not be generated and the program will not jump to the relevant interrupt vector. The global interrupt enable bit, if cleared to zero, will disable all interrupts.

When an interrupt is generated, the Program Counter, which stores the address of the next instruction to be executed, will be transferred onto the stack. The Program Counter will then be loaded with a new address which will be the value of the corresponding interrupt vector. The microcontroller will then fetch its next instruction from this interrupt vector. The instruction at this vector will usually be a "JMP" which will jump to another section of program which is known as the interrupt service routine. Here is located the code to control the appropriate interrupt. The interrupt service routine must be terminated with a "RETI", which retrieves the original Program Counter address from the stack and allows the microcontroller to continue with normal execution at the point where the interrupt occurred.

The various interrupt enable bits, together with their associated request flags, are shown in the accompanying diagrams with their order of priority. Some interrupt sources have their own individual vector while others share the same multi-function interrupt vector. Once an interrupt subroutine is serviced, all the other interrupts will be blocked, as the global interrupt enable bit, EMI bit will be cleared automatically. This will prevent any further interrupt nesting from occurring. However, if other interrupt requests occur during this interval, although the interrupt will not be immediately serviced, the request flag will still be recorded.

If an interrupt requires immediate servicing while the program is already in another interrupt service routine, the EMI bit should be set after entering the routine, to allow interrupt nesting. If the stack is full, the interrupt request will not be acknowledged, even if the related interrupt is enabled, until the Stack Pointer is decremented. If immediate service is desired, the stack must be prevented from becoming full. In case of simultaneous requests, the accompanying diagram shows the priority that is applied. All of the interrupt request flags when set will wake-up the device if it is in SLEEP or IDLE Mode, however to prevent a wake-up from occurring the corresponding flag should be set before the device is in SLEEP or IDLE Mode.

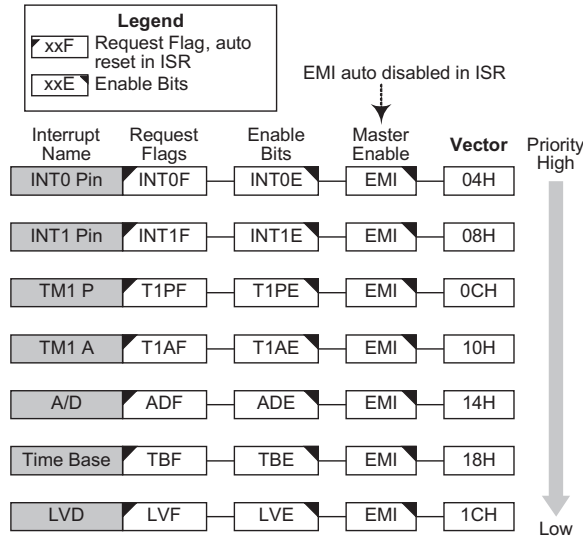

Interrupt Structure – HT66F13

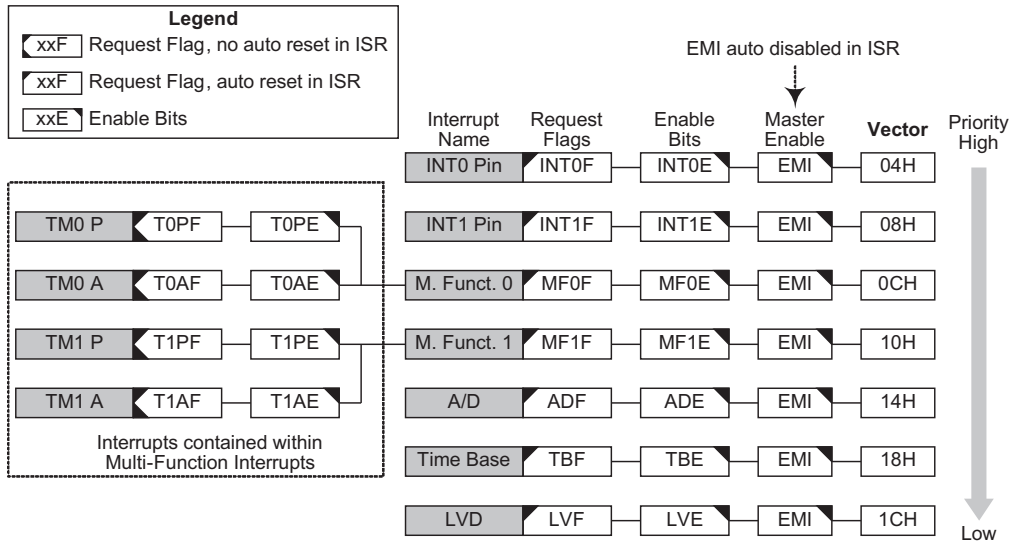

Interrupt Structure – HT66F14

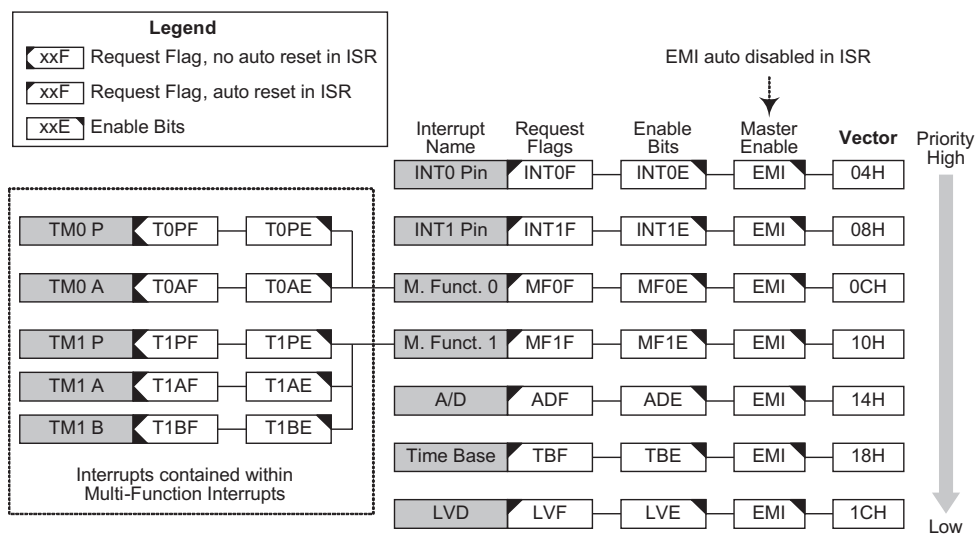

Interrupt Structure – HT66F15

External Interrupt

The external interrupts are controlled by signal transitions on the pins INT0~INT1. An external interrupt request will take place when the external interrupt request flags, INT0F~INT1F, are set, which will occur when a transition, whose type is chosen by the edge select bits, appears on the external interrupt pins. To allow the program to branch to its respective interrupt vector address, the global interrupt enable bit, EMI, and respective external interrupt enable bit, INT0E~INT1E, must first be set. Additionally the correct interrupt edge type must be selected using the INTEG register to enable the external interrupt function and to choose the trigger edge type. As the external interrupt pins are pin-shared with I/O pins, they can only be configured as external interrupt pins if their external interrupt enable bit in the corresponding interrupt register has been set. The pin must also be setup as an input by setting the corresponding bit in the port control register. When the interrupt is enabled, the stack is not full and the correct transition type appears on the external interrupt pin, a subroutine call to the external interrupt vector, will take place. When the interrupt is serviced, the external interrupt request flags, INT0F~INT1F, will be automatically reset and the EMI bit will be automatically cleared to disable other interrupts. Note that any pull-high resistor selections on the external interrupt pins will remain valid even if the pin is used as an external interrupt input.

The INTEG register is used to select the type of active edge that will trigger the external interrupt. A choice of either rising or falling or both edge types can be chosen to trigger an external interrupt. Note that the INTEG register can also be used to disable the external interrupt function.

Multi-function Interrupt

Within these devices there are up to six Multi-function interrupts. Unlike the other independent interrupts, these interrupts have no independent source, but rather are formed from other existing interrupt sources, namely the TM Interrupts.

A Multi-function interrupt request will take place when any of the Multi-function interrupt request flags, MF0F~MF1F are set. The Multi-function interrupt flags will be set when any of their included functions generate an interrupt request flag. To allow the program to branch to its respective interrupt vector address, when the Multi-function interrupt is enabled and the stack is not full, and either one of the interrupts contained within each of Multi-function interrupt occurs, a subroutine call to one of the Multi-function interrupt vectors will take place. When the interrupt is serviced, the related Multi-Function request flag, will be automatically reset and the EMI bit will be automatically cleared to disable other interrupts.

However, it must be noted that, although the Multi-function Interrupt flags will be automatically reset when the interrupt is serviced, the request flags from the original source of the Multi-function interrupts, namely the TM Interrupts, will not be automatically reset and must be manually reset by the application program.

A/D Converter Interrupt

The A/D Converter Interrupt is controlled by the termination of an A/D conversion process. An A/D Converter Interrupt request will take place when the A/D Converter Interrupt request flag, ADF, is set, which occurs when the A/D conversion process finishes. To allow the program to branch to its respective interrupt vector address, the global interrupt enable bit, EMI, and A/D Interrupt enable bit, ADE, must first be set. When the interrupt is enabled, the stack is not full and the A/D conversion process has ended, a subroutine call to the A/D Converter Interrupt vector, will take place. When the interrupt is serviced, the A/D Converter Interrupt flag, ADF, will be automatically cleared. The EMI bit will also be automatically cleared to disable other interrupts.

Time Base Interrupts

The function of the Time Base Interrupt is to provide regular time signal in the form of an internal interrupt. It is controlled by the overflow signal from the respective timer function. When this happens, the respective interrupt request flags TBF will be set. To allow the program to branch to their respective interrupt vector addresses, the global interrupt enable bit EMI and Time Base enable bit TBE must first be set. When the interrupt is enabled, the stack is not full and the Time Base overflows, a subroutine call to their respective vector locations will take place. When the interrupt is serviced, the respective interrupt request flag TBF will be automatically reset and the EMI bit will be cleared to disable other interrupts.

The purpose of the Time Base Interrupt is to provide an interrupt signal at fixed time periods. Their clock sources originate from the internal clock source f_{TB} . This f_{TB} input clock passes through a divider, the division ratio of which is selected by programming the appropriate bits in the TBC register to obtain longer interrupt periods whose value ranges. The clock source that generates f_{TB} , which in turn controls the Time Base interrupt period, can originate from several different sources, as shown in the System Operating Mode section.

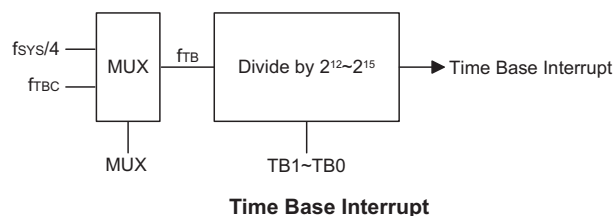

Note: The f_{TBC} is from the LIRC oscillator.

TBC Register

Bit	7	6	5	4	3	2	1	0
Name	TBON	TBCK	TB1	TB0	—	—	—	—
R/W	R/W	R/W	R/W	R/W	—	—	—	—
POR	0	0	1	1	—	—	—	—

- Bit 7 **TBON**: Time Base control
0: disable
1: enable
- Bit 6 **TBCK**: Time Base clock f_{TB} selection
0: f_{TBC}
1: $f_{SYS}/4$
- Bit 5~4 **TB1~TB0**: Select Time Base Time-out Period
00: $4096/f_{TB}$
01: $8192/f_{TB}$
10: $16384/f_{TB}$
11: $32768/f_{TB}$
- Bit 3~0 unimplemented, read as "0"

LVD Interrupt

The Low Voltage Detector Interrupt is contained within the Multi-function Interrupt. A LVD Interrupt request will take place when the LVD Interrupt request flag, LVF, is set, which occurs when the Low Voltage Detector function detects a low power supply voltage. To allow the program to branch to its respective interrupt vector address, the global interrupt enable bit, EMI, Low Voltage Interrupt enable bit, LVE, and associated Multi-function interrupt enable bit, must first be set. When the interrupt is enabled, the stack is not full and a low voltage condition occurs, a subroutine call to the Multi-function Interrupt vector, will take place. When the Low Voltage Interrupt is serviced, the EMI bit will be automatically cleared to disable other interrupts, however only the Multi-function interrupt request flag will be also automatically cleared. As the LVF flag will not be automatically cleared, it has to be cleared by the application program.

TM Interrupts

The Compact and Standard Type TMs have two interrupts each, while the Enhanced Type TM has three interrupts. All of the TM interrupts are contained within the Multi-function Interrupts in these devices except HT66F13. For each of the Compact and Standard Type TMs there are two interrupt request flags TnPF and TnAF and two enable bits TnPE and TnAE. For the Enhanced Type TM there are three interrupt request flags TnPF, TnAF and TnBF and three enable bits TnPE, TnAE and TnBE. A TM interrupt request will take place when any of the TM request flags are set, a situation which occurs when a TM comparator P, A or B match situation happens.

To allow the program to branch to its respective interrupt vector address, the global interrupt enable bit, EMI, respective TM Interrupt enable bit, and relevant Multi-function Interrupt enable bit, MFnE, must first be set. When the interrupt is enabled, the stack is not full and a TM comparator match situation occurs, a subroutine call to the relevant Multi-function Interrupt vector locations, will take place. When the TM interrupt is serviced, the EMI bit will be automatically cleared to disable other interrupts, however only the related MFnF flag will be automatically cleared. As the TM interrupt request flags will not be automatically cleared, they have to be cleared by the application program.

Interrupt Wake-up Function

Each of the interrupt functions has the capability of waking up the microcontroller when in the SLEEP or IDLE Mode. A wake-up is generated when an interrupt request flag changes from low to high and is independent of whether the interrupt is enabled or not. Therefore, even though the device is in the SLEEP or IDLE Mode and its system oscillator stopped, situations such as external edge transitions on the external interrupt pins, a low power supply voltage or comparator input change may cause their respective interrupt flag to be set high and consequently generate an interrupt. Care must therefore be taken if spurious wake-up situations are to be avoided. If an interrupt wake-up function is to be disabled then the corresponding interrupt request flag should be set high before the device enters the SLEEP or IDLE Mode. The interrupt enable bits have no effect on the interrupt wake-up function.

Programming Considerations

By disabling the relevant interrupt enable bits, a requested interrupt can be prevented from being serviced, however, once an interrupt request flag is set, it will remain in this condition in the interrupt register until the corresponding interrupt is serviced or until the request flag is cleared by the application program.

Where a certain interrupt is contained within a Multi-function interrupt, then when the interrupt service routine is executed, as only the Multi-function interrupt request flags, MF0F~MF1F, will be automatically cleared, the individual request flag for the function needs to be cleared by the application program.

It is recommended that programs do not use the "CALL" instruction within the interrupt service subroutine. Interrupts often occur in an unpredictable manner or need to be serviced immediately. If only one stack is left and the interrupt is not well controlled, the original control sequence will be damaged once a CALL subroutine is executed in the interrupt subroutine.

Every interrupt has the capability of waking up the microcontroller when it is in SLEEP or IDLE Mode, the wake up being generated when the interrupt request flag changes from low to high. If it is required to prevent a certain interrupt from waking up the microcontroller then its respective request flag should be first set high before enter SLEEP or IDLE Mode.

As only the Program Counter is pushed onto the stack, then when the interrupt is serviced, if the contents of the accumulator, status register or other registers are altered by the interrupt service program, their contents should be saved to the memory at the beginning of the interrupt service routine.

To return from an interrupt subroutine, either a "RET" or "RETI" instruction may be executed. The RETI instruction in addition to executing a return to the main program also automatically sets the EMI bit high to allow further interrupts. The RET instruction however only executes a return to the main program leaving the EMI bit in its present zero state and therefore disabling the execution of further interrupts.

Power Down Mode and Wake-up

Entering the IDLE or SLEEP Mode

There is only one way for the device to enter the SLEEP or IDLE Mode and that is to execute the "HALT" instruction in the application program. When this instruction is executed, the following will occur:

- The system clock will be stopped and the application program will stop at the HALT instruction.
- The Data Memory contents and registers will maintain their present condition.
- The WDT will be cleared and resume counting if the WDT clock source is selected to come from the f_{SUB} clock source and the WDT is enabled. The WDT will stop if its clock source originates from the system clock.
- The I/O ports will maintain their present condition.
- In the status register, the Power Down flag, PDF, will be set and the Watchdog time-out flag, TO, will be cleared.

Standby Current Considerations

As the main reason for entering the SLEEP or IDLE Mode is to keep the current consumption of the device to as low a value as possible, perhaps only in the order of several micro-amps, there are other considerations which must also be taken into account by the circuit designer if the power consumption is to be minimised. Special attention must be made to the I/O pins on the device. All high-impedance input pins must be connected to either a fixed high or low level as any floating input pins could create internal oscillations and result in increased current consumption. This also applies to devices which have different package types, as there may be unbonded pins. These must either be setup as outputs or if setup as inputs must have pull-high resistors connected. Care must also be taken with the loads, which are connected to I/O pins, which are setup as outputs. These should be placed in a condition in which minimum current is drawn or connected only to external circuits that do not draw current, such as other CMOS inputs. Also note that additional standby current will also be required if the configuration options have enabled the LIRC oscillator.

Wake-up

After the system enters the SLEEP or IDLE Mode, it can be woken up from one of various sources listed as follows:

- An external reset
- An external falling edge on Port A
- A system interrupt
- A WDT overflow

If the system is woken up by an external reset, the device will experience a full system reset, however, if the device is woken up by a WDT overflow, a Watchdog Timer reset will be initiated. Although both of these wake-up methods will initiate a reset operation, the actual source of the wake-up can be determined by examining the TO and PDF flags. The PDF flag is cleared by a system power-up or executing the clear Watchdog Timer instructions and is set when executing the HALT instruction. The TO flag is set if a WDT time-out occurs, and causes a wake-up that only resets the Program Counter and Stack Pointer, the other flags remain in their original status.

Each pin on Port A can be setup using the PAWU register to permit a negative transition on the pin to wake-up the system. When a Port A pin wake-up occurs, the program will resume execution at the instruction following the "HALT" instruction.

If the system is woken up by an interrupt, then two possible situations may occur. The first is where the related interrupt is disabled or the interrupt is enabled but the stack is full, in which case the program will resume execution at the instruction following the HALT instruction. In this situation, the interrupt which woke-up the device will not be immediately serviced, but will rather be serviced later when the related interrupt is finally enabled or when a stack level becomes free. The other situation is where the related interrupt is enabled and the stack is not full, in which case the regular interrupt response takes place. If an interrupt request flag is set high before entering the SLEEP or IDLE Mode, the wake-up function of the related interrupt will be disabled.

Low Voltage Detector – LVD

Each device has a Low Voltage Detector function, also known as LVD. This enabled the device to monitor the power supply voltage, V_{DD} , and provide a warning signal should it fall below a certain level. This function may be especially useful in battery applications where the supply voltage will gradually reduce as the battery ages, as it allows an early warning battery low signal to be generated. The Low Voltage Detector also has the capability of generating an interrupt signal.

LVD Register

The Low Voltage Detector function is controlled using a single register with the name LVDC. Three bits in this register, VLVD2~VLVD0, are used to select one of eight fixed voltages below which a low voltage condition will be determined. A low voltage condition is indicated when the LVDO bit is set. If the LVDO bit is low, this indicates that the V_{DD} voltage is above the preset low voltage value. The LVDEN bit is used to control the overall on/off function of the low voltage detector. Setting the bit high will enable the low voltage detector. Clearing the bit to zero will switch off the internal low voltage detector circuits. As the low voltage detector will consume a certain amount of power, it may be desirable to switch off the circuit when not in use, an important consideration in power sensitive battery powered applications.

LVDC Register

Bit	7	6	5	4	3	2	1	0
Name	—	—	LVDO	LVDEN	—	VLVD2	VLVD1	VLVD0
R/W	—	—	R	R/W	—	R/W	R/W	R/W
POR	—	—	0	0	—	0	0	0

- Bit 7~6 unimplemented, read as "0"
- Bit 5 **LVDO**: LVD Output Flag
0: no low voltage detect
1: low voltage detect
- Bit **LVDEN**: low voltage detector control
0: disable
1: enable
- Bit 3 unimplemented, read as "0"
- Bit 2~0 **VLVD2 ~ VLVD0**: select LVD voltage
000: 2.0V
001: 2.2V
010: 2.4V
011: 2.7V
100: 3.0V
101: 3.3V
110: 3.6V
111: 4.4V

LVD Operation

The Low Voltage Detector function operates by comparing the power supply voltage, V_{DD} , with a pre-specified voltage level stored in the LVDC register. This has a range of between 2.0V and 4.4V. When the power supply voltage, V_{DD} , falls below this pre-determined value, the LVDO bit will be set high indicating a low power supply voltage condition. The Low Voltage Detector function is supplied by a reference voltage which will be automatically enabled. When the device is powered down the low voltage detector will remain active if the LVDEN bit is high. After enabling the Low Voltage Detector, a time delay t_{LVDS} should be allowed for the circuitry to stabilise before reading the LVDO bit. Note also that as the V_{DD} voltage may rise and fall rather slowly, at the voltage nears that of V_{LVD} , there may be multiple bit LVDO transitions.

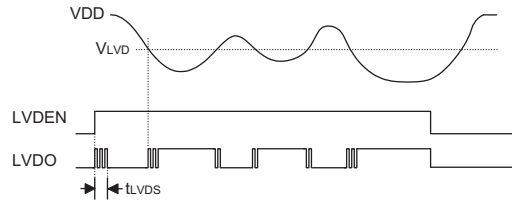

LVD Operation

The Low Voltage Detector also has its own interrupt which is contained within one of the Multi-function interrupts, providing an alternative means of low voltage detection, in addition to polling the LVDO bit. The interrupt will only be generated after a delay of t_{LVD} after the LVDO bit has been set high by a low voltage condition. When the device is powered down the Low Voltage Detector will remain active if the LVDEN bit is high. In this case, the LVF interrupt request flag will be set, causing an interrupt to be generated if V_{DD} falls below the preset LVD voltage. This will cause the device to wake-up from the SLEEP or IDLE Mode, however if the Low Voltage Detector wake up function is not required then the LVF flag should be first set high before the device enters the SLEEP or IDLE Mode.

SCOM Function for LCD

The devices have the capability of driving external LCD panels. The common pins for LCD driving, SCOM0~ SCOM3, are pin shared with certain pin on the PC0~PC1 and PB6 ~ PB7 pins. The LCD signals (COM and SEG) are generated using the application program.

LCD Operation

An external LCD panel can be driven using this device by configuring the PC0~PC1 or PB6 ~ PB7 pins as common pins and using other output ports lines as segment pins. The LCD driver function is controlled using the SCOMC register which in addition to controlling the overall on/off function also controls the bias voltage setup function. This enables the LCD COM driver to generate the necessary $V_{DD}/2$ voltage levels for LCD 1/2 bias operation.

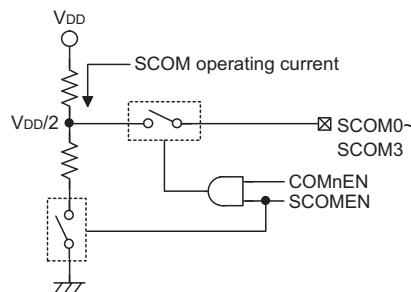

LCD COM Bias

The SCOMEN bit in the SCOMC register is the overall master control for the LCD driver; however this bit is used in conjunction with the COMnEN bits to select which Port C pins are used for LCD driving. Note that the Port Control register does not need to first setup the pins as outputs to enable the LCD driver operation.

SCOMEN	COMnEN	Pin Function	O/P Level
0	X	I/O	0 or 1
1	0	I/O	0 or 1
1	1	SCOMn	V _{DD} /2

Output Control

LCD Bias Control

The LCD COM driver enables a range of selections to be provided to suit the requirement of the LCD panel which is being used. The bias resistor choice is implemented using the ISEL1 and ISEL0 bits in the SCOMC register.

SCOMC Register

Bit	7	6	5	4	3	2	1	0
Name	D7	ISEL1	ISEL0	SCOMEN	COM3EN	COM2EN	COM1EN	COM0EN
R/W	R/W	R/W	R/W	R/W	R/W	R/W	R/W	R/W
POR	0	0	0	0	0	0	0	0

- Bit 7 **Reserved Bit**
0: Correct level - bit must be reset to zero for correct operation
1: Unpredictable operation - bit must not be set high
- Bit 6~5 **ISEL1, ISEL0:** ISEL1 ~ ISEL0: Select SCOM typical bias current (V_{DD}=5V)
00: 25μA
01: 50μA
10: 100μA
11: 200μA
- Bit 4 **SCOMEN:** SCOM module control
0: disable
1: enable
- Bit 3 **COM3EN:** GPIO or SCOM3 selection
0: GPIO
1: SCOM3
- Bit 2 **COM2EN:** GPIO or SCOM2 selection
0: GPIO
1: SCOM2
- Bit 1 **COM1EN:** GPIO or SCOM1 selection
0: GPIO
1: SCOM1
- Bit 0 **COM0EN:** GPIO or SCOM0 selection
0: GPIO
1: SCOM0

Configuration Options

Configuration options refer to certain options within the MCU that are programmed into the device during the programming process. During the development process, these options are selected using the HT-IDE software development tools. As these options are programmed into the device using the hardware programming tools, once they are selected they cannot be changed later using the application program. All options must be defined for proper system function, the details of which are shown in the table.

No.	Options
Oscillator Options	
1	High Speed System Oscillator Selection - f_H : HXT, ERC, HIRC
2	High Speed Internal RC Frequency Selection: 4MHz, 8MHz or 12MHz
Reset Pin Options	
3	Pin function: $\overline{\text{RES}}$ or PB3
Watchdog Options	
4	Watchdog Timer: enable or disable
5	Watchdog Timer clock source Selection: f_{SUB} or $f_{\text{SYS}}/4$ Note: The f_{SUB} and the f_{TBC} clock source are the LIRC oscillator.
6	CLRWDT instructions: 1 or 2 instructions
LVR Options	
7	LVR function: enable or disable
8	LVR voltage: 2.10V, 2.55V, 3.15V or 4.2V

Application Circuits

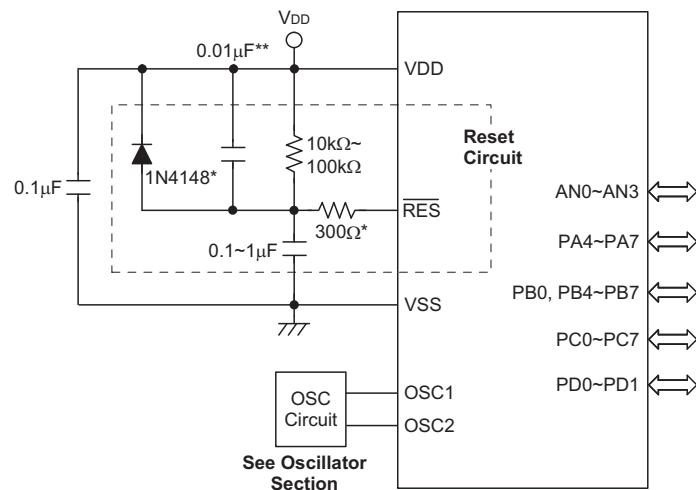

Note: "*" It is recommended that this component is added for added ESD protection.

**** It is recommended that this component is added in environments where power line noise is significant.

Instruction Set

Introduction

Central to the successful operation of any microcontroller is its instruction set, which is a set of program instruction codes that directs the microcontroller to perform certain operations. In the case of Holtek microcontrollers, a comprehensive and flexible set of over 60 instructions is provided to enable programmers to implement their application with the minimum of programming overheads.

For easier understanding of the various instruction codes, they have been subdivided into several functional groupings.

Instruction Timing

Most instructions are implemented within one instruction cycle. The exceptions to this are branch, call, or table read instructions where two instruction cycles are required. One instruction cycle is equal to 4 system clock cycles, therefore in the case of an 8MHz system oscillator, most instructions would be implemented within 0.5 μ s and branch or call instructions would be implemented within 1 μ s. Although instructions which require one more cycle to implement are generally limited to the JMP, CALL, RET, RETI and table read instructions, it is important to realize that any other instructions which involve manipulation of the Program Counter Low register or PCL will also take one more cycle to implement. As instructions which change the contents of the PCL will imply a direct jump to that new address, one more cycle will be required. Examples of such instructions would be "CLR PCL" or "MOV PCL, A". For the case of skip instructions, it must be noted that if the result of the comparison involves a skip operation then this will also take one more cycle, if no skip is involved then only one cycle is required.

Moving and Transferring Data

The transfer of data within the microcontroller program is one of the most frequently used operations. Making use of three kinds of MOV instructions, data can be transferred from registers to the Accumulator and vice-versa as well as being able to move specific immediate data directly into the Accumulator. One of the most important data transfer applications is to receive data from the input ports and transfer data to the output ports.

Arithmetic Operations

The ability to perform certain arithmetic operations and data manipulation is a necessary feature of most microcontroller applications. Within the Holtek microcontroller instruction set are a range of add and subtract instruction mnemonics to enable the necessary arithmetic to be carried out. Care must be taken to ensure correct handling of carry and borrow data when results exceed 255 for addition and less than 0 for subtraction. The increment and decrement instructions INC, INCA, DEC and DECA provide a simple means of increasing or decreasing by a value of one of the values in the destination specified.

Logical and Rotate Operations

The standard logical operations such as AND, OR, XOR and CPL all have their own instruction within the Holtek microcontroller instruction set. As with the case of most instructions involving data manipulation, data must pass through the Accumulator which may involve additional programming steps. In all logical data operations, the zero flag may be set if the result of the operation is zero. Another form of logical data manipulation comes from the rotate instructions such as RR, RL, RRC and RLC which provide a simple means of rotating one bit right or left. Different rotate instructions exist depending on program requirements. Rotate instructions are useful for serial port programming applications where data can be rotated from an internal register into the Carry bit from where it can be examined and the necessary serial bit set high or low. Another application where rotate data operations are used is to implement multiplication and division calculations.

Branches and Control Transfer

Program branching takes the form of either jumps to specified locations using the JMP instruction or to a subroutine using the CALL instruction. They differ in the sense that in the case of a subroutine call, the program must return to the instruction immediately when the subroutine has been carried out. This is done by placing a return instruction RET in the subroutine which will cause the program to jump back to the address right after the CALL instruction. In the case of a JMP instruction, the program simply jumps to the desired location. There is no requirement to jump back to the original jumping off point as in the case of the CALL instruction. One special and extremely useful set of branch instructions are the conditional branches. Here a decision is first made regarding the condition of a certain data memory or individual bits. Depending upon the conditions, the program will continue with the next instruction or skip over it and jump to the following instruction. These instructions are the key to decision making and branching within the program perhaps determined by the condition of certain input switches or by the condition of internal data bits.

Bit Operations

The ability to provide single bit operations on Data Memory is an extremely flexible feature of all Holtek microcontrollers. This feature is especially useful for output port bit programming where individual bits or port pins can be directly set high or low using either the "SET [m].i" or "CLR [m].i" instructions respectively. The feature removes the need for programmers to first read the 8-bit output port, manipulate the input data to ensure that other bits are not changed and then output the port with the correct new data. This read-modify-write process is taken care of automatically when these bit operation instructions are used.

Table Read Operations

Data storage is normally implemented by using registers. However, when working with large amounts of fixed data, the volume involved often makes it inconvenient to store the fixed data in the Data Memory. To overcome this problem, Holtek microcontrollers allow an area of Program Memory to be setup as a table where data can be directly stored. A set of easy to use instructions provides the means by which this fixed data can be referenced and retrieved from the Program Memory.

Other Operations

In addition to the above functional instructions, a range of other instructions also exist such as the "HALT" instruction for Power-down operations and instructions to control the operation of the Watchdog Timer for reliable program operations under extreme electric or electromagnetic environments. For their relevant operations, refer to the functional related sections.

Instruction Set Summary

The following table depicts a summary of the instruction set categorised according to function and can be consulted as a basic instruction reference using the following listed conventions.

Table conventions:

x: Bits immediate data

m: Data Memory address

A: Accumulator

i: 0~7 number of bits

addr: Program memory address

Mnemonic	Description	Cycles	Flag Affected
Arithmetic			
ADD A,[m]	Add Data Memory to ACC	1	Z, C, AC, OV
ADDM A,[m]	Add ACC to Data Memory	↑Note	Z, C, AC, OV
ADD A,x	Add immediate data to ACC	1	Z, C, AC, OV
ADC A,[m]	Add Data Memory to ACC with Carry	1	Z, C, AC, OV
ADCM A,[m]	Add ACC to Data memory with Carry	↑Note	Z, C, AC, OV
SUB A,x	Subtract immediate data from the ACC	1	Z, C, AC, OV
SUB A,[m]	Subtract Data Memory from ACC	1	Z, C, AC, OV
SUBM A,[m]	Subtract Data Memory from ACC with result in Data Memory	↑Note	Z, C, AC, OV
SBC A,[m]	Subtract Data Memory from ACC with Carry	1	Z, C, AC, OV
SBCM A,[m]	Subtract Data Memory from ACC with Carry, result in Data Memory	↑Note	Z, C, AC, OV
DAA [m]	Decimal adjust ACC for Addition with result in Data Memory	↑Note	C
Logic Operation			
AND A,[m]	Logical AND Data Memory to ACC	1	Z
OR A,[m]	Logical OR Data Memory to ACC	1	Z
XOR A,[m]	Logical XOR Data Memory to ACC	1	Z
ANDM A,[m]	Logical AND ACC to Data Memory	↑Note	Z
ORM A,[m]	Logical OR ACC to Data Memory	↑Note	Z
XORM A,[m]	Logical XOR ACC to Data Memory	↑Note	Z
AND A,x	Logical AND immediate Data to ACC	1	Z
OR A,x	Logical OR immediate Data to ACC	1	Z
XOR A,x	Logical XOR immediate Data to ACC	1	Z
CPL [m]	Complement Data Memory	↑Note	Z
CPLA [m]	Complement Data Memory with result in ACC	1	Z
Increment & Decrement			
INCA [m]	Increment Data Memory with result in ACC	1	Z
INC [m]	Increment Data Memory	↑Note	Z
DECA [m]	Decrement Data Memory with result in ACC	1	Z
DEC [m]	Decrement Data Memory	↑Note	Z
Rotate			
RRA [m]	Rotate Data Memory right with result in ACC	1	None
RR [m]	Rotate Data Memory right	↑Note	None
RRCA [m]	Rotate Data Memory right through Carry with result in ACC	1	C
RRC [m]	Rotate Data Memory right through Carry	↑Note	C
RLA [m]	Rotate Data Memory left with result in ACC	1	None
RL [m]	Rotate Data Memory left	↑Note	None
RLCA [m]	Rotate Data Memory left through Carry with result in ACC	1	C
RLC [m]	Rotate Data Memory left through Carry	↑Note	C
Data Move			
MOV A,[m]	Move Data Memory to ACC	1	None
MOV [m],A	Move ACC to Data Memory	↑Note	None
MOV A,x	Move immediate data to ACC	1	None

HT66F13/HT66F14/HT66F15

Enhanced A/D Flash Type MCU



Mnemonic	Description	Cycles	Flag Affected
Bit Operation			
CLR [m].i	Clear bit of Data Memory	1 ^{Note}	None
SET [m].i	Set bit of Data Memory	1 ^{Note}	None
Branch			
JMP addr	Jump unconditionally	2	None
SZ [m]	Skip if Data Memory is zero	1 ^{Note}	None
SZA [m]	Skip if Data Memory is zero with data movement to ACC	1 ^{note}	None
SZ [m].i	Skip if bit i of Data Memory is zero	1 ^{Note}	None
SNZ [m].i	Skip if bit i of Data Memory is not zero	1 ^{Note}	None
SIZ [m]	Skip if increment Data Memory is zero	1 ^{Note}	None
SDZ [m]	Skip if decrement Data Memory is zero	1 ^{Note}	None
SIZA [m]	Skip if increment Data Memory is zero with result in ACC	1 ^{Note}	None
SDZA [m]	Skip if decrement Data Memory is zero with result in ACC	1 ^{Note}	None
CALL addr	Subroutine call	2	None
RET	Return from subroutine	2	None
RET A,x	Return from subroutine and load immediate data to ACC	2	None
RETI	Return from interrupt	2	None
Table Read			
TABRDC [m]	Read table (current page) to TBLH and Data Memory	2 ^{Note}	None
TABRDL [m]	Read table (last page) to TBLH and Data Memory	2 ^{Note}	None
Miscellaneous			
NOP	No operation	1	None
CLR [m]	Clear Data Memory	1 ^{Note}	None
SET [m]	Set Data Memory	1 ^{Note}	None
CLR WDT	Clear Watchdog Timer	1	TO, PDF
CLR WDT1	Pre-clear Watchdog Timer	1	TO, PDF
CLR WDT2	Pre-clear Watchdog Timer	1	TO, PDF
SWAP [m]	Swap nibbles of Data Memory	1 ^{Note}	None
SWAPA [m]	Swap nibbles of Data Memory with result in ACC	1	None
HALT	Enter power down mode	1	TO, PDF

- Note:
1. For skip instructions, if the result of the comparison involves a skip then two cycles are required, if no skip takes place only one cycle is required.
 2. Any instruction which changes the contents of the PCL will also require 2 cycles for execution.
 3. For the "CLR WDT1" and "CLR WDT2" instructions the TO and PDF flags may be affected by the execution status. The TO and PDF flags are cleared after both "CLR WDT1" and "CLR WDT2" instructions are consecutively executed. Otherwise the TO and PDF flags remain unchanged.

Instruction Definition

ADC A,[m]	Add Data Memory to ACC with Carry
Description	The contents of the specified Data Memory, Accumulator and the carry flag are added. The result is stored in the Accumulator.
Operation	$ACC \leftarrow ACC + [m] + C$
Affected flag(s)	OV, Z, AC, C
ADCM A,[m]	Add ACC to Data Memory with Carry
Description	The contents of the specified Data Memory, Accumulator and the carry flag are added. The result is stored in the specified Data Memory.
Operation	$[m] \leftarrow ACC + [m] + C$
Affected flag(s)	OV, Z, AC, C
ADD A,[m]	Add Data Memory to ACC
Description	The contents of the specified Data Memory and the Accumulator are added. The result is stored in the Accumulator.
Operation	$ACC \leftarrow ACC + [m]$
Affected flag(s)	OV, Z, AC, C
ADD A,x	Add immediate data to ACC
Description	The contents of the Accumulator and the specified immediate data are added. The result is stored in the Accumulator.
Operation	$ACC \leftarrow ACC + x$
Affected flag(s)	OV, Z, AC, C
ADDM A,[m]	Add ACC to Data Memory
Description	The contents of the specified Data Memory and the Accumulator are added. The result is stored in the specified Data Memory.
Operation	$[m] \leftarrow ACC + [m]$
Affected flag(s)	OV, Z, AC, C
AND A,[m]	Logical AND Data Memory to ACC
Description	Data in the Accumulator and the specified Data Memory perform a bitwise logical AND operation. The result is stored in the Accumulator.
Operation	$ACC \leftarrow ACC \text{ "AND" } [m]$
Affected flag(s)	Z
AND A,x	Logical AND immediate data to ACC
Description	Data in the Accumulator and the specified immediate data perform a bitwise logical AND operation. The result is stored in the Accumulator.
Operation	$ACC \leftarrow ACC \text{ "AND" } x$
Affected flag(s)	Z
ANDM A,[m]	Logical AND ACC to Data Memory
Description	Data in the specified Data Memory and the Accumulator perform a bitwise logical AND operation. The result is stored in the Data Memory.
Operation	$[m] \leftarrow ACC \text{ "AND" } [m]$
Affected flag(s)	Z

CALL addr	Subroutine call
Description	Unconditionally calls a subroutine at the specified address. The Program Counter then increments by 1 to obtain the address of the next instruction which is then pushed onto the stack. The specified address is then loaded and the program continues execution from this new address. As this instruction requires an additional operation, it is a two cycle instruction.
Operation	Stack \leftarrow Program Counter + 1 Program Counter \leftarrow addr
Affected flag(s)	None
CLR [m]	Clear Data Memory
Description	Each bit of the specified Data Memory is cleared to 0.
Operation	[m] \leftarrow 00H
Affected flag(s)	None
CLR [m].i	Clear bit of Data Memory
Description	Bit i of the specified Data Memory is cleared to 0.
Operation	[m].i \leftarrow 0
Affected flag(s)	None
CLR WDT	Clear Watchdog Timer
Description	The TO, PDF flags and the WDT are all cleared.
Operation	WDT cleared TO \leftarrow 0 PDF \leftarrow 0
Affected flag(s)	TO, PDF
CLR WDT1	Pre-clear Watchdog Timer
Description	The TO, PDF flags and the WDT are all cleared. Note that this instruction works in conjunction with CLR WDT2 and must be executed alternately with CLR WDT2 to have effect. Repetitively executing this instruction without alternately executing CLR WDT2 will have no effect.
Operation	WDT cleared TO \leftarrow 0 PDF \leftarrow 0
Affected flag(s)	TO, PDF
CLR WDT2	Pre-clear Watchdog Timer
Description	The TO, PDF flags and the WDT are all cleared. Note that this instruction works in conjunction with CLR WDT1 and must be executed alternately with CLR WDT1 to have effect. Repetitively executing this instruction without alternately executing CLR WDT1 will have no effect.
Operation	WDT cleared TO \leftarrow 0 PDF \leftarrow 0
Affected flag(s)	TO, PDF

CPL [m]	Complement Data Memory
Description	Each bit of the specified Data Memory is logically complemented (1's complement). Bits which previously contained a 1 are changed to 0 and vice versa.
Operation	$[m] \leftarrow \overline{[m]}$
Affected flag(s)	Z
CPLA [m]	Complement Data Memory with result in ACC
Description	Each bit of the specified Data Memory is logically complemented (1's complement). Bits which previously contained a 1 are changed to 0 and vice versa. The complemented result is stored in the Accumulator and the contents of the Data Memory remain unchanged.
Operation	$ACC \leftarrow \overline{[m]}$
Affected flag(s)	Z
DAA [m]	Decimal-Adjust ACC for addition with result in Data Memory
Description	Convert the contents of the Accumulator value to a BCD (Binary Coded Decimal) value resulting from the previous addition of two BCD variables. If the low nibble is greater than 9 or if AC flag is set, then a value of 6 will be added to the low nibble. Otherwise the low nibble remains unchanged. If the high nibble is greater than 9 or if the C flag is set, then a value of 6 will be added to the high nibble. Essentially, the decimal conversion is performed by adding 00H, 06H, 60H or 66H depending on the Accumulator and flag conditions. Only the C flag may be affected by this instruction which indicates that if the original BCD sum is greater than 100, it allows multiple precision decimal addition.
Operation	$[m] \leftarrow ACC + 00H$ or $[m] \leftarrow ACC + 06H$ or $[m] \leftarrow ACC + 60H$ or $[m] \leftarrow ACC + 66H$
Affected flag(s)	C
DEC [m]	Decrement Data Memory
Description	Data in the specified Data Memory is decremented by 1.
Operation	$[m] \leftarrow [m] - 1$
Affected flag(s)	Z
DECA [m]	Decrement Data Memory with result in ACC
Description	Data in the specified Data Memory is decremented by 1. The result is stored in the Accumulator. The contents of the Data Memory remain unchanged.
Operation	$ACC \leftarrow [m] - 1$
Affected flag(s)	Z
HALT	Enter power down mode
Description	This instruction stops the program execution and turns off the system clock. The contents of the Data Memory and registers are retained. The WDT and prescaler are cleared. The power down flag PDF is set and the WDT time-out flag TO is cleared.
Operation	$TO \leftarrow 0$ $PDF \leftarrow 1$
Affected flag(s)	TO, PDF

INC [m]	Increment Data Memory
Description	Data in the specified Data Memory is incremented by 1.
Operation	$[m] \leftarrow [m] + 1$
Affected flag(s)	Z
INCA [m]	Increment Data Memory with result in ACC
Description	Data in the specified Data Memory is incremented by 1. The result is stored in the Accumulator. The contents of the Data Memory remain unchanged.
Operation	$ACC \leftarrow [m] + 1$
Affected flag(s)	Z
JMP addr	Jump unconditionally
Description	The contents of the Program Counter are replaced with the specified address. Program execution then continues from this new address. As this requires the insertion of a dummy instruction while the new address is loaded, it is a two cycle instruction.
Operation	$Program\ Counter \leftarrow addr$
Affected flag(s)	None
MOV A,[m]	Move Data Memory to ACC
Description	The contents of the specified Data Memory are copied to the Accumulator.
Operation	$ACC \leftarrow [m]$
Affected flag(s)	None
MOV A,x	Move immediate data to ACC
Description	The immediate data specified is loaded into the Accumulator.
Operation	$ACC \leftarrow x$
Affected flag(s)	None
MOV [m],A	Move ACC to Data Memory
Description	The contents of the Accumulator are copied to the specified Data Memory.
Operation	$[m] \leftarrow ACC$
Affected flag(s)	None
NOP	No operation
Description	No operation is performed. Execution continues with the next instruction.
Operation	No operation
Affected flag(s)	None
OR A,[m]	Logical OR Data Memory to ACC
Description	Data in the Accumulator and the specified Data Memory perform a bitwise logical OR operation. The result is stored in the Accumulator.
Operation	$ACC \leftarrow ACC \text{ "OR" } [m]$
Affected flag(s)	Z

OR A,x	Logical OR immediate data to ACC
Description	Data in the Accumulator and the specified immediate data perform a bitwise logical OR operation. The result is stored in the Accumulator.
Operation	$ACC \leftarrow ACC \text{ "OR" } x$
Affected flag(s)	Z
ORM A,[m]	Logical OR ACC to Data Memory
Description	Data in the specified Data Memory and the Accumulator perform a bitwise logical OR operation. The result is stored in the Data Memory.
Operation	$[m] \leftarrow ACC \text{ "OR" } [m]$
Affected flag(s)	Z
RET	Return from subroutine
Description	The Program Counter is restored from the stack. Program execution continues at the restored address.
Operation	Program Counter \leftarrow Stack
Affected flag(s)	None
RET A,x	Return from subroutine and load immediate data to ACC
Description	The Program Counter is restored from the stack and the Accumulator loaded with the specified immediate data. Program execution continues at the restored address.
Operation	Program Counter \leftarrow Stack $ACC \leftarrow x$
Affected flag(s)	None
RETI	Return from interrupt
Description	The Program Counter is restored from the stack and the interrupts are re-enabled by setting the EMI bit. EMI is the master interrupt global enable bit. If an interrupt was pending when the RETI instruction is executed, the pending Interrupt routine will be processed before returning to the main program.
Operation	Program Counter \leftarrow Stack $EMI \leftarrow 1$
Affected flag(s)	None
RL [m]	Rotate Data Memory left
Description	The contents of the specified Data Memory are rotated left by 1 bit with bit 7 rotated into bit 0.
Operation	$[m].(i+1) \leftarrow [m].i; (i = 0\sim 6)$ $[m].0 \leftarrow [m].7$
Affected flag(s)	None
RLA [m]	Rotate Data Memory left with result in ACC
Description	The contents of the specified Data Memory are rotated left by 1 bit with bit 7 rotated into bit 0. The rotated result is stored in the Accumulator and the contents of the Data Memory remain unchanged.
Operation	$ACC.(i+1) \leftarrow [m].i; (i = 0\sim 6)$ $ACC.0 \leftarrow [m].7$
Affected flag(s)	None

RLC [m]	Rotate Data Memory left through Carry
Description	The contents of the specified Data Memory and the carry flag are rotated left by 1 bit. Bit 7 replaces the Carry bit and the original carry flag is rotated into bit 0.
Operation	$[m].(i+1) \leftarrow [m].i; (i = 0\sim 6)$ $[m].0 \leftarrow C$ $C \leftarrow [m].7$
Affected flag(s)	C
RLCA [m]	Rotate Data Memory left through Carry with result in ACC
Description	Data in the specified Data Memory and the carry flag are rotated left by 1 bit. Bit 7 replaces the Carry bit and the original carry flag is rotated into the bit 0. The rotated result is stored in the Accumulator and the contents of the Data Memory remain unchanged.
Operation	$ACC.(i+1) \leftarrow [m].i; (i = 0\sim 6)$ $ACC.0 \leftarrow C$ $C \leftarrow [m].7$
Affected flag(s)	C
RR [m]	Rotate Data Memory right
Description	The contents of the specified Data Memory are rotated right by 1 bit with bit 0 rotated into bit 7.
Operation	$[m].i \leftarrow [m].(i+1); (i = 0\sim 6)$ $[m].7 \leftarrow [m].0$
Affected flag(s)	None
RRA [m]	Rotate Data Memory right with result in ACC
Description	Data in the specified Data Memory and the carry flag are rotated right by 1 bit with bit 0 rotated into bit 7. The rotated result is stored in the Accumulator and the contents of the Data Memory remain unchanged.
Operation	$ACC.i \leftarrow [m].(i+1); (i = 0\sim 6)$ $ACC.7 \leftarrow [m].0$
Affected flag(s)	None
RRC [m]	Rotate Data Memory right through Carry
Description	The contents of the specified Data Memory and the carry flag are rotated right by 1 bit. Bit 0 replaces the Carry bit and the original carry flag is rotated into bit 7.
Operation	$[m].i \leftarrow [m].(i+1); (i = 0\sim 6)$ $[m].7 \leftarrow C$ $C \leftarrow [m].0$
Affected flag(s)	C
RRCA [m]	Rotate Data Memory right through Carry with result in ACC
Description	Data in the specified Data Memory and the carry flag are rotated right by 1 bit. Bit 0 replaces the Carry bit and the original carry flag is rotated into bit 7. The rotated result is stored in the Accumulator and the contents of the Data Memory remain unchanged.
Operation	$ACC.i \leftarrow [m].(i+1); (i = 0\sim 6)$ $ACC.7 \leftarrow C$ $C \leftarrow [m].0$
Affected flag(s)	C

SBC A,[m]	Subtract Data Memory from ACC with Carry
Description	The contents of the specified Data Memory and the complement of the carry flag are subtracted from the Accumulator. The result is stored in the Accumulator. Note that if the result of subtraction is negative, the C flag will be cleared to 0, otherwise if the result is positive or zero, the C flag will be set to 1.
Operation	$ACC \leftarrow ACC - [m] - \bar{C}$
Affected flag(s)	OV, Z, AC, C
SBCM A,[m]	Subtract Data Memory from ACC with Carry and result in Data Memory
Description	The contents of the specified Data Memory and the complement of the carry flag are subtracted from the Accumulator. The result is stored in the Data Memory. Note that if the result of subtraction is negative, the C flag will be cleared to 0, otherwise if the result is positive or zero, the C flag will be set to 1.
Operation	$[m] \leftarrow ACC - [m] - \bar{C}$
Affected flag(s)	OV, Z, AC, C
SDZ [m]	Skip if decrement Data Memory is 0
Description	The contents of the specified Data Memory are first decremented by 1. If the result is 0 the following instruction is skipped. As this requires the insertion of a dummy instruction while the next instruction is fetched, it is a two cycle instruction. If the result is not 0 the program proceeds with the following instruction.
Operation	$[m] \leftarrow [m] - 1$ Skip if $[m] = 0$
Affected flag(s)	None
SDZA [m]	Skip if decrement Data Memory is zero with result in ACC
Description	The contents of the specified Data Memory are first decremented by 1. If the result is 0, the following instruction is skipped. The result is stored in the Accumulator but the specified Data Memory contents remain unchanged. As this requires the insertion of a dummy instruction while the next instruction is fetched, it is a two cycle instruction. If the result is not 0, the program proceeds with the following instruction.
Operation	$ACC \leftarrow [m] - 1$ Skip if $ACC = 0$
Affected flag(s)	None
SET [m]	Set Data Memory
Description	Each bit of the specified Data Memory is set to 1.
Operation	$[m] \leftarrow FFH$
Affected flag(s)	None
SET [m].i	Set bit of Data Memory
Description	Bit i of the specified Data Memory is set to 1.
Operation	$[m].i \leftarrow 1$
Affected flag(s)	None

SIZ [m]	Skip if increment Data Memory is 0
Description	The contents of the specified Data Memory are first incremented by 1. If the result is 0, the following instruction is skipped. As this requires the insertion of a dummy instruction while the next instruction is fetched, it is a two cycle instruction. If the result is not 0 the program proceeds with the following instruction.
Operation	$[m] \leftarrow [m] + 1$ Skip if $[m] = 0$
Affected flag(s)	None
SIZA [m]	Skip if increment Data Memory is zero with result in ACC
Description	The contents of the specified Data Memory are first incremented by 1. If the result is 0, the following instruction is skipped. The result is stored in the Accumulator but the specified Data Memory contents remain unchanged. As this requires the insertion of a dummy instruction while the next instruction is fetched, it is a two cycle instruction. If the result is not 0 the program proceeds with the following instruction.
Operation	$ACC \leftarrow [m] + 1$ Skip if $ACC = 0$
Affected flag(s)	None
SNZ [m].i	Skip if bit i of Data Memory is not 0
Description	If bit i of the specified Data Memory is not 0, the following instruction is skipped. As this requires the insertion of a dummy instruction while the next instruction is fetched, it is a two cycle instruction. If the result is 0 the program proceeds with the following instruction.
Operation	Skip if $[m].i \neq 0$
Affected flag(s)	None
SUB A,[m]	Subtract Data Memory from ACC
Description	The specified Data Memory is subtracted from the contents of the Accumulator. The result is stored in the Accumulator. Note that if the result of subtraction is negative, the C flag will be cleared to 0, otherwise if the result is positive or zero, the C flag will be set to 1.
Operation	$ACC \leftarrow ACC - [m]$
Affected flag(s)	OV, Z, AC, C
SUBM A,[m]	Subtract Data Memory from ACC with result in Data Memory
Description	The specified Data Memory is subtracted from the contents of the Accumulator. The result is stored in the Data Memory. Note that if the result of subtraction is negative, the C flag will be cleared to 0, otherwise if the result is positive or zero, the C flag will be set to 1.
Operation	$[m] \leftarrow ACC - [m]$
Affected flag(s)	OV, Z, AC, C
SUB A,x	Subtract immediate data from ACC
Description	The immediate data specified by the code is subtracted from the contents of the Accumulator. The result is stored in the Accumulator. Note that if the result of subtraction is negative, the C flag will be cleared to 0, otherwise if the result is positive or zero, the C flag will be set to 1.
Operation	$ACC \leftarrow ACC - x$
Affected flag(s)	OV, Z, AC, C

SWAP [m]	Swap nibbles of Data Memory
Description	The low-order and high-order nibbles of the specified Data Memory are interchanged.
Operation	$[m].3 \sim [m].0 \leftrightarrow [m].7 \sim [m].4$
Affected flag(s)	None
SWAPA [m]	Swap nibbles of Data Memory with result in ACC
Description	The low-order and high-order nibbles of the specified Data Memory are interchanged. The result is stored in the Accumulator. The contents of the Data Memory remain unchanged.
Operation	$ACC.3 \sim ACC.0 \leftarrow [m].7 \sim [m].4$ $ACC.7 \sim ACC.4 \leftarrow [m].3 \sim [m].0$
Affected flag(s)	None
SZ [m]	Skip if Data Memory is 0
Description	If the contents of the specified Data Memory is 0, the following instruction is skipped. As this requires the insertion of a dummy instruction while the next instruction is fetched, it is a two cycle instruction. If the result is not 0 the program proceeds with the following instruction.
Operation	Skip if $[m] = 0$
Affected flag(s)	None
SZA [m]	Skip if Data Memory is 0 with data movement to ACC
Description	The contents of the specified Data Memory are copied to the Accumulator. If the value is zero, the following instruction is skipped. As this requires the insertion of a dummy instruction while the next instruction is fetched, it is a two cycle instruction. If the result is not 0 the program proceeds with the following instruction.
Operation	$ACC \leftarrow [m]$ Skip if $[m] = 0$
Affected flag(s)	None
SZ [m].i	Skip if bit i of Data Memory is 0
Description	If bit i of the specified Data Memory is 0, the following instruction is skipped. As this requires the insertion of a dummy instruction while the next instruction is fetched, it is a two cycle instruction. If the result is not 0, the program proceeds with the following instruction.
Operation	Skip if $[m].i = 0$
Affected flag(s)	None
TABRDC [m]	Read table (current page) to TBLH and Data Memory
Description	The low byte of the program code (current page) addressed by the table pointer (TBLP) is moved to the specified Data Memory and the high byte moved to TBLH.
Operation	$[m] \leftarrow$ program code (low byte) $TBLH \leftarrow$ program code (high byte)
Affected flag(s)	None

TABRDL [m]	Read table (last page) to TBLH and Data Memory
Description	The low byte of the program code (last page) addressed by the table pointer (TBLP) is moved to the specified Data Memory and the high byte moved to TBLH.
Operation	[m] ← program code (low byte) TBLH ← program code (high byte)
Affected flag(s)	None
XOR A,[m]	Logical XOR Data Memory to ACC
Description	Data in the Accumulator and the specified Data Memory perform a bitwise logical XOR operation. The result is stored in the Accumulator.
Operation	ACC ← ACC "XOR" [m]
Affected flag(s)	Z
XORM A,[m]	Logical XOR ACC to Data Memory
Description	Data in the specified Data Memory and the Accumulator perform a bitwise logical XOR operation. The result is stored in the Data Memory.
Operation	[m] ← ACC "XOR" [m]
Affected flag(s)	Z
XOR A,x	Logical XOR immediate data to ACC
Description	Data in the Accumulator and the specified immediate data perform a bitwise logical XOR operation. The result is stored in the Accumulator.
Operation	ACC ← ACC "XOR" x
Affected flag(s)	Z

Package Information

16-pin DIP (300mil) Outline Dimensions

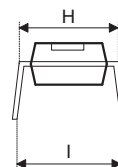
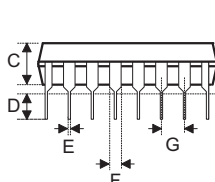
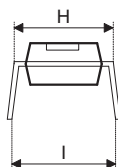
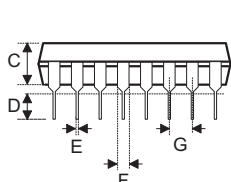
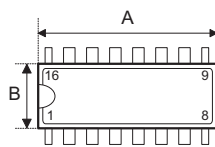
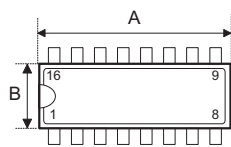

Fig1. Full Lead Packages

Fig2. 1/2 Lead Packages

MS-001d (see fig1)

Symbol	Dimensions in inch		
	Min.	Nom.	Max.
A	0.780	—	0.880
B	0.240	—	0.280
C	0.115	—	0.195
D	0.115	—	0.150
E	0.014	—	0.022
F	0.045	—	0.070
G	—	0.100	—
H	0.300	—	0.325
I	—	—	0.430

Symbol	Dimensions in mm		
	Min.	Nom.	Max.
A	19.81	—	22.35
B	6.10	—	7.11
C	2.92	—	4.95
D	2.92	—	3.81
E	0.36	—	0.56
F	1.14	—	1.78
G	—	2.54	—
H	7.62	—	8.26
I	—	—	10.92

HT66F13/HT66F14/HT66F15
Enhanced A/D Flash Type MCU



MS-001d (see fig2)

Symbol	Dimensions in inch		
	Min.	Nom.	Max.
A	0.735	—	0.775
B	0.240	—	0.280
C	0.115	—	0.195
D	0.115	—	0.150
E	0.014	—	0.022
F	0.045	—	0.070
G	—	0.100	—
H	0.300	—	0.325
I	—	—	0.430

Symbol	Dimensions in mm		
	Min.	Nom.	Max.
A	18.67	—	19.69
B	6.10	—	7.11
C	2.92	—	4.95
D	2.92	—	3.81
E	0.36	—	0.56
F	1.14	—	1.78
G	—	2.54	—
H	7.62	—	8.26
I	—	—	10.92

MO-095a (see fig2)

Symbol	Dimensions in inch		
	Min.	Nom.	Max.
A	0.745	—	0.785
B	0.275	—	0.295
C	0.120	—	0.150
D	0.110	—	0.150
E	0.014	—	0.022
F	0.045	—	0.060
G	—	0.100	—
H	0.300	—	0.325
I	—	—	0.430

Symbol	Dimensions in mm		
	Min.	Nom.	Max.
A	18.92	—	19.94
B	6.99	—	7.49
C	3.05	—	3.81
D	2.79	—	3.81
E	0.36	—	0.56
F	1.14	—	1.52
G	—	2.54	—
H	7.62	—	8.26
I	—	—	10.92

16-pin NSOP (150mil) Outline Dimensions

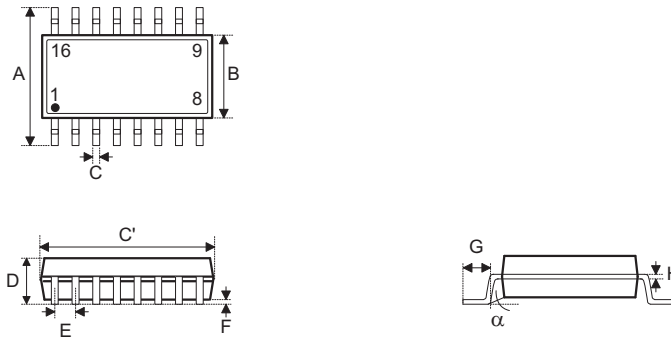

MS-012

Symbol	Dimensions in inch		
	Min.	Nom.	Max.
A	0.228	—	0.244
B	0.150	—	0.157
C	0.012	—	0.020
C'	0.386	—	0.402
D	—	—	0.069
E	—	0.050	—
F	0.004	—	0.010
G	0.016	—	0.050
H	0.007	—	0.010
α	0°	—	8°

Symbol	Dimensions in mm		
	Min.	Nom.	Max.
A	5.79	—	6.20
B	3.81	—	3.99
C	0.30	—	0.51
C'	9.80	—	10.21
D	—	—	1.75
E	—	1.27	—
F	0.10	—	0.25
G	0.41	—	1.27
H	0.18	—	0.25
α	0°	—	8°

16-pin SSOP (150mil) Outline Dimensions

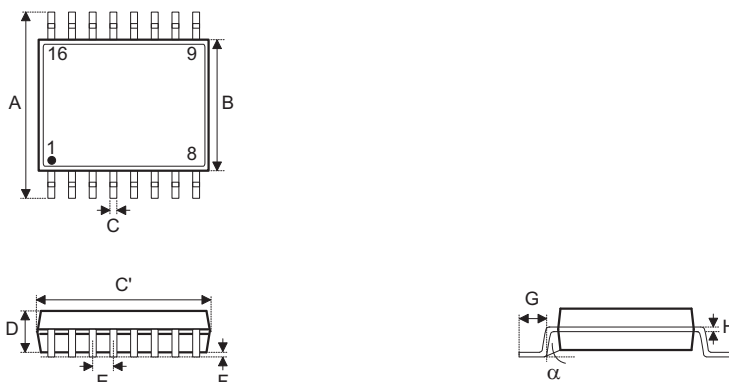

Symbol	Dimensions in inch		
	Min.	Nom.	Max.
A	0.228	—	0.244
B	0.150	—	0.157
C	0.008	—	0.012
C'	0.189	—	0.197
D	0.054	—	0.060
E	—	0.025	—
F	0.004	—	0.010
G	0.022	—	0.028
H	0.007	—	0.010
α	0°	—	8°

Symbol	Dimensions in mm		
	Min.	Nom.	Max.
A	5.79	—	6.20
B	3.81	—	3.99
C	0.20	—	0.30
C'	4.80	—	5.00
D	1.37	—	1.52
E	—	0.64	—
F	0.10	—	0.25
G	0.56	—	0.71
H	0.18	—	0.25
α	0°	—	8°

20-pin DIP (300mil) Outline Dimensions

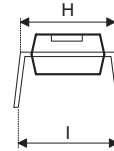
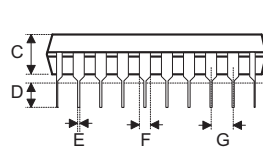
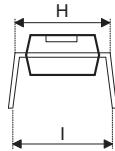
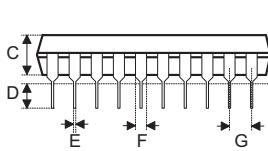
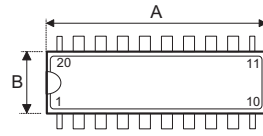
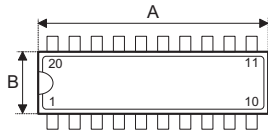

Fig1. Full Lead Packages

Fig2. 1/2 Lead Packages

MS-001d (see fig1)

Symbol	Dimensions in inch		
	Min.	Nom.	Max.
A	0.980	—	1.060
B	0.240	—	0.280
C	0.115	—	0.195
D	0.115	—	0.150
E	0.014	—	0.022
F	0.045	—	0.070
G	—	0.100	—
H	0.300	—	0.325
I	—	0.430	—

Symbol	Dimensions in mm		
	Min.	Nom.	Max.
A	24.89	—	26.92
B	6.10	—	7.11
C	2.92	—	4.95
D	2.92	—	3.81
E	0.36	—	0.56
F	1.14	—	1.78
G	—	2.54	—
H	7.62	—	8.26
I	—	10.92	—

MO-095a (see fig2)

Symbol	Dimensions in inch		
	Min.	Nom.	Max.
A	0.945	—	0.985
B	0.275	—	0.295
C	0.120	—	0.150
D	0.110	—	0.150
E	0.014	—	0.022
F	0.045	—	0.060
G	—	0.100	—
H	0.300	—	0.325
I	—	0.430	—

Symbol	Dimensions in mm		
	Min.	Nom.	Max.
A	24.00	—	25.02
B	6.99	—	7.49
C	3.05	—	3.81
D	2.79	—	3.81
E	0.36	—	0.56
F	1.14	—	1.52
G	—	2.54	—
H	7.62	—	8.26
I	—	10.92	—

HT66F13/HT66F14/HT66F15
Enhanced A/D Flash Type MCU



20-pin SOP (300mil) Outline Dimensions

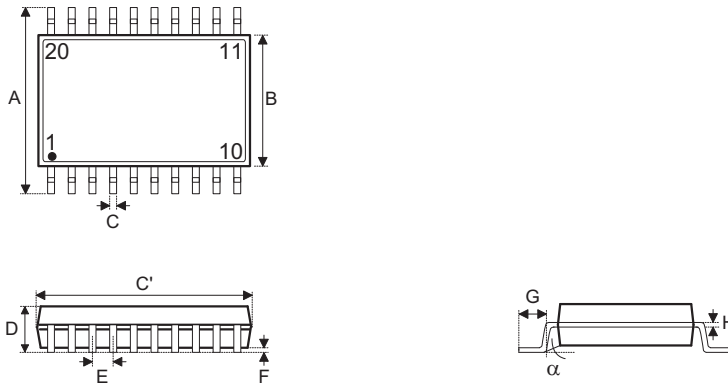

MS-013

Symbol	Dimensions in inch		
	Min.	Nom.	Max.
A	0.393	—	0.419
B	0.256	—	0.300
C	0.012	—	0.020
C'	0.496	—	0.512
D	—	—	0.104
E	—	0.050	—
F	0.004	—	0.012
G	0.016	—	0.050
H	0.008	—	0.013
α	0°	—	8°

Symbol	Dimensions in mm		
	Min.	Nom.	Max.
A	9.98	—	10.64
B	6.50	—	7.62
C	0.30	—	0.51
C'	12.60	—	13.00
D	—	—	2.64
E	—	1.27	—
F	0.10	—	0.30
G	0.41	—	1.27
H	0.20	—	0.33
α	0°	—	8°

20-pin SSOP (150mil) Outline Dimensions

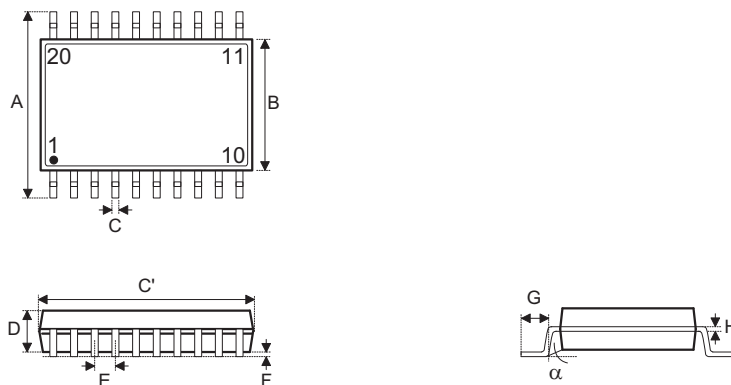

Symbol	Dimensions in inch		
	Min.	Nom.	Max.
A	0.228	—	0.244
B	0.150	—	0.158
C	0.008	—	0.012
C'	0.335	—	0.347
D	0.049	—	0.065
E	—	0.025	—
F	0.004	—	0.010
G	0.015	—	0.050
H	0.007	—	0.010
α	0°	—	8°

Symbol	Dimensions in mm		
	Min.	Nom.	Max.
A	5.79	—	6.20
B	3.81	—	4.01
C	0.20	—	0.30
C'	8.51	—	8.81
D	1.24	—	1.65
E	—	0.64	—
F	0.10	—	0.25
G	0.38	—	1.27
H	0.18	—	0.25
α	0°	—	8°

24-pin SKDIP (300mil) Outline Dimensions

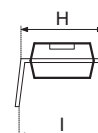
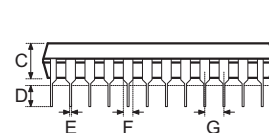
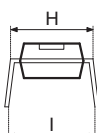
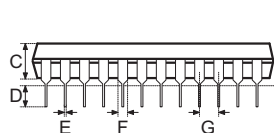
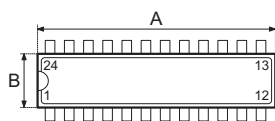

Fig1. Full Lead Packages

Fig2. 1/2 Lead Packages

MS-001d (see fig1)

Symbol	Dimensions in inch		
	Min.	Nom.	Max.
A	1.230	—	1.280
B	0.240	—	0.280
C	0.115	—	0.195
D	0.115	—	0.150
E	0.014	—	0.022
F	0.045	—	0.070
G	—	0.100	—
H	0.300	—	0.325
I	—	0.430	—

Symbol	Dimensions in mm		
	Min.	Nom.	Max.
A	31.24	—	32.51
B	6.10	—	7.11
C	2.92	—	4.95
D	2.92	—	3.81
E	0.36	—	0.56
F	1.14	—	1.78
G	—	2.54	—
H	7.62	—	8.26
I	—	10.92	—

MS-001d (see fig2)

Symbol	Dimensions in inch		
	Min.	Nom.	Max.
A	1.160	—	1.195
B	0.240	—	0.280
C	0.115	—	0.195
D	0.115	—	0.150
E	0.014	—	0.022
F	0.045	—	0.070
G	—	0.100	—
H	0.300	—	0.325
I	—	0.430	—

Symbol	Dimensions in mm		
	Min.	Nom.	Max.
A	29.46	—	30.35
B	6.10	—	7.11
C	2.92	—	4.95
D	2.92	—	3.81
E	0.36	—	0.56
F	1.14	—	1.78
G	—	2.54	—
H	7.62	—	8.26
I	—	10.92	—

HT66F13/HT66F14/HT66F15
Enhanced A/D Flash Type MCU



MO-095a (see fig2)

Symbol	Dimensions in inch		
	Min.	Nom.	Max.
A	1.145	—	1.185
B	0.275	—	0.295
C	0.120	—	0.150
D	0.110	—	0.150
E	0.014	—	0.022
F	0.045	—	0.060
G	—	0.100	—
H	0.300	—	0.325
I	—	0.430	—

Symbol	Dimensions in mm		
	Min.	Nom.	Max.
A	29.08	—	30.10
B	6.99	—	7.49
C	3.05	—	3.81
D	2.79	—	3.81
E	0.36	—	0.56
F	1.14	—	1.52
G	—	2.54	—
H	7.62	—	8.26
I	—	10.92	—

24-pin SOP (300mil) Outline Dimensions

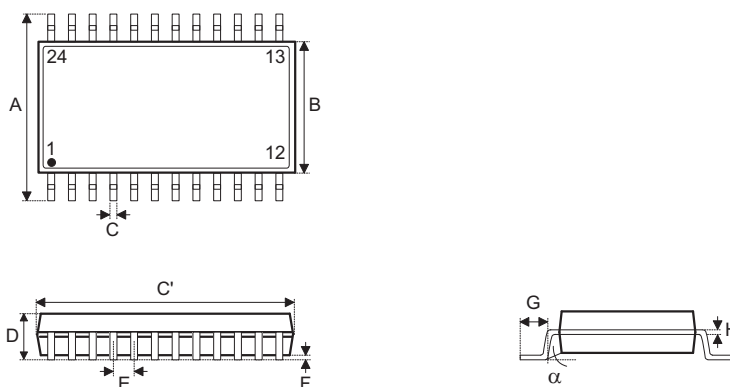

MS-013

Symbol	Dimensions in inch		
	Min.	Nom.	Max.
A	0.393	—	0.419
B	0.256	—	0.300
C	0.012	—	0.020
C'	0.598	—	0.613
D	—	—	0.104
E	—	0.050	—
F	0.004	—	0.012
G	0.016	—	0.050
H	0.008	—	0.013
α	0°	—	8°

Symbol	Dimensions in mm		
	Min.	Nom.	Max.
A	9.98	—	10.64
B	6.50	—	7.62
C	0.30	—	0.51
C'	15.19	—	15.57
D	—	—	2.64
E	—	1.27	—
F	0.10	—	0.30
G	0.41	—	1.27
H	0.20	—	0.33
α	0°	—	8°

HT66F13/HT66F14/HT66F15
Enhanced A/D Flash Type MCU



24-pin SSOP (150mil) Outline Dimensions

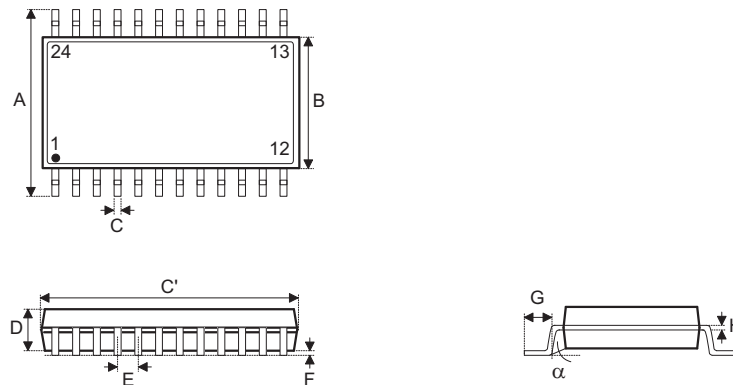

Symbol	Dimensions in inch		
	Min.	Nom.	Max.
A	0.228	—	0.244
B	0.150	—	0.157
C	0.008	—	0.012
C'	0.335	—	0.346
D	0.054	—	0.060
E	—	0.025	—
F	0.004	—	0.010
G	0.022	—	0.028
H	0.007	—	0.010
α	0°	—	8°

Symbol	Dimensions in mm		
	Min.	Nom.	Max.
A	5.79	—	6.20
B	3.81	—	3.99
C	0.20	—	0.30
C'	8.51	—	8.79
D	1.37	—	1.52
E	—	0.64	—
F	0.10	—	0.25
G	0.56	—	0.71
H	0.18	—	0.25
α	0°	—	8°

28-pin SKDIP (300mil) Outline Dimensions

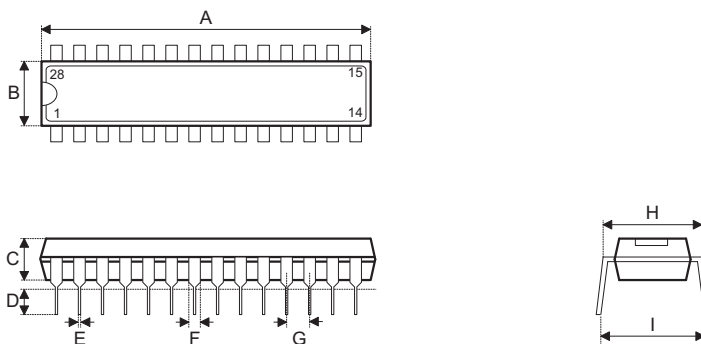

Symbol	Dimensions in inch		
	Min.	Nom.	Max.
A	1.375	—	1.395
B	0.278	—	0.298
C	0.125	—	0.135
D	0.125	—	0.145
E	0.016	—	0.020
F	0.050	—	0.070
G	—	0.100	—
H	0.295	—	0.315
I	—	0.375	—

Symbol	Dimensions in mm		
	Min.	Nom.	Max.
A	34.93	—	35.43
B	7.06	—	7.57
C	3.18	—	3.43
D	3.18	—	3.68
E	0.41	—	0.51
F	1.27	—	1.78
G	—	2.54	—
H	7.49	—	8.00
I	—	9.53	—

28-pin SOP (300mil) Outline Dimensions

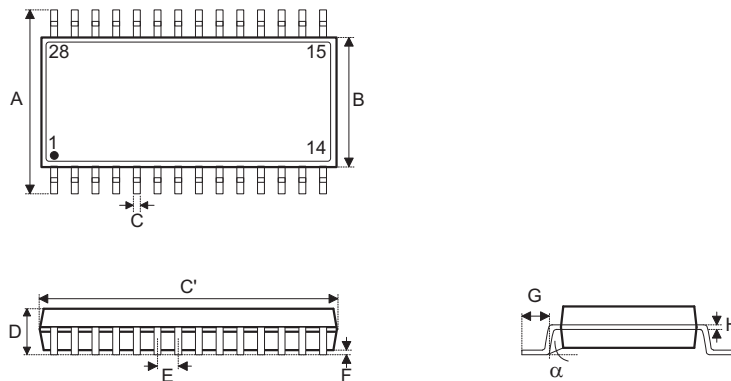

MS-013

Symbol	Dimensions in inch		
	Min.	Nom.	Max.
A	0.393	—	0.419
B	0.256	—	0.300
C	0.012	—	0.020
C'	0.697	—	0.713
D	—	—	0.104
E	—	0.050	—
F	0.004	—	0.012
G	0.016	—	0.050
H	0.008	—	0.013
α	0°	—	8°

Symbol	Dimensions in mm		
	Min.	Nom.	Max.
A	9.98	—	10.64
B	6.50	—	7.62
C	0.30	—	0.51
C'	17.70	—	18.11
D	—	—	2.64
E	—	1.27	—
F	0.10	—	0.30
G	0.41	—	1.27
H	0.20	—	0.33
α	0°	—	8°

28-pin SSOP (150mil) Outline Dimensions

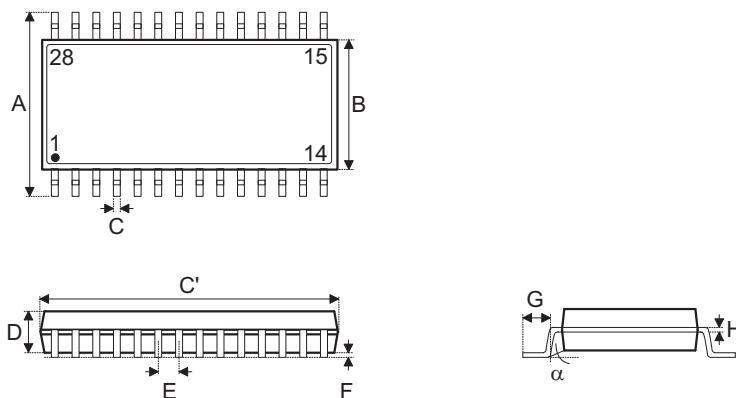

Symbol	Dimensions in inch		
	Min.	Nom.	Max.
A	0.228	—	0.244
B	0.150	—	0.157
C	0.008	—	0.012
C'	0.386	—	0.394
D	0.054	—	0.060
E	—	0.025	—
F	0.004	—	0.010
G	0.022	—	0.028
H	0.007	—	0.010
α	0°	—	8°

Symbol	Dimensions in mm		
	Min.	Nom.	Max.
A	5.79	—	6.20
B	3.81	—	3.99
C	0.20	—	0.30
C'	9.80	—	10.01
D	1.37	—	1.52
E	—	0.64	—
F	0.10	—	0.25
G	0.56	—	0.71
H	0.18	—	0.25
α	0°	—	8°

Reel Dimensions

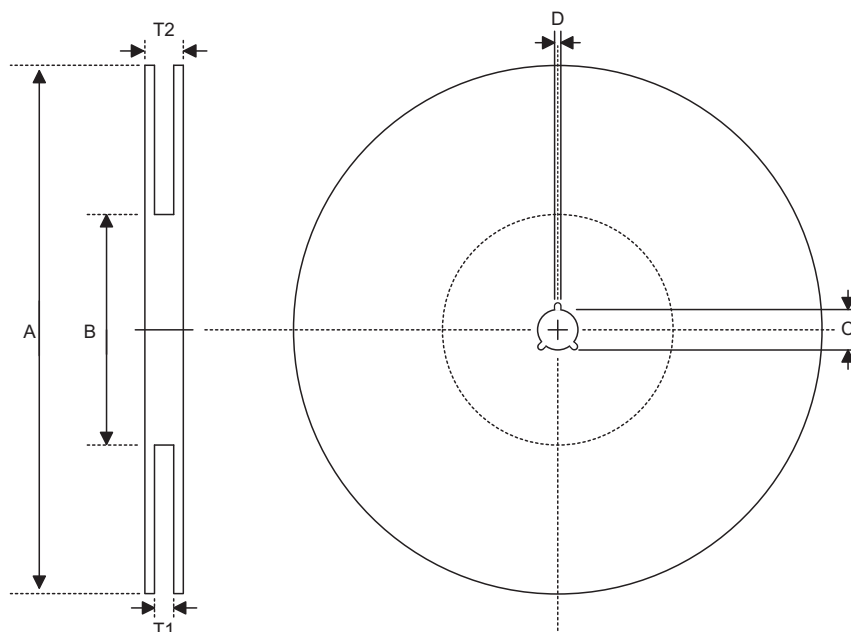

SOP 16N (150mil)

Symbol	Description	Dimensions in mm
A	Reel Outer Diameter	330.0±1.0
B	Reel Inner Diameter	100.0±1.5
C	Spindle Hole Diameter	13.0 ^{+0.5/-0.2}
D	Key Slit Width	2.0±0.5
T1	Space Between Flange	16.8 ^{+0.3/-0.2}
T2	Reel Thickness	22.2±0.2

SOP 20W, SOP 24W, SOP 28W (300mil)

Symbol	Description	Dimensions in mm
A	Reel Outer Diameter	330.0±1.0
B	Reel Inner Diameter	100.0±1.5
C	Spindle Hole Diameter	13.0 ^{+0.5/-0.2}
D	Key Slit Width	2.0±0.5
T1	Space Between Flange	24.8 ^{+0.3/-0.2}
T2	Reel Thickness	30.2±0.2

SSOP 16S

Symbol	Description	Dimensions in mm
A	Reel Outer Diameter	330.0±1.0
B	Reel Inner Diameter	100.0±1.5
C	Spindle Hole Diameter	13.0 ^{+0.5/-0.2}
D	Key Slit Width	2.0±0.5
T1	Space Between Flange	12.8 ^{+0.3/-0.2}
T2	Reel Thickness	18.2±0.2

SSOP 20S (150mil), SSOP 24S (150mil), SSOP 28S (150mil)

Symbol	Description	Dimensions in mm
A	Reel Outer Diameter	330.0±1.0
B	Reel Inner Diameter	100.0±1.5
C	Spindle Hole Diameter	13.0 ^{+0.5/-0.2}
D	Key Slit Width	2.0±0.5
T1	Space Between Flange	16.8 ^{+0.3/-0.2}
T2	Reel Thickness	22.2±0.2

SSOP 48W

Symbol	Description	Dimensions in mm
A	Reel Outer Diameter	330.0±1.0
B	Reel Inner Diameter	100.0±0.1
C	Spindle Hole Diameter	13.0 ^{+0.5/-0.2}
D	Key Slit Width	2.0±0.5
T1	Space Between Flange	32.2 ^{+0.3/-0.2}
T2	Reel Thickness	38.2±0.2

Carrier Tape Dimensions

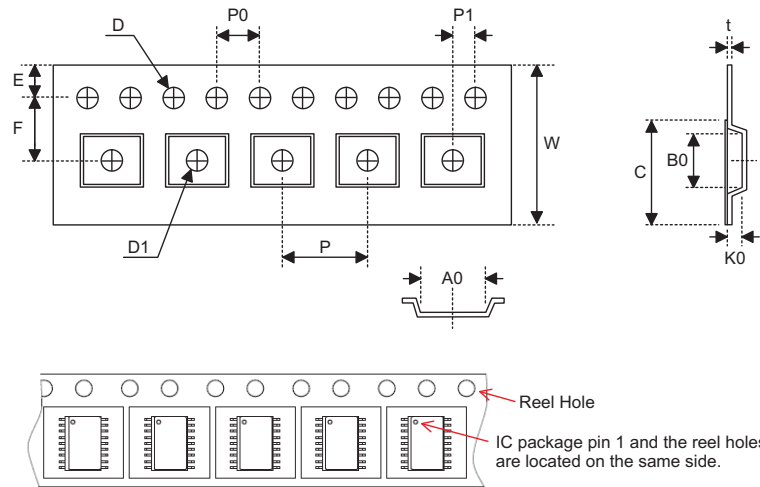

SOP 16N (150mil)

Symbol	Description	Dimensions in mm
W	Carrier Tape Width	16.0±0.3
P	Cavity Pitch	8.0±0.1
E	Perforation Position	1.75±0.1
F	Cavity to Perforation (Width Direction)	7.5±0.1
D	Perforation Diameter	1.55 ^{+0.10/-0.00}
D1	Cavity Hole Diameter	1.50 ^{+0.25/-0.00}
P0	Perforation Pitch	4.0±0.1
P1	Cavity to Perforation (Length Direction)	2.0±0.1
A0	Cavity Length	6.5±0.1
B0	Cavity Width	10.3±0.1
K0	Cavity Depth	2.1±0.1
t	Carrier Tape Thickness	0.30±0.05
C	Cover Tape Width	13.3±0.1

SOP 20W

Symbol	Description	Dimensions in mm
W	Carrier Tape Width	24.0 ^{+0.3/-0.1}
P	Cavity Pitch	12.0±0.1
E	Perforation Position	1.75±0.10
F	Cavity to Perforation (Width Direction)	11.5±0.1
D	Perforation Diameter	1.5 ^{+0.1/-0.0}
D1	Cavity Hole Diameter	1.50 ^{+0.25/-0.00}
P0	Perforation Pitch	4.0±0.1
P1	Cavity to Perforation (Length Direction)	2.0±0.1
A0	Cavity Length	10.8±0.1
B0	Cavity Width	13.3±0.1
K0	Cavity Depth	3.2±0.1
t	Carrier Tape Thickness	0.30±0.05
C	Cover Tape Width	21.3±0.1

SOP 24W

Symbol	Description	Dimensions in mm
W	Carrier Tape Width	24.0±0.3
P	Cavity Pitch	12.0±0.1
E	Perforation Position	1.75±0.1
F	Cavity to Perforation (Width Direction)	11.5±0.1
D	Perforation Diameter	1.55 ^{+0.10/-0.00}
D1	Cavity Hole Diameter	1.50 ^{+0.25/-0.00}
P0	Perforation Pitch	4.0±0.1
P1	Cavity to Perforation (Length Direction)	2.0±0.1
A0	Cavity Length	10.9±0.1
B0	Cavity Width	15.9±0.1
K0	Cavity Depth	3.1±0.1
t	Carrier Tape Thickness	0.35±0.05
C	Cover Tape Width	21.3±0.1

HT66F13/HT66F14/HT66F15
Enhanced A/D Flash Type MCU



SOP 28W (300mil)

Symbol	Description	Dimensions in mm
W	Carrier Tape Width	24.0±0.3
P	Cavity Pitch	12.0±0.1
E	Perforation Position	1.75±0.10
F	Cavity to Perforation (Width Direction)	11.5±0.1
D	Perforation Diameter	1.5 ^{+0.1/-0.0}
D1	Cavity Hole Diameter	1.50 ^{+0.25/-0.00}
P0	Perforation Pitch	4.0±0.1
P1	Cavity to Perforation (Length Direction)	2.0±0.1
A0	Cavity Length	10.85±0.10
B0	Cavity Width	18.34±0.10
K0	Cavity Depth	2.97±0.10
t	Carrier Tape Thickness	0.35±0.01
C	Cover Tape Width	21.3±0.1

SSOP 16S

Symbol	Description	Dimensions in mm
W	Carrier Tape Width	12.0 ^{+0.3/-0.1}
P	Cavity Pitch	8.0±0.1
E	Perforation Position	1.75±0.10
F	Cavity to Perforation (Width Direction)	5.5±0.1
D	Perforation Diameter	1.55±0.10
D1	Cavity Hole Diameter	1.50 ^{+0.25/-0.00}
P0	Perforation Pitch	4.0±0.1
P1	Cavity to Perforation (Length Direction)	2.0±0.1
A0	Cavity Length	6.4±0.1
B0	Cavity Width	5.2±0.1
K0	Cavity Depth	2.1±0.1
t	Carrier Tape Thickness	0.30±0.05
C	Cover Tape Width	9.3±0.1

SSOP 20S (150mil)

Symbol	Description	Dimensions in mm
W	Carrier Tape Width	16.0 ^{+0.3/-0.1}
P	Cavity Pitch	8.0±0.1
E	Perforation Position	1.75±0.10
F	Cavity to Perforation (Width Direction)	7.5±0.1
D	Perforation Diameter	1.5 ^{+0.1/-0.0}
D1	Cavity Hole Diameter	1.50 ^{+0.25/-0.00}
P0	Perforation Pitch	4.0±0.1
P1	Cavity to Perforation (Length Direction)	2.0±0.1
A0	Cavity Length	6.5±0.1
B0	Cavity Width	9.0±0.1
K0	Cavity Depth	2.3±0.1
t	Carrier Tape Thickness	0.30±0.05
C	Cover Tape Width	13.3±0.1

SSOP 24S (150mil)

Symbol	Description	Dimensions in mm
W	Carrier Tape Width	16.0 ^{+0.3/-0.1}
P	Cavity Pitch	8.0±0.1
E	Perforation Position	1.75±0.10
F	Cavity to Perforation (Width Direction)	7.5±0.1
D	Perforation Diameter	1.5 ^{+0.1/-0.0}
D1	Cavity Hole Diameter	1.50 ^{+0.25/-0.00}
P0	Perforation Pitch	4.0±0.1
P1	Cavity to Perforation (Length Direction)	2.0±0.1
A0	Cavity Length	6.5±0.1
B0	Cavity Width	9.5±0.1
K0	Cavity Depth	2.1±0.1
t	Carrier Tape Thickness	0.30±0.05
C	Cover Tape Width	13.3±0.1

HT66F13/HT66F14/HT66F15
Enhanced A/D Flash Type MCU



SSOP 28S (150mil)

Symbol	Description	Dimensions in mm
W	Carrier Tape Width	16.0±0.3
P	Cavity Pitch	8.0±0.1
E	Perforation Position	1.75±0.1
F	Cavity to Perforation (Width Direction)	7.5±0.1
D	Perforation Diameter	1.55 ^{+0.10/-0.00}
D1	Cavity Hole Diameter	1.50 ^{+0.25/-0.00}
P0	Perforation Pitch	4.0±0.1
P1	Cavity to Perforation (Length Direction)	2.0±0.1
A0	Cavity Length	6.5±0.1
B0	Cavity Width	10.3±0.1
K0	Cavity Depth	2.1±0.1
t	Carrier Tape Thickness	0.30±0.05
C	Cover Tape Width	13.3±0.1

Holtek Semiconductor Inc. (Headquarters)

No.3, Creation Rd. II, Science Park, Hsinchu, Taiwan
Tel: 886-3-563-1999
Fax: 886-3-563-1189
<http://www.holtek.com.tw>

Holtek Semiconductor Inc. (Taipei Sales Office)

4F-2, No. 3-2, YuanQu St., Nankang Software Park, Taipei 115, Taiwan
Tel: 886-2-2655-7070
Fax: 886-2-2655-7373
Fax: 886-2-2655-7383 (International sales hotline)

Holtek Semiconductor (China) Inc. (Dongguan Sales Office)

Building No. 10, Xinzhu Court, (No. 1 Headquarters), 4 Cuizhu Road, Songshan Lake, Dongguan, China 523808
Tel: 86-769-2626-1300
Fax: 86-769-2626-1311

Holtek Semiconductor (USA), Inc. (North America Sales Office)

46729 Fremont Blvd., Fremont, CA 94538, USA
Tel: 1-510-252-9880
Fax: 1-510-252-9885
<http://www.holtek.com>

Copyright © 2011 by HOLTEK SEMICONDUCTOR INC.

The information appearing in this Data Sheet is believed to be accurate at the time of publication. However, Holtek assumes no responsibility arising from the use of the specifications described. The applications mentioned herein are used solely for the purpose of illustration and Holtek makes no warranty or representation that such applications will be suitable without further modification, nor recommends the use of its products for application that may present a risk to human life due to malfunction or otherwise. Holtek's products are not authorized for use as critical components in life support devices or systems. Holtek reserves the right to alter its products without prior notification. For the most up-to-date information, please visit our web site at <http://www.holtek.com.tw>.