



Enhanced Flash Type 8-Bit MCU with EEPROM

**HT66F016/HT66F017
HT68F016/HT68F017
HT66F016R/HT66F017R
HT68F016R/HT68F017R**

Revision: 1.10 Date: September 26, 2012

www.holtek.com

Table of Contents

General Description	7
Features	7
CPU Features	7
Peripheral Features	7
Technical Document	7
Selection Table	8
Block Diagram	8
Pin Assignment	9
Pin Description	10
HT66F016/HT66F017	10
HT68F016/HT68F017	11
Absolute Maximum Ratings	11
D.C. Characteristics	12
A.C. Characteristics	14
A/D Converter Characteristics	15
Comparator Electrical Characteristics	15
Power-on Reset Characteristics	16
Bandgap Reference (V_{bg}) Characteristic Curve	16
System Architecture	17
Clocking and Pipelining	17
Program Counter	18
Stack	18
Arithmetic and Logic Unit – ALU	18
Flash Program Memory	19
Structure	19
Special Vectors	19
Look-up Table	19
Table Program Example	19
In Circuit Programming	20
RAM Data Memory	21
Structure	21

Special Function Register Description	23
Indirect Addressing Registers – IAR0, IAR1.....	23
Memory Pointers – MP0, MP1	23
Bank Pointer – BP	24
Accumulator – ACC	24
Program Counter Low Register – PCL.....	24
Look-up Table Registers – TBLP, TBHP, TBLH.....	24
Status Register – STATUS	25
EEPROM Data Memory	26
EEPROM Data Memory Structure	26
EEPROM Registers.....	26
Reading Data from the EEPROM	28
Writing Data to the EEPROM	28
Write Protection	28
EEPROM Interrupt	28
Programming Considerations	28
Oscillator.....	30
Oscillator Overview.....	30
System Clock Configurations.....	30
External Crystal/Ceramic Oscillator – HXT	31
Internal RC Oscillator – HIRC	31
Internal 32kHz Oscillator – LIRC.....	31
Supplementary Oscillators.....	31
Operating Modes and System Clocks	32
System Clocks.....	32
System Operation Modes	33
Control Register	34
Fast Wake-up	35
Operating Mode Switching and Wake-up.....	35
NORMAL Mode to SLOW Mode Switching.....	36
SLOW Mode to NORMAL Mode Switching.....	37
Entering the SLEEP0 Mode.....	37
Entering the SLEEP1 Mode.....	38
Entering the IDLE0 Mode	38
Entering the IDLE1 Mode	38
Standby Current Considerations.....	38
Wake-up.....	39
Programming Considerations	39
Watchdog Timer	40
Watchdog Timer Clock Source	40
Watchdog Timer Control Register.....	40
Watchdog Timer Operation.....	40
Watchdog Timer Enable/Disable Control	40

Reset and Initialisation	42
Reset Functions	42
Reset Initial Conditions	43
Input/Output Ports.....	46
Pull-High Resistors	46
Port A Wake-up	47
I/O Port Control Register	47
Pin-remapping Functions.....	48
Pin-remapping Registers	48
I/O Pin Structures	48
Programming Considerations	48
Timer Modules – TM.....	50
Introduction	50
TM Operation	50
TM Clock Source	50
TM Interrupts.....	51
TM External Pins	51
Programming Considerations	52
Compact Type TM – CTM.....	53
Compact TM Operation	53
Compact Type TM Register Description	54
CTM Register List.....	54
Compact Type TM Operating Modes	58
Compare Match Output Mode	58
Timer/Counter Mode.....	60
PWM Output Mode.....	60
Standard Type TM – STM.....	62
Standard TM Operation	62
Standard Type TM Register Description	62
STM Register List.....	63
Standard Type TM Operating Modes	67
Compare Output Mode	67
Timer/Counter Mode.....	69
PWM Output Mode	69
Single Pulse Mode	71
Capture Input Mode.....	72
Analog to Digital Converter.....	73
A/D Overview	73
A/D Converter Register Description	73
A/D Converter Data Registers ADRL, ADRH.....	73
A/D Converter Control Registers – ADCR0, ADCR1, ACERL.....	73
A/D Operation.....	77
A/D Input Pins	78

Summary of A/D Conversion Steps	78
Programming Considerations	79
A/D Transfer Function.....	79
A/D Programming Example	79
Comparators	82
Comparator Operation.....	82
Comparator Interrupt	82
Programming Considerations	82
Interrupts.....	84
Interrupt Registers	84
Interrupt Operation	88
External Interrupt.....	90
Comparator Interrupt	90
Multi-function Interrupt.....	90
A/D Converter Interrupt	90
Time Base Interrupts	90
EEPROM Interrupt	92
LVD Interrupt	92
TM Interrupts.....	92
Interrupt Wake-up Function	92
Programming Considerations	93
Low Voltage Detector – LVD	94
LVD Register	94
LVD Operation.....	95
Configuration Options	96
Application Circuits	96
Instruction Set	97
Introduction	97
Instruction Timing	97
Moving and Transferring Data	97
Arithmetic Operations	97
Logical and Rotate Operations	97
Branches and Control Transfer.....	97
Bit Operations.....	98
Table Read Operations.....	98
Other Operations.....	98
Instruction Set Summary	98
Instruction Definition	100

Package Information	110
16-pin DIP (300mil) Outline Dimensions	110
16-pin NSOP (150mil) Outline Dimensions	112
16-pin SSOP (150mil) Outline Dimensions	113
Product Tape and Reel Specifications.....	114

Technical Document

- [Application Note](#)
 - [HA0075E MCU Reset and Oscillator Circuits Application Note](#)

Features

CPU Features

- Operating Voltage:
 - $f_{SYS}= 8\text{MHz}$: 2.2V~5.5V
 - $f_{SYS}= 12\text{MHz}$: 2.7V~5.5V
 - $f_{SYS}= 20\text{MHz}$: 4.5V~5.5V
- Up to 0.2 μs instruction cycle with 20MHz system clock at $V_{DD}=5\text{V}$
- Power down and wake-up functions to reduce power consumption
- Three oscillators
 - External crystal -- HXT
 - Internal RC --HIRC
 - Internal 32kHz RC -- LIRC
- Multi-mode operation: NORMAL, SLOW, IDLE and SLEEP
- Fully integrated internal 8MHz oscillator requires no external components
- All instructions executed in one or two instruction cycles
- Table read instructions
- 63 powerful instructions
- 8 subroutine nesting levels
- Bit manipulation instruction

Peripheral Features

- Flash Program Memory: up to 2K \times 16
- RAM Data Memory: up to 128 \times 8
- EEPROM Memory: 64 \times 8
- Watchdog Timer function
- 14 bidirectional I/O lines
- Two external interrupt lines shared with I/O pins
- Multiple Timer Module for time measure, input capture, compare match output, PWM output or single pulse output functions
- Comparator function
- Dual Time-Base functions for generation of fixed time interrupt signals
- Low voltage reset function
- Low voltage detect function
- 4-channel 12-bit resolution A/D converter
- Package types: 16-pin DIP/NSOP/SSOP
- Flash program memory can be re-programmed up to 100,000 times
- Flash program memory data retention > 10 years
- EEPROM data memory can be re-programmed up to 1,000,000 times
- EEPROM data memory data retention > 10 years

General Description

The devices are Flash Memory type 8-bit high performance RISC architecture microcontrollers. Offering users the convenience of Flash Memory multi-programming features, these devices also include a wide range of functions and features. Other memory includes an area of RAM Data Memory as well as an area of EEPROM memory for storage of non-volatile data such as serial numbers, calibration data etc.

Analog features include a multi-channel 12-bit A/D converter and a comparator functions. Multiple and extremely flexible Timer Modules provide timing, pulse generation and PWM generation functions. Protective features such as an internal Watchdog Timer, Low Voltage Reset and Low Voltage Detector coupled with excellent noise immunity and ESD protection ensure that reliable operation is maintained in hostile electrical environments.

A full choice of HXT, HIRC and LIRC oscillator functions are provided including a fully integrated system oscillator which requires no external components for its implementation. The ability to operate and switch dynamically between a range of operating modes using different clock sources gives users the ability to optimise microcontroller operation and minimize power consumption.

The inclusion of flexible I/O programming features, Time-Base functions along with many other features ensure that the devices will find excellent use in applications such as electronic metering, environmental monitoring, handheld instruments, household appliances, electronically controlled tools, motor driving in addition to many others.

Selection Table

Most features are common to all devices. The main feature distinguishing them is the A/D Converter only. The following table summarises the main features of each device.

Device	Program Memory	Data Memory	Data EEPROM	I/O	A/D	16-bit Timer Module	Time Base	Comparator	Stack	Package
HT68F016	1Kx16	64x8	64x8	14	—	STMx1	2	1	4	16DIP/NSOP/SSOP
HT68F017	2Kx16	128x8	64x8	14	—	CTMx1 STMx1	2	1	8	16DIP/NSOP/SSOP
HT66F016	1Kx16	64x8	64x8	14	12-bitx4	STMx1	2	1	4	16DIP/NSOP/SSOP
HT66F017	2Kx16	128x8	64x8	14	12-bitx4	CTMx1 STMx1	2	1	8	16DIP/NSOP/SSOP

Note: The external reset pin is provided in HT66F016R/HT66F017R/HT68F016R/HT68F017R

Block Diagram

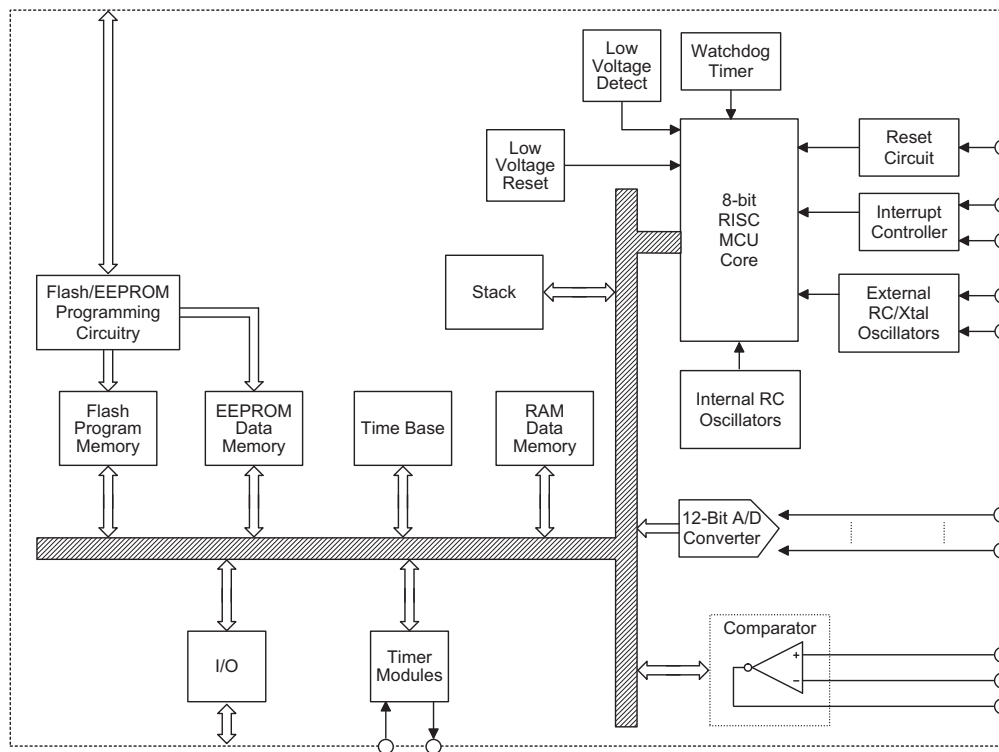

Pin Assignment

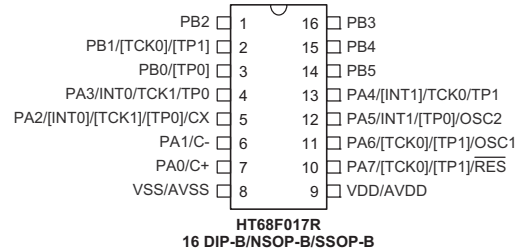
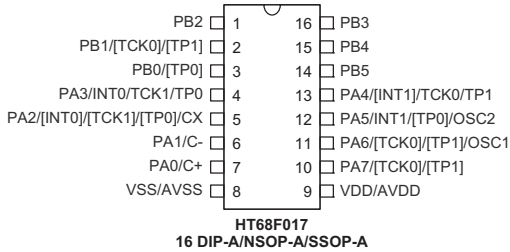
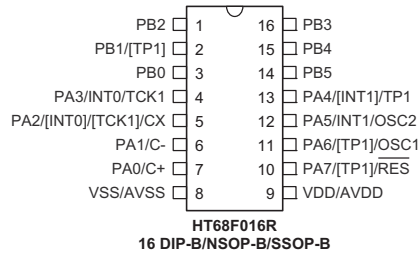
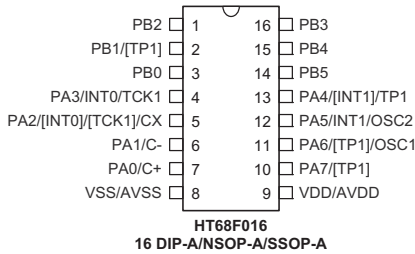
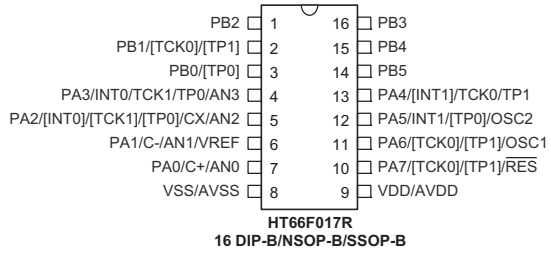
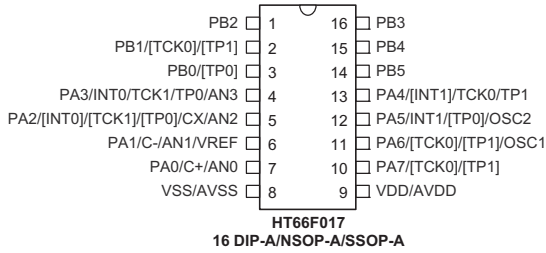
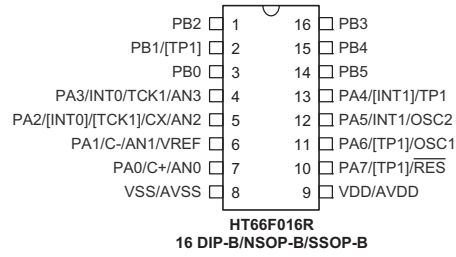
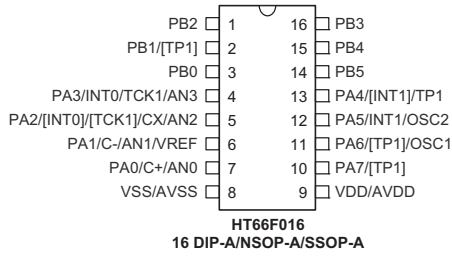

- Note:
1. Bracketed pin names indicate non-default pinout remapping locations.
 2. If the pin-shared pin functions have multiple outputs simultaneously, its pin names at the right side of the "/" sign can be used for higher priority.
 3. VDD&AVDD means the VDD and AVDD are the double bonding.

Pin Description

With the exception of the power pins, all pins on these devices can be referenced by their Port name, e.g. PA.0, PA.1 etc, which refer to the digital I/O function of the pins. However these Port pins are also shared with other function such as the Analog to Digital Converter, Timer Module pins etc. The function of each pin is listed in the following table, however the details behind how each pin is configured is contained in other sections of the datasheet.

The following tables only include the pins which are directly related to the MCU. The pin descriptions of the additional peripheral functions are located at the end of the datasheet along with the relevant peripheral function functional description.

HT66F016, HT68F016

Pin Name	Function	OP	I/T	O/T	Pin-Shared Mapping
PA0~PA7	Port A	PAWU PAPU	ST	CMOS	—
PB0~PB5	Port B	PBPU	ST	CMOS	—
AN0~AN3	A/D converter input	ACERL	AN	—	PA0~PA3
VREF	A/D converter reference input	ADCR1	AN	—	PA1
C-	Comparator input	CPC	AN	—	PA1
C+	Comparator input		AN	—	PA0
CX	Comparator output		—	CMOS	PA2
TCK1	TM1 input	PRM	ST	—	PA2 or PA3
TP1	TM1 I/O	PRM TMPC	ST	CMOS	PA4, PA6, PA7 or PB1
INT0	External Interrupt 0	INTC0 INTEG	ST	—	PA3 or PA2
INT1	External Interrupt 1	INTC2 INTEG	ST	—	PA5 or PA4
OSC1	HXT pin	CO	HXT	—	PA6
OSC2	HXT pin	CO	—	HXT	PA5
RES	Reset input	CO	ST	—	PA7
VDD	Power supply	—	PWR	—	—
VSS	Ground	—	PWR	—	—

Note: I/T: Input type; O/T: Output type

OP: Optional by configuration option (CO) or register option

PWR: Power; CO: Configuration option; ST: Schmitt Trigger input

CMOS: CMOS output

AN: Analog input pin

HXT: High frequency crystal oscillator

HT68F016 doesn't have AN0~AN3, VREF pin.

HT68F017, HT68F017

Pin Name	Function	OP	I/T	O/T	Pin-Shared Mapping
PA0~PA7	Port A	PAWU PAPU	ST	CMOS	—
PB0~PB5	Port B	PBPU	ST	CMOS	—
AN0~AN3	A/D converter input	ACERL	AN	—	PA0~PA3
VREF	A/D converter reference input	ADCR1	AN	—	PA1
C-	Comparator input	CPC	AN	—	PA1
C+	Comparator input		AN	—	PA0
CX	Comparator output		—	CMOS	PA2
TCK0	TM0 input	PRM	ST	—	PA4, PA6, PA7 or PB1
TCK1	TM1 input	PRM	ST	—	PA2 or PA3
TP0	TM0 I/O	PRM TMPC	ST	CMOS	PA2, PA3, PA5 or PB0
TP1	TM1 I/O	PRM TMPC	ST	CMOS	PA4, PA6, PA7 or PB1
INT0	External Interrupt	INTC0 INTEG	ST	—	PA3 or PA2
INT1	External Interrupt	INTC2 INTEG	ST	—	PA5 or PA4
OSC1	HXT pin	CO	HXT	—	PA6
OSC2	HXT pin	CO	—	HXT	PA5
RES	Reset input	CO	ST	—	PA7
VDD	Power supply *	—	PWR	—	—
AVDD	A/D converter power supply *	—	PWR	—	—
VSS	Ground **	—	PWR	—	—
AVSS	A/D converter ground **	—	PWR	—	—

Note: I/T: Input type; O/T: Output type

OP: Optional by configuration option (CO) or register option

PWR: Power; CO: Configuration option; ST: Schmitt Trigger input

CMOS: CMOS output

HXT: High frequency crystal oscillator

*: VDD is the device power supply while AVDD is the ADC power supply. The AVDD pin is bonded together internally with VDD.

** : VSS is the device ground pin while AVSS is the ADC ground pin. The AVSS pin is bonded together internally with VSS.

HT68F017 doesn't have AN0~AN3, VREF pin.

Absolute Maximum Ratings

Supply Voltage $V_{SS}-0.3V$ to $V_{SS}+6.0V$

Input Voltage $V_{SS}-0.3V$ to $V_{DD}+0.3V$

I_{OL} Total80mA

Total Power Dissipation500mW

Storage Temperature $-50^{\circ}C$ to $125^{\circ}C$

Operating Temperature $-40^{\circ}C$ to $85^{\circ}C$

I_{OH} Total $-80mA$

Note: These are stress ratings only. Stresses exceeding the range specified under "Absolute Maximum Ratings" may cause substantial damage to the device. Functional operation of this device at other conditions beyond those listed in the specification is not implied and prolonged exposure to extreme conditions may affect device reliability.

D.C. Characteristics

Ta=25°C

Symbol	Parameter	Test Conditions		Min.	Typ.	Max.	Unit
		V _{DD}	Conditions				
V _{DD}	Operating Voltage (HXT, HIRC)	—	f _{SYS} =8MHz	2.2	—	5.5	V
			f _{SYS} =12MHz	2.7	—	5.5	V
			f _{SYS} =20MHz	4.5	—	5.5	V
I _{DD1}	Operating Current (HXT), (f _{SYS} =f _H , f _S =f _{SUB} =f _{LIRC})	3V	No load, f _H =8MHz, ADC off, WDT enable	—	1.0	1.5	mA
		5V	ADC off, WDT enable	—	2.5	4.0	mA
		3V	No load, f _H =12MHz, ADC off, WDT enable	—	1.5	2.5	mA
		5V	ADC off, WDT enable	—	3.5	5.5	mA
		3V	No load, f _H =16MHz, ADC off, WDT enable	—	2.0	3.0	mA
		5V	ADC off, WDT enable	—	4.5	7.0	mA
I _{DD2}	Operating Current (HIRC), (f _{SYS} =f _H , f _S =f _{SUB} =f _{LIRC})	3V	No load, f _H =8MHz, ADC off, WDT enable	—	1.4	2.1	mA
		5V	ADC off, WDT enable	—	2.4	3.6	mA
I _{DD3}	Operating Current (LIRC), (f _{SYS} =f _L =f _{LIRC} , f _S =f _{SUB} =f _{LIRC})	3V	No load, ADC off, WDT enable	—	10	20	μA
		5V	WDT enable	—	30	50	μA
I _{IDLE0}	IDLE0 Mode Standby Current (LIRC on)	3V	No load, ADC off, WDT enable	—	1.5	3.0	μA
		5V	enable	—	3.0	6.0	μA
I _{IDLE1}	IDLE1 Mode Standby Current (HXT)	3V	No load, ADC off, WDT enable, f _{SYS} =12MHz on	—	0.6	1.0	mA
		5V	enable, f _{SYS} =12MHz on	—	1.3	2.0	mA
	IDLE1 Mode Standby Current (HIRC)	3V	No load, ADC off, WDT enable, f _{SYS} =8MHz on	—	0.9	1.4	mA
		5V	enable, f _{SYS} =8MHz on	—	1.2	1.8	mA
I _{SLEEP0}	SLEEP0 Mode Standby Current (LIRC off)	3V	No load, ADC off, WDT disable	—	—	1	μA
		5V	disable	—	—	2	μA
I _{SLEEP1}	SLEEP1 Mode Standby Current (LIRC on)	3V	No load, ADC off, WDT enable	—	1.5	3.0	μA
		5V	enable	—	2.5	5.0	μA
V _{IL1}	Input Low Voltage for I/O Ports or Input Pin Except RES Pin	—	—	0	—	0.2V _{DD}	V
		5V	—	0	—	1.5	V
V _{IH1}	Input High Voltage for I/O Ports or Input Pin Except RES Pin	—	—	0.8V _{DD}	—	V _{DD}	V
		5V	—	3.5	—	5.0	V
V _{IL2}	Input Low Voltage for $\overline{\text{RES}}$	—	—	0	—	0.4V _{DD}	V
V _{IH2}	Input High Voltage for $\overline{\text{RES}}$	—	—	0.9V _{DD}	—	V _{DD}	V
V _{LVR1}	LVR Voltage Level	—	LVR Enable, 2.10V option	-5%	2.10	+5%	V
V _{LVR2}			LVR Enable, 2.55V option	-5%	2.55	+5%	V
V _{LVR3}			LVR Enable, 3.15V option	-5%	3.15	+5%	V
V _{LVR4}			LVR Enable, 3.80V option	-5%	3.80	+5%	V

Symbol	Parameter	Test Conditions		Min.	Typ.	Max.	Unit
		V _{DD}	Conditions				
V _{LVD1}	LVD Voltage Level	—	LVDEN=1, V _{LVD} =2.0V	-5%	2.00	+5%	V
V _{LVD2}			LVDEN=1, V _{LVD} =2.2V	-5%	2.20	+5%	V
V _{LVD3}			LVDEN=1, V _{LVD} =2.4V	-5%	2.40	+5%	V
V _{LVD4}			LVDEN=1, V _{LVD} =2.7V	-5%	2.70	+5%	V
V _{LVD5}			LVDEN=1, V _{LVD} =3.0V	-5%	3.00	+5%	V
V _{LVD6}			LVDEN=1, V _{LVD} =3.3V	-5%	3.30	+5%	V
V _{LVD7}			LVDEN=1, V _{LVD} =3.6V	-5%	3.60	+5%	V
V _{LVD8}			LVDEN=1, V _{LVD} =4.0V	-5%	4.00	+5%	V
I _{LVD1}	Additional Power Consumption if LVR and LVD is Used	—	LVR disable, LVDEN=1	—	75	120	μA
I _{LVD2}			LVR enable, LVDEN=1	—	90	150	μA
V _{OL}	Output Low Voltage I/O Port	3V	I _{OL} =9mA	—	—	0.3	V
		5V	I _{OL} =20mA	—	—	0.5	V
V _{OH}	Output High Voltage I/O Port	3V	I _{OH} =-3.2mA	2.7	—	—	V
		5V	I _{OH} =-7.4mA	4.5	—	—	V
R _{PH}	Pull-high Resistance for I/O Ports	3V	—	20	60	100	kΩ
		5V		10	30	50	kΩ
V ₁₂₅	1.25V Reference with Buffer Voltage	—	—	-3%	1.25	+3%	V
I ₁₂₅	Additional Power Consumption if 1.25V Reference with Buffer is used	—	—	—	200	300	μA

A.C. Characteristics

Ta=25°C

Symbol	Parameter	Test Conditions		Min.	Typ.	Max.	Unit
		V _{DD}	Conditions				
f _{CPU}	Operating Clock	—	2.2V~5.5V	DC	—	8	MHz
			2.7V~5.5V	DC	—	12	MHz
			4.5V~5.5V	DC	—	20	MHz
f _{SYS}	System Clock (HXT)	—	2.2V~5.5V	0.4	—	8	MHz
			2.7V~5.5V	0.4	—	12	MHz
			4.5V~5.5V	0.4	—	20	MHz
f _{HIRC}	System Clock (HIRC)	3.0V~5.5V	Ta= -40°C~85°C	-6%	8	+6%	MHz
		4.5V~5.5V	Ta= -40°C~85°C	-2%	8	+2%	MHz
f _{LIRC}	System Clock (LIRC)	5V	Ta=25°C	-10%	32	+10%	kHz
		2.2V~5.5V	Ta= -40°C~85°C	-30%	32	+60%	kHz
t _{RES}	External Reset Low Pulse Width	—	—	1	—	—	μs
t _{INT}	Interrupt Pulse Width	—	—	10	—	—	μs
t _{LVR}	Low Voltage Width to Reset	—	—	120	240	480	μs
t _{LVD}	Low Voltage Width to Interrupt	—	—	20	45	90	μs
t _{LVDS}	LVDO stable time	—	For all V _{LVD} , LVR disable	200	—	—	μs
t _{BGS}	VBG Turn on Stable Time	—	—	200	—	—	μs
t _{TIMER}	TCKn Input Pulse Width	—	—	0.3	—	—	μs
t _{SRESET}	Software Reset Width to Reset	—	—	45	90	120	μs
t _{RSTD}	System Reset Delay Time (Power on Reset)	—	—	25	50	100	ms
	System Reset Delay Time (Any Reset except Power on Reset)	—	—	8.3	16.7	33.3	ms
t _{SST}	System Start-up Timer Period (Wake-up from HALT, f _{SYS} off at HALT State)	—	f _{SYS} =HXT OSC	128	—	—	t _{SYS}
			f _{SYS} =HIRC OSC	16	—	—	
			f _{SYS} =LIRC OSC	2	—	—	
	System Start-up Timer Period (Wake-up from HALT, f _{SYS} on at HALT State)	—	—	2	—	—	t _{SYS}
t _{EERD}	EEPROM Read Time	—	—	—	2	4	t _{SYS}
t _{EEWR}	EEPROM Write Time	—	—	—	2	4	ms

 Note: 1. t_{SYS}=1/f_{SYS}

- To maintain the accuracy of the internal HIRC oscillator frequency, a 0.1μF decoupling capacitor should be connected between VDD and VSS and located as close to the device as possible.

A/D Converter Characteristics

Ta=25°C

Symbol	Parameter	Test Conditions		Min.	Typ.	Max.	Unit
		V _{DD}	Conditions				
AV _{DD}	A/D Converter Operating Voltage	—	V _{REF} =AV _{DD}	2.7	—	5.5	V
V _{ADI}	A/D Converter Input Voltage	—	—	0	—	V _{REF}	V
V _{REF}	A/D Converter Reference Voltage	—	—	2	—	AV _{DD}	V
DNL	Differential Non-linearity	5V	t _{ADCK} = 1.0μs	—	±1	±2	LSB
INL	Integral Non-linearity	5V	t _{ADCK} = 1.0μs	—	±2	±4	LSB
I _{ADC}	Additional Power Consumption if A/D Converter is Used	3V	No load, t _{ADCK} = 0.5μs	—	0.90	1.35	mA
		5V	No load, t _{ADCK} = 0.5μs	—	1.20	1.80	mA
t _{ADCK}	A/D Converter Clock Period	2.2~5.5V	—	0.5	—	10	μs
t _{ADC}	A/D Conversion Time (Include Sample and Hold Time)	2.2~5.5V	12-bit A/D Converter	—	16	—	t _{ADCK}
t _{ADS}	A/D Converter Sampling Time	2.2~5.5V	—	—	4	—	t _{ADCK}
t _{ON2ST}	A/D Converter On-to-Start Time	2.2~5.5V	—	2	—	—	μs

Comparator Electrical Characteristics

Ta=25°C

Symbol	Parameter	Test Conditions		Min.	Typ.	Max.	Unit
		V _{DD}	Conditions				
V _{CMP}	Comparator Operating Voltage	—	—	2.2	—	5.5	V
I _{CMP}	Comparator Operating Current	3V	—	—	37	56	μA
		5V	—	—	130	200	μA
V _{CMPOS}	Comparator Input Offset Voltage	—	—	-10	—	10	mV
V _{HYS}	Hysteresis Width	—	—	20	40	60	mV
V _{CM}	Comparator Common Mode Voltage Range	—	—	V _{SS}	—	V _{DD} -1.4V	V
A _{OL}	Comparator Open Loop Gain	—	—	60	80	—	dB
t _{PD}	Comparator Response Time	—	With 100mV overdrive (Note)	—	370	560	ns

Note: Measured with comparator one input pin at V_{CM} = (V_{DD}-1.4)/2 while the other pin input transition from V_{SS} to (V_{CM} +100mV) or from V_{DD} to (V_{CM} -100mV).

Power-on Reset Characteristics

Ta=25°C

Symbol	Parameter	Test Conditions		Min.	Typ.	Max.	Unit
		V _{DD}	Conditions				
V _{POR}	VDD Start Voltage to Ensure Power-on Reset	—	—	—	—	100	mV
R _{POR AC}	VDD Raising Rate to Ensure Power-on Reset	—	—	0.035	—	—	V/ms
t _{POR}	Minimum Time for VDD Stays at V _{POR} to Ensure Power-on Reset	—	—	1	—	—	ms

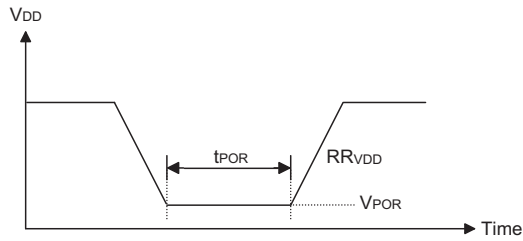

Bandgap Reference (V_{bg}) Characteristic Curve

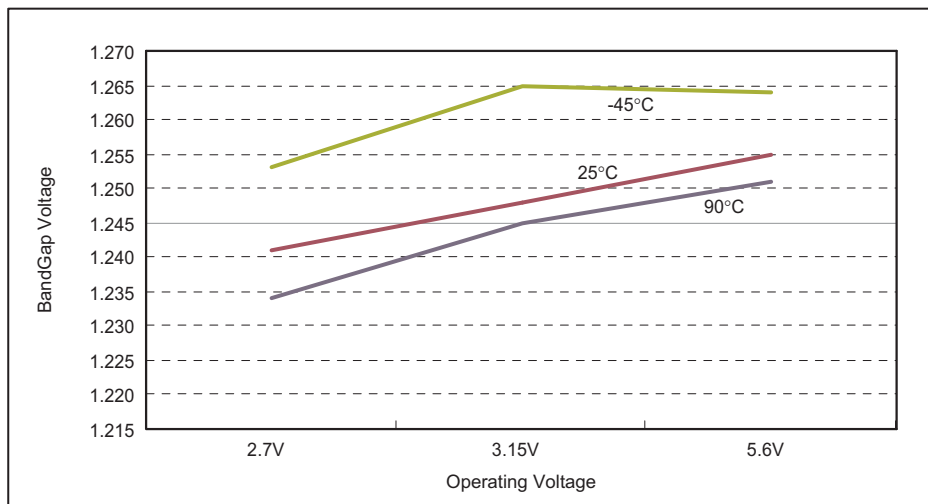

System Architecture

A key factor in the high-performance features of the Holtek range of microcontrollers is attributed to their internal system architecture. The range of devices take advantage of the usual features found within RISC microcontrollers providing increased speed of operation and enhanced performance. The pipelining scheme is implemented in such a way that instruction fetching and instruction execution are overlapped, hence instructions are effectively executed in one cycle, with the exception of branch or call instructions. An 8-bit wide ALU is used in practically all instruction set operations, which carries out arithmetic operations, logic operations, rotation, increment, decrement, branch decisions, etc. The internal data path is simplified by moving data through the Accumulator and the ALU. Certain internal registers are implemented in the Data Memory and can be directly or indirectly addressed. The simple addressing methods of these registers along with additional architectural features ensure that a minimum of external components is required to provide a functional I/O and A/D control system with maximum reliability and flexibility. This makes the device suitable for low-cost, high-volume production for controller applications.

generated non-overlapping clocks, T1~T4. The Program Counter is incremented at the beginning of the T1 clock during which time a new instruction is fetched. The remaining T2~T4 clocks carry out the decoding and execution functions. In this way, one T1~T4 clock cycle forms one instruction cycle. Although the fetching and execution of instructions takes place in consecutive instruction cycles, the pipelining structure of the microcontroller ensures that instructions are effectively executed in one instruction cycle. The exception to this are instructions here the contents of the Program Counter are changed, such as subroutine calls or jumps, in which case the instruction will take one more instruction cycle to execute.

For instructions involving branches, such as jump or call instructions, two machine cycles are required to complete instruction execution. An extra cycle is required as the program takes one cycle to first obtain the actual jump or call address and then another cycle to actually execute the branch. The requirement for this extra cycle should be taken into account by programmers in timing sensitive applications.

Clocking and Pipelining

The main system clock, derived from either a HXT, HIRC or LIRC oscillator is subdivided into four internally

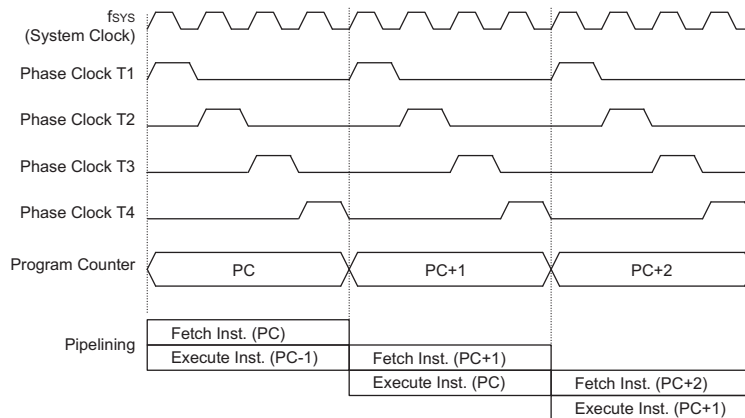

System Clocking and Pipelining

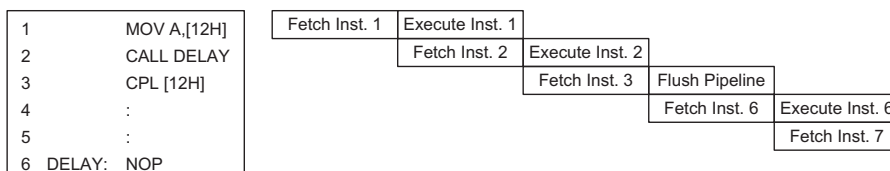

Instruction Fetching

Program Counter

During program execution, the Program Counter is used to keep track of the address of the next instruction to be executed. It is automatically incremented by one each time an instruction is executed except for instructions, such as "JMP" or "CALL" that demand a jump to a non-consecutive Program Memory address. Only the lower 8 bits, known as the Program Counter Low Register, are directly addressable by the application program.

When executing instructions requiring jumps to non-consecutive addresses such as a jump instruction, a subroutine call, interrupt or reset, etc., the microcontroller manages program control by loading the required address into the Program Counter. For conditional skip instructions, once the condition has been met, the next instruction, which has already been fetched during the present instruction execution, is discarded and a dummy cycle takes its place while the correct instruction is obtained.

Device	Program Counter	
	Program Counter High Byte	PCL Register
HT66F016 HT68F016	PC9~PC8	PCL7~PCL0
HT66F017 HT68F017	PC10~PC8	PCL7~PCL0

Program Counter

The lower byte of the Program Counter, known as the Program Counter Low register or PCL, is available for program control and is a readable and writeable register. By transferring data directly into this register, a short program jump can be executed directly, however, as only this low byte is available for manipulation, the jumps are limited to the present page of memory, that is 256 locations. When such program jumps are executed it should also be noted that a dummy cycle will be inserted. Manipulating the PCL register may cause program branching, so an extra cycle is needed to pre-fetch.

Stack

This is a special part of the memory which is used to save the contents of the Program Counter only. The stack has multiple levels depending upon the device and is neither part of the data nor part of the program space, and is neither readable nor writeable. The activated level is indexed by the Stack Pointer, and is neither readable nor writeable. At a subroutine call or interrupt acknowledge signal, the contents of the Program Counter are pushed onto the stack. At the end of a subroutine or an interrupt routine, signaled by a return instruction, RET or RETI, the Program Counter is restored to its previous value from the stack. After a device reset, the Stack Pointer will point to the top of the stack.

If the stack is full and an enabled interrupt takes place, the interrupt request flag will be recorded but the acknowledge signal will be inhibited. When the Stack Pointer is decremented, by RET or RETI, the interrupt will be serviced. This feature prevents stack overflow allowing the programmer to use the structure more easily. However, when the stack is full, a CALL subroutine instruction can still be executed which will result in a stack overflow. Precautions should be taken to avoid such cases which might cause unpredictable program branching.

If the stack is overflow, the first Program Counter save in the stack will be lost.

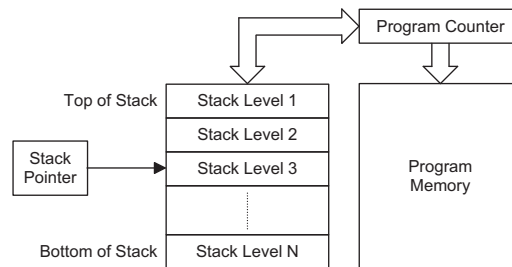

Device	Stack Levels
HT66F016, HT68F016	4
HT66F017, HT68F017	8

Arithmetic and Logic Unit – ALU

The arithmetic-logic unit or ALU is a critical area of the microcontroller that carries out arithmetic and logic operations of the instruction set. Connected to the main microcontroller data bus, the ALU receives related instruction codes and performs the required arithmetic or logical operations after which the result will be placed in the specified register. As these ALU calculation or operations may result in carry, borrow or other status changes, the status register will be correspondingly updated to reflect these changes. The ALU supports the following functions:

- Arithmetic operations: ADD, ADDM, ADC, ADCM, SUB, SUBM, SBC, SBCM, DAA
- Logic operations: AND, OR, XOR, ANDM, ORM, XORM, CPL, CPLA
- Rotation RRA, RR, RRCA, RRC, RLA, RL, RLCA, RLC
- Increment and Decrement INCA, INC, DECA, DEC
- Branch decision, JMP, SZ, SZA, SNZ, SIZ, SDZ, SIZA, SDZA, CALL, RET, RETI

Flash Program Memory

The Program Memory is the location where the user code or program is stored. For this device series the Program Memory is Flash type, which means it can be programmed and re-programmed a large number of times, allowing the user the convenience of code modification on the same device. By using the appropriate programming tools, these Flash devices offer users the flexibility to conveniently debug and develop their applications while also offering a means of field programming and updating.

Structure

The Program Memory has a capacity of 2K×16 bits. The Program Memory is addressed by the Program Counter and also contains data, table information and interrupt entries. Table data, which can be setup in any location within the Program Memory, is addressed by a separate table pointer register.

Device	Capacity
HT66F016, HT68F016	1K×16
HT66F017, HT68F017	2K×16

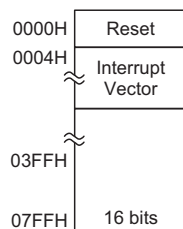

Program Memory Structure

Special Vectors

Within the Program Memory, certain locations are reserved for the reset and interrupts. The location 000H is reserved for use by the device reset for program initialisation. After a device reset is initiated, the program will jump to this location and begin execution.

Look-up Table

Any location within the Program Memory can be defined as a look-up table where programmers can store fixed data. To use the look-up table, the table pointer must first be setup by placing the address of the look up data to be retrieved in the table pointer register, TBLP and TBHP. These registers define the total address of the look-up table.

After setting up the table pointer, the table data can be retrieved from the Program Memory using the "TABRD[m]" or "TABRDL[m]" instructions, respectively. When the instruction is executed, the lower order table

byte from the Program Memory will be transferred to the user defined Data Memory register [m] as specified in the instruction. The higher order table data byte from the Program Memory will be transferred to the TBLH special register. Any unused bits in this transferred higher order byte will be read as "0".

The accompanying diagram illustrates the addressing data flow of the look-up table.

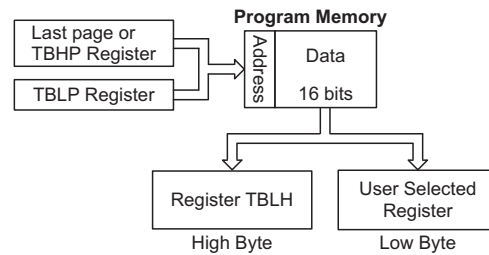

Table Program Example

The following example shows how the table pointer and table data is defined and retrieved from the microcontroller. This example uses raw table data located in the Program Memory which is stored there using the ORG statement. The value at this ORG statement is "700H" which refers to the start address of the last page within the 2K words Program Memory of the device. The table pointer is setup here to have an initial value of "06H". This will ensure that the first data read from the data table will be at the Program Memory address "706H" or 6 locations after the start of the last page. Note that the value for the table pointer is referenced to the first address of the present page if the "TABRD [m]" instruction is being used. The high byte of the table data which in this case is equal to zero will be transferred to the TBLH register automatically when the "TABRD [m]" instruction is executed.

Because the TBLH register is a read-only register and cannot be restored, care should be taken to ensure its protection if both the main routine and Interrupt Service Routine use table read instructions. If using the table read instructions, the Interrupt Service Routines may change the value of the TBLH and subsequently cause errors if used again by the main routine. As a rule it is recommended that simultaneous use of the table read instructions should be avoided. However, in situations where simultaneous use cannot be avoided, the interrupts should be disabled prior to the execution of any main routine table-read instructions. Note that all table related instructions require two instruction cycles to complete their operation.

• **Table Read Program Example**

```

tempreg1 db    ?    ; temporary register #1
tempreg2 db    ?    ; temporary register #2
:
:
mov a,06h      ; initialise low table pointer - note that this address
mov tblp,a    ; is referenced
mov a,07h      ; initialise high table pointer
tblhp,a
:
:
tabrd tempreg1 ; transfers value in table referenced by table pointer data at program
                ; memory address "706H" transferred to tempreg1 and TBLH

dec tblp      ; reduce value of table pointer by one

tabrd tempreg2 ; transfers value in table referenced by table pointer data at program
                ; memory address "705H" transferred to tempreg2 and TBLH in this
                ; example the data "1AH" is transferred to tempreg1 and data "0FH" to
                ; register tempreg2
:
:
org 700h      ; sets initial address of program memory

dc 00Ah, 00Bh, 00Ch, 00Dh, 00Eh, 00Fh, 01Ah, 01Bh
:
:

```

In Circuit Programming

The provision of Flash type Program Memory provides the user with a means of convenient and easy upgrades and modifications to their programs on the same device.

As an additional convenience, Holtek has provided a means of programming the microcontroller in-circuit using a 5-pin interface. This provides manufacturers with the possibility of manufacturing their circuit boards complete with a programmed or un-programmed microcontroller, and then programming or upgrading the program at a later stage. This enables product manufacturers to easily keep their manufactured products supplied with the latest program releases without removal and re-insertion of the device.

The Program Memory can be programmed serially in-circuit using this 5-wire interface. Data is downloaded and uploaded serially on a single pin with an additional line for the clock. Two additional lines are required for the power supply and one line for the reset. The technical details regarding the in-circuit programming of the devices are beyond the scope of this document and will be supplied in supplementary literature.

During the programming process the ICPMS pin will be held low by the programmer disabling the normal operation of the microcontroller and taking control of the PA0 and PA2 I/O pins for data and clock programming purposes. The user must there take care to ensure that no other outputs are connected to these two pins

Holtek Writer Pins	MCU Programming Pins	Pin Description
ICPMS	PA7/ $\overline{\text{RES}}$	Programming Mode Select
ICPDA	PA0	Programming Serial Data
ICPCK	PA2	Programming Clock
VDD	VDD	Power Supply
VSS	VSS	Ground

Programmer and MCU Pins

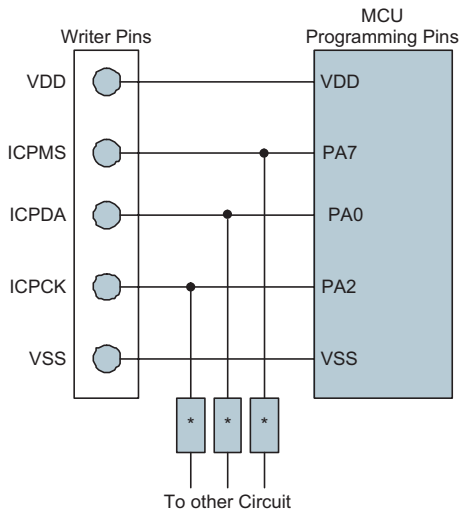

Note: * may be resistor or capacitor. The resistance of * must be greater than 1kΩ or the capacitance of * must be less than 1nF.

RAM Data Memory

The Data Memory is a volatile area of 8-bit wide RAM internal memory and is the location where temporary information is stored.

Structure

Divided into two sections, the first of these is an area of RAM, known as the Special Function Data Memory. Here are located registers which are necessary for correct operation of the device. Many of these registers can be read from and written to directly under program control, however, some remain protected from user manipulation.

Device	Capacity	Bank 0	Bank 1
HT66F016 HT68F016	64×8	80H~BFH	Unimplemented
HT66F017 HT68F017	128×8	80H~FFH	Unimplemented

General Purpose Data Memory Structure

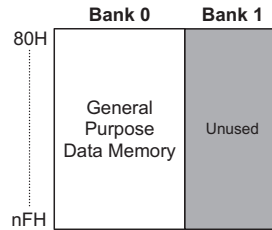

Note: General Purpose Data Memory space:
80H~BFH for HT66F016/HT68F016
80H~FFH for HT66F017/HT68F017

General Purpose Data Memory

The second area of Data Memory is known as the General Purpose Data Memory, which is reserved for general purpose use. All locations within this area are read and write accessible under program control.

The overall Data Memory is subdivided into two banks for all the devices. The Special Purpose Data Memory registers are accessible in all banks, with the exception of the EEC register at address 40H, which is only accessible in Bank 1. Switching between the different Data Memory banks is achieved by setting the Bank Pointer to the correct value. The start address of the Data Memory for all devices is the address 00H.

Bank 0		Bank 1	Bank 0		Bank 1
00H	IAR0		20H	ADRL	
01H	MP0		21H	ADRH	
02H	IAR1		22H	ADCR0	
03H	MP1		23H	ADCR1	
04H	BP		24H	ACERL	
05H	ACC		25H	CPC	
06H	PCL		26H	CTRL	
07H	TBLP		27H	LVRC	
08H	TBLH		28H	Unused	
09H	TBHP		29H	Unused	
0AH	STATUS		2AH	Unused	
0BH	SMOD		2BH	Unused	
0CH	LVDC		2CH	Unused	
0DH	INTEG		2DH	Unused	
0EH	INTC0		2EH	Unused	
0FH	INTC1		2FH	TM1C0	
10H	INTC2		30H	TM1C1	
11H	MF10		31H	TM1DL	
12H	MF11		32H	TM1DH	
13H	MF12		33H	TM1AL	
14H	PA		34H	TM1AH	
15H	PAC		35H	TM1RP	
16H	PAPU		36H	Unused	
17H	PAWU		37H	Unused	
18H	PRM		38H	Unused	
19H	TMPC		39H	Unused	
1AH	WDTC		3CH	PB	
1BH	TBC		3DH	PBC	
1CH	Unused		3EH	PBC	
1DH	Unused		3FH	PBPU	
1EH	EEA		40H	Unused	EEC
1FH	EED		41H	Unused	EEC
			42H	Unused	
			43H	Unused	
			44H	Unused	
			45H	Unused	
			46H	Unused	
			47H	Unused	
			48H	Unused	
			49H	Unused	
			4AH	Unused	
			4BH	Unused	
			4CH	Unused	
			4DH	Unused	
			4EH	Unused	
			4FH	Unused	
			50H	Unused	
			51H	Unused	
			52H	Unused	
			53H	Unused	
			54H	Unused	
			55H	Unused	
			56H	Unused	
			57H	Unused	
			58H	Unused	
			59H	Unused	
			5AH	Unused	
			5BH	Unused	
			5CH	Unused	
			5DH	Unused	
			5EH	Unused	
			5FH	Unused	
			60H	Unused	
			61H	Unused	
			62H	Unused	
			63H	Unused	
			64H	Unused	
			65H	Unused	
			66H	Unused	
			67H	Unused	
			68H	Unused	
			69H	Unused	
			6AH	Unused	
			6BH	Unused	
			6CH	Unused	
			6DH	Unused	
			6EH	Unused	
			6FH	Unused	
			70H	Unused	
			71H	Unused	
			72H	Unused	
			73H	Unused	
			74H	Unused	
			75H	Unused	
			76H	Unused	
			77H	Unused	
			78H	Unused	
			79H	Unused	
			7AH	Unused	
			7BH	Unused	
			7CH	Unused	
			7DH	Unused	
			7EH	Unused	
			7FH	Unused	

Unused, read as "00"

HT66F016/HT68F016 Special Purpose Data Memory

Note: note: address 20H~24H are unimplemented for HT68F016

Bank 0		Bank 1	Bank 0		Bank 1
00H	IAR0		20H	ADRL	
01H	MP0		21H	ADRH	
02H	IAR1		22H	ADCR0	
03H	MP1		23H	ADCR1	
04H	BP		24H	ACERL	
05H	ACC		25H	CPC	
06H	PCL		26H	CTRL	
07H	TBLP		27H	LVRC	
08H	TBLH		28H	TM0C0	
09H	TBHP		29H	TM0C1	
0AH	STATUS		2AH	TM0DL	
0BH	SMOD		2BH	TM0DH	
0CH	LVDC		2CH	TM0AL	
0DH	INTEG		2DH	TM0AH	
0EH	INTC0		2EH	TM0RP	
0FH	INTC1		2FH	TM1C0	
10H	INTC2		30H	TM1C1	
11H	MF10		31H	TM1DL	
12H	MF11		32H	TM1DH	
13H	MF12		33H	TM1AL	
14H	PA		34H	TM1AH	
15H	PAC		35H	TM1RP	
16H	PAPU		36H	Unused	
17H	PAWU		37H	Unused	
18H	PRM		38H	Unused	
19H	TMPC		39H	Unused	
1AH	WDTC		3CH	PB	
1BH	TBC		3DH	PBC	
1CH	Unused		3EH	PBC	
1DH	Unused		3FH	PBPU	
1EH	EEA		40H	Unused	EEC
1FH	EED		41H	Unused	EEC
			42H	Unused	
			43H	Unused	
			44H	Unused	
			45H	Unused	
			46H	Unused	
			47H	Unused	
			48H	Unused	
			49H	Unused	
			4AH	Unused	
			4BH	Unused	
			4CH	Unused	
			4DH	Unused	
			4EH	Unused	
			4FH	Unused	
			50H	Unused	
			51H	Unused	
			52H	Unused	
			53H	Unused	
			54H	Unused	
			55H	Unused	
			56H	Unused	
			57H	Unused	
			58H	Unused	
			59H	Unused	
			5AH	Unused	
			5BH	Unused	
			5CH	Unused	
			5DH	Unused	
			5EH	Unused	
			5FH	Unused	
			60H	Unused	
			61H	Unused	
			62H	Unused	
			63H	Unused	
			64H	Unused	
			65H	Unused	
			66H	Unused	
			67H	Unused	
			68H	Unused	
			69H	Unused	
			6AH	Unused	
			6BH	Unused	
			6CH	Unused	
			6DH	Unused	
			6EH	Unused	
			6FH	Unused	
			70H	Unused	
			71H	Unused	
			72H	Unused	
			73H	Unused	
			74H	Unused	
			75H	Unused	
			76H	Unused	
			77H	Unused	
			78H	Unused	
			79H	Unused	
			7AH	Unused	
			7BH	Unused	
			7CH	Unused	
			7DH	Unused	
			7EH	Unused	
			7FH	Unused	

Unused, read as "00"

HT66F017/HT68F017 Special Purpose Data Memory

Note: note: address 20H~24H are unimplemented for HT68F017

Special Function Register Description

Most of the Special Function Register details will be described in the relevant functional section, however several registers require a separate description in this section.

Indirect Addressing Registers – IAR0, IAR1

The Indirect Addressing Registers, IAR0 and IAR1, although having their locations in normal RAM register space, do not actually physically exist as normal registers. The method of indirect addressing for RAM data manipulation uses these Indirect Addressing Registers and Memory Pointers, in contrast to direct memory addressing, where the actual memory address is specified. Actions on the IAR0 and IAR1 registers will result in no actual read or write operation to these registers but rather to the memory location specified by their corresponding Memory Pointers, MP0 or MP1. Acting as a pair, IAR0 and MP0 can together access data from Bank 0 while the IAR1 and MP1 register pair can access data from any bank. As the Indirect Addressing Registers are not physically implemented, reading the Indirect Addressing Registers indirectly will return a result of "00H" and writing to the registers indirectly will result in no operation.

Memory Pointers – MP0, MP1

Two Memory Pointers, known as MP0 and MP1 are provided. These Memory Pointers are physically implemented in the Data Memory and can be manipulated in the same way as normal registers providing a convenient way with which to address and track data. When any operation to the relevant Indirect Addressing Registers is carried out, the actual address that the microcontroller is directed to, is the address specified by the related Memory Pointer. MP0, together with Indirect Addressing Register, IAR0, are used to access data from Bank 0, while MP1 and IAR1 are used to access data from all banks according to BP register. Direct Addressing can only be used with Bank 0, all other Banks must be addressed indirectly using MP1 and IAR1. Note that for this series of devices, the Memory Pointers, MP0 and MP1, are both 8-bit registers and used to access the Data Memory together with their corresponding indirect addressing registers IAR0 and IAR1.

The following example shows how to clear a section of four Data Memory locations already defined as locations `adres1` to `adres4`.

• Indirect Addressing Program Example

```
data .section 'data'
adres1 db ?
adres2 db ?
adres3 db ?
adres4 db ?
block db ?
code .section at 0 'code'
org 00h

start:
mov a,04h ; setup size of block
mov block,a
mov a,offset adres1 ; Accumulator loaded with first RAM address
mov mp0,a ; setup memory pointer with first RAM address

loop:
clr IAR0 ; clear the data at address defined by MP0
inc mp0 ; increment memory pointer
sdz block ; check if last memory location has been cleared
jmp loop

continue:
```

The important point to note here is that in the example shown above, no reference is made to specific RAM addresses.

Bank Pointer – BP

For this series of devices, the Data Memory is divided into two banks. Selecting the required Data Memory area is achieved using the Bank Pointer. Bit 0 is used to select Data Memory Banks 0~1.

The Data Memory is initialised to Bank 0 after a reset, except for a WDT time-out reset in the Power Down Mode, in which case, the Data Memory bank remains unaffected. It should be noted that the Special Function Data Memory is not affected by the bank selection, which means that the Special Function Registers can be accessed from within any bank. Directly addressing the Data Memory will always result in Bank 0 being accessed irrespective of the value of the Bank Pointer. Accessing data from banks other than Bank 0 must be implemented using indirect addressing.

Accumulator – ACC

The Accumulator is central to the operation of any microcontroller and is closely related with operations carried out by the ALU. The Accumulator is the place where all intermediate results from the ALU are stored. Without the Accumulator it would be necessary to write the result of each calculation or logical operation such as addition, subtraction, shift, etc., to the Data Memory resulting in higher programming and timing overheads. Data transfer operations usually involve the temporary storage function of the Accumulator; for example, when transferring data between one user defined register and another, it is necessary to do this by passing the data through the Accumulator as no direct transfer between two registers is permitted.

Program Counter Low Register – PCL

To provide additional program control functions, the low byte of the Program Counter is made accessible to programmers by locating it within the Special Purpose area of the Data Memory. By manipulating this register, direct jumps to other program locations are easily implemented. Loading a value directly into this PCL register will cause a jump to the specified Program Memory location, however, as the register is only 8-bit wide, only jumps within the current Program Memory page are permitted. When such operations are used, note that a dummy cycle will be inserted.

Look-up Table Registers – TBLP, TBHP, TBLH

These three special function registers are used to control operation of the look-up table which is stored in the Program Memory. TBLP and TBHP are the table pointer and indicates the location where the table data is located. Their value must be setup before any table read commands are executed. Their value can be changed, for example using the "INC" or "DEC" instructions, allowing for easy table data pointing and reading. TBLH is the location where the high order byte of the table data is stored after a table read data instruction has been executed. Note that the lower order table data byte is transferred to a user defined location.

• Bank Pointer Register

Bit	7	6	5	4	3	2	1	0
Name	—	—	—	—	—	—	—	DMBP0
R/W	—	—	—	—	—	—	—	R/W
POR	—	—	—	—	—	—	—	0

Bit 7 ~ 1 Unimplemented, read as "0"
 Bit 0 **DMBP0**: Select Data Memory Banks
 0: Bank 0
 1: Bank 1

Status Register – STATUS

This 8-bit register contains the zero flag (Z), carry flag (C), auxiliary carry flag (AC), overflow flag (OV), power down flag (PDF), and watchdog time-out flag (TO). These arithmetic/logical operation and system management flags are used to record the status and operation of the microcontroller.

With the exception of the TO and PDF flags, bits in the status register can be altered by instructions like most other registers. Any data written into the status register will not change the TO or PDF flag. In addition, operations related to the status register may give different results due to the different instruction operations. The TO flag can be affected only by a system power-up, a WDT time-out or by executing the "CLR WDT" or "HALT" instruction. The PDF flag is affected only by executing the "HALT" or "CLR WDT" instruction or during a system power-up.

The Z, OV, AC and C flags generally reflect the status of the latest operations.

- **C** is set if an operation results in a carry during an addition operation or if a borrow does not take place during a subtraction operation; otherwise C is cleared. C

is also affected by a rotate through carry instruction.

- **AC** is set if an operation results in a carry out of the low nibbles in addition, or no borrow from the high nibble into the low nibble in subtraction; otherwise AC is cleared.
- **Z** is set if the result of an arithmetic or logical operation is zero; otherwise Z is cleared.
- **OV** is set if an operation results in a carry into the highest-order bit but not a carry out of the highest-order bit, or vice versa; otherwise OV is cleared.
- **PDF** is cleared by a system power-up or executing the "CLR WDT" instruction. PDF is set by executing the "HALT" instruction.
- **TO** is cleared by a system power-up or executing the "CLR WDT" or "HALT" instruction. TO is set by a WDT time-out.

In addition, on entering an interrupt sequence or executing a subroutine call, the status register will not be pushed onto the stack automatically. If the contents of the status registers are important and if the subroutine can corrupt the status register, precautions must be taken to correctly save it.

• STATUS Register

Bit	7	6	5	4	3	2	1	0
Name	—	—	TO	PDF	OV	Z	AC	C
R/W	—	—	R	R	R/W	R/W	R/W	R/W
POR	—	—	0	0	x	x	x	x

"x" unknown

- Bit 7, 6 Unimplemented, read as "0"
- Bit 5 **TO**: Watchdog Time-Out flag
0: After power up or executing the "CLR WDT" or "HALT" instruction
1: A watchdog time-out occurred.
- Bit 4 **PDF**: Power down flag
0: After power up or executing the "CLR WDT" instruction
1: By executing the "HALT" instruction
- Bit 3 **OV**: Overflow flag
0: no overflow
1: an operation results in a carry into the highest-order bit but not a carry out of the highest-order bit or vice versa.
- Bit 2 **Z**: Zero flag
0: The result of an arithmetic or logical operation is not zero
1: The result of an arithmetic or logical operation is zero
- Bit 1 **AC**: Auxiliary flag
0: no auxiliary carry
1: an operation results in a carry out of the low nibbles in addition, or no borrow from the high nibble into the low nibble in subtraction
- Bit 0 **C**: Carry flag
0: no carry-out
1: an operation results in a carry during an addition operation or if a borrow does not take place during a subtraction operation
C is also affected by a rotate through carry instruction.

EEPROM Data Memory

The device contains an area of internal EEPROM Data Memory. EEPROM, which stands for Electrically Erasable Programmable Read Only Memory, is by its nature a non-volatile form of re-programmable memory, with data retention even when its power supply is removed. By incorporating this kind of data memory, a whole new host of application possibilities are made available to the designer. The availability of EEPROM storage allows information such as product identification numbers, calibration values, specific user data, system setup data or other product information to be stored directly within the product microcontroller. The process of reading and writing data to the EEPROM memory has been reduced to a very trivial affair.

EEPROM Data Memory Structure

The EEPROM Data Memory capacity is 64×8 bits for this series of devices. Unlike the Program Memory and RAM Data Memory, the EEPROM Data Memory is not directly mapped into memory space and is therefore not directly addressable in the same way as the other types of memory. Read and Write operations to the EEPROM are carried out in single byte operations using an address and data register in Bank 0 and a single control register in Bank 1.

Device	Capacity	Address
All devices	64×8	00H ~ 3FH

EEPROM Registers

Three registers control the overall operation of the internal EEPROM Data Memory. These are the address register, EEA, the data register, EED and a single control register, EEC. As both the EEA and EED registers are located in Bank 0, they can be directly accessed in the same way as any other Special Function Register. The EEC register however, being located in Bank1, cannot be addressed directly and can only be read from or written to indirectly using the MP1 Memory Pointer and Indirect Addressing Register, IAR1. Because the EEC control register is located at address 40H in Bank 1, the MP1 Memory Pointer must first be set to the value 40H and the Bank Pointer register, BP, set to the value, 01H, before any operations on the EEC register are executed.

• EEPROM Register List

Name	Bit							
	7	6	5	4	3	2	1	0
EEA	—	—	D5	D4	D3	D2	D1	D0
EED	D7	D6	D5	D4	D3	D2	D1	D0
EEC	—	—	—	—	WREN	WR	RDEN	RD

• EEA Register

Bit	7	6	5	4	3	2	1	0
Name	—	—	D5	D4	D3	D2	D1	D0
R/W	—	—	R/W	R/W	R/W	R/W	R/W	R/W
POR	—	—	x	x	x	x	x	x

"x" unknown

Bit 7 ~ 6 Unimplemented, read as "0"
 Bit 5 ~ 0 Data EEPROM address
 Data EEPROM address bit 5 ~ bit 0

• EEC Register

Bit	7	6	5	4	3	2	1	0
Name	—	—	—	—	WREN	WR	RDEN	RD
R/W	—	—	—	—	R/W	R/W	R/W	R/W
POR	—	—	—	—	0	0	0	0

Bit 7 ~ 4 Unimplemented, read as "0"

Bit 3 **WREN**: Data EEPROM Write Enable
0: Disable
1: Enable

This is the Data EEPROM Write Enable Bit which must be set high before Data EEPROM write operations are carried out. Clearing this bit to zero will inhibit Data EEPROM write operations.

Bit 2 **WR**: EEPROM Write Control
0: Write cycle has finished
1: Activate a write cycle

This is the Data EEPROM Write Control Bit and when set high by the application program will activate a write cycle. This bit will be automatically reset to zero by the hardware after the write cycle has finished. Setting this bit high will have no effect if the WREN has not first been set high.

Bit 1 **RDEN**: Data EEPROM Read Enable
0: Disable
1: Enable

This is the Data EEPROM Read Enable Bit which must be set high before Data EEPROM read operations are carried out. Clearing this bit to zero will inhibit Data EEPROM read operations.

Bit 0 **RD**: EEPROM Read Control
0: Read cycle has finished
1: Activate a read cycle

This is the Data EEPROM Read Control Bit and when set high by the application program will activate a read cycle. This bit will be automatically reset to zero by the hardware after the read cycle has finished. Setting this bit high will have no effect if the RDEN has not first been set high.

Note: The WREN, WR, RDEN and RD can not be set to "1" at the same time in one instruction. The WR and RD can not be set to "1" at the same time.

• EED Register

Bit	7	6	5	4	3	2	1	0
Name	D7	D6	D5	D4	D3	D2	D1	D0
R/W	R/W	R/W	R/W	R/W	R/W	R/W	R/W	R/W
POR	x	x	x	x	x	x	x	x

"x" unknown

Bit 7 ~ 0 Data EEPROM address
Data EEPROM address bit 7 ~ bit 0

Reading Data from the EEPROM

To read data from the EEPROM, the read enable bit, RDEN, in the EEC register must first be set high to enable the read function. The EEPROM address of the data to be read must then be placed in the EEA register. If the RD bit in the EEC register is now set high, a read cycle will be initiated. Setting the RD bit high will not initiate a read operation if the RDEN bit has not been set. When the read cycle terminates, the RD bit will be automatically cleared to zero, after which the data can be read from the EED register. The data will remain in the EED register until another read or write operation is executed. The application program can poll the RD bit to determine when the data is valid for reading.

Writing Data to the EEPROM

The EEPROM address of the data to be written must first be placed in the EEA register and the data placed in the EED register. To write data to the EEPROM, the write enable bit, WREN, in the EEC register must first be set high to enable the write function. After this, the WR bit in the EEC register must be immediately set high to initiate a write cycle. These two instructions must be executed consecutively. The global interrupt bit EMI should also first be cleared before implementing any write operations, and then set again after the write cycle has started. Note that setting the WR bit high will not initiate a write cycle if the WREN bit has not been set. As the EEPROM write cycle is controlled using an internal timer whose operation is asynchronous to microcontroller system clock, a certain time will elapse before the data will have been written into the EEPROM. Detecting when the write cycle has finished can be implemented either by polling the WR bit in the EEC register or by using the EEPROM interrupt. When the write cycle terminates, the WR bit will be automatically cleared to zero by the microcontroller, informing the user that the data has been written to the EEPROM. The application program can therefore poll the WR bit to determine when the write cycle has ended.

Write Protection

Protection against inadvertent write operation is provided in several ways. After the device is powered-on

the Write Enable bit in the control register will be cleared preventing any write operations. Also at power-on the Bank Pointer, BP, will be reset to zero, which means that Data Memory Bank 0 will be selected. As the EEPROM control register is located in Bank 1, this adds a further measure of protection against spurious write operations. During normal program operation, ensuring that the Write Enable bit in the control register is cleared will safeguard against incorrect write operations.

EEPROM Interrupt

The EEPROM write interrupt is generated when an EEPROM write cycle has ended. The EEPROM interrupt must first be enabled by setting the DEE bit in the relevant interrupt register. However as the EEPROM is contained within a Multi-function Interrupt, the associated multi-function interrupt enable bit must also be set. When an EEPROM write cycle ends, the DEF request flag and its associated multi-function interrupt request flag will both be set. If the global, EEPROM and Multi-function interrupts are enabled and the stack is not full, a jump to the associated Multi-function Interrupt vector will take place. When the interrupt is serviced only the Multi-function interrupt flag will be automatically reset, the EEPROM interrupt flag must be manually reset by the application program. More details can be obtained in the Interrupt section.

Programming Considerations

Care must be taken that data is not inadvertently written to the EEPROM. Protection can be enhanced by ensuring that the Write Enable bit is normally cleared to zero when not writing. Also the Bank Pointer could be normally cleared to zero as this would inhibit access to Bank 1 where the EEPROM control register exist. Although certainly not necessary, consideration might be given in the application program to the checking of the validity of new write data by a simple read back process.

When writing data the WR bit must be set high immediately after the WREN bit has been set high, to ensure the write cycle executes correctly. The global interrupt bit EMI should also be cleared before a write cycle is executed and then re-enabled after the write cycle starts.

• Programming Examples

♦ Reading data from the EEPROM - polling method

```
MOV A, EEPROM_ADRES      ; user defined address
MOV EEA, A
MOV A, 040H              ; setup memory pointer MP1
MOV MP1, A               ; MP1 points to EEC register
MOV A, 01H               ; setup Bank Pointer
MOV BP, A
SET IAR1.1               ; set RDEN bit, enable read operations
SET IAR1.0               ; start Read Cycle - set RD bit
BACK:
SZ IAR1.0                ; check for read cycle end
JMP BACK
CLR IAR1                 ; disable EEPROM read/write
CLR BP
MOV A, EED               ; move read data to register
MOV READ_DATA, A
```

♦ Writing Data to the EEPROM – polling method

```
CLR EMI
MOV A, EEPROM_ADRES     ; user defined address
MOV EEA, A
MOV A, EEPROM_DATA      ; user defined data
MOV EED, A
MOV A, 040H             ; setup memory pointer MP1
MOV MP1, A              ; MP1 points to EEC register
MOV A, 01H              ; setup Bank Pointer
MOV BP, A
SET IAR1.3              ; set WREN bit, enable write operations
SET IAR1.2              ; Start Write Cycle - set WR bit - executed immediately
                        ; after set WREN bit

SET EMI
BACK:
SZ IAR1.2               ; check for write cycle end
JMP BACK
CLR IAR1                ; disable EEPROM read/write
CLR BP
```

Oscillator

Various oscillator options offer the user a wide range of functions according to their various application requirements. The flexible features of the oscillator functions ensure that the best optimisation can be achieved in terms of speed and power saving. Oscillator selections and operation are selected through a combination of configuration options and registers.

Oscillator Overview

In addition to being the source of the main system clock the oscillators also provide clock sources for the Watchdog Timer and Time Base Interrupts. External oscillators requiring some external components as well as fully integrated internal oscillators, requiring no external components, are provided to form a wide range of both fast and slow system oscillators. All oscillator options are selected through the configuration options. The higher frequency oscillators provide higher performance but carry with it the disadvantage of higher power requirements, while the opposite is of course true for the lower frequency oscillators. With the capability of dynamically switching between fast and slow system clock, the device has the flexibility to optimize the performance/power ratio, a feature especially important in power sensitive portable applications.

Type	Name	Freq.	Pins
External Crystal	HXT	400kHz~20MHz	OSC1/OSC2
Internal High Speed RC	HIRC	8MHz	—
Internal Low Speed RC	LIRC	32kHz	—

Oscillator Types

System Clock Configurations

There are methods of generating the system clock, two high speed oscillators and one low speed oscillators. The high speed oscillators are the external crystal/ceramic oscillator - HXT and the internal 8MHz RC oscillator - HIRC. The low speed oscillator is the internal 32kHz oscillator - LIRC. Selecting whether the low or high speed oscillator is used as the system oscillator is implemented using the HLCLK bit and CKS2~CKS0 bits in the SMOD register and as the system clock can be dynamically selected.

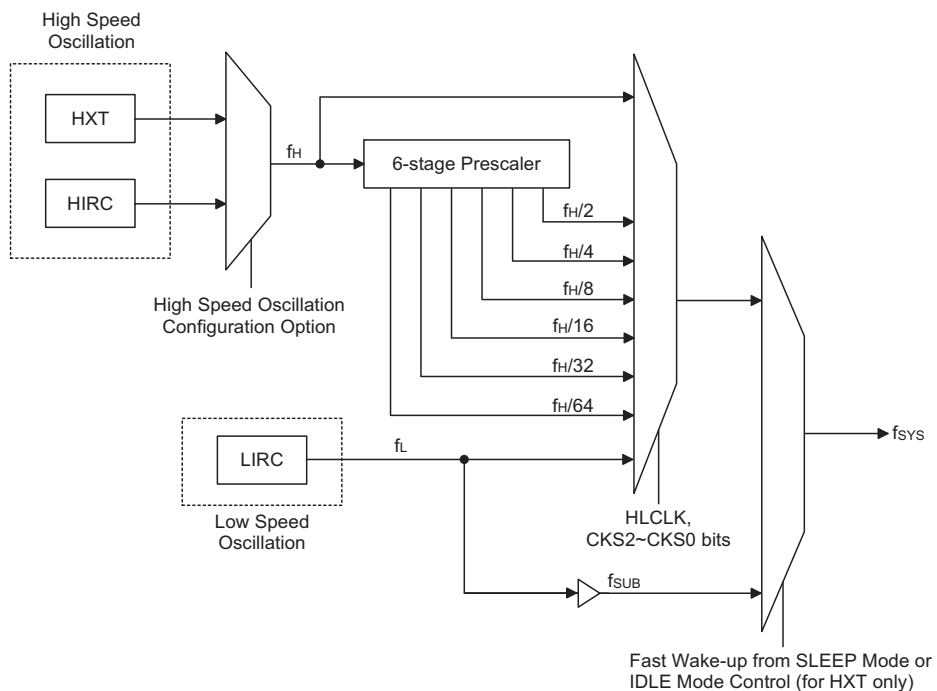

System Clock Configurations

The actual source clock used for each of the high speed oscillator is chosen via configuration options. The frequency of the slow speed or high speed system clock is also determined using the HLCLK bit and CKS2~CKS0 bits in the SMOD register. Note that two oscillator selections must be made namely one high speed and one low speed system oscillators. It is not possible to choose a no-oscillator selection for either the high or low speed oscillator. The OSC1 and OSC2 pins are used to connect the external components for the external crystal.

External Crystal/Ceramic Oscillator – HXT

The External Crystal/ Ceramic System Oscillator is one of the high frequency oscillator choices, which is selected via configuration option. For most crystal oscillator configurations, the simple connection of a crystal across OSC1 and OSC2 will create the necessary phase shift and feedback for oscillation, without requiring external capacitors. However, for some crystal types and frequencies, to ensure oscillation, it may be necessary to add two small value capacitors, C1 and C2. Using a ceramic resonator will usually require two small value capacitors, C1 and C2, to be connected as shown for oscillation to occur. The values of C1 and C2 should be selected in consultation with the crystal or resonator manufacturer’s specification.

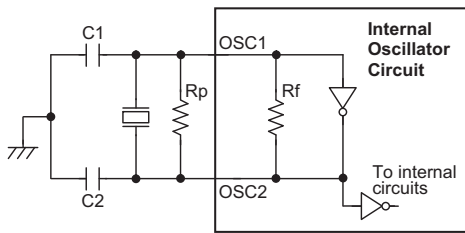

Note: 1. Rp is normally not required. C1 and C2 are required.
2. Although not shown OSC1/OSC2 pins have a parasitic capacitance of around 7pF.

Crystal/Resonator Oscillator – HXT

Crystal Oscillator C1 and C2 Values		
Crystal Frequency	C1	C2
12MHz	0pF	0pF
8MHz	0pF	0pF
4MHz	0pF	0pF
1MHz	100pF	100pF

Note: C1 and C2 values are for guidance only.

Crystal Recommended Capacitor Values

Internal RC Oscillator – HIRC

The internal RC oscillator is a fully integrated system oscillator requiring no external components. The internal RC oscillator has a fixed frequency of 8MHz. Device trimming during the manufacturing process and the inclusion of internal frequency compensation circuits are used to ensure that the influence of the power supply voltage, temperature and process variations on the oscillation frequency are minimised. As a result, at a power supply of 5V and at a temperature of -40°C ~85°C degrees, the fixed oscillation frequency of the high speed internal 8MHz RC oscillator will have a tolerance within 2%. Note that if this internal system clock option is selected as the high speed oscillator, as it requires no external pins for its operation, I/O pins PA6 and PA5 can only be used as normal I/O pins.

Internal 32kHz Oscillator – LIRC

The Internal 32kHz System Oscillator is the low frequency oscillator. It is a fully integrated RC oscillator with a typical frequency of 32kHz at 5V, requiring no external components for its implementation. Device trimming during the manufacturing process and the inclusion of internal frequency compensation circuits are used to ensure that the influence of the power supply voltage, temperature and process variations on the oscillation frequency are minimised. As a result, at a power supply of 5V and at a temperature of 25°C degrees, the fixed oscillation frequency of 32kHz will have a tolerance within 10%.

Supplementary Oscillators

The low speed oscillators, in addition to providing a system clock source are also used to provide a clock source to two other device functions. These are the Watchdog Timer and the Time Base Interrupts.

Operating Modes and System Clocks

Present day applications require that their microcontrollers have high performance but often still demand that they consume as little power as possible, conflicting requirements that are especially true in battery powered portable applications. The fast clocks required for high performance will by their nature increase current consumption and of course vice-versa, lower speed clocks reduce current consumption. As Holtek has provided these devices with both high and low speed clock sources and the means to switch between them dynamically, the user can optimise the operation of their microcontroller to achieve the best performance/power ratio.

System Clocks

The device has many different clock sources for both the CPU and peripheral function operation. By providing the user with a wide range of clock options using configuration options and register programming, a clock system can be configured to obtain maximum application performance.

The main system clock, can come from either a high frequency, f_H , or low frequency, f_L , source, and is selected using the HLCLK bit and CKS2~CKS0 bits in the SMOD register. The high speed system clock can be sourced from either an HXT or HIRC oscillator, selected via a configuration option. The low speed system clock source can be sourced from internal clock f_L . The other choice, which is a divided version of the high speed system oscillator has a range of $f_H/2 \sim f_H/64$.

There are two additional internal clocks for the peripheral circuits, the substitute clock, f_{SUB} , and the Time Base clock, f_{TBC} . Each of these internal clocks are sourced by the LIRC oscillators. The f_{SUB} clock is used to provide a substitute clock for the microcontroller just after a wake-up has occurred to enable faster wake-up times.

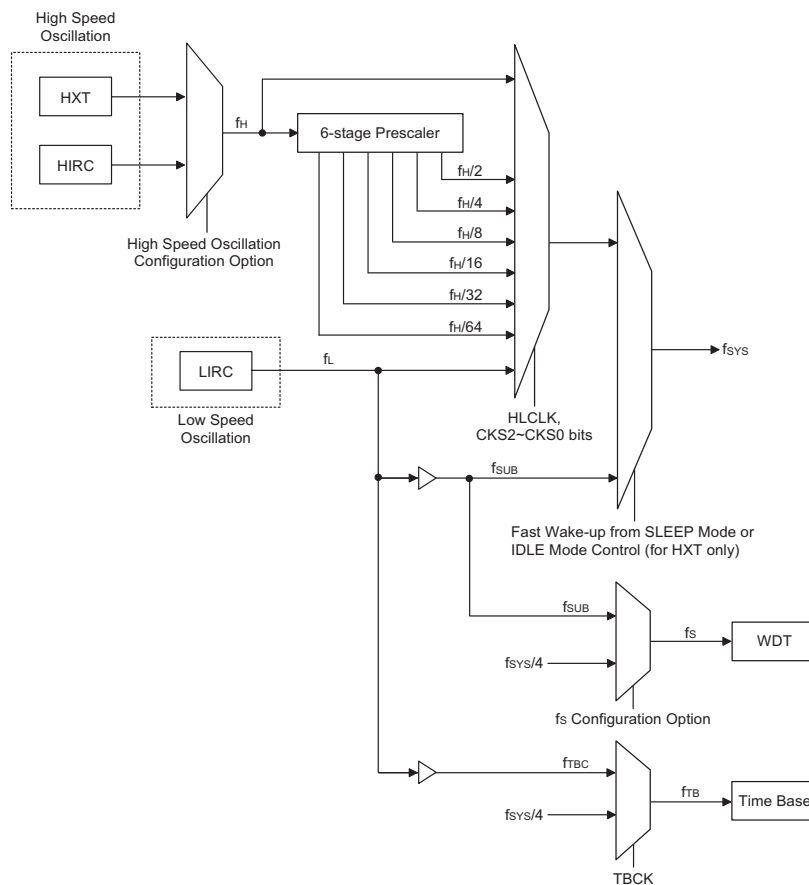

System Clock Configurations

Note: When the system clock source f_{SYS} is switched to f_L from f_H , the high speed oscillation will stop to conserve the power. Thus there is no $f_H \sim f_H/64$ for peripheral circuit to use.

Together with $f_{SYS}/4$ it is also used as one of the clock sources for the Watchdog timer. The f_{TBC} clock is used as a source for the Time Base interrupt functions and for the TMs.

System Operation Modes

There are six different modes of operation for the microcontroller, each one with its own special character-

istics and which can be chosen according to the specific performance and power requirements of the application. There are two modes allowing normal operation of the microcontroller, the NORMAL Mode and SLOW Mode. The remaining four modes, the SLEEP0, SLEEP1, IDLE0 and IDLE1 Mode are used when the microcontroller CPU is switched off to conserve power.

Operation Mode	Description				
	CPU	f_{SYS}	f_{SUB}	f_s	f_{TBC}
NORMAL Mode	On	$f_H \sim f_H/64$	On	On	On
SLOW Mode	On	f_L	On	On	On
IDLE0 Mode	Off	Off	On	On	On
IDLE1 Mode	Off	On	On	On	On
SLEEP0 Mode	Off	Off	Off	Off	Off
SLEEP1 Mode	Off	Off	On	On	Off

- **NORMAL Mode**

As the name suggests this is one of the main operating modes where the microcontroller has all of its functions operational and where the system clock is provided by one of the high speed oscillators. This mode operates allowing the microcontroller to operate normally with a clock source will come from one of the high speed oscillators, either the HXT or HIRC oscillators. The high speed oscillator will however first be divided by a ratio ranging from 1 to 64, the actual ratio being selected by the CKS2~LCKS0 and HLCLK bits in the SMOD register. Although a high speed oscillator is used, running the microcontroller at a divided clock ratio reduces the operating current.

- **SLOW Mode**

This is also a mode where the microcontroller operates normally although now with a slower speed clock source. The clock source used will be from the low speed oscillators LIRC. Running the microcontroller in this mode allows it to run with much lower operating currents. In the SLOW Mode, the f_H is off.

- **SLEEP0 Mode**

The SLEEP Mode is entered when an HALT instruction is executed and when the IDLEN bit in the SMOD register is low. In the SLEEP0 mode the CPU will be stopped, and the f_{SUB} and f_s clocks will be stopped too, and the Watchdog Timer function is disabled. In this mode, the LVDEN is must set to "0". If the LVDEN is set to "1", it won't enter the SLEEP0 Mode.

- **SLEEP1 Mode**

The SLEEP Mode is entered when an HALT instruction is executed and when the IDLEN bit in the SMOD register is low. In the SLEEP1 mode the CPU will be stopped. However the f_{SUB} and f_s clocks will continue to operate if the LVDEN is "1" or the Watchdog Timer function is enabled and if its clock source is chosen via configuration option to come from the f_{SUB} .

- **IDLE0 Mode**

The IDLE0 Mode is entered when a HALT instruction is executed and when the IDLEN bit in the SMOD register is high and the FSYSOEN bit in the CTRL register is low. In the IDLE0 Mode the system oscillator will be inhibited from driving the CPU but some peripheral functions will remain operational such as the Watchdog Timer and TMs. In the IDLE0 Mode, the system oscillator will be stopped.

- **IDLE1 Mode**

The IDLE1 Mode is entered when a HALT instruction is executed and when the IDLEN bit in the SMOD register is high and the FSYSOEN bit in the CTRL register is high. In the IDLE1 Mode the system oscillator will be inhibited from driving the CPU but may continue to provide a clock source to keep some peripheral functions operational such as the Watchdog Timer and TMs. In the IDLE1 Mode, the system oscillator will continue to run, and this system oscillator may be high speed or low speed system oscillator.

Control Register

A single register, SMOD, is used for overall control of the internal clocks within the device.

• SMOD Register

Bit	7	6	5	4	3	2	1	0
Name	CKS2	CKS1	CKS0	FSTEN	LTO	HTO	IDLEN	HLCLK
R/W	R/W	R/W	R/W	R/W	R	R	R/W	R/W
POR	0	0	0	0	0	0	1	1

Bit 7~5 **CKS2~CKS0:** The system clock selection when HLCLK is "0"

000: f_L (f_{LIRC})
 001: f_L (f_{LIRC})
 010: $f_H/64$
 011: $f_H/32$
 100: $f_H/16$
 101: $f_H/8$
 110: $f_H/4$
 111: $f_H/2$

These three bits are used to select which clock is used as the system clock source. In addition to the system clock source, which can be the LIRC, a divided version of the high speed system oscillator can also be chosen as the system clock source.

Bit 4 **FSTEN:** Fast Wake-up Control (only for HXT)

0: Disable
 1: Enable

This is the Fast Wake-up Control bit which determines if the f_{SUB} clock source is initially used after the device wakes up. When the bit is high, the f_{SUB} clock source can be used as a temporary system clock to provide a faster wake up time as the f_{SUB} clock is available.

Bit 3 **LTO:** Low speed system oscillator ready flag

0: Not ready
 1: Ready

This is the low speed system oscillator ready flag which indicates when the low speed system oscillator is stable after power on reset or a wake-up has occurred. The flag will be low when in the SLEEP0 Mode but after a wake-up has occurred, the flag will change to a high level after 1~2 clock cycles for the LIRC oscillator.

Bit 2 **HTO:** High speed system oscillator ready flag

0: Not ready
 1: Ready

This is the high speed system oscillator ready flag which indicates when the high speed system oscillator is stable. This flag is cleared to "0" by hardware when the device is powered on and then changes to a high level after the high speed system oscillator is stable. Therefore this flag will always be read as "1" by the application program after device power-on. The flag will be low when in the SLEEP or IDLE0 Mode but after a wake-up has occurred, the flag will change to a high level after 128 clock cycles if the HXT oscillator is used and after 15~16 clock cycles if the HIRC oscillator is used.

Bit 1 **IDLEN:** IDLE Mode control

0: Disable
 1: Enable

This is the IDLE Mode Control bit and determines what happens when the HALT instruction is executed. If this bit is high, when a HALT instruction is executed the device will enter the IDLE Mode. In the IDLE1 Mode the CPU will stop running but the system clock will continue to keep the peripheral functions operational, if FSYSN bit is high. If FSYSN bit is low, the CPU and the system clock will all stop in IDLE0 mode. If the bit is low the device will enter the SLEEP Mode when a HALT instruction is executed.

Bit 0 **HLCLK:** system clock selection

0: $f_H/2 \sim f_H/64$ or f_L
 1: f_H

This bit is used to select if the f_H clock or the $f_H/2 \sim f_H/64$ or f_L clock is used as the system clock. When the bit is high the f_H clock will be selected and if low the $f_H/2 \sim f_H/64$ or f_L clock will be selected. When system clock switches from the f_H clock to the f_L clock and the f_H clock will be automatically switched off to conserve power.

Fast Wake-up

To minimise power consumption the device can enter the SLEEP or IDLE0 Mode, where the system clock source to the device will be stopped. However when the device is woken up again, it can take a considerable time for the original system oscillator to restart, stabilise and allow normal operation to resume. To ensure the device is up and running as fast as possible a Fast Wake-up function is provided, which allows f_{SUB} , namely the LIRC oscillator, to act as a temporary clock to first drive the system until the original system oscillator has stabilised. As the clock source for the Fast Wake-up function is f_{SUB} , the Fast Wake-up function is only available in the SLEEP1 and IDLE0 modes. When the device is woken up from the SLEEP0 mode, the Fast Wake-up function has no effect because the f_{SUB} clock

is stopped. The Fast Wake-up enable/disable function is controlled using the FSTEN bit in the SMOD register.

If the HXT oscillator is selected as the NORMAL Mode system clock, and if the Fast Wake-up function is enabled, then it will take one to two t_{SUB} clock cycles of the LIRC oscillator for the system to wake-up. The system will then initially run under the f_{SUB} clock source until 128 HXT clock cycles have elapsed, at which point the HTO flag will switch high and the system will switch over to operating from the HXT oscillator.

If the HIRC oscillators or LIRC oscillator is used as the system oscillator then it will take 15~16 clock cycles of the HIRC or 1~2 cycles of the LIRC to wake up the system from the SLEEP or IDLE0 Mode. The Fast Wake-up bit, FSTEN will have no effect in these cases.

System Oscillator	FSTEN Bit	Wake-up Time (SLEEP0 Mode)	Wake-up Time (SLEEP1 Mode)	Wake-up Time (IDLE0 Mode)	Wake-up Time (IDLE1 Mode)
HXT	0	128 HXT cycles	128 HXT cycles	128 HXT cycles	1~2 HXT cycles
	1	128 HXT cycles	1~2 f_{SUB} cycles (System runs with f_{SUB} first for 128 HXT cycles and then switches over to run with the HXT clock)	1~2 f_{SUB} cycles	1~2 HXT cycles
HIRC	X	15~16 HIRC cycles	15~16 HIRC cycles	15~16 HIRC cycles	1~2 HIRC cycles
LIRC	X	1~2 LIRC cycles	1~2 LIRC cycles	1~2 LIRC cycles	1~2 LIRC cycles

Wake-Up Times

Note that if the Watchdog Timer is disabled, which means that the LIRC is off, then there will be no Fast Wake-up function available when the device wakes-up from the SLEEP0 Mode.

"X": don't care

Operating Mode Switching and Wake-up

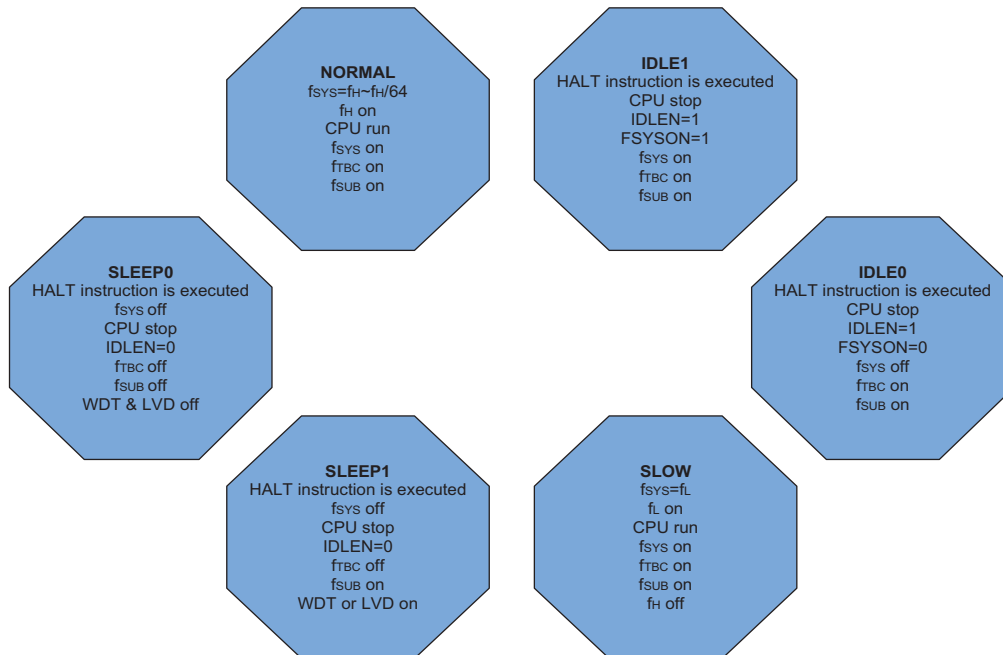

The device can switch between operating modes dynamically allowing the user to select the best performance/power ratio for the present task in hand. In this way microcontroller operations that do not require high performance can be executed using slower clocks thus requiring less operating current and prolonging battery life in portable applications.

In simple terms, Mode Switching between the NORMAL Mode and SLOW Mode is executed using the HLCLK bit and CKS2~CKS0 bits in the SMOD register while Mode Switching from the NORMAL/SLOW Modes to the SLEEP/IDLE Modes is executed via the HALT instruction. When a HALT instruction is executed, whether the device enters the IDLE Mode or the SLEEP Mode is determined by the condition of the IDLEN bit in the SMOD register and FSYSON in the CTRL register.

When the HLCLK bit switches to a low level, which implies that clock source is switched from the high speed clock source, f_H , to the clock source, $f_H/2 \sim f_H/64$ or f_L . If the clock is from the f_L , the high speed clock source will stop running to conserve power. When this happens it must be noted that the $f_H/16$ and $f_H/64$ internal clock

sources will also stop running, which may affect the operation of other internal functions such as the TMs. The accompanying flowchart shows what happens when the device moves between the various operating modes.

NORMAL Mode to SLOW Mode Switching

When running in the NORMAL Mode, which uses the high speed system oscillator, and therefore consumes more power, the system clock can switch to run in the SLOW Mode by setting the HLCLK bit to "0" and setting the CKS2~CKS0 bits to "000" or "001" in the SMOD register. This will then use the low speed system oscillator which will consume less power. Users may decide to do this for certain operations which do not require high performance and can subsequently reduce power consumption.

The SLOW Mode is sourced from the the LIRC oscillators and therefore requires these oscillators to be stable before full mode switching occurs. This is monitored using the LTO bit in the SMOD register.

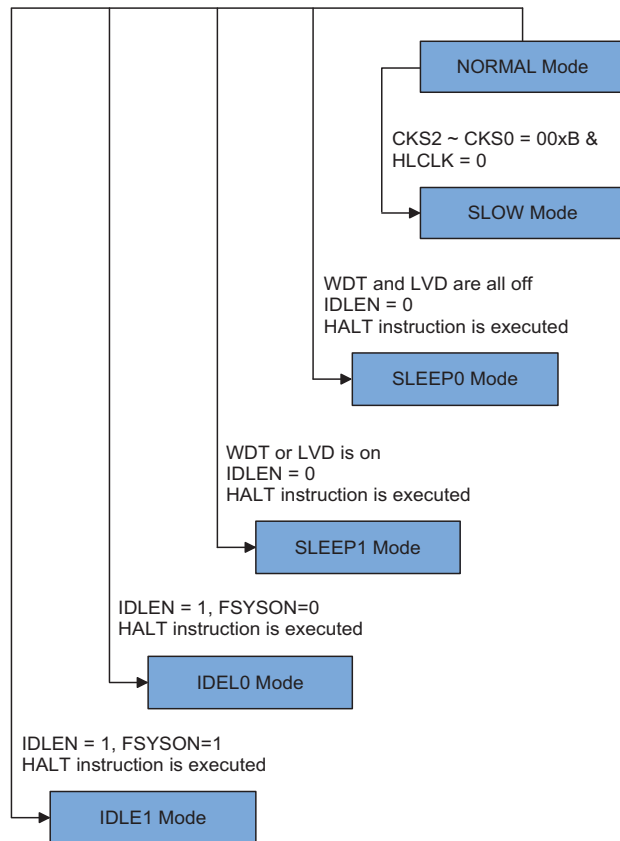

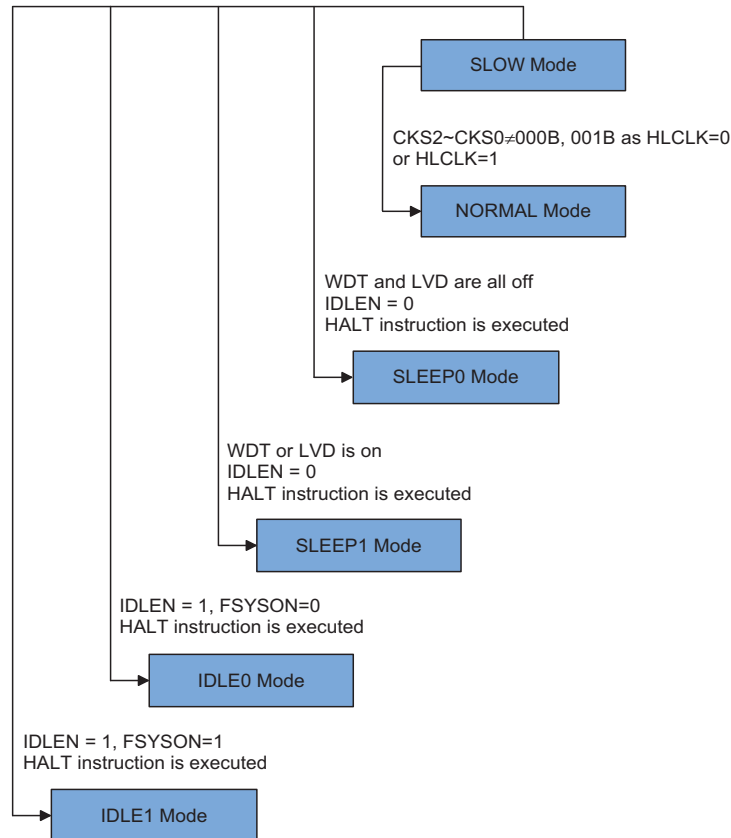

SLOW Mode to NORMAL Mode Switching

In SLOW Mode the system uses the LIRC low speed system oscillator. To switch back to the NORMAL Mode, where the high speed system oscillator is used, the HLCLK bit should be set to "1" or HLCLK bit is "0", but CKS2~CKS0 is set to "010", "011", "100", "101", "110" or "111". As a certain amount of time will be required for the high frequency clock to stabilise, the status of the HTO bit is checked. The amount of time required for high speed system oscillator stabilization depends upon which high speed system oscillator type is used.

Entering the SLEEP0 Mode

There is only one way for the device to enter the SLEEP0 Mode and that is to execute the "HALT" instruction in the application program with the IDLEN bit in SMOD register equal to "0" and the WDT and LVD both off. When this instruction is executed under the conditions described above, the following will occur:

- The system clock, WDT clock and Time Base clock will be stopped and the application program will stop at the "HALT" instruction.
- The Data Memory contents and registers will maintain their present condition.
- The WDT will be cleared and stopped no matter if the WDT clock source originates from the f_{SUB} clock or from the system clock.
- The I/O ports will maintain their present conditions.
- In the status register, the Power Down flag, PDF, will be set and the Watchdog time-out flag, TO, will be cleared.

Entering the SLEEP1 Mode

There is only one way for the device to enter the SLEEP1 Mode and that is to execute the "HALT" instruction in the application program with the IDLEN bit in SMOD register equal to "0" and the WDT or LVD on. When this instruction is executed under the conditions described above, the following will occur:

- The system clock and Time Base clock will be stopped and the application program will stop at the "HALT" instruction, but the WDT or LVD will remain with the clock source coming from the f_{SUB} clock.
- The Data Memory contents and registers will maintain their present condition.
- The WDT will be cleared and resume counting if the WDT is enabled.
- The I/O ports will maintain their present conditions.
- In the status register, the Power Down flag, PDF, will be set and the Watchdog time-out flag, TO, will be cleared.

Entering the IDLE0 Mode

There is only one way for the device to enter the IDLE0 Mode and that is to execute the "HALT" instruction in the application program with the IDLEN bit in SMOD register equal to "1" and the FSYSN bit in CTRL register equal to "0". When this instruction is executed under the conditions described above, the following will occur:

- The system clock will be stopped and the application program will stop at the "HALT" instruction, but the Time Base clock and f_{SUB} clock will be on.
- The Data Memory contents and registers will maintain their present condition.
- The WDT will be cleared and resume counting if the WDT is enabled.
- The I/O ports will maintain their present conditions.
- In the status register, the Power Down flag, PDF, will be set and the Watchdog time-out flag, TO, will be cleared.

Entering the IDLE1 Mode

There is only one way for the device to enter the IDLE1 Mode and that is to execute the "HALT" instruction in the application program with the IDLEN bit in SMOD register equal to "1" and the FSYSN bit in CTRL register equal to "1". When this instruction is executed under the conditions described above, the following will occur:

- The system clock and Time Base clock and f_{SUB} clock will be on and the application program will stop at the "HALT" instruction.
- The Data Memory contents and registers will maintain their present condition.
- The WDT will be cleared and resume counting if the WDT is enabled.
- The I/O ports will maintain their present conditions.
- In the status register, the Power Down flag, PDF, will be set and the Watchdog time-out flag, TO, will be cleared.

Standby Current Considerations

As the main reason for entering the SLEEP or IDLE Mode is to keep the current consumption of the device to as low a value as possible, perhaps only in the order of several micro-amps except in the IDLE1 Mode, there are other considerations which must also be taken into account by the circuit designer if the power consumption is to be minimised. Special attention must be made to the I/O pins on the device. All high-impedance input pins must be connected to either a fixed high or low level as any floating input pins could create internal oscillations and result in increased current consumption. This also applies to devices which have different package types, as there may be unbonded pins. These must either be setup as outputs or if setup as inputs must have pull-high resistors connected.

Care must also be taken with the loads, which are connected to I/O pins, which are setup as outputs. These should be placed in a condition in which minimum current is drawn or connected only to external circuits that do not draw current, such as other CMOS inputs. Also note that additional standby current will also be required if the configuration options have enabled the LIRC oscillator.

In the IDLE1 Mode the system oscillator is on, if the system oscillator is from the high speed system oscillator, the additional standby current will also be perhaps in the order of several hundred micro-amps.

Wake-up

After the system enters the SLEEP or IDLE Mode, it can be woken up from one of various sources listed as follows:

- An external reset
- An external falling edge on Port A
- A system interrupt
- A WDT overflow

If the system is woken up by an external reset, the device will experience a full system reset, however, if the device is woken up by a WDT overflow, a Watchdog Timer reset will be initiated. Although both of these wake-up methods will initiate a reset operation, the actual source of the wake-up can be determined by examining the TO and PDF flags. The PDF flag is cleared by a system power-up or executing the clear Watchdog Timer instructions and is set when executing the "HALT" instruction. The TO flag is set if a WDT time-out occurs, and causes a wake-up that only resets the Program Counter and Stack Pointer, the other flags remain in their original status.

Each pin on Port A can be setup using the PAWU register to permit a negative transition on the pin to wake-up the system. When a Port A pin wake-up occurs, the program will resume execution at the instruction following the "HALT" instruction. If the system is woken up by an interrupt, then two possible situations may occur. The first is where the related interrupt is disabled or the interrupt is enabled but the stack is full, in which case the program will resume execution at the instruction following the "HALT" instruction. In this situation, the interrupt which woke-up the device will not be immediately serviced, but will rather be serviced later when the related interrupt is finally enabled or when a stack level becomes free. The other situation is where the related interrupt is enabled and the stack is not full, in which case the regular interrupt response takes place. If an interrupt request flag is set high before entering the SLEEP or IDLE Mode, the wake-up function of the related interrupt will be disabled.

Programming Considerations

The high speed and low speed oscillators both use the same SST counter. For example, if the system is woken up from the SLEEP0 Mode and both the HIRC and LIRC oscillators need to start-up from an off state. The LIRC oscillator uses the SST counter after HIRC oscillator has finished its SST period.

- If the device is woken up from the SLEEP0 Mode to the NORMAL Mode, the high speed system oscillator needs an SST period. The device will execute first instruction after HTO is "1". At this time, the LIRC oscillator may not be stability. The same situation occurs in the power-on state. The LIRC oscillator is not ready yet when the first instruction is executed.
- If the device is woken up from the SLEEP1 Mode to NORMAL Mode, and the system clock source is from HXT oscillator and FSTEN is "1", the system clock can be switched to the LIRC oscillator after wake up.
- There are peripheral functions, such as WDT and TMs, for which the f_{SYS} is used. If the system clock source is switched from f_H to f_L , the clock source to the peripheral functions mentioned above will change accordingly.
- The on/off condition of f_{SUB} and f_S depends upon whether the WDT is enabled or disabled.

Watchdog Timer

The Watchdog Timer is provided to prevent program malfunctions or sequences from jumping to unknown locations, due to certain uncontrollable external events such as electrical noise.

Watchdog Timer Clock Source

The Watchdog Timer clock source is provided by the internal clock, f_s , which is in turn supplied by the LIRC oscillator. The LIRC internal oscillator has an approximate period of 32 kHz at a supply voltage of 5V. However, it should be noted that this specified internal clock period can vary with VDD, temperature and process variations. The Watchdog Timer source clock is then subdivided by a ratio of 2^8 to 2^{18} to give longer timeouts, the actual value being chosen using the WS2~WS0 bits in the WDTC register.

Watchdog Timer Control Register

A single register, WDTC, controls the required timeout period as well as the enable/disable operation. This register together with several configuration options control the overall operation of the Watchdog Timer.

Watchdog Timer Operation

The Watchdog Timer operates by providing a device reset when its timer overflows. This means that in the application program and during normal operation the user has to strategically clear the Watchdog Timer before it overflows to prevent the Watchdog Timer from executing a reset. This is done using the clear watchdog instructions. If the program malfunctions for whatever reason, jumps to an unknown location, or enters an endless loop, these clear instructions will not be executed in the correct manner, in which case the Watchdog Timer will overflow and reset the device. Some of the Watchdog Timer options, such as always on select and clear instruction type are selected using configuration options. With regard to the Watchdog Timer enable/disable function, there are also five bits, WE4~WE0, in the WDTC register to offer additional enable/disable and reset control of the Watchdog Timer. If the WDT configuration option is determined that the WDT function is always enabled, the WE4~WE0 bits still have effects on

the WDT function. When the WE4~WE0 bits value is equal to 01010B or 10101B, the WDT function is enabled. However, if the WE4~WE0 bits are changed to any other values except 01010B and 10101B, which is caused by the environmental noise or software setting, it will reset the microcontroller after 2~3 LIRC clock cycles. If the WDT configuration option is determined that the WDT function is controlled by the WDT control register, the WE4~WE0 values can determine which mode the WDT operates in. The WDT function will be disabled when the WE4~WE0 bits are set to a value of 10101B. The WDT function will be enabled if the WE4~WE0 bits value is equal to 01010B. If the WE4~WE0 bits are set to any other values by the environmental noise or software setting, except 01010B and 10101B, it will reset the device after 2~3 LIRC clock cycles. After power on these bits will have the value of 01010B.

Watchdog Timer Enable/Disable Control

WDT Configuration Option	WE4~WE0 Bits	WDT Function
Always Enable	01010B or 10101B	Enable
	Any other value	Reset MCU
Controlled by WDT Control Register	10101B	Disable
	01010B	Enable
	Any other value	Reset MCU

Under normal program operation, a Watchdog Timer time-out will initialise a device reset and set the status bit TO. However, if the system is in the SLEEP or IDLE Mode, when a Watchdog Timer time-out occurs, the TO bit in the status register will be set and only the Program Counter and Stack Pointer will be reset. Three methods can be adopted to clear the contents of the Watchdog Timer. The first is a WDT reset, which means a certain value except 01010B and 10101B written into the WE4~WE0 bit field, the second is using the Watchdog Timer software clear instructions and the third is via a HALT instruction.

There is only one method of using software instruction to clear the Watchdog Timer. That is to use the single "CLR WDT" instruction to clear the WDT.

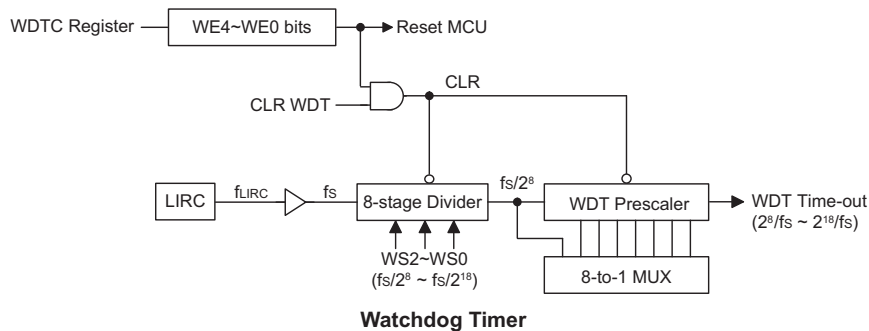

The maximum time out period is when the 2¹⁸ division ratio is selected. As an example, with a 32 kHz LIRC oscillator as its source clock, this will give a maximum

watchdog period of around 8 second for the 2¹⁸ division ratio, and a minimum timeout of 7.8ms for the 2⁸ division ratio.

• **WDTC Register**

Bit	7	6	5	4	3	2	1	0
Name	WE4	WE3	WE2	WE1	WE0	WS2	WS1	WS0
R/W	R/W	R/W	R/W	R/W	R/W	R/W	R/W	R/W
POR	0	1	0	1	0	0	1	1

Bit 7~3 **WE4~WE0**: WDT function software control
 If the WDT configuration option is "always enable":
 10101 or 01010: Enabled
 Other: Reset MCU
 If the WDT configuration option is "controlled by the WDT control register":
 10101: Disabled
 01010: Enabled
 Other: Reset MCU
 When these bits are changed by the environmental noise or software setting to reset the microcontroller, the reset operation will be activated after 2~3 LIRC clock cycles and the WRF bit in the CTRL register will be set to 1.

Bit 2~0 **WS2, WS1, WS0**: WDT time-out period selection
 000: 2⁸/f_S
 001: 2¹⁰/f_S
 010: 2¹²/f_S
 011: 2¹⁴/f_S
 100: 2¹⁵/f_S
 101: 2¹⁶/f_S
 110: 2¹⁷/f_S
 111: 2¹⁸/f_S

• **CTRL Register**

Bit	7	6	5	4	3	2	1	0
Name	FSYSON	—	—	—	—	LVRF	LRF	WRF
R/W	R/W	—	—	—	—	R/W	R/W	R/W
POR	0	—	—	—	—	x	0	0

"x" unknown

Bit 7 **FSYSON**: f_{sys} Control in IDLE Mode
 0: Disable
 1: Enable

Bit 6~3 Unimplemented, read as "0"

Bit 2 **LVRF**: LVR function reset flag
 0: Not occur
 1: Occurred
 This bit is set to 1 when a specific Low Voltage Reset situation condition occurs. This bit can only be cleared to 0 by the application program.

Bit 1 **LRF**: LVR Control register software reset flag
 0: Not occur
 1: Occurred
 This bit is set to 1 if the LVRC register contains any non defined LVR voltage register values. This in effect acts like a software reset function. This bit can only be cleared to 0 by the application program.

Bit 0 **WRF**: WDT Control register software reset flag
 0: Not occur
 1: Occurred
 This bit is set to 1 by the WDT Control register software reset and cleared by the application program. Note that this bit can only be cleared to 0 by the application program.

Reset and Initialisation

A reset function is a fundamental part of any microcontroller ensuring that the device can be set to some predetermined condition irrespective of outside parameters. The most important reset condition is after power is first applied to the microcontroller. In this case, internal circuitry will ensure that the microcontroller, after a short delay, will be in a well defined state and ready to execute the first program instruction. After this power-on reset, certain important internal registers will be set to defined states before the program commences. One of these registers is the Program Counter, which will be reset to zero forcing the microcontroller to begin program execution from the lowest Program Memory address.

Another type of reset is when the Watchdog Timer overflows and resets the microcontroller. All types of reset operations result in different register conditions being setup. Another reset exists in the form of a Low Voltage Reset, LVR, where a full reset is implemented in situations where the power supply voltage falls below a certain threshold.

Reset Functions

There are five ways in which a microcontroller reset can occur, through events occurring both internally and externally:

- Power-on Reset

The most fundamental and unavoidable reset is the one that occurs after power is first applied to the microcontroller. As well as ensuring that the Program Memory begins execution from the first memory address, a power-on reset also ensures that certain other registers are preset to known conditions. All the I/O port and port control registers will power up in a high condition ensuring that all pins will be first set to inputs.

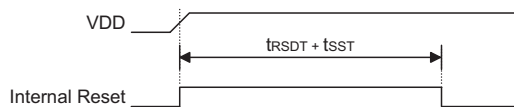

Note: t_{RSTD} is power-on delay, typical time=50ms

Power-On Reset Timing Chart

- \overline{RES} Pin

As the reset pin is shared with PA.7, the reset function must be selected using a configuration option. Although the microcontroller has an internal RC reset function, if the VDD power supply rise time is not fast enough or does not stabilise quickly at power-on, the internal reset function may be incapable of providing proper reset operation. For this reason it is recommended that an external RC network is connected to the \overline{RES} pin, whose additional time delay will ensure that the \overline{RES} pin remains low for an extended period to allow the power supply to stabilise. During this time delay, normal operation of the microcontroller will be

inhibited. After the \overline{RES} line reaches a certain voltage value, the reset delay time t_{RSTD} is invoked to provide an extra delay time after which the microcontroller will begin normal operation. The abbreviation SST in the figures stands for System Start-up Timer.

For most applications a resistor connected between VDD and the \overline{RES} pin and a capacitor connected between VSS and the \overline{RES} pin will provide a suitable external reset circuit. Any wiring connected to the \overline{RES} pin should be kept as short as possible to minimise any stray noise interference.

For applications that operate within an environment where more noise is present the Enhanced Reset Circuit shown is recommended.

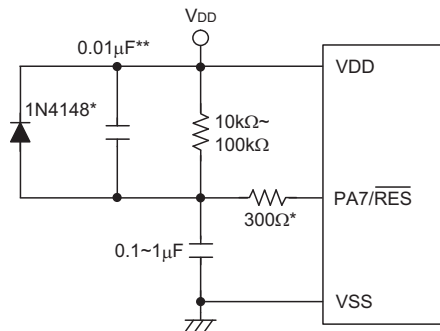

Note: "*" It is recommended that this component is added for added ESD protection

"**" It is recommended that this component is added in environments where power line noise is significant

External \overline{RES} Circuit

More information regarding external reset circuits is located in Application Note HA0075E on the Holtek website.

Pulling the \overline{RES} Pin low using external hardware will also execute a device reset. In this case, as in the case of other resets, the Program Counter will reset to zero and program execution initiated from this point.

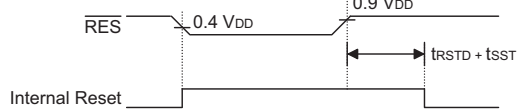

Note: t_{RSTD} is power-on delay, typical time=100ms

\overline{RES} Reset Timing Chart

- Low Voltage Reset – LVR

The microcontroller contains a low voltage reset circuit in order to monitor the supply voltage of the device. The LVR function is always enabled with a specific LVR voltage V_{LVR} . If the supply voltage of the device drops to within a range of $0.9V - V_{LVR}$ such as might occur when changing the battery, the LVR will automatically reset the device internally and the LVRF bit in the CTRL register will also be set to 1. For a valid LVR signal, a low supply voltage, i.e., a voltage in the

range between $0.9V \sim V_{LVR}$ must exist for a time greater than that specified by t_{LVR} in the A.C. characteristics. If the low supply voltage state does not exceed this value, the LVR will ignore the low supply voltage and will not perform a reset function. The actual V_{LVR} value can be selected by the LVS bits in the LVRC register. If the LVST7~LVST0 bits are changed to some certain values by the environmental noise or software setting, the LVR will reset the device after 2~3 LIRC clock cycles. When this happens, the LRF bit in the CTRL register will be set to 1. After power on the register will have the value of 01010101B. Note that the LVR function will be automatically disabled when the device enters the power down mode.

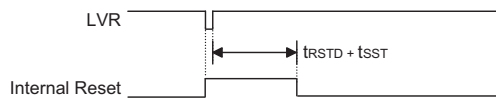

Note: t_{RSTD} is power-on delay, typical time=16.7ms

Low Voltage Reset Timing Chart

- Watchdog Time-out Reset during Normal Operation
The Watchdog time-out Reset during normal operation is the same as LVR reset except that the Watchdog time-out flag TO will be set to "1".

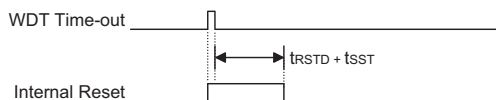

Note: t_{RSTD} is power-on delay, typical time=50ms

WDT Time-out Reset during Normal Operation Timing Chart

- Watchdog Time-out Reset during SLEEP or IDLE Mode
The Watchdog time-out Reset during SLEEP or IDLE Mode is a little different from other kinds of reset. Most of the conditions remain unchanged except that the Program Counter and the Stack Pointer will be cleared to "0" and the TO flag will be set to "1". Refer to the A.C. Characteristics for t_{SST} details.

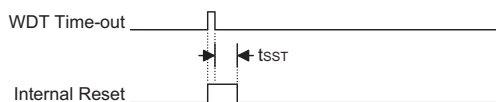

WDT Time-out Reset during SLEEP or IDLE Timing Chart

Note: The t_{SST} is 15~16 clock cycles if the system clock source is provided by HIRC. The t_{SST} is 128 clock for HXT. The t_{SST} is 1~2 clock for LIRC.

Reset Initial Conditions

The different types of reset described affect the reset flags in different ways. These flags, known as PDF and TO are located in the status register and are controlled by various microcontroller operations, such as the SLEEP or IDLE Mode function or Watchdog Timer. The reset flags are shown in the table:

TO	PDF	RESET Conditions
0	0	Power-on reset
u	u	RES or LVR reset during NORMAL or SLOW Mode operation
1	u	WDT time-out reset during NORMAL or SLOW Mode operation
1	1	WDT time-out reset during IDLE or SLEEP Mode operation

Note: "u" stands for unchanged.

The following table indicates the way in which the various components of the microcontroller are affected after a power-on reset occurs.

Item	Condition After RESET
Program Counter	Reset to zero
Interrupts	All interrupts will be disabled
WDT	Clear after reset, WDT begins counting
Timer Modules	Timer Counter will be turned off
Input/Output Ports	I/O ports will be setup as inputs, and AN0~AN3 as A/D input pins
Stack Pointer	Stack Pointer will point to the top of the stack

• **LVRC Register**

Bit	7	6	5	4	3	2	1	0
Name	LVS7	LVS6	LVS5	LVS4	LVS3	LVS2	LVS1	LVS0
R/W	R/W	R/W	R/W	R/W	R/W	R/W	R/W	R/W
POR	0	1	0	1	0	0	1	1

Bit 7~0

LVS7~LVS0: LVR Voltage Select control

01010101: 2.1V

00110011: 2.55V

10011001: 3.15V

10101010: 3.8V

Any other value: Generates MCU reset -- LVRC register is reset to POR value

When an actual low voltage condition occurs, as specified by one of the four defined LVR voltage values above, an MCU reset will be generated. The reset operation will be activated after 2~3 LIRC clock cycles. In this situation the register contents will remain the same after such a reset occurs.

Any register value, other than the four defined LVR values above, will also result in the generation of an MCU reset. The reset operation will be activated after 2~3 LIRC clock cycles. However in this situation the register contents will be reset to the POR value.

The different kinds of resets all affect the internal registers of the microcontroller in different ways. To ensure reliable continuation of normal program execution after a reset occurs, it is important to know what condition the microcontroller is in after a particular reset occurs. The following table describes how each type of reset affects each of the microcontroller internal registers. Note that where more than one package type exists the table will reflect the situation for the larger package type.

Register	HT66F016	HT66F017	HT68F016	HT68F017	Reset (Power-on)	RES or LVR Reset	WDT Time-out (Normal Operation)	WDT Time-out (IDLE)
MP0	●	●	●	●	x x x x x x x x	x x x x x x x x	x x x x x x x x	u u u u u u u u
MP1	●	●	●	●	x x x x x x x x	x x x x x x x x	x x x x x x x x	u u u u u u u u
BP	●	●	●	●	-----0	-----0	-----0	-----u
ACC	●	●	●	●	x x x x x x x x	u u u u u u u u	u u u u u u u u	u u u u u u u u
PCL	●	●	●	●	0 0 0 0 0 0 0 0	0 0 0 0 0 0 0 0	0 0 0 0 0 0 0 0	0 0 0 0 0 0 0 0
TBLP	●	●	●	●	x x x x x x x x	u u u u u u u u	u u u u u u u u	u u u u u u u u
TBLH	●	●	●	●	x x x x x x x x	u u u u u u u u	u u u u u u u u	u u u u u u u u
TBHP		●	●		-----x x x	-----u u u	-----u u u	-----u u u
	●		●		-----x x	-----u u	-----u u	-----u u
STATUS	●	●	●	●	--00 x x x x	--u u u u u u	--1u u u u u	--11 u u u u
SMOD	●	●	●	●	0 0 0 0 0 0 1 1	0 0 0 0 0 0 1 1	0 0 0 0 0 0 1 1	u u u u u u u u
LVDC	●	●	●	●	--00 -000	--00 -000	--00 -000	--u u -u u u
INTEG	●	●	●	●	-----0000	-----0000	-----0000	-----u u u u
INTC0		●	●		-000 0000	-000 0000	-000 0000	-u u u u u u u u
	●		●		--00 -000	--00 -000	--00 -000	--u u -u u u
INTC1	●	●			0000 0000	0000 0000	0000 0000	u u u u u u u u
			●	●	0-00 0-00	0-00 0-00	0-00 0-00	u-u u u-u u
INTC2	●	●	●	●	--00 --00	--00 --00	--00 --00	--u u --u u
MFI0		●		●	--00 --00	--00 --00	--00 --00	--u u --u u
MFI1	●	●	●	●	--00 --00	--00 --00	--00 --00	--u u --u u
MFI2	●	●	●	●	--00 --00	--00 --00	--00 --00	--u u --u u
PA	●	●	●	●	1 1 1 1 1 1 1 1	1 1 1 1 1 1 1 1	1 1 1 1 1 1 1 1	u u u u u u u u

Register	HT66F016	HT66F017	HT68F016	HT68F017	Reset (Power-on)	RES or LVR Reset	WDT Time-out (Normal Operation)	WDT Time-out (IDLE)
PAC	●	●	●	●	1111 1111	1111 1111	1111 1111	uuuu uuuu
PAPU	●	●	●	●	0000 0000	0000 0000	0000 0000	uuuu uuuu
PAWU	●	●	●	●	0000 0000	0000 0000	0000 0000	uuuu uuuu
PB	●	●	●	●	--11 1111	--11 1111	--11 1111	--uu uuuu
PBC	●	●	●	●	--11 1111	--11 1111	--11 1111	--uu uuuu
PBPU	●	●	●	●	--00 0000	--00 0000	--00 0000	--uu uuuu
PRM	●	●	●	●	0101 0000	0101 0000	0101 0000	uuuu uuuu
TMPC		●		●	---- --00	---- --00	---- --00	---- --uu
	●		●		---- --0-	---- --0-	---- --0-	---- --u-
WDTC	●	●	●	●	0101 0011	0101 0011	0101 0011	uuuu uuuu
TBC	●	●	●	●	0011 -111	0011 -111	0011 -111	uuuu -uuu
EEA	●	●	●	●	--00 0000	--00 0000	--00 0000	--uu uuuu
EED	●	●	●	●	0000 0000	0000 0000	0000 0000	uuuu uuuu
EEC	●	●	●	●	---- 0000	---- 0000	---- 0000	---- uuuu
ADRL (ADRF5=0)	●	●			x xxx ----	x xxx ----	x xxx ----	uuuu ----
ADRL (ADRF5=1)	●	●			x xxx x xxx	x xxx x xxx	x xxx x xxx	uuuu uuuu
ADRH (ADRF5=0)	●	●			x xxx x xxx	x xxx x xxx	x xxx x xxx	uuuu uuuu
ADRH (ADRF5=1)	●	●			---- x xxx	---- x xxx	---- x xxx	---- uuuu
ADCR0	●	●			0110 --00	0110 --00	0110 --00	uuuu --uu
ADCR1	●	●			00-0 -000	00-0 -000	00-0 -000	uu-u -uuu
ACERL	●	●			---- 1111	---- 1111	---- 1111	---- uuuu
CPC	●	●	●	●	1000 0--1	1000 0--1	1000 0--1	uuuu u--u
CTRL	●	●	●	●	0--- -x00	u--- -uuu	u--- -uuu	u--- -uuu
LVRC	●	●	●	●	0101 0101	0101 0101	0101 0101	uuuu uuuu
TM0C0		●		●	0000 0---	0000 0---	0000 0---	uuuu u---
TM0C1		●		●	0000 0000	0000 0000	0000 0000	uuuu uuuu
TM0DL		●		●	0000 0000	0000 0000	0000 0000	uuuu uuuu
TM0DH		●		●	0000 0000	0000 0000	0000 0000	uuuu uuuu
TM0AL		●		●	0000 0000	0000 0000	0000 0000	uuuu uuuu
TM0AH		●		●	0000 0000	0000 0000	0000 0000	uuuu uuuu
TM0RP		●		●	0000 0000	0000 0000	0000 0000	uuuu uuuu
TM1C0	●	●	●	●	0000 0---	0000 0---	0000 0---	uuuu u---
TM1C1	●	●	●	●	0000 0000	0000 0000	0000 0000	uuuu uuuu
TM1DL	●	●	●	●	0000 0000	0000 0000	0000 0000	uuuu uuuu
TM1DH	●	●	●	●	0000 0000	0000 0000	0000 0000	uuuu uuuu
TM1AL	●	●	●	●	0000 0000	0000 0000	0000 0000	uuuu uuuu
TM1AH	●	●	●	●	0000 0000	0000 0000	0000 0000	uuuu uuuu
TM1RP	●	●	●	●	0000 0000	0000 0000	0000 0000	uuuu uuuu

Note: "u" stands for unchanged
"x" stands for unknown
"--" stands for unimplemented

Input/Output Ports

Holtek microcontrollers offer considerable flexibility on their I/O ports. With the input or output designation of every pin fully under user program control, pull-high selections for all ports and wake-up selections on certain pins, the user is provided with an I/O structure to meet the needs of a wide range of application possibilities.

The device provides bidirectional input/output lines labeled with port names PA and PB. These I/O ports are mapped to the RAM Data Memory with specific addresses as shown in the Special Purpose Data Memory table. All of these I/O ports can be used for input and output operations. For input operation, these ports are non-latching, which means the inputs must be ready at the T2 rising edge of instruction "MOV A,[m]", where m denotes the port address. For output operation, all the data is latched and remains unchanged until the output latch is rewritten.

• I/O Register List

Register Name	Bit							
	7	6	5	4	3	2	1	0
PA	D7	D6	D5	D4	D3	D2	D1	D0
PAC	D7	D6	D5	D4	D3	D2	D1	D0
PAPU	D7	D6	D5	D4	D3	D2	D1	D0
PAWU	D7	D6	D5	D4	D3	D2	D1	D0
PB	—	—	D5	D4	D3	D2	D1	D0
PBC	—	—	D5	D4	D3	D2	D1	D0
PBPU	—	—	D5	D4	D3	D2	D1	D0
PRM	PRML3	PRML2	PRML1	PRML0	PRMS3	PRMS2	PRMS1	PRMS0

Pull-High Resistors

Many product applications require pull-high resistors for their switch inputs usually requiring the use of an external resistor. To eliminate the need for these external resistors, all I/O pins, when configured as an input have the capability of being connected to an internal pull-high resistor. These pull-high resistors are selected using the register PAPU and PBPU, and are implemented using weak PMOS transistors.

• PAPU Register

Bit	7	6	5	4	3	2	1	0
Name	D7	D6	D5	D4	D3	D2	D1	D0
R/W	R/W	R/W	R/W	R/W	R/W	R/W	R/W	R/W
POR	0	0	0	0	0	0	0	0

Bit 7~0 I/O Port A bit 7 ~ bit 0 Pull-high control
 0: disable
 1: enable

• PBPU Register

Bit	7	6	5	4	3	2	1	0
Name	—	—	D5	D4	D3	D2	D1	D0
R/W	—	—	R/W	R/W	R/W	R/W	R/W	R/W
POR	—	—	0	0	0	0	0	0

Bit 7~6 "—" Unimplemented, read as 0
 Bit 5~0 I/O Port B bit 5 ~ bit 0 Pull-high control
 0: disable
 1: enable

Port A Wake-up

The HALT instruction forces the microcontroller into the SLEEP or IDLE Mode which preserves power, a feature that is important for battery and other low-power applications. Various methods exist to wake-up the microcontroller, one of which is to change the logic condition on one of the Port A pins from high to low. This function is especially suitable for applications that can be woken up via external switches. Each pin on Port A can be selected individually to have this wake-up feature using the PAWU register.

• PAWU Register

Bit	7	6	5	4	3	2	1	0
Name	D7	D6	D5	D4	D3	D2	D1	D0
R/W	R/W	R/W	R/W	R/W	R/W	R/W	R/W	R/W
POR	0	0	0	0	0	0	0	0

Bit 7~0 **PAWU:** Port A bit 7 ~ bit 0 wake-up control
 0: disable
 1: enable

I/O Port Control Register

The I/O port has its own control register known as PAC and PBC, to control the input/output configuration. With this control register, each CMOS output or input can be reconfigured dynamically under software control. Each pin of the I/O port is directly mapped to a bit in its associated port control register. For the I/O pin to function as an input, the corresponding bit of the control register must be written as a "1". This will then allow the logic state of the input pin to be directly read by instructions. When the corresponding bit of the control register is written as a "0", the I/O pin will be setup as a CMOS output. If the pin is currently setup as an output, instructions can still be used to read the output register. However, it should be noted that the program will in fact only read the status of the output data latch and not the actual logic status of the output pin.

• PAC Register

Bit	7	6	5	4	3	2	1	0
Name	D7	D6	D5	D4	D3	D2	D1	D0
R/W	R/W	R/W	R/W	R/W	R/W	R/W	R/W	R/W
POR	1	1	1	1	1	1	1	1

Bit 7~0 I/O Port A bit 7 ~ bit 0 input/output control
 0: Output
 1: Input

• PBC Register

Bit	7	6	5	4	3	2	1	0
Name	—	—	D5	D4	D3	D2	D1	D0
R/W	—	—	R/W	R/W	R/W	R/W	R/W	R/W
POR	—	—	1	1	1	1	1	1

Bit 7~6 "—" Unimplemented, read as 0
 Bit 5~0 I/O Port B bit 5 ~ bit 0 input/output control
 0: Output
 1: Input

Pin-remapping Functions

The flexibility of the microcontroller range is greatly enhanced by the use of pins that have more than one function. Limited numbers of pins can force serious design constraints on designers but by supplying pins with multi-functions, many of these difficulties can be overcome. The way in which the pin function of each pin is selected is different for each function and a priority order is established where more than one pin function is selected simultaneously. Additionally there is a PRM register to establish certain pin functions. Generally speaking, the analog function has higher priority than the digital function. However, if more than two analog functions are enabled and the analog signal input comes from the same external pin, the analog input will be internally connected to all of these active analog functional modules.

Pin-remapping Registers

The limited number of supplied pins in a package can impose restrictions on the amount of functions a certain device can contain. However by allowing the same pins to share several different functions and providing a means of function selection, a wide range of different functions can be incorporated into even relatively small package sizes.

• PRM Register

Bit	7	6	5	4	3	2	1	0
Name	PRML3	PRML2	PRML1	PRML0	PRMS3	PRMS2	PRMS1	PRMS0
R/W	R/W	R/W	R/W	R/W	R/W	R/W	R/W	R/W
POR	0	1	0	1	0	0	0	0

Bit 7~4 **PRML3~PRML0**: pin-remapping function lock bits (default: 0101)
 1010: PRM register write operation is enabled
 Others: PRM register write operation is disabled

Bit 3 **PRMS3**: INT1 pin-remapping function selection bit
 0: INT1 on PA5
 1: INT1 on PA4

Bit 2 **PRMS2**: INT0/TCK1 pin-remapping function selection bit
 0: INT0 on PA3, TCK1 on PA3
 1: INT0 on PA2, TCK1 on PA2

Bit 1~0 **PRMS1~PRMS0**: pin-remapping function selection bits
 For HT66F017, HT68F017
 0: TP0 on PA3, TP1/TCK0 on PA4
 1: TP0 on PB0, TP1/TCK0 on PB1
 2: TP0 on PA5, TP1/TCK0 on PA6
 3: TP0 on PA2, TP1/TCK0 on PA7
 For HT66F016, HT68F016
 0: TP1 on PA4
 1: TP1 on PB1
 2: TP1 on PA6
 3: TP1 on PA7

I/O Pin Structures

The accompanying diagrams illustrate the internal structures of some generic I/O pin types. As the exact logical construction of the I/O pin will differ from these drawings, they are supplied as a guide only to assist with the functional understanding of the I/O pins. The wide range of pin-shared structures does not permit all types to be shown.

Programming Considerations

Within the user program, one of the first things to consider is port initialisation. After a reset, all of the I/O data and port control registers will be set high. This means that all I/O pins will default to an input state, the level of which depends on the other connected circuitry and

whether pull-high selections have been chosen. If the port control registers, PAC and PBC, are then programmed to setup some pins as outputs, these output pins will have an initial high output value unless the associated port data registers, PA and PB, are first programmed. Selecting which pins are inputs and which are outputs can be achieved byte-wide by loading the correct values into the appropriate port control register or by programming individual bits in the port control register using the "SET [m].i" and "CLR [m].i" instructions. Note that when using these bit control instructions, a read-modify-write operation takes place. The microcontroller must first read in the data on the entire port, modify it to the required new bit values and then re-write this data back to the output ports.

Timer Modules – TM

One of the most fundamental functions in any microcontroller device is the ability to control and measure time. To implement time related functions each device includes several Timer Modules, abbreviated to the name TM. The TMs are multi-purpose timing units and serve to provide operations such as Timer/Counter, Input Capture, Compare Match Output and Single Pulse Output as well as being the functional unit for the generation of PWM signals. Each of the TMs has either two individual interrupts. The addition of input and output pins for each TM ensures that users are provided with timing units with a wide and flexible range of features.

The common features of the different TM types are described here with more detailed information provided in the individual Compact, Standard and Enhanced TM sections.

Introduction

The devices contain two TMs with each TM having a reference name of TM0 and TM1. Each individual TM can be categorised as a certain type, namely Compact Type TM (CTM) or Standard Type TM (STM). Although similar in nature, the different TM types vary in their feature complexity. The common features to all of the Compact and Standard TMs will be described in this section and the detailed operation regarding each of the TM types will be described in separate sections. The main features and differences between the two types of TMs are summarised in the accompanying table.

TM Operation

The two different types of TM offer a diverse range of functions, from simple timing operations to PWM signal generation. The key to understanding how the TM operates is to see it in terms of a free running counter whose value is then compared with the value of pre-programmed internal comparators. When the free running counter has the same value as the pre-programmed comparator, known as a compare match situation, a TM interrupt signal will be generated which can clear the counter and perhaps also change the condition of the TM output pin. The internal TM counter is driven by a user selectable clock source, which can be an internal clock or an external pin.

TM Clock Source

The clock source which drives the main counter in each TM can originate from various sources. The selection of the required clock source is implemented using the TnCK2~TnCK0 bits in the TM control registers. The clock source can be a ratio of either the system clock f_{SYS} or the internal high clock f_H , the f_{TBC} clock source or the external TCKn pin. Note that setting these bits to the value 101 will select a reserved clock input, in effect disconnecting the TM clock source. The TCKn pin clock source is used to allow an external signal to drive the TM as an external clock source or for event counting.

Function	CTM	STM
Timer/Counter	√	√
I/P Capture	—	√
Compare Match Output	√	√
PWM Channels	1	1
Single Pulse Output	—	1
PWM Alignment	Edge	Edge
PWM Adjustment Period & Duty	Duty or Period	Duty or Period

TM Function Summary

Each device in the series contains a Compact Type and/or Standard Type TM units which are shown in the table together with their individual reference name, TM0 and TM1.

Device	TM0	TM1
HT66F016, HT68F016	—	16-bit STM
HT66F017, HT68F017	16-bit CTM	16-bit STM

TM Name/Type Reference

TM Interrupts

The Compact and Standard type TMs each have two internal interrupts, one for each of the internal comparator A or comparator P, which generate a TM interrupt when a compare match condition occurs. When a TM interrupt is generated it can be used to clear the counter and also to change the state of the TM output pin.

TM External Pins

Each of the TMs, irrespective of what type, has one TM input pin, with the label TCKn. The TM input pin, is essentially a clock source for the TM and is selected using the TnCK2~TnCK0 bits in the TMnC0 register. This external TM input pin allows an external clock source to drive the internal TM. This external TM input pin is shared with other functions but will be connected to the internal TM if selected using the TnCK2~TnCK0 bits. The TM input pin can be chosen to have either a rising or falling active edge.

The TMs each have one output pin with the label TPn. When the TM is in the Compare Match Output Mode, these pins can be controlled by the TM to switch to a high or low level or to toggle when a compare match situation occurs. The external TPn output pin is also the pin where the TM generates the PWM output waveform. The TPn pin acts as an input when the TM is setup to operate in the Capture Input Mode. As the TPn pins are pin-shared with other functions, the TPn pin function is

enabled or disabled according to the internal TM on/off control, operation mode and output control settings. When the corresponding TM configuration selects the TPn pin to be used as an output pin, the associated pin will be setup as an external TM output pin. If the TM configuration selects the TPn pin to be setup as an input pin, the input signal supplied on the associated pin can be derived from an external signal and other pin-shared output function. If the TM configuration determines that the TPn pin function is not used, the associated pin will be controlled by other pin-shared functions. The details of the TPn pin for each TM type and device are provided in the accompanying table.

Device	CTM	STM	Registers
HT66F016 HT68F016	—	TP1	TMPC
HT66F017 HT68F017	TP0	TP1	TMPC

TM Output Pins

TM Input/Output Pin Control Registers

Selecting to have a TM input/output or whether to retain its other shared functions is implemented using one register with a single bit in each register corresponding to a TM input/output pin. Setting the bit high will setup the corresponding pin as a TM input/output if reset to zero the pin will retain its original other functions.

TMPC Register List

Device	Bit7	Bit6	Bit5	Bit4	Bit3	Bit2	Bit1	Bit0
HT66F016 HT68F016	—	—	—	—	—	—	T1CP	—
HT66F017 HT68F017	—	—	—	—	—	—	T1CP	T0CP

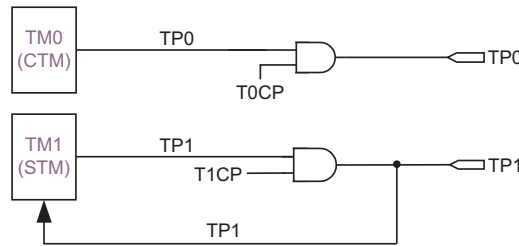

TM Function Pin Control Block Diagram

• **TMPC Register**

♦ HT66F016/HT68F016

Bit	7	6	5	4	3	2	1	0
Name	—	—	—	—	—	—	T1CP	—
R/W	—	—	—	—	—	—	R/W	—
POR	—	—	—	—	—	—	0	—

Bit 7~2 Unimplemented, read as "0"

Bit 1 **T1CP**: TP1 pin control
0: disable TP1 pin function
1: enable TP1 pin function

Bit 0 Unimplemented, read as "0"

♦ HT66F017/HT68F017

Bit	7	6	5	4	3	2	1	0
Name	—	—	—	—	—	—	T1CP	T0CP
R/W	—	—	—	—	—	—	R/W	R/W
POR	—	—	—	—	—	—	0	0

Bit 7~2 Unimplemented, read as "0"

Bit 1 **T1CP**: TP1 pin control
0: disable TP1 pin function
1: enable TP1 pin function

Bit 0 **T0CP**: TP0 Pin Control
0: Disable TP0 pin function
1: Enable TP0 pin function

Programming Considerations

The TM Counter Registers and the Capture/Compare CCRA registers, being 16-bit, all have a low and high byte structure. The high bytes can be directly accessed, but as the low bytes can only be accessed via an internal 8-bit buffer, reading or writing to these register pairs must be carried out in a specific way. The important point to note is that data transfer to and from the 8-bit buffer and its related low byte only takes place when a write or read operation to its corresponding high byte is executed. As the CCRA registers are implemented in the way shown in the following diagram and accessing these register pairs is carried out in a specific way described above, it is recommended to use the "MOV" instruction to access the CCRA low byte registers, named

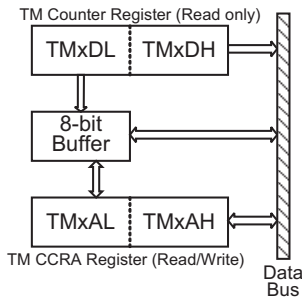

TMxAL, using the following access procedures. Accessing the CCRA low byte registers without following these access procedures will result in unpredictable values.

The following steps show the read and write procedures:

- Writing data to CCRA
 - ♦ Step 1. Write data to Low Byte TMxAL - note that here data is only written to the 8-bit buffer.
 - ♦ Step 2. Write data to High Byte TMxAH - here data is written directly to the high byte registers and simultaneously data is latched from the 8-bit buffer to the Low Byte registers.
- Reading Data from the Counter Registers and CCRA
 - ♦ Step 1. Read data from the High Byte TMxDH, TMxAH - here data is read directly from the High Byte registers and simultaneously data is latched from the Low Byte register into the 8-bit buffer.
 - ♦ Step 2. Read data from the Low Byte TMxDL, TMxAL - this step reads data from the 8-bit buffer.

Compact Type TM – CTM

Although the simplest form of the three TM types, the Compact TM type still contains three operating modes, which are Compare Match Output, Timer/Event Counter and PWM Output modes. The Compact TM can also be controlled with an external input pin and can drive one external output pin.

CTM	Name	TM No.	TM Input Pin	TM Output Pin
HT66F017 HT68F017	16-bit CTM	0	TCK0	TP0

Compact TM Operation

At its core is a 16-bit count-up counter which is driven by a user selectable internal or external clock source. There are also two internal comparators with the names, Comparator A and Comparator P. These comparators will compare the value in the counter with CCRP and CCRA registers. The CCRP is 8-bit wide whose value is compared with the highest eight bits in the counter while the CCRA is 16-bit wide and therefore compares with all counter bits.

The only way of changing the value of the 16-bit counter using the application program, is to clear the counter by changing the TnON bit from low to high. The counter will also be cleared automatically by a counter overflow or a compare match with one of its associated comparators. When these conditions occur, a TM interrupt signal will also usually be generated. The Compact Type TM can operate in a number of different operational modes, can be driven by different clock sources including an input pin and can also control an output pin. All operating setup conditions are selected using relevant internal registers.

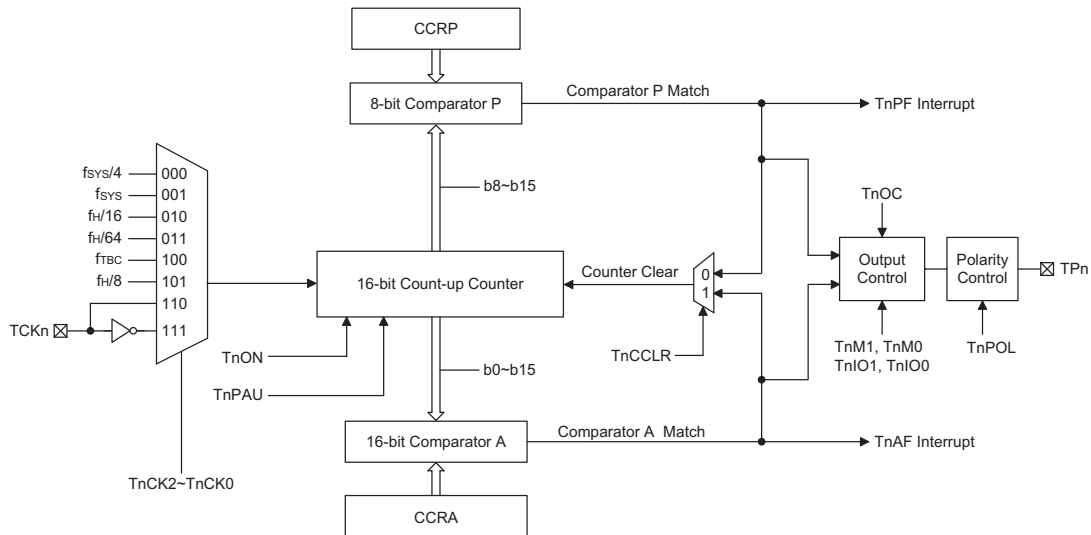

Compact Type TM Block Diagram

Compact Type TM Register Description

Overall operation of the Compact TM is controlled using a series of registers. A read only register pair exists to store the internal counter 16-bit value, while a read/write register pair exists to store the internal 16-bit CCRA value. There is also a read/write register used to store the internal 8-bit CCRP value. The remaining two registers are control registers which setup the different operating and control modes.

CTM Register List

Name	Bit7	Bit6	Bit5	Bit4	Bit3	Bit2	Bit1	Bit0
TM0C0	T0PAU	T0CK2	T0CK1	T0CK0	T0ON	—	—	—
TM0C1	T0M1	T0M0	T0IO1	T0IO0	T0OC	T0POL	T0DPX	T0CCLR
TM0DL	D7	D6	D5	D4	D3	D2	D1	D0
TM0DH	D15	D14	D13	D12	D11	D10	D9	D8
TM0AL	D7	D6	D5	D4	D3	D2	D1	D0
TM0AH	D15	D14	D13	D12	D11	D10	D9	D8
TM0RP	T0RP7	T0RP6	T0RP5	T0RP4	T0RP3	T0RP2	T0RP1	T0RP0

16-bit Compact TM Register List

• TM0DL Register

Bit	7	6	5	4	3	2	1	0
Name	D7	D6	D5	D4	D3	D2	D1	D0
R/W	R	R	R	R	R	R	R	R
POR	0	0	0	0	0	0	0	0

Bit 7~0 **TM0DL**: TM0 counter low byte register bit 7 ~ bit 0
TM0 16-bit Counter bit 7 ~ bit 0

• TM0DH Register

Bit	7	6	5	4	3	2	1	0
Name	D15	D14	D13	D12	D11	D10	D9	D8
R/W	R	R	R	R	R	R	R	R
POR	0	0	0	0	0	0	0	0

Bit 7~0 **TM0DH**: TM0 counter high byte register bit 7 ~ bit 0
TM0 16-bit counter bit 15 ~ bit 8

• TM0AL Register

Bit	7	6	5	4	3	2	1	0
Name	D7	D6	D5	D4	D3	D2	D1	D0
R/W	R/W	R/W	R/W	R/W	R/W	R/W	R/W	R/W
POR	0	0	0	0	0	0	0	0

Bit 7~0 **TM0AL**: TM0 CCRA low byte register bit 7 ~ bit 0
TM0 16-bit CCRA bit 7 ~ bit 0

• TM0AH Register

Bit	7	6	5	4	3	2	1	0
Name	D15	D14	D13	D12	D11	D10	D9	D8
R/W	R	R	R	R	R	R	R	R
POR	0	0	0	0	0	0	0	0

Bit 7~0 **TM0AH**: TM0 CCRA high byte register bit 7 ~ bit 0
TM0 16-bit CCRA bit 15 ~ bit 8

• **TM0C0 Register**

Bit	7	6	5	4	3	2	1	0
Name	T0PAU	T0CK2	T0CK1	T0CK0	T0ON	—	—	—
R/W	R/W	R/W	R/W	R/W	R/W	—	—	—
POR	0	0	0	0	0	—	—	—

- Bit 7** **T0PAU:** TM0 counter pause control
0: run
1: pause
The counter can be paused by setting this bit high. Clearing the bit to zero restores normal counter operation. When in a Pause condition the TM will remain powered up and continue to consume power. The counter will retain its residual value when this bit changes from low to high and resume counting from this value when the bit changes to a low value again.
- Bit 6~4** **T0CK2~T0CK0:** Select TM0 Counter clock
000: $f_{SYS}/4$
001: f_{SYS}
010: $f_H/16$
011: $f_H/64$
100: f_{TBC}
101: $f_H/8$
110: TCK0 rising edge clock
111: TCK0 falling edge clock
These three bits are used to select the clock source for the TM. The external pin clock source can be chosen to be active on the rising or falling edge. The clock source f_{SYS} is the system clock, while f_H and f_{TBC} are other internal clocks, the details of which can be found in the oscillator section.
- Bit 3** **T0ON:** TM0 Counter On/Off Control
0: Off
1: On
This bit controls the overall on/off function of the TM. Setting the bit high enables the counter to run, clearing the bit disables the TM. Clearing this bit to zero will stop the counter from counting and turn off the TM which will reduce its power consumption. When the bit changes state from low to high the internal counter value will be reset to zero, however when the bit changes from high to low, the internal counter will retain its residual value.
If the TM is in the Compare Match Output Mode then the TM output pin will be reset to its initial condition, as specified by the T0OC bit, when the T0ON bit changes from low to high.
- Bit 2~0** "—" Unimplemented, read as 0

• **TM0C1 Register**

Bit	7	6	5	4	3	2	1	0
Name	T0M1	T0M0	T0IO1	T0IO0	T0OC	T0POL	T0DPX	T0CCLR
R/W	R/W	R/W	R/W	R/W	R/W	R/W	R/W	R/W
POR	0	0	0	0	0	0	0	0

- Bit 7~6 T0M1~T0M0:** select TM0 operating mode
 00: compare match output mode
 01: undefined
 10: PWM mode
 11: Timer/Counter mode
 These bits setup the required operating mode for the TM. To ensure reliable operation the TM should be switched off before any changes are made to the T0M1 and T0M0 bits. In the Timer/Counter Mode, the TM output pin control must be disabled.
- Bit 5~4 T0IO1~T0IO0:** Select TP0 output function
 compare match output mode
 00: no change
 01: output low
 10: output high
 11: toggle output
 PWM Mode
 00: PWM output inactive state
 01: PWM output active state
 10: PWM output
 11: Undefined
 Timer/Counter mode
 unused
 These two bits are used to determine how the TM output pin changes state when a certain condition is reached. The function that these bits select depends upon in which mode the TM is running.
 In the Compare Match Output Mode, the T0IO1 and T0IO0 bits determine how the TM output pin changes state when a compare match occurs from the Comparator A. The TM output pin can be setup to switch high, switch low or to toggle its present state when a compare match occurs from the Comparator A. When the bits are both zero, then no change will take place on the output. The initial value of the TM output pin should be setup using the T0OC bit in the TM0C1 register. Note that the output level requested by the T0IO1 and T0IO0 bits must be different from the initial value setup using the T0OC bit otherwise no change will occur on the TM output pin when a compare match occurs. After the TM output pin changes state it can be reset to its initial level by changing the level of the T0ON bit from low to high.
 In the PWM Mode, the T0IO1 and T0IO0 bits determine how the TM output pin changes state when a certain compare match condition occurs. The PWM output function is modified by changing these two bits. It is necessary to change the values of the T0IO1 and T0IO0 bits only after the TMn has been switched off. Unpredictable PWM outputs will occur if the T0IO1 and T0IO0 bits are changed when the TM is running
- Bit 3 T0OC:** TP0 output control bit
 compare match output mode
 0: initial low
 1: initial high
 PWM mode
 0: active low
 1: active high
 This is the output control bit for the TM output pin. Its operation depends upon whether TM is being used in the Compare Match Output Mode or in the PWM Mode. It has no effect if the TM is in the Timer/Counter Mode. In the Compare Match Output Mode it determines the logic level of the TM output pin before a compare match occurs. In the PWM Mode it determines if the PWM signal is active high or active low.

- Bit 2** **TOPOL:** TP0 output polarity control
 0: non-invert
 1: invert
 This bit controls the polarity of the TP0 output pin. When the bit is set high the TM output pin will be inverted and not inverted when the bit is zero. It has no effect if the TM is in the Timer/Counter Mode.
- Bit 1** **TODPX:** TM0 PWM period/duty control
 0: CCRP - period; CCRA - duty
 1: CCRP - duty; CCRA - period
 This bit, determines which of the CCRA and CCRP registers are used for period and duty control of the PWM waveform.
- Bit 0** **T0CCLR:** select TM0 counter clear condition
 0: TM0 Comparatror P match
 1: TM0 Comparatror A match
 This bit is used to select the method which clears the counter. Remember that the Compact TM contains two comparators, Comparator A and Comparator P, either of which can be selected to clear the internal counter. With the T0CCLR bit set high, the counter will be cleared when a compare match occurs from the Comparator A. When the bit is low, the counter will be cleared when a compare match occurs from the Comparator P or with a counter overflow. A counter overflow clearing method can only be implemented if the CCRP bits are all cleared to zero. The T0CCLR bit is not used in the PWM Mode.

• **TM0RP Register**

Bit	7	6	5	4	3	2	1	0
Name	T0RP7	T0RP6	T0RP5	T0RP4	T0RP3	T0RP2	T0RP1	T0RP0
R/W	R/W	R/W	R/W	R/W	R/W	R/W	R/W	R/W
POR	0	0	0	0	0	0	0	0

- Bit 7~0** **T0RP7~T0RP0:** TM0 CCRP register bit 7~bit 0, compared with the TM0 counter bit 15~bit 8
 Comparator P match period =
 0: 65536 TM0 clocks
 1~255: $(1\sim255) \times 256$ TM0 clocks
 These eight bits are used to setup the value on the internal CCRP 8-bit register, which are then compared with the internal counter's highest eight bits. The result of this comparison can be selected to clear the internal counter if the T0CCLR bit is set to zero. Setting the T0CCLR bit to zero ensures that a compare match with the CCRP values will reset the internal counter. As the CCRP bits are only compared with the highest eight counter bits, the compare values exist in 256 clock cycle multiples. Clearing all eight bits to zero is in effect allowing the counter to overflow at its maximum value.

Compact Type TM Operating Modes

The Compact Type TM can operate in one of three operating modes, Compare Match Output Mode, PWM Mode or Timer/Counter Mode. The operating mode is selected using the TnM1 and TnM0 bits in the TMnC1 register.

Compare Match Output Mode

To select this mode, bits TnM1 and TnM0 in the TMnC1 register, should be set to 00B respectively. In this mode once the counter is enabled and running it can be cleared by three methods. These are a counter overflow, a compare match from Comparator A and a compare match from Comparator P. When the TnCCLR bit is low, there are two ways in which the counter can be cleared. One is when a compare match occurs from Comparator P, the other is when the CCRP bits are all zero which allows the counter to overflow. Here both TnAF and TnPF interrupt request flags for the Comparator A and Comparator P respectively, will both be generated.

If the TnCCLR bit in the TMnC1 register is high then the counter will be cleared when a compare match occurs from Comparator A. However, here only the TnAF interrupt request flag will be generated even if the value of

the CCRP bits is less than that of the CCRA registers. Therefore when TnCCLR is high no TnPF interrupt request flag will be generated. If the CCRA bits are all zero, the counter will overflow when it reaches its maximum 16-bit, FFFF Hex, value, however here the TnAF interrupt request flag will not be generated.

As the name of the mode suggests, after a comparison is made, the TM output pin will change state. The TM output pin condition however only changes state when a TnAF interrupt request flag is generated after a compare match occurs from Comparator A. The TnPF interrupt request flag, generated from a compare match occurs from Comparator P, will have no effect on the TM output pin. The way in which the TM output pin changes state are determined by the condition of the TnIO1 and TnIO0 bits in the TMnC1 register. The TM output pin can be selected using the TnIO1 and TnIO0 bits to go high, to go low or to toggle from its present condition when a compare match occurs from Comparator A. The initial condition of the TM output pin, which is setup after the TnON bit changes from low to high, is setup using the TnOC bit. Note that if the TnIO1 and TnIO0 bits are zero then no pin change will take place.

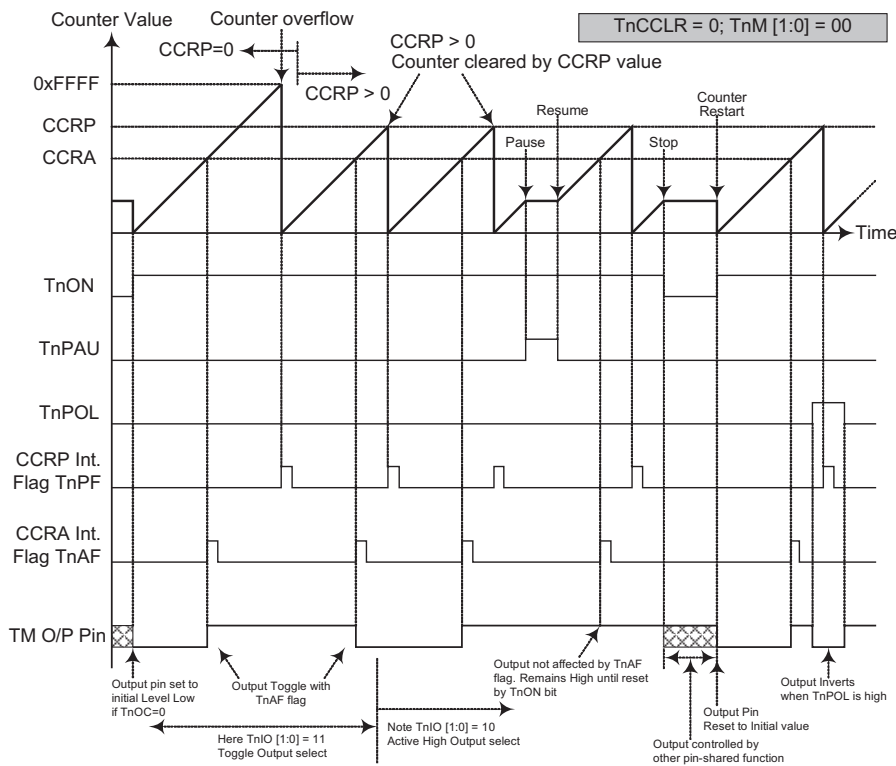

- Note:
1. With TnCCLR=0, a Comparator P match will clear the counter
 2. The TM output pin is controlled only by the TnAF flag
 3. The output pin is reset to its initial state by a TnON bit rising edge

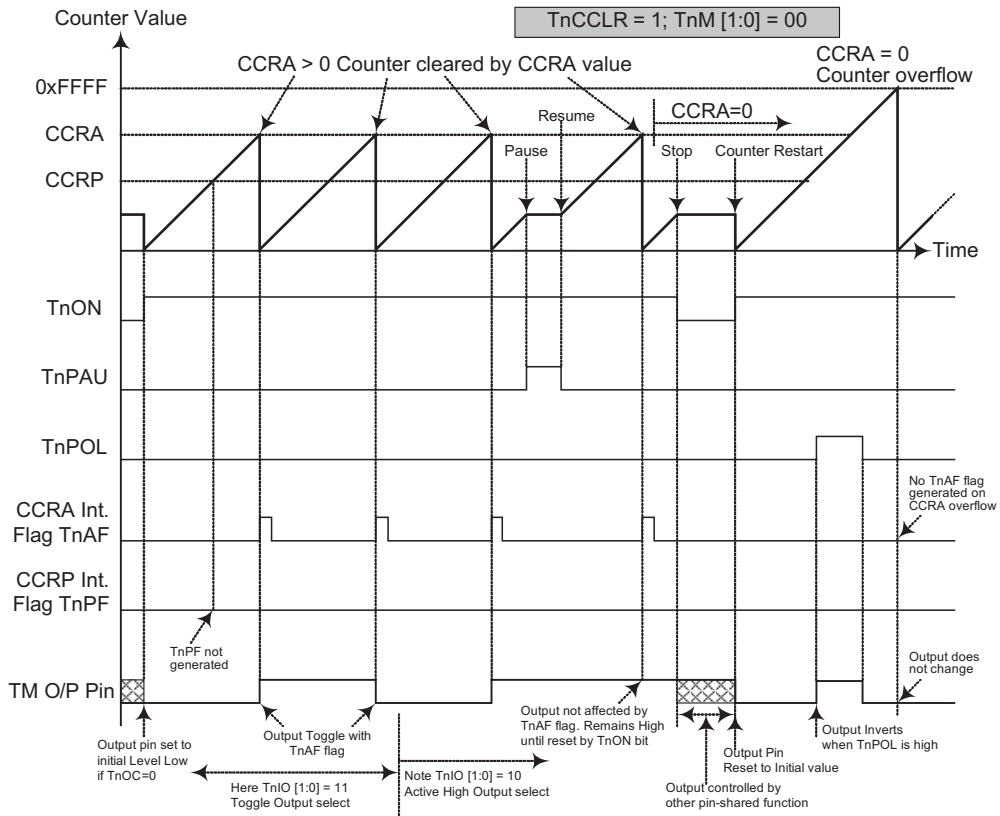

Compare Match Output Mode -- TnCCLR = 1

- Note:
1. With $TnCCLR=1$, a Comparator A match will clear the counter
 2. The TM output pin is controlled only by the TnAF flag
 3. The output pin is reset to its initial state by a TnON bit rising edge
 4. The TnPF flag is not generated when $TnCCLR=1$

Timer/Counter Mode

To select this mode, bits TnM1 and TnM0 in the TMnC1 register should be set to 11 respectively. The Timer/Counter Mode operates in an identical way to the Compare Match Output Mode generating the same interrupt flags. The exception is that in the Timer/Counter Mode the TM output pin is not used. Therefore the above description and Timing Diagrams for the Compare Match Output Mode can be used to understand its function. As the TM output pin is not used in this mode, the pin can be used as a normal I/O pin or other pin-shared function.

PWM Output Mode

To select this mode, bits TnM1 and TnM0 in the TMnC1 register should be set to 10 respectively. The PWM function within the TM is useful for applications which require functions such as motor control, heating control, illumination control etc. By providing a signal of fixed frequency but of varying duty cycle on the TM output pin, a square wave AC waveform can be generated with varying equivalent DC RMS values.

As both the period and duty cycle of the PWM waveform can be controlled, the choice of generated waveform is extremely flexible. In the PWM mode, the TnCCLR bit has no effect on the PWM operation. Both of the CCRA and CCRP registers are used to generate the PWM waveform, one register is used to clear the internal counter and thus control the PWM waveform frequency, while the other one is used to control the duty cycle. Which register is used to control either frequency or duty cycle is determined using the TnDPX bit in the TMnC1 register. The PWM waveform frequency and duty cycle can therefore be controlled by the values in the CCRA and CCRP registers.

An interrupt flag, one for each of the CCRA and CCRP, will be generated when a compare match occurs from either Comparator A or Comparator P. The TnOC bit in the TMnC1 register is used to select the required polarity of the PWM waveform while the two TnIO1 and TnIO0 bits are used to enable the PWM output or to force the TM output pin to a fixed high or low level. The TnPOL bit is used to reverse the polarity of the PWM output waveform.

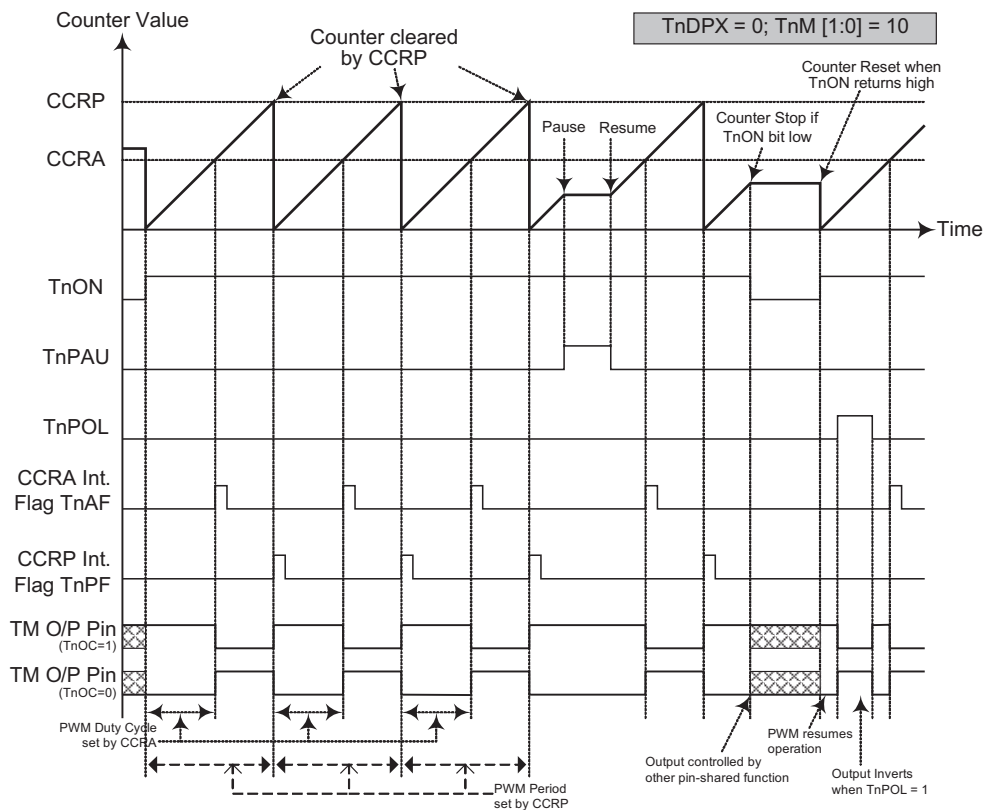

- Note:
1. Here TnDPX=0 -- Counter cleared by CCRP
 2. A counter clear sets the PWM Period
 3. The internal PWM function continues running even when TnIO [1:0] = 00 or 01
 4. The TnCCLR bit has no influence on PWM operation

- 16-bit CTM, PWM Mode, Edge-aligned Mode, TnDPX=0

CCRP	1~255	0
Period	CCRP × 256	65536
Duty	CCRA	

If $f_{SYS} = 16\text{MHz}$, TM clock source is $f_{SYS}/4$, CCRP = 2 and CCRA = 128

The CTM PWM output frequency = $(f_{SYS}/4) / (2 \times 256) = f_{SYS}/2048 = 7.8125\text{ kHz}$, duty = $128 / (2 \times 256) = 25\%$.

If the Duty value defined by the CCRA register is equal to or greater than the Period value, then the PWM output duty is 100%.

- 16-bit CTM, PWM Mode, Edge-aligned Mode, TnDPX=1

CCRP	1~255	0
Period	CCRA	
Duty	CCRP × 256	65536

The PWM output period is determined by the CCRA register value together with the TM clock while the PWM duty cycle is defined by the (CCRP×256) except when the CCRP value is equal to 0.

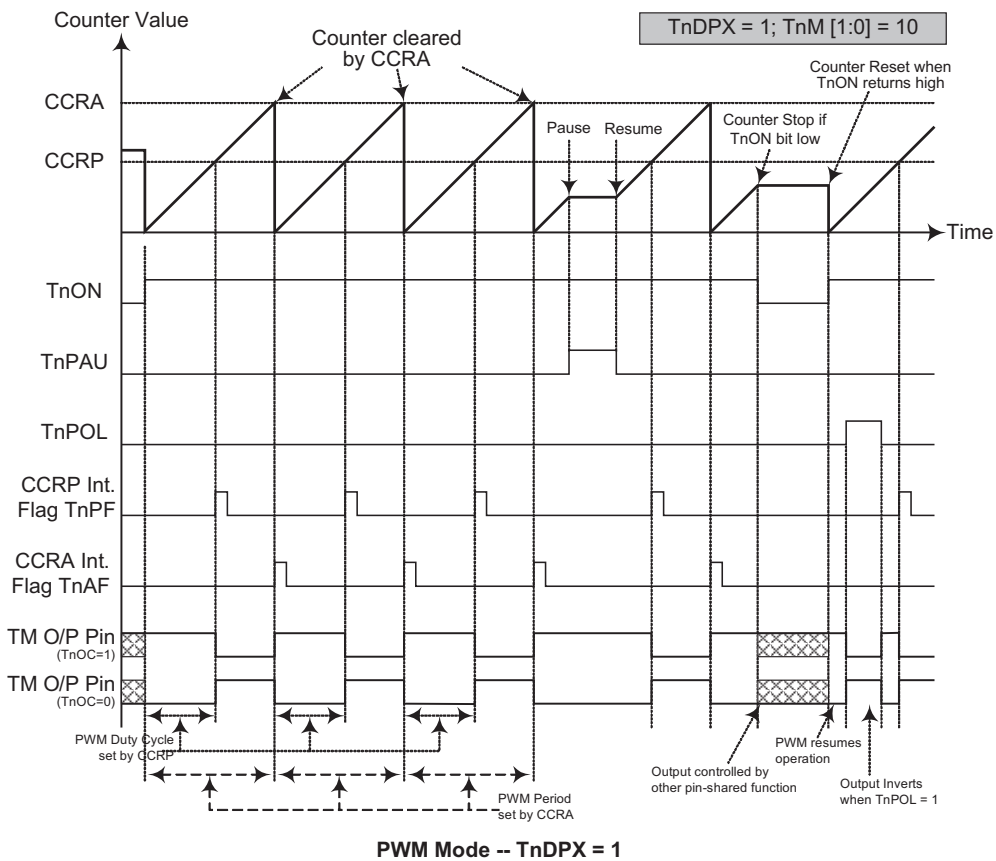

- Note:
- Here TnDPX = 1 -- Counter cleared by CCRA
 - A counter clear sets the PWM Period
 - The internal PWM function continues running even when TnIO [1:0] = 00 or 01
 - The TnCCLR bit has no influence on PWM operation

Standard Type TM – STM

The Standard Type TM contains five operating modes, which are Compare Match Output, Timer/Event Counter, Capture Input, Single Pulse Output and PWM Output modes. The Standard TM can also be controlled with an external input pin and can drive one or two external output pins.

STM	Name	TM No.	TM Input Pin	TM Output Pin
All devices	16-bit STM	1	TCK1	TP1

Standard TM Operation

At its core is a 16-bit count-up counter which is driven by a user selectable internal or external clock source. There are also two internal comparators with the names, Comparator A and Comparator P. These comparators will compare the value in the counter with CCRP and CCRA registers. The CCRP comparator is 8-bit wide whose value is compared with the highest eight bits in the counter while the CCRA is 16-bit wide and therefore compares with all counter bits.

The only way of changing the value of the 16-bit counter using the application program, is to clear the counter by changing the TnON bit from low to high. The counter will also be cleared automatically by a counter overflow or a compare match with one of its associated comparators. When these conditions occur, a TM interrupt signal will

also usually be generated. The Standard Type TM can operate in a number of different operational modes, can be driven by different clock sources including an input pin and can also control an output pin. All operating setup conditions are selected using relevant internal registers.

Standard Type TM Register Description

Overall operation of the Standard TM is controlled using a series of registers. A read only register pair exists to store the internal counter 16-bit value, while a read/write register pair exists to store the internal 16-bit CCRA value. There is also a read/write register used to store the internal 8-bit CCRP value. The remaining two registers are control registers which setup the different operating and control modes.

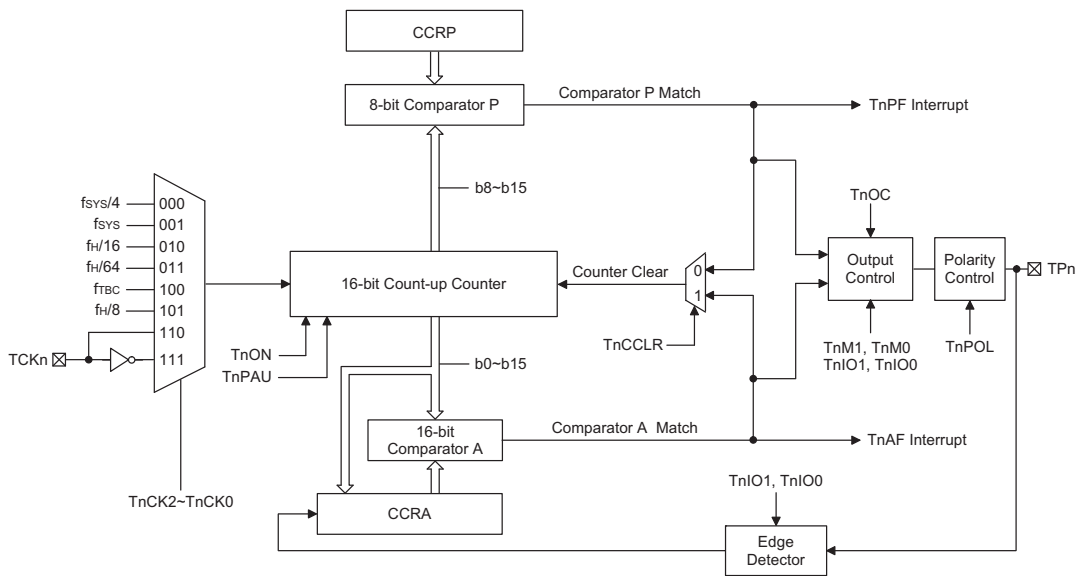

Standard Type TM Block Diagram

STM Register List

Name	Bit7	Bit6	Bit5	Bit4	Bit3	Bit2	Bit1	Bit0
TM1C0	T1PAU	T1CK2	T1CK1	T1CK0	T1ON	—	—	—
TM1C1	T1M1	T1M0	T1IO1	T1IO0	T1OC	T1POL	T1DPX	T1CCLR
TM1DL	D7	D6	D5	D4	D3	D2	D1	D0
TM1DH	D15	D14	D13	D12	D11	D10	D9	D8
TM1AL	D7	D6	D5	D4	D3	D2	D1	D0
TM1AH	D15	D14	D13	D12	D11	D10	D9	D8
TM1RP	T1RP7	T1RP6	T1RP5	T1RP4	T1RP3	T1RP2	T1RP1	T1RP0

16-bit Standard TM Register List

• TM1C0 Register

Bit	7	6	5	4	3	2	1	0
Name	T1PAU	T1CK2	T1CK1	T1CK0	T1ON	—	—	—
R/W	R/W	R/W	R/W	R/W	R/W	—	—	—
POR	0	0	0	0	0	—	—	—

- Bit 7** **T1PAU:** TM1 counter pause control
0: run
1: pause
The counter can be paused by setting this bit high. Clearing the bit to zero restores normal counter operation. When in a Pause condition the TM will remain powered up and continue to consume power. The counter will retain its residual value when this bit changes from low to high and resume counting from this value when the bit changes to a low value again.
- Bit 6~4** **T1CK2~T1CK0:** select TM1 counter clock
000: $f_{SYS}/4$
001: f_{SYS}
010: $f_H/16$
011: $f_H/64$
100: f_{TBC}
101: $f_H/8$
110: TCK1 rising edge clock
111: TCK1 falling edge clock
These three bits are used to select the clock source for the TM. The external pin clock source can be chosen to be active on the rising or falling edge. The clock source f_{SYS} is the system clock, while f_H and f_{TBC} are other internal clocks, the details of which can be found in the oscillator section.
- Bit 3** **T1ON:** TM1 counter On/Off control
0: Off
1: On
This bit controls the overall on/off function of the TM. Setting the bit high enables the counter to run, clearing the bit disables the TM. Clearing this bit to zero will stop the counter from counting and turn off the TM which will reduce its power consumption. When the bit changes state from low to high the internal counter value will be reset to zero, however when the bit changes from high to low, the internal counter will retain its residual value until the bit returns high again.
If the TM is in the Compare Match Output Mode then the TM output pin will be reset to its initial condition, as specified by the T1OC bit, when the T1ON bit changes from low to high.
- Bit 2~0** unimplemented, read as 0

• TM1C1 Register

Bit	7	6	5	4	3	2	1	0
Name	T1M1	T1M0	T1IO1	T1IO0	T1OC	T1POL	T1DPX	T1CCLR
R/W	R/W	R/W	R/W	R/W	R/W	R/W	R/W	R/W
POR	0	0	0	0	0	0	0	0

- Bit 7~6 T1M1~T1M0:** select TM1 operating mode
 00: Compare match output mode
 01: Capture input mode
 10: PWM mode or single pulse output mode
 11: Timer/Counter mode
 These bits setup the required operating mode for the TM. To ensure reliable operation the TM should be switched off before any changes are made to the T1M1 and T1M0 bits. In the Timer/Counter Mode, the TM output pin control must be disabled.
- Bit 5~4 T1IO1~T1IO0:** select TP1 output function
 Compare match output mode
 00: no change
 01: output low
 10: output high
 11: toggle output
 PWM mode/single pulse output mode
 00: PWM output inactive state
 01: PWM output active state
 10: PWM output
 11: Single pulse output
 Capture input mode
 00: input capture at rising edge of TP1
 01: input capture at falling edge of TP1
 10: input capture at falling/rising edge of TP1
 11: input capture disabled
 Timer/counter mode
 Unused
 These two bits are used to determine how the TM output pin changes state when a certain condition is reached. The function that these bits select depends upon in which mode the TM is running.
 In the Compare Match Output Mode, the T1IO1 and T1IO0 bits determine how the TM output pin changes state when a compare match occurs from the Comparator A. The TM output pin can be setup to switch high, switch low or to toggle its present state when a compare match occurs from the Comparator A. When the bits are both zero, then no change will take place on the output. The initial value of the TM output pin should be setup using the T1OC bit in the TM1C1 register. Note that the output level requested by the T1IO1 and T1IO0 bits must be different from the initial value setup using the T1OC bit otherwise no change will occur on the TM output pin when a compare match occurs. After the TM output pin changes state it can be reset to its initial level by changing the level of the T1ON bit from low to high.
 In the PWM Mode, the T1IO1 and T1IO0 bits determine how the TM output pin changes state when a certain compare match condition occurs. The PWM output function is modified by changing these two bits. It is necessary to change the values of the T1IO1 and T1IO0 bits only after the TM has been switched off. Unpredictable PWM outputs will occur if the T1IO1 and T1IO0 bits are changed when the TM is running

- Bit 3** **T1OC:** TP1 output control bit
Compare match output mode
0: initial low
1: initial high
PWM mode/single pulse output mode
0: active low
1: active high
This is the output control bit for the TM output pin. Its operation depends upon whether TM is being used in the Compare Match Output Mode or in the PWM Mode/ Single Pulse Output Mode. It has no effect if the TM is in the Timer/Counter Mode. In the Compare Match Output Mode it determines the logic level of the TM output pin before a compare match occurs. In the PWM Mode it determines if the PWM signal is active high or active low.
- Bit 2** **T1POL:** TP1 output polarity control
0: non-invert
1: invert
This bit controls the polarity of the TP1 output pin. When the bit is set high the TM output pin will be inverted and not inverted when the bit is zero. It has no effect if the TM is in the Timer/Counter mode.
- Bit 1** **T1DPX:** TM1 PWM period/duty control
0: CCRP - period; CCRA - duty
1: CCRP - duty; CCRA - period
This bit, determines which of the CCRA and CCRP registers are used for period and duty control of the PWM waveform.
- Bit 0** **T1CCLR:** select TM1 counter clear condition
0: TM1 Comparatror P match
1: TM1 Comparatror A match
This bit is used to select the method which clears the counter. Remember that the Standard TM contains two comparators, Comparator A and Comparator P, either of which can be selected to clear the internal counter. With the T1CCLR bit set high, the counter will be cleared when a compare match occurs from the Comparator A. When the bit is low, the counter will be cleared when a compare match occurs from the Comparator P or with a counter overflow. A counter overflow clearing method can only be implemented if the CCRP bits are all cleared to zero. The T1CCLR bit is not used in the PWM, Single Pulse or Input Capture Mode.

• **TM1DL Register**

Bit	7	6	5	4	3	2	1	0
Name	D7	D6	D5	D4	D3	D2	D1	D0
R/W	R	R	R	R	R	R	R	R
POR	0	0	0	0	0	0	0	0

Bit 7~0 **TM1DL:** TM1 counter low byte register bit 7~bit 0
TM1 16-bit counter bit 7~bit 0

• **TM1DH Register**

Bit	7	6	5	4	3	2	1	0
Name	D15	D14	D13	D12	D11	D10	D9	D8
R/W	R/W	R/W	R/W	R/W	R/W	R/W	R/W	R/W
POR	0	0	0	0	0	0	0	0

Bit 7~0 **TM1DH:** TM1 counter high byte register bit 7~bit 0
TM1 16-bit Counter bit 15~bit 8

• TM1AL Register

Bit	7	6	5	4	3	2	1	0
Name	D7	D6	D5	D4	D3	D2	D1	D0
R/W	R/W	R/W	R/W	R/W	R/W	R/W	R/W	R/W
POR	0	0	0	0	0	0	0	0

Bit 7~0 **TM1AL**: TM1 CCRA low byte register bit 7~bit 0
 TM1 16-bit CCRA bit 7~bit 0

• TM1AH Register

Bit	7	6	5	4	3	2	1	0
Name	D15	D14	D13	D12	D11	D10	D9	D8
R/W	R/W	R/W	R/W	R/W	R/W	R/W	R/W	R/W
POR	0	0	0	0	0	0	0	0

Bit 7~0 **TM1AH**: TM1 CCRA high byte register bit 7~bit 0
 TM1 16-bit CCRA bit 15~bit 8

• TM1RP Register

Bit	7	6	5	4	3	2	1	0
Name	T1RP7	T1RP6	T1RP5	T1RP4	T1RP3	T1RP2	T1RP1	T1RP0
R/W	R/W	R/W	R/W	R/W	R/W	R/W	R/W	R/W
POR	0	0	0	0	0	0	0	0

Bit 7~0 **T1RP7~T1RP0**: TM1 CCRP register bit 7~bit 0, compared with the TM1 counter bit 15~bit 8
 Comparator P Match Period =
 0: 65536 TM1 clocks
 1~255: (1~255) × 256 TM1 clocks
 These eight bits are used to setup the value on the internal CCRP 8-bit register, which are then compared with the internal counter's highest eight bits. The result of this comparison can be selected to clear the internal counter if the T1CCLR bit is set to zero. Setting the T1CCLR bit to zero ensures that a compare match with the CCRP values will reset the internal counter. As the CCRP bits are only compared with the highest eight counter bits, the compare values exist in 256 clock cycle multiples. Clearing all eight bits to zero is in effect allowing the counter to overflow at its maximum value.

Standard Type TM Operating Modes

The Standard Type TM can operate in one of five operating modes, Compare Match Output Mode, PWM Mode, Single Pulse Output Mode, Capture Input Mode or Timer/Counter Mode. The operating mode is selected using the TnM1 and TnM0 bits in the TMnC1 register.

Compare Output Mode

To select this mode, bits TnM1 and TnM0 in the TMnC1 register, should be set to 00 respectively. In this mode once the counter is enabled and running it can be cleared by three methods. These are a counter overflow, a compare match from Comparator A and a compare match from Comparator P. When the TnCCLR bit is low, there are two ways in which the counter can be cleared. One is when a compare match from Comparator P, the other is when the CCRP bits are all zero which allows the counter to overflow. Here both TnAF and TnPF interrupt request flags for Comparator A and Comparator P respectively, will both be generated.

If the TnCCLR bit in the TMnC1 register is high then the counter will be cleared when a compare match occurs from Comparator A. However, here only the TnAF inter-

rupt request flag will be generated even if the value of the CCRP bits is less than that of the CCRA registers. Therefore when TnCCLR is high no TnPF interrupt request flag will be generated. In the Compare Match Output Mode, the CCRA can not be set to 0.

As the name of the mode suggests, after a comparison is made, the TM output pin, will change state. The TM output pin condition however only changes state when a TnAF interrupt request flag is generated after a compare match occurs from Comparator A. The TnPF interrupt request flag, generated from a compare match occurs from Comparator P, will have no effect on the TM output pin. The way in which the TM output pin changes state are determined by the condition of the TnIO1 and TnIO0 bits in the TMnC1 register. The TM output pin can be selected using the TnIO1 and TnIO0 bits to go high, to go low or to toggle from its present condition when a compare match occurs from Comparator A. The initial condition of the TM output pin, which is setup after the TnON bit changes from low to high, is setup using the TnOC bit. Note that if the TnIO1 and TnIO0 bits are zero then no pin change will take place.

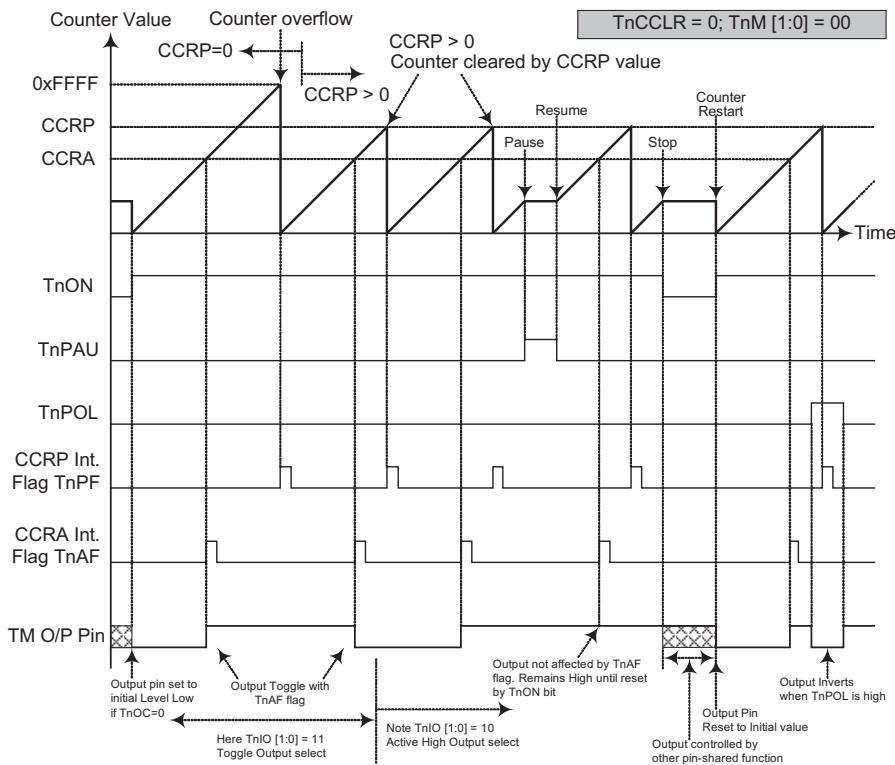

Compare Match Output Mode -- TnCCLR = 0

- Note:
1. With TnCCLR=0, a Comparator P match will clear the counter
 2. The TM output pin is controlled only by the TnAF flag
 3. The output pin is reset to its initial state by a TnON bit rising edge

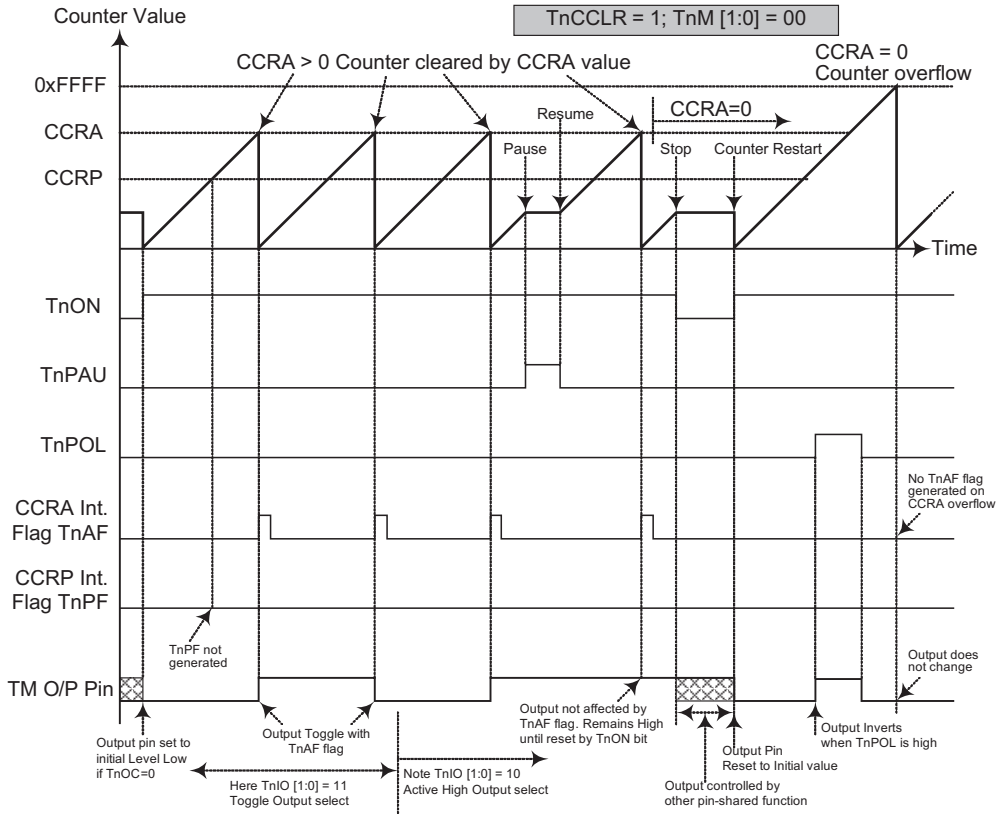

Compare Match Output Mode -- TnCCLR = 1

- Note:
1. With $TnCCLR=1$, a Comparator A match will clear the counter
 2. The TM output pin is controlled only by the TnAF flag
 3. The output pin is reset to its initial state by a TnON bit rising edge
 4. A TnPF flag is not generated when $TnCCLR=1$

Timer/Counter Mode

To select this mode, bits TnM1 and TnM0 in the TMnC1 register should be set to 11 respectively. The Timer/Counter Mode operates in an identical way to the Compare Match Output Mode generating the same interrupt flags. The exception is that in the Timer/Counter Mode the TM output pin is not used. Therefore the above description and Timing Diagrams for the Compare Match Output Mode can be used to understand its function. As the TM output pin is not used in this mode, the pin can be used as a normal I/O pin or other pin-shared function.

PWM Output Mode

To select this mode, bits TnM1 and TnM0 in the TMnC1 register should be set to 10 respectively. The PWM function within the TM is useful for applications which require functions such as motor control, heating control, illumination control etc. By providing a signal of fixed frequency but of varying duty cycle on the TM output pin, a square wave AC waveform can be generated with varying equivalent DC RMS values.

As both the period and duty cycle of the PWM waveform can be controlled, the choice of generated waveform is extremely flexible. In the PWM mode, the TnCCLR bit has no effect on the PWM operation. Both of the CCRA and CCRP registers are used to generate the PWM waveform, one register is used to clear the internal counter and thus control the PWM waveform frequency, while the other one is used to control the duty cycle. Which register is used to control either frequency or duty cycle is determined using the TnDPX bit in the TMnC1 register. The PWM waveform frequency and duty cycle can therefore be controlled by the values in the CCRA and CCRP registers.

An interrupt flag, one for each of the CCRA and CCRP, will be generated when a compare match occurs from either Comparator A or Comparator P. The TnOC bit in the TMnC1 register is used to select the required polarity of the PWM waveform while the two TnIO1 and TnIO0 bits are used to enable the PWM output or to force the TM output pin to a fixed high or low level. The TnPOL bit is used to reverse the polarity of the PWM output waveform.

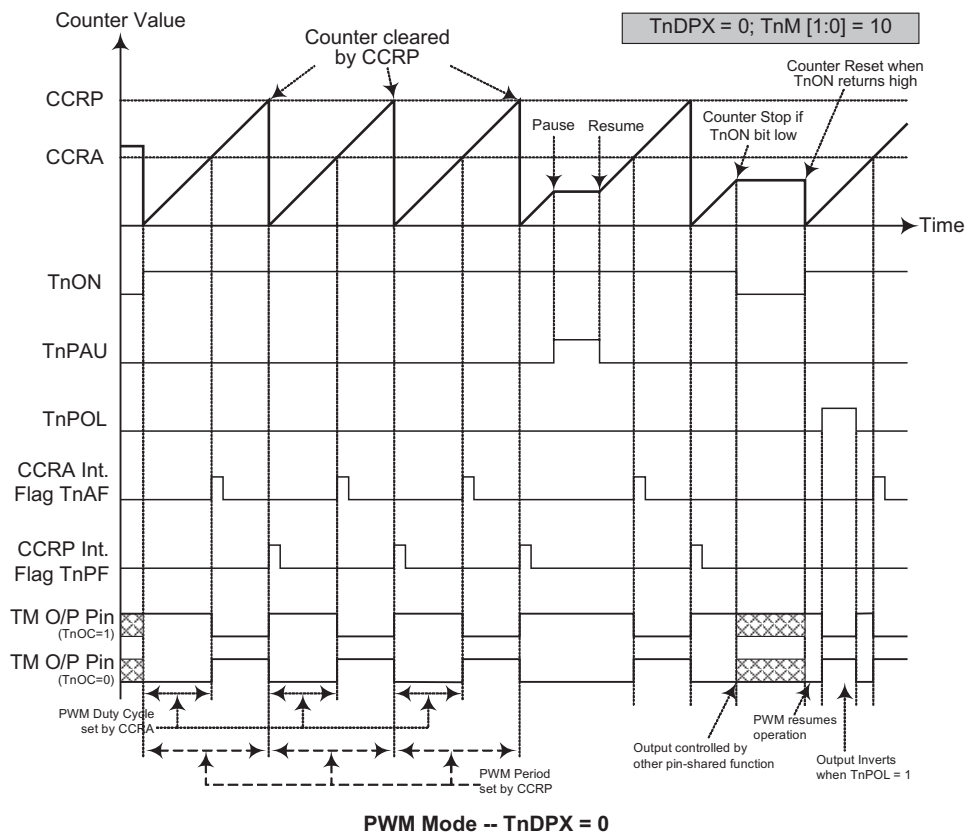

- Note:
1. Here TnDPX=0 -- Counter cleared by CCRP
 2. A counter clear sets the PWM Period
 3. The internal PWM function continues running even when TnIO [1:0] = 00 or 01
 4. The TnCCLR bit has no influence on PWM operation

- 16-bit STM, PWM Mode, Edge-aligned Mode, TnDPX=0

CCRP	1~255	0
Period	CCRP × 256	65536
Duty	CCRA	

If $f_{SYS} = 16\text{MHz}$, TM clock source is $f_{SYS}/4$, CCRP = 2 and CCRA = 128

The STM PWM output frequency = $(f_{SYS}/4) / (2 \times 256) = f_{SYS}/2048 = 7.8125\text{kHz}$, duty = $128 / (2 \times 256) = 25\%$.

If the Duty value defined by the CCRA register is equal to or greater than the Period value, then the PWM output duty is 100%.

- 16-bit STM, PWM Mode, Edge-aligned Mode, TnDPX=1

CCRP	1~255	0
Period	CCRA	
Duty	CCRP × 256	65536

The PWM output period is determined by the CCRA register value together with the TM clock while the PWM duty cycle is defined by the (CCRP×256) except when the CCRP value is equal to 0.

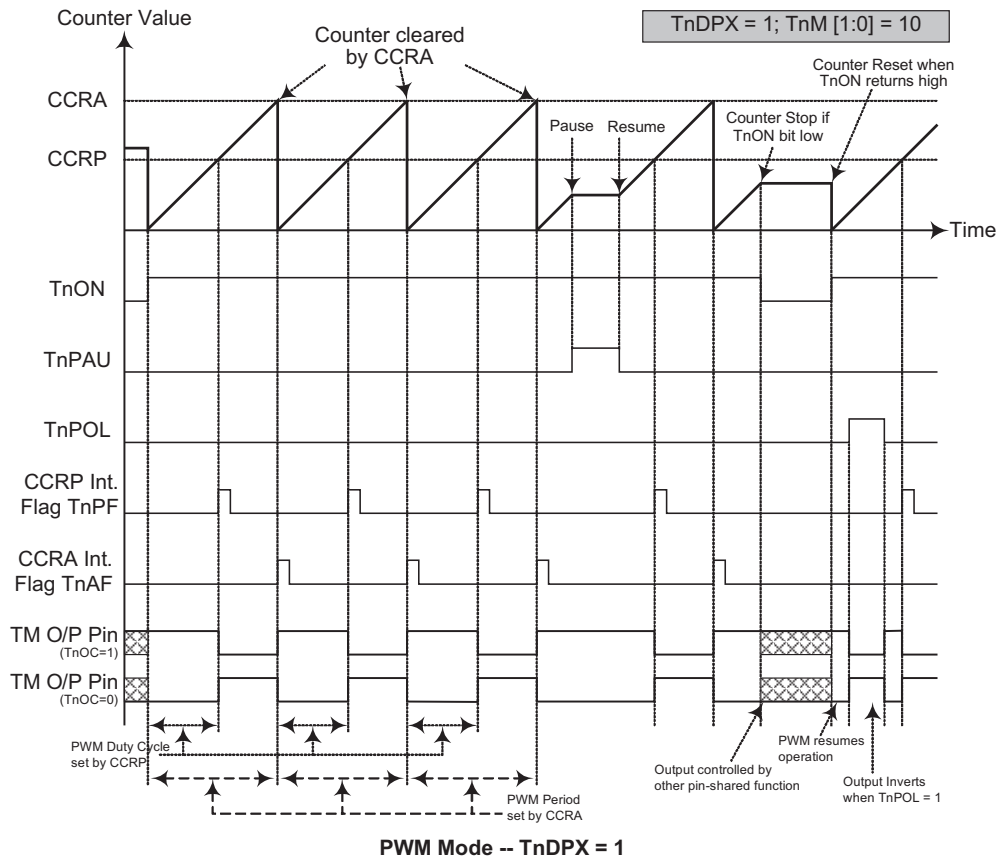

- Note:
- Here TnDPX=1 -- Counter cleared by CCRA
 - A counter clear sets the PWM Period
 - The internal PWM function continues running even when TnIO [1:0] = 00 or 01
 - The TnCCLR bit has no influence on PWM operation

Single Pulse Mode

To select this mode, bits TnM1 and TnM0 in the TMnC1 register should be set to 10 respectively and also the TnIO1 and TnIO0 bits should be set to 11 respectively. The Single Pulse Output Mode, as the name suggests, will generate a single shot pulse on the TM output pin.

The trigger for the pulse output leading edge is a low to high transition of the TnON bit, which can be implemented using the application program. However in the Single Pulse Mode, the TnON bit can also be made to

automatically change from low to high using the external TCKn pin, which will in turn initiate the Single Pulse output. When the TnON bit transitions to a high level, the counter will start running and the pulse leading edge will be generated. The TnON bit should remain high when the pulse is in its active state. The generated pulse trailing edge will be generated when the TnON bit is cleared to zero, which can be implemented using the application program or when a compare match occurs from Comparator A.

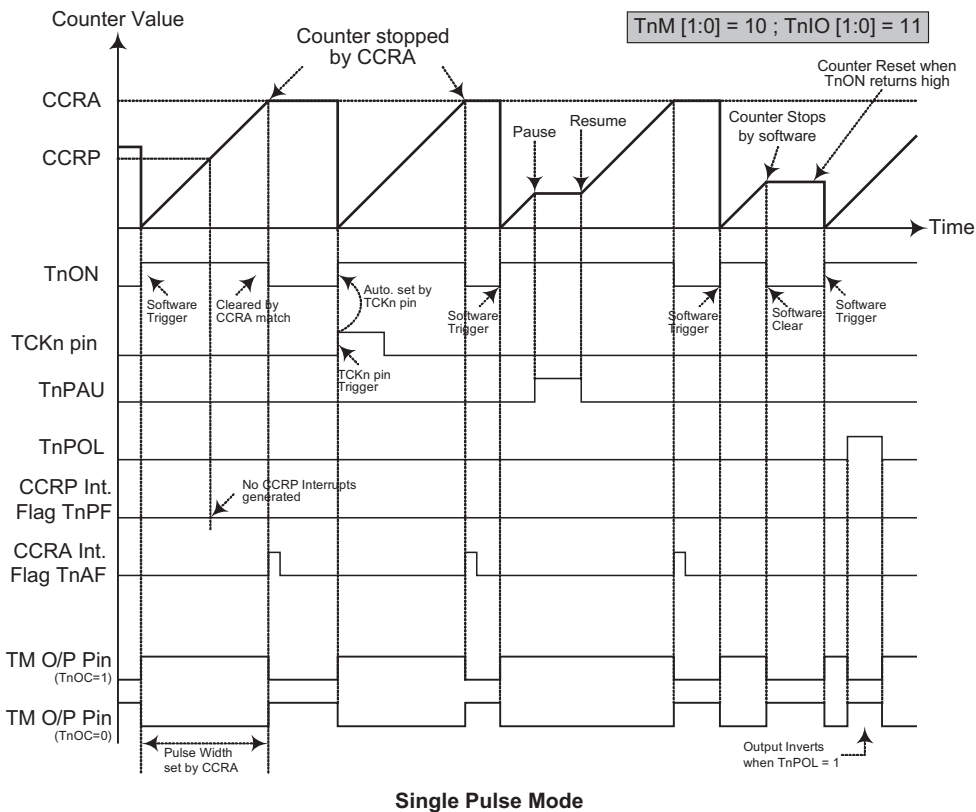
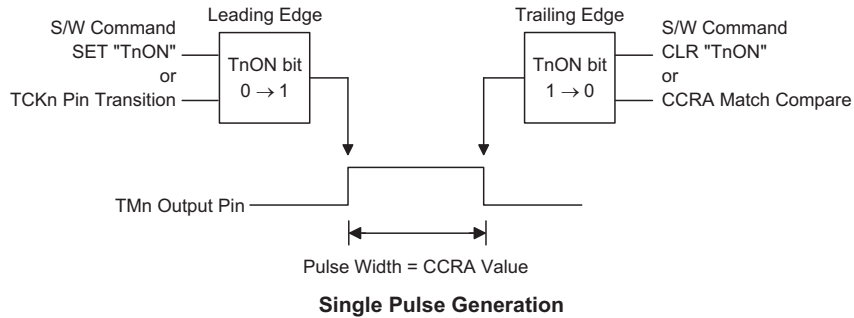

- Note:
1. Counter stopped by CCRA
 2. CCRP is not used
 3. The pulse triggered by the TCKn pin or by setting the TnON bit high
 4. A TCKn pin active edge will automatically set the TnON bit high.
 5. In the Single Pulse Mode, TnIO [1:0] must be set to "11" and can not be changed.

However a compare match from Comparator A will also automatically clear the TnON bit and thus generate the Single Pulse output trailing edge. In this way the CCRA value can be used to control the pulse width. A compare match from Comparator A will also generate a TM interrupt. The counter can only be reset back to zero when the TnON bit changes from low to high when the counter restarts. In the Single Pulse Mode CCRP is not used. The TnCCLR and TnDPX bits are not used in this Mode.

Capture Input Mode

To select this mode bits TnM1 and TnM0 in the TMnC1 register should be set to 01 respectively. This mode enables external signals to capture and store the present value of the internal counter and can therefore be used for applications such as pulse width measurements. The external signal is supplied on the TPn pin, whose active edge can be either a rising edge, a falling edge or both rising and falling edges; the active edge transition type is selected using the TnIO1 and TnIO0 bits in the TMnC1 register. The counter is started when the TnON bit changes from low to high which is initiated using the application program.

When the required edge transition appears on the TPn pin, the present value in the counter will be latched into

the CCRA registers and a TM interrupt generated. Irrespective of what events occur on the TPn pin the counter will continue to free run until the TnON bit changes from high to low. When a CCRP compare match occurs, the counter will reset back to zero; in this way the CCRP value can be used to control the maximum counter value. When a CCRP compare match occurs from Comparator P, a TM interrupt will also be generated. Counting the number of overflow interrupt signals from the CCRP can be a useful method in measuring long pulse widths. The TnIO1 and TnIO0 bits can select the active trigger edge on the TPn pin to be a rising edge, falling edge or both edge types. If the TnIO1 and TnIO0 bits are both set high, then no capture operation will take place irrespective of what happens on the TPn pin, however it must be noted that the counter will continue to run.

As the TPn pin is pin shared with other functions, care must be taken if the TM is in the Input Capture Mode. This is because if the pin is setup as an output, then any transitions on this pin may cause an input capture operation to be executed. The TnCCLR and TnDPX bits are not used in this Mode.

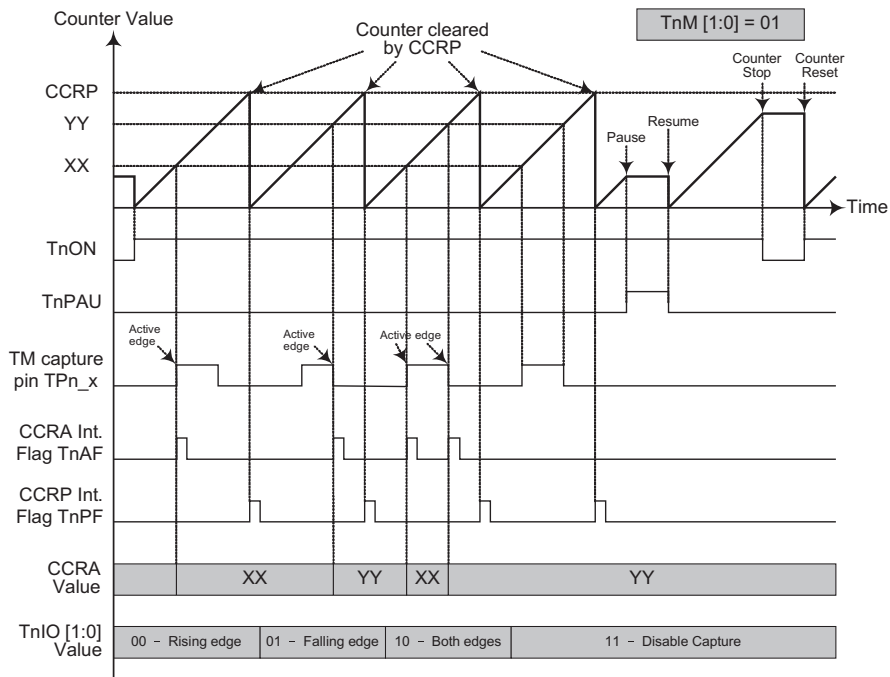

Capture Input Mode

- Note:
1. TnM [1:0] = 01 and active edge set by the TnIO [1:0] bits
 2. A TM Capture input pin active edge transfers the counter value to CCRA
 3. The TnCCLR bit is not used
 4. No output function -- TnOC and TnPOL bits are not used
 5. CCRP determines the counter value and the counter has a maximum count value when CCRP is equal to zero.

Analog to Digital Converter

The need to interface to real world analog signals is a common requirement for many electronic systems. However, to properly process these signals by a microcontroller, they must first be converted into digital signals by A/D converters. By integrating the A/D conversion electronic circuitry into the microcontroller, the need for external components is reduced significantly with the corresponding follow-on benefits of lower costs and reduced component space requirements.

A/D Overview

The device contains a multi-channel analog to digital converter which can directly interface to external analog signals, such as that from sensors or other control signals and convert these signals directly into either a 12-bit digital value.

Part No.	Input Channels	A/D Channel Select Bits	Input Pins
HT66F016 HT66F017	4	ACS4, ACS1~ACS0	AN0~AN3
HT68F016 HT68F017	—	—	—

The accompanying block diagram shows the overall internal structure of the A/D converter, together with its associated registers.

A/D Converter Register Description

Overall operation of the A/D converter is controlled using five registers. A read only register pair exists to store the ADC data 12-bit value. The remaining three registers are control registers which setup the operating and control function of the A/D converter.

Register Name	Bit							
	7	6	5	4	3	2	1	0
ADRL(ADRF=0)	D3	D2	D1	D0	—	—	—	—
ADRL(ADRF=1)	D7	D6	D5	D4	D3	D2	D1	D0
ADRH(ADRF=0)	D11	D10	D9	D8	D7	D6	D5	D4
ADRH(ADRF=1)	—	—	—	—	D11	D10	D9	D8
ADCR0	START	EOCB	ADOFF	ADRF	—	—	ACS1	ACS0
ADCR1	ACS4	V125EN	—	VREFS	—	ADCK2	ADCK1	ADCK0
ACERL	—	—	—	—	ACE3	ACE2	ACE1	ACE0

A/D Converter Register List

A/D Converter Data Registers – ADRL, ADRH

As the devices contain an internal 12-bit A/D converter, they require two data registers to store the converted value. These are a high byte register, known as ADRH, and a low byte register, known as ADRL. After the conversion process takes place, these registers can be directly read by the microcontroller to obtain the digitised conversion value. As only 12 bits of the 16-bit register space is utilised, the format in which the data is stored is controlled by the ADRFS bit in the ADCR0 register as shown in the accompanying table. D0~D11 are the A/D conversion result data bits. Any unused bits will be read as zero.

ADRF	ADRH								ADRL							
	7	6	5	4	3	2	1	0	7	6	5	4	3	2	1	0
0	D11	D10	D9	D8	D7	D6	D5	D4	D3	D2	D1	D0	0	0	0	0
1	0	0	0	0	D11	D10	D9	D8	D7	D6	D5	D4	D3	D2	D1	D0

A/D Data Registers

**A/D Converter Control Registers –
ADCR0, ADCR1, ACERL**

To control the function and operation of the A/D converter, three control registers known as ADCR0, ADCR1 and ACERL are provided. These 8-bit registers define functions such as the selection of which analog channel is connected to the internal A/D converter, the digitised data format, the A/D clock source as well as controlling the start function and monitoring the A/D converter end of conversion status. The ACS1~ACS0 bits in the ADCR0 register and ACS4 bit in the ADCR1 register define the ADC input channel number. As the device contains only one actual analog to digital converter hardware circuit, each of the individual 4 analog inputs must be routed to the converter. It is the function of the ACS4 and ACS1~ACS0 bits to determine which analog channel input pins or internal 1.25V is actually connected to the internal A/D converter.

The ACERL control register contains the ACER3~ACER0 bits which determine which pins on PA0~PA3 are used as analog inputs for the A/D converter input and which pins are not to be used as the A/D converter input. Setting the corresponding bit high will select the A/D input function, clearing the bit to zero will select either the I/O or other pin-shared function. When the pin is selected to be an A/D input, its original function whether it is an I/O or other pin-shared function will be removed. In addition, any internal pull-high resistors connected to these pins will be automatically removed if the pin is selected to be an A/D input.

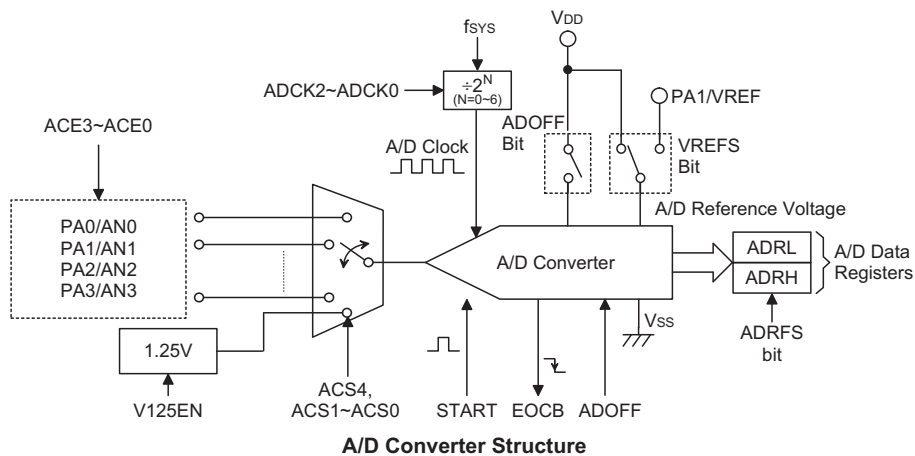

• ADCR0 Register

Bit	7	6	5	4	3	2	1	0
Name	START	EOCB	ADOFF	ADRFS	—	—	ACS1	ACS0
R/W	R/W	R	R/W	R/W	—	—	R/W	R/W
POR	0	1	1	0	—	—	0	0

- Bit 7** **START:** start the A/D conversion
0→1→0 : start
0→1 : reset the A/D converter and set EOCB to "1"
This bit is used to initiate an A/D conversion process. The bit is normally low but if set high and then cleared low again, the A/D converter will initiate a conversion process. When the bit is set high the A/D converter will be reset.
- Bit 6** **EOCB:** End of A/D conversion flag
0: A/D conversion ended
1: A/D conversion in progress
This read only flag is used to indicate when an A/D conversion process has completed. When the conversion process is running the bit will be high.
- Bit 5** **ADOFF :** A/D module power on/off control bit
0: ADC module power on
1: ADC module power off
This bit controls the power to the A/D internal function. This bit should be cleared to zero to enable the A/D converter. If the bit is set high then the A/D converter will be switched off reducing the device power consumption. As the A/D converter will consume a limited amount of power, even when not executing a conversion, this may be an important consideration in power sensitive battery powered applications.
Note: 1. it is recommended to set ADOFF=1 before entering IDLE/SLEEP Mode for saving power.
2. ADOFF=1 will power down the ADC module.
- Bit 4** **ADRFS:** A/D data format control bit
0: ADC Data MSB is ADRH bit 7, LSB is ADRL bit 4
1: ADC Data MSB is ADRH bit 3, LSB is ADRL bit 0
This bit controls the format of the 12-bit converted A/D value in the two A/D data registers. Details are provided in the A/D data register section.
- Bit 3~2** unimplemented, read as "0"
- Bit 1~0** **ACS1, ACS0:** Select A/D channel (when ACS4 is "0")
00: AN0
01: AN1
10: AN2
11: AN3

• **ADCR1 Register**

Bit	7	6	5	4	3	2	1	0
Name	ACS4	V125EN	—	VREFS	—	ADCK2	ADCK1	ADCK0
R/W	R/W	R/W	—	R/W	—	R/W	R/W	R/W
POR	0	0	—	0	—	0	0	0

- Bit 7** **ACS4:** select internal 1.25V as ADC input control
0: disable
1: enable
This bit enables 1.25V to be connected to the A/D converter. The V125EN bit must first have been set to enable the bandgap circuit 1.25V voltage to be used by the A/D converter. When the ACS4 bit is set high, the bandgap 1.25V voltage will be routed to the A/D converter and the other A/D input channels disconnected.
- Bit 6** **V125EN:** internal 1.25V control
0: disable
1: enable
This bit controls the internal Bandgap circuit on/off function to the A/D converter. When the bit is set high the bandgap voltage 1.25V can be used by the A/D converter. If 1.25V is not used by the A/D converter and the LVR/LVD function is disabled then the bandgap reference circuit will be automatically switched off to conserve power. When 1.25V is switched on for use by the A/D converter, a time t_{BG} should be allowed for the bandgap circuit to stabilise before implementing an A/D conversion.
- Bit 5** unimplemented, read as "0"
- Bit 4** **VREFS:** selecte ADC reference voltage
0: internal ADC power
1: VREF pin
This bit is used to select the reference voltage for the A/D converter. If the bit is high, then the A/D converter reference voltage is supplied on the external VREF pin. If the pin is low, then the internal reference is used which is taken from the power supply pin VDD. When the A/D converter reference voltage is supplied on the external VREF pin which is pin-shared with other functions, all of the pin-shared functions except VREF on this pin are disabled.
- Bit 3** unimplemented, read as "0"
- Bit 2~0** **ADCK2, ADCK1, ADCK0:** select ADC clock source
000: f_{SYS}
001: $f_{SYS}/2$
010: $f_{SYS}/4$
011: $f_{SYS}/8$
100: $f_{SYS}/16$
101: $f_{SYS}/32$
110: $f_{SYS}/64$
111: undefined
These three bits are used to select the clock source for the A/D converter.

• ACERL Register

Bit	7	6	5	4	3	2	1	0
Name	—	—	—	—	ACE3	ACE2	ACE1	ACE0
R/W	—	—	—	—	R/W	R/W	R/W	R/W
POR	—	—	—	—	1	1	1	1

Bit 7~4	unimplemented, read as "0"
Bit 3	ACE3: Define PA3 is A/D input or not 0: not A/D input 1: A/D input, AN3
Bit 2	ACE2: Define PA2 is A/D input or not 0: not A/D input 1: A/D input, AN2
Bit 1	ACE1: Define PA1 is A/D input or not 0: not A/D input 1: A/D input, AN1
Bit 0	ACE0: Define PA0 is A/D input or not 0: not A/D input 1: A/D input, AN0

A/D Operation

The START bit in the ADCR0 register is used to start and reset the A/D converter. When the microcontroller sets this bit from low to high and then low again, an analog to digital conversion cycle will be initiated. When the START bit is brought from low to high but not low again, the EOCB bit in the ADCR0 register will be set high and the analog to digital converter will be reset. It is the START bit that is used to control the overall start operation of the internal analog to digital converter.

The EOCB bit in the ADCR0 register is used to indicate when the analog to digital conversion process is complete. This bit will be automatically set to 0 by the microcontroller after a conversion cycle has ended. In addition, the corresponding A/D interrupt request flag will be set in the interrupt control register, and if the interrupts are enabled, an appropriate internal interrupt signal will be generated. This A/D internal interrupt signal will direct the program flow to the associated A/D internal interrupt address for processing. If the A/D internal interrupt is disabled, the microcontroller can be used to poll the EOCB bit in the ADCR0 register to check whether it has been cleared as an alternative method of detecting the end of an A/D conversion cycle.

The clock source for the A/D converter, which originates from the system clock f_{SYS} , can be chosen to be either f_{SYS} or a subdivided version of f_{SYS} . The division ratio value is determined by the ADCK2~ADCK0 bits in the ADCR1 register.

Although the A/D clock source is determined by the system clock f_{SYS} , and by bits ADCK2~ADCK0, there are some limitations on the A/D clock source speed range that can be selected. As the recommended range of permissible A/D clock period, t_{ADCK} , is from 0.5 μ s to 10 μ s, care must be taken for selected system clock frequencies. For example, if the system clock operates at a frequency of 4MHz, the ADCK2~ADCK0 bits should not be set to 000B or 110B. Doing so will give A/D clock periods that are less than the minimum A/D clock period or greater than the maximum A/D clock period which may result in inaccurate A/D conversion values. Refer to the following table for examples, where values marked with an asterisk * show where, depending upon the device, special care must be taken, as the values may be less than the specified minimum A/D Clock Period.

f _{sys}	A/D Clock Period (t _{ADCK})							
	ADCK2, ADCK1, ADCK0 = 000 (f _{sys})	ADCK2, ADCK1, ADCK0 = 001 (f _{sys} /2)	ADCK2, ADCK1, ADCK0 = 010 (f _{sys} /4)	ADCK2, ADCK1, ADCK0 = 011 (f _{sys} /8)	ADCK2, ADCK1, ADCK0 = 100 (f _{sys} /16)	ADCK2, ADCK1, ADCK0 = 101 (f _{sys} /32)	ADCK2, ADCK1, ADCK0 = 110 (f _{sys} /64)	ADCK2, ADCK1, ADCK0 = 111
1MHz	1μs	2μs	4μs	8μs	16μs*	32μs*	64μs*	Undefined
2MHz	500ns	1μs	2μs	4μs	8μs	16μs*	32μs*	Undefined
4MHz	250ns*	500ns	1μs	2μs	4μs	8μs	16μs*	Undefined
8MHz	125ns*	250ns*	500ns	1μs	2μs	4μs	8μs	Undefined
12MHz	83ns*	167ns*	333ns*	667ns	1.33μs	2.67μs	5.33μs	Undefined

A/D Clock Period Examples

Controlling the power on/off function of the A/D converter circuitry is implemented using the ADOFF bit in the ADCR0 register. This bit must be zero to power on the A/D converter. When the ADOFF bit is cleared to zero to power on the A/D converter internal circuitry a certain delay, as indicated in the timing diagram, must be allowed before an A/D conversion is initiated. Even if no pins are selected for use as A/D inputs by clearing the ACE3~ACE0 bits in the ACERL register, if the ADOFF bit is zero then some power will still be consumed. In power conscious applications it is therefore recommended that the ADOFF is set high to reduce power consumption when the A/D converter function is not being used.

The reference voltage supply to the A/D Converter can be supplied from either the positive power supply pin, VDD, or from an external reference sources supplied on pin VREF. The desired selection is made using the VREFS bit. As the VREF pin is pin-shared with other functions, when the VREFS bit is set high, the VREF pin function will be selected and the other pin functions will be disabled automatically.

A/D Input Pins

All of the A/D analog input pins are pin-shared with the I/O pins on PA3~PA0 as well as other functions. The ACE3~ACE0 bits in the ACERL register determines whether the input pins are setup as A/D converter analog inputs or whether they have other functions. If the ACE3~ACE0 bits for its corresponding pin is set high then the pin will be setup to be an A/D converter input and the original pin functions disabled. In this way, pins can be changed under program control to change their function between A/D inputs and other functions. All pull-high resistors, which are setup through register programming, will be automatically disconnected if the pins are setup as A/D inputs. Note that it is not necessary to first setup the A/D pin as an input in the PAC port control register to enable the A/D input as when the ACE3~ACE0 bits enable an A/D input, the status of the port control register will be overridden.

The A/D converter has its own reference voltage pin VREF however the reference voltage can also be supplied from the power supply pin, a choice which is made through the VREFS bit in the ADCR1 register. The analog input values must not be allowed to exceed the value of VREF.

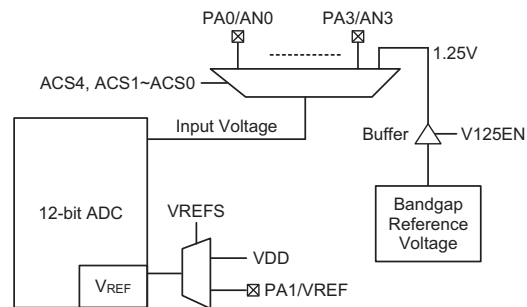

A/D Input Structure

Summary of A/D Conversion Steps

The following summarises the individual steps that should be executed in order to implement an A/D conversion process.

- Step 1
Select the required A/D conversion clock by correctly programming bits ADCK2~ADCK0 in the ADCR1 register.
- Step 2
Enable the A/D by clearing the ADOFF bit in the ADCR0 register to zero.
- Step 3
Select which channel is to be connected to the internal A/D converter by correctly programming the ACS4 and ACS1~ACS0 bits which are also contained in the ADCR1 and ADCR0 registers.
- Step 4
Select which pins are to be used as A/D inputs and configure them by correctly programming the ACE3~ACE0 bits in the ACERL register.

- Step 5
If the interrupts are to be used, the interrupt control registers must be correctly configured to ensure the A/D converter interrupt function is active. The master interrupt control bit, EMI, and the A/D converter interrupt bit, ADE, must both be set to high to do this.
- Step 6
The analog to digital conversion process can now be initialised by setting the START bit in the ADCR0 register from low to high and then to low again. Note that this bit should have been originally cleared to 0.
- Step 7
To check when the analog to digital conversion process is complete, the EOCB bit in the ADCR0 register can be polled. The conversion process is complete when this bit goes low. When this occurs, the A/D data registers ADRL and ADRH can be read to obtain the conversion value. As an alternative method if the interrupts are enabled and the stack is not full, the program can wait for an A/D interrupt to occur.
Note: When checking for the end of the conversion process, if the method of polling the EOCB bit in the ADCR0 register is used, the interrupt enable step above can be omitted.

The accompanying diagram shows graphically the various stages involved in an analog to digital conversion process and its associated timing. After an A/D conversion process has been initiated by the application program, the microcontroller internal hardware will begin to carry out the conversion, during which time the program can continue with other functions. The time taken for the A/D conversion is $16t_{ADCK}$ where t_{ADCK} is equal to the A/D clock period.

Programming Considerations

During microcontroller operates where the A/D converter is not being used, the A/D internal circuitry can be switched off to reduce power consumption, by setting bit ADOFF high in the ADCR0 register. When this happens, the internal A/D converter circuits will not consume power irrespective of what analog voltage is applied to their input lines. If the A/D converter input lines are used as normal I/Os, then care must be taken as if the input voltage is not at a valid logic level, then this may lead to some increase in power consumption.

The power-on reset condition of the A/D converter control registers will ensure that the shared function pins are setup as A/D converter inputs. If any of the A/D converter input pins are to be used for functions, then the A/D converter control register bits must be properly setup to disable the A/D input configuration.

A/D Transfer Function

As the devices contain a 12-bit A/D converter, its full-scale converted digitised value is equal to FFFH. Since the full-scale analog input value is equal to the V_{DD} or V_{REF} voltage, this gives a single bit analog input value of V_{DD} or V_{REF} divided by 4096.

$$1 \text{ LSB} = (V_{DD} \text{ or } V_{REF}) \div 4096$$

The A/D Converter input voltage value can be calculated using the following equation:

A/D input voltage =

$$\text{A/D output digital value} \times (V_{DD} \text{ or } V_{REF}) \div 4096$$

The diagram shows the ideal transfer function between the analog input value and the digitised output value for the A/D converter. Except for the digitised zero value, the subsequent digitised values will change at a point 0.5 LSB below where they would change without the offset, and the last full scale digitised value will change at a point 1.5 LSB below the V_{DD} or V_{REF} level.

A/D Programming Example

The following two programming examples illustrate how to setup and implement an A/D conversion. In the first example, the method of polling the EOCB bit in the ADCR0 register is used to detect when the conversion cycle is complete, whereas in the second example, the A/D interrupt is used to determine when the conversion is complete.

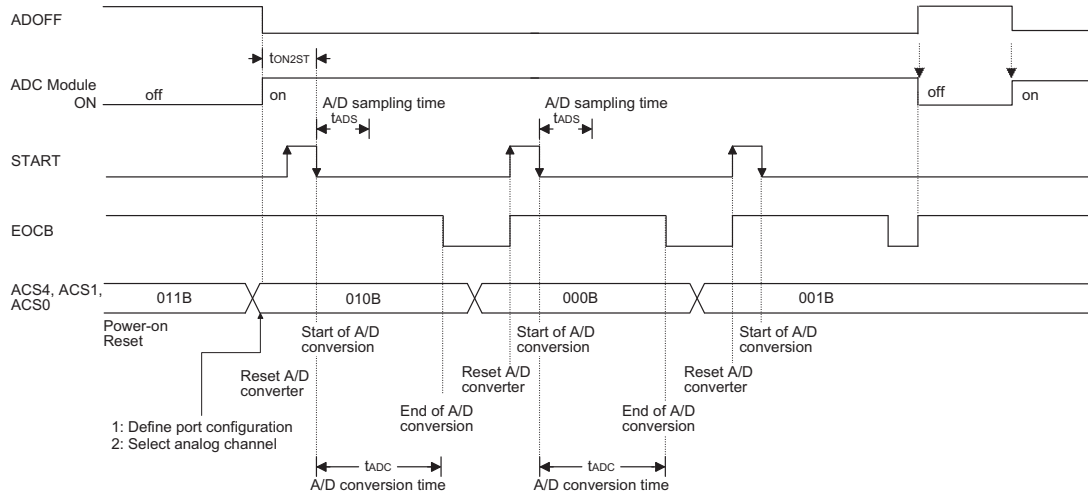

A/D Conversion Timing

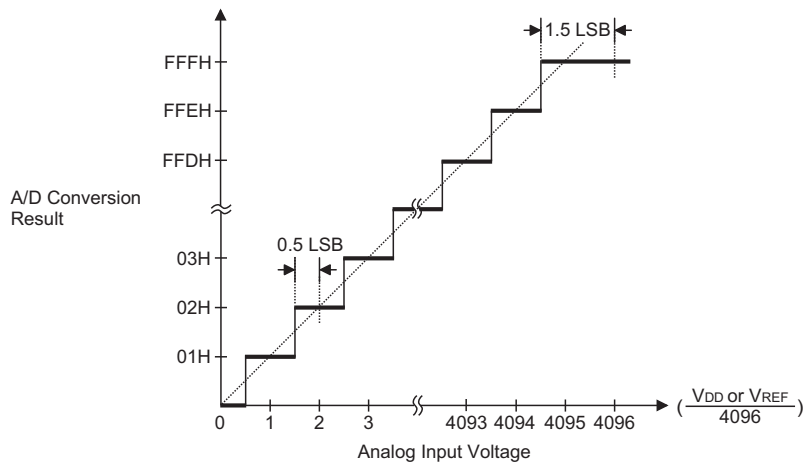

Ideal A/D Transfer Function

Example: using an EOCB polling method to detect the end of conversion

```

clr ADE ; disable ADC interrupt
mov a,03H
mov ADCR1,a ; select fsys/8 as A/D clock and switch off 1.25V
clr ADOFF
mov a,0Fh ; setup ACERL to configure pins AN0~AN3
mov ACERL,a
mov a,00h
mov ADCR0,a ; enable and connect AN0 channel to A/D converter
:
start_conversion:
clr START ; high pulse on start bit to initiate conversion
set START ; reset A/D
clr START ; start A/D
polling_EOC:
sz EOCB ; poll the ADCR0 register EOCB bit to detect end
; of A/D conversion
jmp polling_EOC ; continue polling
mov a,ADRL ; read low byte conversion result value
mov ADRL_buffer,a ; save result to user defined register
mov a,ADRH ; read high byte conversion result value
mov ADRH_buffer,a ; save result to user defined register
:
:
jmp start_conversion ; start next a/d conversion

```

Example: using the interrupt method to detect the end of conversion

```

clr ADE ; disable ADC interrupt
mov a,03H
mov ADCR1,a ; select fsys/8 as A/D clock and switch off 1.25V
Clr ADOFF
mov a,0Fh ; setup ACERL to configure pins AN0~AN3
mov ACERL,a
mov a,00h
mov ADCR0,a ; enable and connect AN0 channel to A/D converter
Start_conversion:
clr START ; high pulse on START bit to initiate conversion
set START ; reset A/D
clr START ; start A/D
clr ADF ; clear ADC interrupt request flag
set ADE ; enable ADC interrupt
set EMI ; enable global interrupt
:
:
; ADC interrupt service routine
ADC_ISR:
mov acc_stack,a ; save ACC to user defined memory
mov a,STATUS
mov status_stack,a ; save STATUS to user defined memory
:
:
mov a,ADRL ; read low byte conversion result value
mov adrl_buffer,a ; save result to user defined register
mov a,ADRH ; read high byte conversion result value
mov adrh_buffer,a ; save result to user defined register
:
:
EXIT_INT_ISR:
mov a,status_stack
mov STATUS,a ; restore STATUS from user defined memory
mov a,acc_stack ; restore ACC from user defined memory
reti

```

Comparators

An analog comparator is contained within these devices. These functions offer flexibility via their register controlled features such as power-down, polarity select, hysteresis etc. In sharing their pins with normal I/O pins the comparators do not waste precious I/O pins if these functions are otherwise unused.

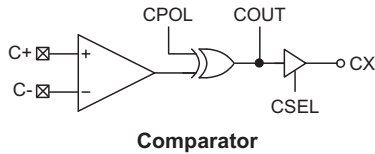

Comparator

Comparator Operation

The device contains a comparator function which is used to compare two analog voltages and provide an output based on their difference. Full control over the internal comparators is provided via the control register CPC assigned to the comparator. The comparator output is recorded via a bit in the control register, but can also be transferred out onto a shared I/O pin. Additional comparator functions include, output polarity, hysteresis functions and power down control.

Any pull-high resistors connected to the shared comparator input pins will be automatically disconnected when the comparator is enabled. As the comparator inputs approach their switching level, some spurious output signals may be generated on the comparator output due to the slow rising or falling nature of the input signals. This can be minimised by selecting the hysteresis function will apply a small amount of positive feedback to the comparator. Ideally the comparator should switch at the point where the positive and negative inputs signals are at the same voltage level, however, unavoidable input offsets introduce some uncertainties here. The hysteresis function, if enabled, also increases the switching offset value.

Comparator Interrupt

The comparator possesses its own interrupt function. When the comparator output changes state, its relevant interrupt flag will be set, and if the corresponding interrupt enable bit is set, then a jump to its relevant interrupt vector will be executed. Note that it is the changing state of the COUT bit and not the output pin which generates an interrupt. If the microcontroller is in the SLEEP or IDLE Mode and the Comparator is enabled, then if the external input lines cause the Comparator output to change state, the resulting generated interrupt flag will also generate a wake-up. If it is required to disable a wake-up from occurring, then the interrupt flag should be first set high before entering the SLEEP or IDLE Mode.

Programming Considerations

If the comparator is enabled, it will remain active when the microcontroller enters the SLEEP or IDLE Mode, however as it will consume a certain amount of power, the user may wish to consider disabling it before the SLEEP or IDLE Mode is entered.

As comparator pins are shared with normal I/O pins the I/O registers for these pins will be read as zero (port control register is "1") or read as port data register value (port control register is "0") if the comparator function is enabled.

• CPC Register

Bit	7	6	5	4	3	2	1	0
Name	CSEL	CEN	CPOL	COUT	COS	—	—	CHYEN
R/W	R/W	R/W	R/W	R	R/W	—	—	R/W
POR	1	0	0	0	0	—	—	1

- Bit 7** **CSEL:** Select Comparator pins or I/O pins
0: I/O pin select
1: Comparator pin select
This is the Comparator pin or I/O pin select bit. If the bit is high the comparator will be selected and the two comparator input pins will be enabled. As a result, these two pins will lose their I/O pin functions. Any pull-high configuration options associated with the comparator shared pins will also be automatically disconnected.
- Bit 6** **CEN:** Comparator On/Off control
0: Off
1: On
This is the Comparator on/off control bit. If the bit is zero the comparator will be switched off and no power consumed even if analog voltages are applied to its inputs. For power sensitive applications this bit should be cleared to zero if the comparator is not used or before the device enters the SLEEP or IDLE mode.
- Bit 5** **CPOL:** Comparator output polarity
0: output not inverted
1: output inverted
This is the comparator polarity bit. If the bit is zero then the COUT bit will reflect the non-inverted output condition of the comparator. If the bit is high the comparator COUT bit will be inverted.
- Bit 4** **COUT:** Comparator output bit
CPOL=0
0: C+ < C-
1: C+ > C-
CPOL=1
0: C+ > C-
1: C+ < C-
This bit stores the comparator output bit. The polarity of the bit is determined by the voltages on the comparator inputs and by the condition of the CPOL bit.
- Bit 3** **COS:** Output path select
0: CX pin
1: Internal use
This is the comparator output path select control bit. If the bit is set to "0" and the CSEL bit is "1" the comparator output is connected to an external CX pin. If the bit is set to "1" or the CSEL bit is "0" the comparator output signal is only used internally by the device allowing the shared comparator output pin to retain its normal I/O operation.
- Bit 2~1** unimplemented, read as "0"
- Bit 0** **CHYEN:** Hysteresis Control
0: Off
1: On
This is the hysteresis control bit and if set high will apply a limited amount of hysteresis to the comparator, as specified in the Comparator Electrical Characteristics table. The positive feedback induced by hysteresis reduces the effect of spurious switching near the comparator threshold.

Interrupts

Interrupts are an important part of any microcontroller system. When an external event or an internal function such as a Timer Module or an A/D converter requires microcontroller attention, their corresponding interrupt will enforce a temporary suspension of the main program allowing the microcontroller to direct attention to their respective needs. The device contains several external interrupt and internal interrupts functions. The external interrupt is generated by the action of the external INT pin, while the internal interrupts are generated by various internal functions such as the TMs, Comparator, Time Base, LVD, EEPROM, SIM and the A/D converter.

Interrupt Registers

Overall interrupt control, which basically means the setting of request flags when certain microcontroller conditions occur and the setting of interrupt enable bits by the application program, is controlled by a series of registers, located in the Special Purpose Data Memory, as shown in the accompanying table. The number of registers depends upon the device chosen but fall into three categories. The first is the INTC0~INTC2 registers which setup the primary interrupts, the second is the MF10~MF12 registers which setup the Multi-function interrupts. Finally there is an INTEG register to setup the external interrupt trigger edge type.

Each register contains a number of enable bits to enable or disable individual interrupts as well as interrupt flags to indicate the presence of an interrupt request. The naming convention of these follows a specific pattern. First is listed an abbreviated interrupt type, then the (optional) number of that interrupt followed by either an "E" for enable/ disable bit or "F" for request flag.

Function	Enable Bit	Request Flag	Notes
Global	EMI	—	—
INTn Pin	INTnE	INTnF	n=0~1
Comparator	CPE	CPF	—
Multi-function	MFnE	MFnF	n=0~2
A/D Converter	ADE	ADF	HT66F016, HT66F017 only
Time Base	TBnE	TBnF	n=0~1
LVD	LVE	LVF	—
EEPROM	DEE	DEF	—
TM	TnPE	TnPF	n=0~1
	TnAE	TnAF	

Interrupt Register Bit Naming Conventions

• HT66F016, HT68F016 Interrupt Register Contents

Name	Bit							
	7	6	5	4	3	2	1	0
INTEG	—	—	—	—	INT1S1	INT1S0	INT0S1	INT0S0
INTC0	—	—	CPF	INT0F	—	CPE	INT0E	EMI
INTC1	TB0F	ADF	MF2F	MF1F	TB0E	ADE	MF2E	MF1E
INTC2	—	—	INT1F	TB1F	—	—	INT1E	TB1E
MF10	—	—	—	—	—	—	—	—
MF11	—	—	T1AF	T1PF	—	—	T1AE	T1PE
MF12	—	—	DEF	LVF	—	—	DEE	LVE

Note: HT68F016 doesn't have ADE & ADF bits

• HT66F017, HT68F017 Interrupt Register Contents

Name	Bit							
	7	6	5	4	3	2	1	0
INTEG	—	—	—	—	INT1S1	INT1S0	INT0S1	INT0S0
INTC0	—	MF0F	CPF	INT0F	MF0E	CPE	INT0E	EMI
INTC1	TB0F	ADF	MF2F	MF1F	TB0E	ADE	MF2E	MF1E
INTC2	—	—	INT1F	TB1F	—	—	INT1E	TB1E
MF01	—	—	T0AF	T0PF	—	—	T0AE	T0PE
MF11	—	—	T1AF	T1PF	—	—	T1AE	T1PE
MF12	—	—	DEF	LVF	—	—	DEE	LVE

Note: HT68F017 doesn't have ADE & ADF bits

• **INTEG Register**

Bit	7	6	5	4	3	2	1	0
Name	—	—	—	—	INT1S1	INT1S0	INT0S1	INT0S0
R/W	—	—	—	—	R/W	R/W	R/W	R/W
POR	—	—	—	—	0	0	0	0

- Bit 7~2 unimplemented, read as "0"
- Bit 3~2 **INT1S1~INT1S0**: interrupt edge control for INT1 pin
 00: disable
 01: rising edge
 10: falling edge
 01: both rising and falling edges
- Bit 1~0 **INT0S1~INT0S0**: interrupt edge control for INT0 pin
 00: disable
 01: rising edge
 10: falling edge
 01: both rising and falling edges

• **INTC0 Register**

Bit	7	6	5	4	3	2	1	0
Name	—	MF0F	CPF	INT0F	MF0E	CPE	INT0E	EMI
R/W	—	R/W	R/W	R/W	R/W	R/W	R/W	R/W
POR	—	0	0	0	0	0	0	0

- Note: HT66F016 , HT68F016 & HT68F017 don't have MF0E, MF0F
- Bit 7 unimplemented, read as "0"
- Bit 6 **MF0F**: Multi-function 0 Interrupt Request Flag
 0: no request
 1: interrupt request
- Bit 5 **CPF**: Comparator interrupt request flag
 0: no request
 1: interrupt request
- Bit 4 **INT0F**: INT0 pin interrupt request flag
 0: no request
 1: interrupt request
- Bit 3 **MF0E**: Multi-function 0 Interrupt Control
 0: disable
 1: enable
- Bit 2 **CPE**: Comparator interrupt control
 0: disable
 1: enable
- Bit 1 **INT0E**: INT0 interrupt control
 0: disable
 1: enable
- Bit 0 **EMI**: Global interrupt control
 0: disable
 1: enable

• **INTC1 Register**

Bit	7	6	5	4	3	2	1	0
Name	TB0F	ADF	MF2F	MF1F	TB0E	ADE	MF2E	MF1E
R/W	R/W	R/W	R/W	R/W	R/W	R/W	R/W	R/W
POR	0	0	0	0	0	0	0	0

Note: HT68F016, HT68F017 don't have ADE, ADF

- Bit 7 **TB0F**: Time Base 0 Interrupt Request Flag
0: no request
1: interrupt request
- Bit 6 **ADF**: A/D Converter Interrupt Request Flag
0: no request
1: interrupt request
- Bit 5 **MF2F**: Multi-function Interrupt 2 Request Flag
0: no request
1: interrupt request
- Bit 4 **MF1F**: Multi-function Interrupt 1 Request Flag
0: no request
1: interrupt request
- Bit 3 **TB0E**: Time Base 0 Interrupt Control
0: disable
1: enable
- Bit 2 **ADE**: A/D converter interrupt control
0: disable
1: enable
- Bit 1 **MF2E**: Multi-function Interrupt 2 Control
0: disable
1: enable
- Bit 0 **MF1E**: Multi-function Interrupt 1 Control
0: disable
1: enable

• **INTC2 Register**

Bit	7	6	5	4	3	2	1	0
Name	—	—	INT1F	TB1F	—	—	INT1E	TB1E
R/W	—	—	R/W	R/W	—	—	R/W	R/W
POR	—	—	0	0	—	—	0	0

- Bit 7~6 unimplemented, read as "0"
- Bit 5 **INT1F**: INT1 pin interrupt request flag
0: no request
1: interrupt request
- Bit 4 **TB1F**: Time Base 1 Interrupt Request Flag
0: no request
1: interrupt request
- Bit 3~2 unimplemented, read as "0"
- Bit 1 **INT1E**: INT1 pin interrupt control
0: disable
1: enable
- Bit 0 **TB1E**: Time Base 1 Interrupt Control
0: disable
1: enable

• **MF10 Register -- HT66F017**

Bit	7	6	5	4	3	2	1	0
Name	—	—	T0AF	T0PF	—	—	T0AE	T0PE
R/W	—	—	R/W	R/W	—	—	R/W	R/W
POR	—	—	0	0	—	—	0	0

- Bit 7~6 unimplemented, read as "0"
- Bit 5 **T0AF**: TM0 Comparator A match interrupt request flag
0: no request
1: interrupt request
- Bit 4 **T0PF**: TM0 Comparator P match interrupt request flag
0: no request
1: interrupt request
- Bit 3~2 unimplemented, read as "0"
- Bit 1 **T0AE**: TM0 Comparator A match interrupt control
0: disable
1: enable
- Bit 0 **T0PE**: TM0 Comparator P match interrupt control
0: disable
1: enable

• **MF11 Register**

Bit	7	6	5	4	3	2	1	0
Name	—	—	T1AF	T1PF	—	—	T1AE	T1PE
R/W	—	—	R/W	R/W	—	—	R/W	R/W
POR	—	—	0	0	—	—	0	0

- Bit 7~6 unimplemented, read as "0"
- Bit 5 **T1AF**: TM1 Comparator A match interrupt request flag
0: no request
1: interrupt request
- Bit 4 **T1PF**: TM1 Comparator P match interrupt request flag
0: no request
1: interrupt request
- Bit 3~2 unimplemented, read as "0"
- Bit 1 **T1AE**: TM1 Comparator A match interrupt control
0: disable
1: enable
- Bit 0 **T1PE**: TM1 Comparator P match interrupt control
0: disable
1: enable

• MF12 Register

Bit	7	6	5	4	3	2	1	0
Name	—	—	DEF	LVF	—	—	DEE	LVE
R/W	—	—	R/W	R/W	—	—	R/W	R/W
POR	—	—	0	0	—	—	0	0

Bit 7~6	unimplemented, read as "0"
Bit 5	DEF: Data EEPROM interrupt request flag 0: No request 1: Interrupt request
Bit 4	LVF: LVD interrupt request flag 0: No request 1: Interrupt request
Bit 3~2	unimplemented, read as "0"
Bit 1	DEE: Data EEPROM Interrupt Control 0: Disable 1: Enable
Bit 0	LVE: LVD Interrupt Control 0: Disable 1: Enable

Interrupt Operation

When the conditions for an interrupt event occur, such as a TM Comparator P or Comparator A match or A/D conversion completion etc, the relevant interrupt request flag will be set. Whether the request flag actually generates a program jump to the relevant interrupt vector is determined by the condition of the interrupt enable bit. If the enable bit is set high then the program will jump to its relevant vector; if the enable bit is zero then although the interrupt request flag is set an actual interrupt will not be generated and the program will not jump to the relevant interrupt vector. The global interrupt enable bit, if cleared to zero, will disable all interrupts.

When an interrupt is generated, the Program Counter, which stores the address of the next instruction to be executed, will be transferred onto the stack. The Program Counter will then be loaded with a new address which will be the value of the corresponding interrupt vector. The microcontroller will then fetch its next instruction from this interrupt vector. The instruction at this vector will usually be a "JMP" which will jump to another section of program which is known as the interrupt service routine. Here is located the code to control the appropriate interrupt. The interrupt service routine must be terminated with a "RETI", which retrieves the original Program Counter address from the stack and allows the microcontroller to continue with normal execution at the point where the interrupt occurred.

The various interrupt enable bits, together with their associated request flags, are shown in the accompanying diagrams with their order of priority. Some interrupt sources have their own individual vector while others share the same multi-function interrupt vector. Once an interrupt subroutine is serviced, all the other interrupts will be blocked, as the global interrupt enable bit, EMI bit will be cleared automatically. This will prevent any further interrupt nesting from occurring. However, if other interrupt requests occur during this interval, although the interrupt will not be immediately serviced, the request flag will still be recorded.

If an interrupt requires immediate servicing while the program is already in another interrupt service routine, the EMI bit should be set after entering the routine, to allow interrupt nesting. If the stack is full, the interrupt request will not be acknowledged, even if the related interrupt is enabled, until the Stack Pointer is decremented. If immediate service is desired, the stack must be prevented from becoming full. In case of simultaneous requests, the accompanying diagram shows the priority that is applied. All of the interrupt request flags when set will wake-up the device if it is in SLEEP or IDLE Mode, however to prevent a wake-up from occurring the corresponding flag should be set before the device is in SLEEP or IDLE Mode.

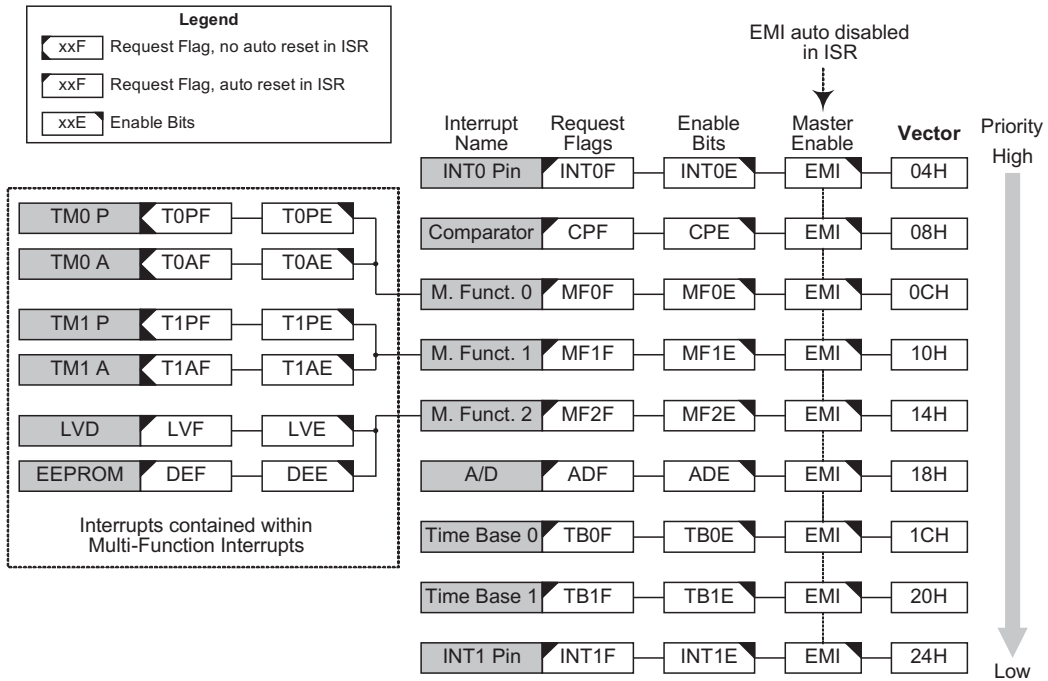

Note: HT68F017 don't have ADE, ADF

Interrupt Structure – HT66F017/HT68F017

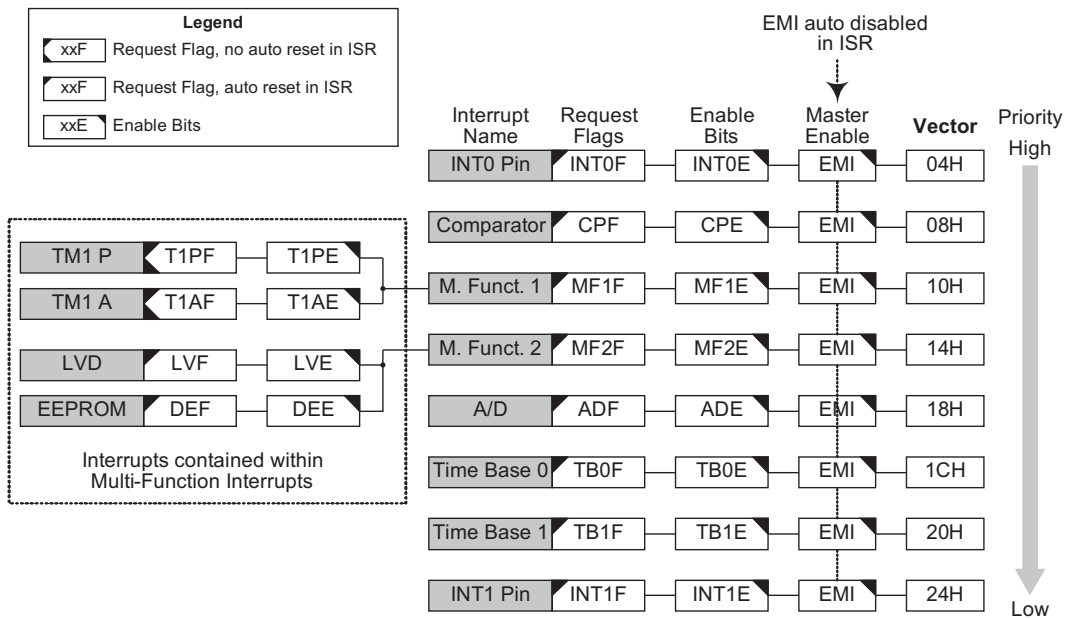

Note: HT68F016 don't have ADE, ADF

Interrupt Structure – HT66F016/HT68F016

External Interrupt

The external interrupts are controlled by signal transitions on the INT0~INT1 pins. An external interrupt request will take place when the external interrupt request flags, INT0F~INT1F, are set, which will occur when a transition, whose type is chosen by the edge select bits, appears on the external interrupt pins. To allow the program to branch to its respective interrupt vector address, the global interrupt enable bit, EMI, and respective external interrupt enable bit, INT0E~INT1E, must first be set. Additionally the correct interrupt edge type must be selected using the INTEG register to enable the external interrupt function and to choose the trigger edge type. As the external interrupt pins are pin-shared with I/O pins, they can only be configured as external interrupt pins if their external interrupt enable bit in the corresponding interrupt register has been set. The pin must also be setup as an input by setting the corresponding bit in the port control register. When the interrupt is enabled, the stack is not full and the correct transition type appears on the external interrupt pin, a subroutine call to the external interrupt vector, will take place. When the interrupt is serviced, the external interrupt request flags, INT0F~INT1F, will be automatically reset and the EMI bit will be automatically cleared to disable other interrupts. Note that any pull-high resistor selections on the external interrupt pins will remain valid even if the pin is used as an external interrupt input.

The INTEG register is used to select the type of active edge that will trigger the external interrupt. A choice of either rising or falling or both edge types can be chosen to trigger an external interrupt. Note that the INTEG register can also be used to disable the external interrupt function.

Comparator Interrupt

The comparator interrupt is controlled by the internal comparator. A comparator interrupt request will take place when the comparator interrupt request flag, CPF, is set, a situation that will occur when the comparator output changes state. To allow the program to branch to its respective interrupt vector address, the global interrupt enable bit, EMI, and comparator interrupt enable bit, CPE, must first be set. When the interrupt is enabled, the stack is not full and the comparator inputs generate a comparator output transition, a subroutine call to the comparator interrupt vector, will take place. When the interrupt is serviced, the comparator interrupt request flag, will be automatically reset and the EMI bit will be automatically cleared to disable other interrupts.

Multi-function Interrupt

Within these devices there are up to three Multi-function interrupts. Unlike the other independent interrupts, these interrupts have no independent source, but rather are formed from other existing interrupt sources, namely the TM Interrupts, LVD interrupt and EEPROM interrupt.

A Multi-function interrupt request will take place when any of the Multi-function interrupt request flags, MFnF are set. The Multi-function interrupt flags will be set when any of their included functions generate an interrupt request flag. To allow the program to branch to its respective interrupt vector address, when the Multi-function interrupt is enabled and the stack is not full, and either one of the interrupts contained within each of Multi-function interrupt occurs, a subroutine call to one of the Multi-function interrupt vectors will take place. When the interrupt is serviced, the related Multi-Function request flag, will be automatically reset and the EMI bit will be automatically cleared to disable other interrupts.

However, it must be noted that, although the Multi-function Interrupt flags will be automatically reset when the interrupt is serviced, the request flags from the original source of the Multi-function interrupts, namely the TM Interrupts, LVD interrupt and EEPROM interrupt, will not be automatically reset and must be manually reset by the application program.

A/D Converter Interrupt

The A/D Converter Interrupt is controlled by the termination of an A/D conversion process. An A/D Converter Interrupt request will take place when the A/D Converter Interrupt request flag, ADF, is set, which occurs when the A/D conversion process finishes. To allow the program to branch to its respective interrupt vector address, the global interrupt enable bit, EMI, and A/D Interrupt enable bit, ADE, must first be set. When the interrupt is enabled, the stack is not full and the A/D conversion process has ended, a subroutine call to the A/D Converter Interrupt vector, will take place. When the interrupt is serviced, the A/D Converter Interrupt flag, ADF, will be automatically cleared. The EMI bit will also be automatically cleared to disable other interrupts.

Time Base Interrupts

The function of the Time Base Interrupts is to provide regular time signal in the form of an internal interrupt. They are controlled by the overflow signals from their respective timer functions. When these happens their respective interrupt request flags, TB0F or TB1F will be set. To allow the program to branch to their respective interrupt vector addresses, the global interrupt enable bit, EMI and Time Base enable bits, TB0E or TB1E, must first be set. When the interrupt is enabled, the stack is not full and the Time Base overflows, a subroutine call to their respective vector locations will take place. When the interrupt is serviced, the respective interrupt request flag, TB0F or TB1F, will be automatically reset and the EMI bit will be cleared to disable other interrupts.

The purpose of the Time Base Interrupt is to provide an interrupt signal at fixed time periods. Their clock sources originate from the internal clock source f_{TB} . This f_{TB} input clock passes through a divider, the division ratio of which is selected by programming the appropriate bits in the TBC register to obtain longer interrupt periods whose value ranges. The clock source that generates f_{TB} , which in turn controls the Time Base interrupt period, can originate from several different sources, as shown in the System Operating Mode section.

• TBC Register

Bit	7	6	5	4	3	2	1	0
Name	TBON	TBCK	TB11	TB10	—	TB02	TB01	TB00
R/W	R/W	R/W	R/W	R/W	—	R/W	R/W	R/W
POR	0	0	1	1	—	1	1	1

- Bit 7 **TBON**: Time Base control
0: disable
1: enable
- Bit 6 **TBCK**: Time Base clock f_{TB} selection
0: f_{TBC}
1: $f_{SYS}/4$
- Bit 5~4 **TB11~TB10**: select Time Base 1 Time-out period
00: $4096/f_{TB}$
01: $8192/f_{TB}$
10: $16384/f_{TB}$
11: $32768/f_{TB}$
- Bit 3 Unimplemented, read as 0
- Bit 2~0 **TB02~TB00**: select Time Base 0 Time-out period
000: $256/f_{TB}$
001: $512/f_{TB}$
010: $1024/f_{TB}$
011: $2048/f_{TB}$
100: $4096/f_{TB}$
101: $8192/f_{TB}$
110: $16384/f_{TB}$
111: $32768/f_{TB}$

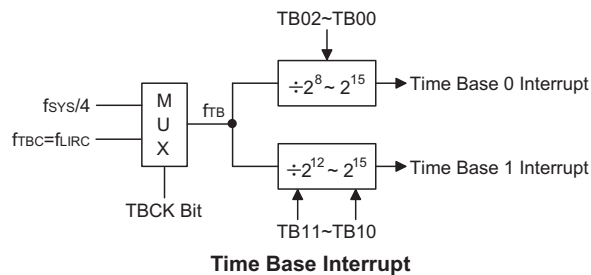

EEPROM Interrupt

The EEPROM Interrupt, is contained within the Multi-function Interrupt. An EEPROM Interrupt request will take place when the EEPROM Interrupt request flag, DEF, is set, which occurs when an EEPROM Write cycle ends. To allow the program to branch to its respective interrupt vector address, the global interrupt enable bit, EMI, EEPROM Interrupt enable bit, DEE, and associated Multi-function interrupt enable bit, must first be set. When the interrupt is enabled, the stack is not full and an EEPROM Write cycle ends, a subroutine call to the respective Multi-function Interrupt vector, will take place. When the EEPROM Interrupt is serviced, the EMI bit will be automatically cleared to disable other interrupts, however only the Multi-function interrupt request flag will be also automatically cleared. As the DEF flag will not be automatically cleared, it has to be cleared by the application program.

LVD Interrupt

The Low Voltage Detector Interrupt is contained within the Multi-function Interrupt. An LVD Interrupt request will take place when the LVD Interrupt request flag, LVF, is set, which occurs when the Low Voltage Detector function detects a low power supply voltage. To allow the program to branch to its respective interrupt vector address, the global interrupt enable bit, EMI, Low Voltage Interrupt enable bit, LVE, and associated Multi-function interrupt enable bit, must first be set. When the interrupt is enabled, the stack is not full and a low voltage condition occurs, a subroutine call to the Multi-function Interrupt vector, will take place. When the Low Voltage Interrupt is serviced, the EMI bit will be automatically cleared to disable other interrupts, however only the Multi-function interrupt request flag will be also automatically cleared. As the LVF flag will not be automatically cleared, it has to be cleared by the application program.

TM Interrupts

The Compact and Standard Type TMs have two interrupts each. All of the TM interrupts are contained within the Multi-function Interrupts. For each of the Compact and Standard Type TMs there are two interrupt request flags TnPF and TnAF and two enable bits TnPE and TnAE. A TM interrupt request will take place when any of the TM request flags are set, a situation which occurs when a TM comparator P or A match situation happens.

To allow the program to branch to its respective interrupt vector address, the global interrupt enable bit, EMI, respective TM Interrupt enable bit, and relevant Multi-function Interrupt enable bit, MFnE, must first be set. When the interrupt is enabled, the stack is not full and a TM comparator match situation occurs, a subroutine call to the relevant Multi-function Interrupt vector locations, will take place. When the TM interrupt is serviced, the EMI bit will be automatically cleared to disable other interrupts, however only the related MFnF flag will be automatically cleared. As the TM interrupt request flags will not be automatically cleared, they have to be cleared by the application program.

Interrupt Wake-up Function

Each of the interrupt functions has the capability of waking up the microcontroller when in the SLEEP or IDLE Mode. A wake-up is generated when an interrupt request flag changes from low to high and is independent of whether the interrupt is enabled or not. Therefore, even though the device is in the SLEEP or IDLE Mode and its system oscillator stopped, situations such as external edge transitions on the external interrupt pins, a low power supply voltage or comparator input change may cause their respective interrupt flag to be set high and consequently generate an interrupt. Care must therefore be taken if spurious wake-up situations are to be avoided. If an interrupt wake-up function is to be disabled then the corresponding interrupt request flag should be set high before the device enters the SLEEP or IDLE Mode. The interrupt enable bits have no effect on the interrupt wake-up function.

Programming Considerations

By disabling the relevant interrupt enable bits, a requested interrupt can be prevented from being serviced, however, once an interrupt request flag is set, it will remain in this condition in the interrupt register until the corresponding interrupt is serviced or until the request flag is cleared by the application program.

Where a certain interrupt is contained within a Multi-function interrupt, then when the interrupt service routine is executed, as only the Multi-function interrupt request flags, MFnF, will be automatically cleared, the individual request flag for the function needs to be cleared by the application program.

It is recommended that programs do not use the "CALL" instruction within the interrupt service subroutine. Interrupts often occur in an unpredictable manner or need to be serviced immediately. If only one stack is left and the interrupt is not well controlled, the original control sequence will be damaged once a CALL subroutine is executed in the interrupt subroutine.

Every interrupt has the capability of waking up the microcontroller when it is in SLEEP or IDLE Mode, the wake up being generated when the interrupt request flag changes from low to high. If it is required to prevent a certain interrupt from waking up the microcontroller then its respective request flag should be first set high before enter SLEEP or IDLE Mode.

As only the Program Counter is pushed onto the stack, then when the interrupt is serviced, if the contents of the accumulator, status register or other registers are altered by the interrupt service program, their contents should be saved to the memory at the beginning of the interrupt service routine.

To return from an interrupt subroutine, either a RET or RETI instruction may be executed. The RETI instruction in addition to executing a return to the main program also automatically sets the EMI bit high to allow further interrupts. The RET instruction however only executes a return to the main program leaving the EMI bit in its present zero state and therefore disabling the execution of further interrupts.

Low Voltage Detector – LVD

Each device has a Low Voltage Detector function, also known as LVD. This enabled the device to monitor the power supply voltage, V_{DD} , and provide a warning signal should it fall below a certain level. This function may be especially useful in battery applications where the supply voltage will gradually reduce as the battery ages, as it allows an early warning battery low signal to be generated. The Low Voltage Detector also has the capability of generating an interrupt signal.

LVD Register

The Low Voltage Detector function is controlled using a single register with the name LVDC. Three bits in this register, VLVD2~VLVD0, are used to select one of eight

fixed voltages below which a low voltage condition will be determined. A low voltage condition is indicated when the LVDO bit is set. If the LVDO bit is low, this indicates that the V_{DD} voltage is above the preset low voltage value. The LVDEN bit is used to control the overall on/off function of the low voltage detector. Setting the bit high will enable the low voltage detector. Clearing the bit to zero will switch off the internal low voltage detector circuits. As the low voltage detector will consume a certain amount of power, it may be desirable to switch off the circuit when not in use, an important consideration in power sensitive battery powered applications.

• LVDC Register

Bit	7	6	5	4	3	2	1	0
Name	—	—	LVDO	LVDEN	—	VLVD2	VLVD1	VLVD0
R/W	—	—	R	R/W	—	R/W	R/W	R/W
POR	—	—	0	0	—	0	0	0

Bit 7~6 unimplemented, read as "0"

Bit 5 **LVDO**: LVD output flag
0: no low voltage detect
1: low voltage detect

Bit **LVDEN**: low voltage detector control
0: disable
1: enable

Bit 3 unimplemented, read as "0"

Bit 2~0 **VLVD2 ~ VLVD0**: select LVD voltage
000: 2.0V
001: 2.2V
010: 2.4V
011: 2.7V
100: 3.0V
101: 3.3V
110: 3.6V
111: 4.2V

LVD Operation

The Low Voltage Detector function operates by comparing the power supply voltage, V_{DD} , with a pre-specified voltage level stored in the LVDC register. This has a range of between 2.0V and 4.2V. When the power supply voltage, V_{DD} , falls below this pre-determined value, the LVDO bit will be set high indicating a low power supply voltage condition. The Low Voltage Detector function is supplied by a reference voltage which will be automatically enabled. When the device is powered down the low voltage detector will remain active if the LVDEN bit is high. After enabling the Low Voltage Detector, a time delay t_{LVDS} should be allowed for the circuitry to stabilise before reading the LVDO bit. Note also that as the V_{DD} voltage may rise and fall rather slowly, at the voltage nears that of V_{LVD} , there may be multiple bit LVDO transitions.

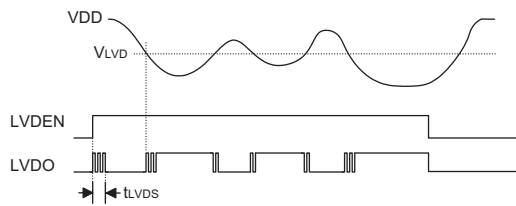

LVD Operation

The Low Voltage Detector also has its own interrupt which is contained within one of the Multi-function interrupts, providing an alternative means of low voltage detection, in addition to polling the LVDO bit. The interrupt will only be generated after a delay of t_{LVD} after the LVDO bit has been set high by a low voltage condition. When the device is powered down the Low Voltage Detector will remain active if the LVDEN bit is high. In this case, the LVF interrupt request flag will be set, causing an interrupt to be generated if V_{DD} falls below the preset LVD voltage. This will cause the device to wake-up from the SLEEP or IDLE Mode, however if the Low Voltage Detector wake up function is not required then the LVF flag should be first set high before the device enters the SLEEP or IDLE Mode.

Configuration Options

Configuration options refer to certain options within the MCU that are programmed into the device during the programming process. During the development process, these options are selected using the HT-IDE software development tools. As these options are programmed into the device using the hardware programming tools, once they are selected they cannot be changed later using the application program. All options must be defined for proper system function, the details of which are shown in the table.

No.	Options
Oscillator Options	
1	High Speed System Oscillator Selection - f_{OSC} : HIRC or HXT
Reset Pin Options	
2	PA7/RES Pin Options: 1. RES pin 2. I/O pin
Watchdog Options	
3	WDT function: Always enable or By S/W control

Application Circuits



Note: "" Recommended component for added ESD protection.

"" Recommended component in environments where power line noise is significant.

Instruction Set

Introduction

Central to the successful operation of any microcontroller is its instruction set, which is a set of program instruction codes that directs the microcontroller to perform certain operations. In the case of Holtek microcontroller, a comprehensive and flexible set of over 60 instructions is provided to enable programmers to implement their application with the minimum of programming overheads.

For easier understanding of the various instruction codes, they have been subdivided into several functional groupings.

Instruction Timing

Most instructions are implemented within one instruction cycle. The exceptions to this are branch, call, or table read instructions where two instruction cycles are required. One instruction cycle is equal to 4 system clock cycles, therefore in the case of an 8MHz system oscillator, most instructions would be implemented within 0.5 μ s and branch or call instructions would be implemented within 1 μ s. Although instructions which require one more cycle to implement are generally limited to the JMP, CALL, RET, RETI and table read instructions, it is important to realize that any other instructions which involve manipulation of the Program Counter Low register or PCL will also take one more cycle to implement. As instructions which change the contents of the PCL will imply a direct jump to that new address, one more cycle will be required. Examples of such instructions would be "CLR PCL" or "MOV PCL, A". For the case of skip instructions, it must be noted that if the result of the comparison involves a skip operation then this will also take one more cycle, if no skip is involved then only one cycle is required.

Moving and Transferring Data

The transfer of data within the microcontroller program is one of the most frequently used operations. Making use of three kinds of MOV instructions, data can be transferred from registers to the Accumulator and vice-versa as well as being able to move specific immediate data directly into the Accumulator. One of the most important data transfer applications is to receive data from the input ports and transfer data to the output ports.

Arithmetic Operations

The ability to perform certain arithmetic operations and data manipulation is a necessary feature of most microcontroller applications. Within the Holtek microcontroller instruction set are a range of add and

subtract instruction mnemonics to enable the necessary arithmetic to be carried out. Care must be taken to ensure correct handling of carry and borrow data when results exceed 255 for addition and less than 0 for subtraction. The increment and decrement instructions INC, INCA, DEC and DECA provide a simple means of increasing or decreasing by a value of one of the values in the destination specified.

Logical and Rotate Operations

The standard logical operations such as AND, OR, XOR and CPL all have their own instruction within the Holtek microcontroller instruction set. As with the case of most instructions involving data manipulation, data must pass through the Accumulator which may involve additional programming steps. In all logical data operations, the zero flag may be set if the result of the operation is zero. Another form of logical data manipulation comes from the rotate instructions such as RR, RL, RRC and RLC which provide a simple means of rotating one bit right or left. Different rotate instructions exist depending on program requirements. Rotate instructions are useful for serial port programming applications where data can be rotated from an internal register into the Carry bit from where it can be examined and the necessary serial bit set high or low. Another application where rotate data operations are used is to implement multiplication and division calculations.

Branches and Control Transfer

Program branching takes the form of either jumps to specified locations using the JMP instruction or to a subroutine using the CALL instruction. They differ in the sense that in the case of a subroutine call, the program must return to the instruction immediately when the subroutine has been carried out. This is done by placing a return instruction RET in the subroutine which will cause the program to jump back to the address right after the CALL instruction. In the case of a JMP instruction, the program simply jumps to the desired location. There is no requirement to jump back to the original jumping off point as in the case of the CALL instruction. One special and extremely useful set of branch instructions are the conditional branches. Here a decision is first made regarding the condition of a certain data memory or individual bits. Depending upon the conditions, the program will continue with the next instruction or skip over it and jump to the following instruction. These instructions are the key to decision making and branching within the program perhaps determined by the condition of certain input switches or by the condition of internal data bits.

Bit Operations

The ability to provide single bit operations on Data Memory is an extremely flexible feature of all Holtek microcontrollers. This feature is especially useful for output port bit programming where individual bits or port pins can be directly set high or low using either the "SET [m].i" or "CLR [m].i" instructions respectively. The feature removes the need for programmers to first read the 8-bit output port, manipulate the input data to ensure that other bits are not changed and then output the port with the correct new data. This read-modify-write process is taken care of automatically when these bit operation instructions are used.

Table Read Operations

Data storage is normally implemented by using registers. However, when working with large amounts of fixed data, the volume involved often makes it inconvenient to store the fixed data in the Data Memory. To overcome this problem, Holtek microcontrollers allow an area of Program Memory to be setup as a table where data can be directly stored. A set of easy to use instructions provides the means by which this fixed data can be referenced and retrieved from the Program Memory.

Other Operations

In addition to the above functional instructions, a range of other instructions also exist such as the "HALT" instruction for Power-down operations and instructions to control the operation of the Watchdog Timer for reliable program operations under extreme electric or electromagnetic environments. For their relevant operations, refer to the functional related sections.

Instruction Set Summary

The following table depicts a summary of the instruction set categorised according to function and can be consulted as a basic instruction reference using the following listed conventions.

Table conventions:

x: Bits immediate data

m: Data Memory address

A: Accumulator

i: 0-7 number of bits

addr: Program memory address

Mnemonic	Description	Cycles	Flag Affected
Arithmetic			
ADD A,[m]	Add Data Memory to ACC	1	Z, C, AC, OV
ADDM A,[m]	Add ACC to Data Memory	1 ^{Note}	Z, C, AC, OV
ADD A,x	Add immediate data to ACC	1	Z, C, AC, OV
ADC A,[m]	Add Data Memory to ACC with Carry	1	Z, C, AC, OV
ADCM A,[m]	Add ACC to Data memory with Carry	1 ^{Note}	Z, C, AC, OV
SUB A,x	Subtract immediate data from the ACC	1	Z, C, AC, OV
SUB A,[m]	Subtract Data Memory from ACC	1	Z, C, AC, OV
SUBM A,[m]	Subtract Data Memory from ACC with result in Data Memory	1 ^{Note}	Z, C, AC, OV
SBC A,[m]	Subtract Data Memory from ACC with Carry	1	Z, C, AC, OV
SBCM A,[m]	Subtract Data Memory from ACC with Carry, result in Data Memory	1 ^{Note}	Z, C, AC, OV
DAA [m]	Decimal adjust ACC for Addition with result in Data Memory	1 ^{Note}	C
Logic Operation			
AND A,[m]	Logical AND Data Memory to ACC	1	Z
OR A,[m]	Logical OR Data Memory to ACC	1	Z
XOR A,[m]	Logical XOR Data Memory to ACC	1	Z
ANDM A,[m]	Logical AND ACC to Data Memory	1 ^{Note}	Z
ORM A,[m]	Logical OR ACC to Data Memory	1 ^{Note}	Z
XORM A,[m]	Logical XOR ACC to Data Memory	1 ^{Note}	Z
AND A,x	Logical AND immediate Data to ACC	1	Z
OR A,x	Logical OR immediate Data to ACC	1	Z
XOR A,x	Logical XOR immediate Data to ACC	1	Z
CPL [m]	Complement Data Memory	1 ^{Note}	Z
CPLA [m]	Complement Data Memory with result in ACC	1	Z
Increment & Decrement			
INCA [m]	Increment Data Memory with result in ACC	1	Z
INC [m]	Increment Data Memory	1 ^{Note}	Z
DECA [m]	Decrement Data Memory with result in ACC	1	Z
DEC [m]	Decrement Data Memory	1 ^{Note}	Z

Mnemonic	Description	Cycles	Flag Affected
Rotate			
RRA [m]	Rotate Data Memory right with result in ACC	1	None
RR [m]	Rotate Data Memory right	1 ^{Note}	None
RRCA [m]	Rotate Data Memory right through Carry with result in ACC	1	C
RRC [m]	Rotate Data Memory right through Carry	1 ^{Note}	C
RLA [m]	Rotate Data Memory left with result in ACC	1	None
RL [m]	Rotate Data Memory left	1 ^{Note}	None
RLCA [m]	Rotate Data Memory left through Carry with result in ACC	1	C
RLC [m]	Rotate Data Memory left through Carry	1 ^{Note}	C
Data Move			
MOV A,[m]	Move Data Memory to ACC	1	None
MOV [m],A	Move ACC to Data Memory	1 ^{Note}	None
MOV A,x	Move immediate data to ACC	1	None
Bit Operation			
CLR [m].i	Clear bit of Data Memory	1 ^{Note}	None
SET [m].i	Set bit of Data Memory	1 ^{Note}	None
Branch			
JMP addr	Jump unconditionally	2	None
SZ [m]	Skip if Data Memory is zero	1 ^{Note}	None
SZA [m]	Skip if Data Memory is zero with data movement to ACC	1 ^{note}	None
SZ [m].i	Skip if bit i of Data Memory is zero	1 ^{Note}	None
SNZ [m].i	Skip if bit i of Data Memory is not zero	1 ^{Note}	None
SIZ [m]	Skip if increment Data Memory is zero	1 ^{Note}	None
SDZ [m]	Skip if decrement Data Memory is zero	1 ^{Note}	None
SIZA [m]	Skip if increment Data Memory is zero with result in ACC	1 ^{Note}	None
SDZA [m]	Skip if decrement Data Memory is zero with result in ACC	1 ^{Note}	None
CALL addr	Subroutine call	2	None
RET	Return from subroutine	2	None
RET A,x	Return from subroutine and load immediate data to ACC	2	None
RETI	Return from interrupt	2	None
Table Read			
TABRD [m]	Read table to TBLH and Data Memory	2 ^{note}	None
TABRDL [m]	Read table (last page) to TBLH and Data Memory	2 ^{Note}	None
Miscellaneous			
NOP	No operation	1	None
CLR [m]	Clear Data Memory	1 ^{Note}	None
SET [m]	Set Data Memory	1 ^{Note}	None
CLR WDT	Clear Watchdog Timer	1	TO, PDF
CLR WDT1	Pre-clear Watchdog Timer	1	TO, PDF
CLR WDT2	Pre-clear Watchdog Timer	1	TO, PDF
SWAP [m]	Swap nibbles of Data Memory	1 ^{Note}	None
SWAPA [m]	Swap nibbles of Data Memory with result in ACC	1	None
HALT	Enter power down mode	1	TO, PDF

Note: 1. For skip instructions, if the result of the comparison involves a skip then two cycles are required, if no skip takes place only one cycle is required.
2. Any instruction which changes the contents of the PCL will also require 2 cycles for execution.
3. For the "CLR WDT1" and "CLR WDT2" instructions the TO and PDF flags may be affected by the execution status. The TO and PDF flags are cleared after both "CLR WDT1" and "CLR WDT2" instructions are consecutively executed. Otherwise the TO and PDF flags remain unchanged.

Instruction Definition

ADC A,[m]	Add Data Memory to ACC with Carry
Description	The contents of the specified Data Memory, Accumulator and the carry flag are added. The result is stored in the Accumulator.
Operation	$ACC \leftarrow ACC + [m] + C$
Affected flag(s)	OV, Z, AC, C
ADCM A,[m]	Add ACC to Data Memory with Carry
Description	The contents of the specified Data Memory, Accumulator and the carry flag are added. The result is stored in the specified Data Memory.
Operation	$[m] \leftarrow ACC + [m] + C$
Affected flag(s)	OV, Z, AC, C
ADD A,[m]	Add Data Memory to ACC
Description	The contents of the specified Data Memory and the Accumulator are added. The result is stored in the Accumulator.
Operation	$ACC \leftarrow ACC + [m]$
Affected flag(s)	OV, Z, AC, C
ADD A,x	Add immediate data to ACC
Description	The contents of the Accumulator and the specified immediate data are added. The result is stored in the Accumulator.
Operation	$ACC \leftarrow ACC + x$
Affected flag(s)	OV, Z, AC, C
ADDM A,[m]	Add ACC to Data Memory
Description	The contents of the specified Data Memory and the Accumulator are added. The result is stored in the specified Data Memory.
Operation	$[m] \leftarrow ACC + [m]$
Affected flag(s)	OV, Z, AC, C
AND A,[m]	Logical AND Data Memory to ACC
Description	Data in the Accumulator and the specified Data Memory perform a bitwise logical AND operation. The result is stored in the Accumulator.
Operation	$ACC \leftarrow ACC \text{ "AND" } [m]$
Affected flag(s)	Z
AND A,x	Logical AND immediate data to ACC
Description	Data in the Accumulator and the specified immediate data perform a bitwise logical AND operation. The result is stored in the Accumulator.
Operation	$ACC \leftarrow ACC \text{ "AND" } x$
Affected flag(s)	Z
ANDM A,[m]	Logical AND ACC to Data Memory
Description	Data in the specified Data Memory and the Accumulator perform a bitwise logical AND operation. The result is stored in the Data Memory.
Operation	$[m] \leftarrow ACC \text{ "AND" } [m]$
Affected flag(s)	Z

CALL addr	Subroutine call
Description	Unconditionally calls a subroutine at the specified address. The Program Counter then increments by 1 to obtain the address of the next instruction which is then pushed onto the stack. The specified address is then loaded and the program continues execution from this new address. As this instruction requires an additional operation, it is a two cycle instruction.
Operation	Stack ← Program Counter + 1 Program Counter ← addr
Affected flag(s)	None
CLR [m]	Clear Data Memory
Description	Each bit of the specified Data Memory is cleared to 0.
Operation	[m] ← 00H
Affected flag(s)	None
CLR [m].i	Clear bit of Data Memory
Description	Bit i of the specified Data Memory is cleared to 0.
Operation	[m].i ← 0
Affected flag(s)	None
CLR WDT	Clear Watchdog Timer
Description	The TO, PDF flags and the WDT are all cleared.
Operation	WDT cleared TO ← 0 PDF ← 0
Affected flag(s)	TO, PDF
CLR WDT1	Pre-clear Watchdog Timer
Description	The TO, PDF flags and the WDT are all cleared. Note that this instruction works in conjunction with CLR WDT2 and must be executed alternately with CLR WDT2 to have effect. Repeatedly executing this instruction without alternately executing CLR WDT2 will have no effect.
Operation	WDT cleared TO ← 0 PDF ← 0
Affected flag(s)	TO, PDF
CLR WDT2	Pre-clear Watchdog Timer
Description	The TO, PDF flags and the WDT are all cleared. Note that this instruction works in conjunction with CLR WDT1 and must be executed alternately with CLR WDT1 to have effect. Repeatedly executing this instruction without alternately executing CLR WDT1 will have no effect.
Operation	WDT cleared TO ← 0 PDF ← 0
Affected flag(s)	TO, PDF

CPL [m]	Complement Data Memory
Description	Each bit of the specified Data Memory is logically complemented (1's complement). Bits which previously contained a 1 are changed to 0 and vice versa.
Operation	$[m] \leftarrow \overline{[m]}$
Affected flag(s)	Z
CPLA [m]	Complement Data Memory with result in ACC
Description	Each bit of the specified Data Memory is logically complemented (1's complement). Bits which previously contained a 1 are changed to 0 and vice versa. The complemented result is stored in the Accumulator and the contents of the Data Memory remain unchanged.
Operation	$ACC \leftarrow \overline{[m]}$
Affected flag(s)	Z
DAA [m]	Decimal-Adjust ACC for addition with result in Data Memory
Description	Convert the contents of the Accumulator value to a BCD (Binary Coded Decimal) value resulting from the previous addition of two BCD variables. If the low nibble is greater than 9 or if AC flag is set, then a value of 6 will be added to the low nibble. Otherwise the low nibble remains unchanged. If the high nibble is greater than 9 or if the C flag is set, then a value of 6 will be added to the high nibble. Essentially, the decimal conversion is performed by adding 00H, 06H, 60H or 66H depending on the Accumulator and flag conditions. Only the C flag may be affected by this instruction which indicates that if the original BCD sum is greater than 100, it allows multiple precision decimal addition.
Operation	$[m] \leftarrow ACC + 00H$ or $[m] \leftarrow ACC + 06H$ or $[m] \leftarrow ACC + 60H$ or $[m] \leftarrow ACC + 66H$
Affected flag(s)	C
DEC [m]	Decrement Data Memory
Description	Data in the specified Data Memory is decremented by 1.
Operation	$[m] \leftarrow [m] - 1$
Affected flag(s)	Z
DECA [m]	Decrement Data Memory with result in ACC
Description	Data in the specified Data Memory is decremented by 1. The result is stored in the Accumulator. The contents of the Data Memory remain unchanged.
Operation	$ACC \leftarrow [m] - 1$
Affected flag(s)	Z
HALT	Enter power down mode
Description	This instruction stops the program execution and turns off the system clock. The contents of the Data Memory and registers are retained. The WDT and prescaler are cleared. The power down flag PDF is set and the WDT time-out flag TO is cleared.
Operation	$TO \leftarrow 0$ $PDF \leftarrow 1$
Affected flag(s)	TO, PDF

INC [m]	Increment Data Memory
Description	Data in the specified Data Memory is incremented by 1.
Operation	$[m] \leftarrow [m] + 1$
Affected flag(s)	Z
INCA [m]	Increment Data Memory with result in ACC
Description	Data in the specified Data Memory is incremented by 1. The result is stored in the Accumulator. The contents of the Data Memory remain unchanged.
Operation	$ACC \leftarrow [m] + 1$
Affected flag(s)	Z
JMP addr	Jump unconditionally
Description	The contents of the Program Counter are replaced with the specified address. Program execution then continues from this new address. As this requires the insertion of a dummy instruction while the new address is loaded, it is a two cycle instruction.
Operation	$Program\ Counter \leftarrow addr$
Affected flag(s)	None
MOV A,[m]	Move Data Memory to ACC
Description	The contents of the specified Data Memory are copied to the Accumulator.
Operation	$ACC \leftarrow [m]$
Affected flag(s)	None
MOV A,x	Move immediate data to ACC
Description	The immediate data specified is loaded into the Accumulator.
Operation	$ACC \leftarrow x$
Affected flag(s)	None
MOV [m],A	Move ACC to Data Memory
Description	The contents of the Accumulator are copied to the specified Data Memory.
Operation	$[m] \leftarrow ACC$
Affected flag(s)	None
NOP	No operation
Description	No operation is performed. Execution continues with the next instruction.
Operation	No operation
Affected flag(s)	None
OR A,[m]	Logical OR Data Memory to ACC
Description	Data in the Accumulator and the specified Data Memory perform a bitwise logical OR operation. The result is stored in the Accumulator.
Operation	$ACC \leftarrow ACC \text{ "OR" } [m]$
Affected flag(s)	Z

OR A,x	Logical OR immediate data to ACC
Description	Data in the Accumulator and the specified immediate data perform a bitwise logical OR operation. The result is stored in the Accumulator.
Operation	ACC ← ACC "OR" x
Affected flag(s)	Z
ORM A,[m]	Logical OR ACC to Data Memory
Description	Data in the specified Data Memory and the Accumulator perform a bitwise logical OR operation. The result is stored in the Data Memory.
Operation	[m] ← ACC "OR" [m]
Affected flag(s)	Z
RET	Return from subroutine
Description	The Program Counter is restored from the stack. Program execution continues at the restored address.
Operation	Program Counter ← Stack
Affected flag(s)	None
RET A,x	Return from subroutine and load immediate data to ACC
Description	The Program Counter is restored from the stack and the Accumulator loaded with the specified immediate data. Program execution continues at the restored address.
Operation	Program Counter ← Stack ACC ← x
Affected flag(s)	None
RETI	Return from interrupt
Description	The Program Counter is restored from the stack and the interrupts are re-enabled by setting the EMI bit. EMI is the master interrupt global enable bit. If an interrupt was pending when the RETI instruction is executed, the pending Interrupt routine will be processed before returning to the main program.
Operation	Program Counter ← Stack EMI ← 1
Affected flag(s)	None
RL [m]	Rotate Data Memory left
Description	The contents of the specified Data Memory are rotated left by 1 bit with bit 7 rotated into bit 0.
Operation	[m].(i+1) ← [m].i; (i = 0~6) [m].0 ← [m].7
Affected flag(s)	None
RLA [m]	Rotate Data Memory left with result in ACC
Description	The contents of the specified Data Memory are rotated left by 1 bit with bit 7 rotated into bit 0. The rotated result is stored in the Accumulator and the contents of the Data Memory remain unchanged.
Operation	ACC.(i+1) ← [m].i; (i = 0~6) ACC.0 ← [m].7
Affected flag(s)	None

RLC [m]	Rotate Data Memory left through Carry
Description	The contents of the specified Data Memory and the carry flag are rotated left by 1 bit. Bit 7 replaces the Carry bit and the original carry flag is rotated into bit 0.
Operation	$[m].(i+1) \leftarrow [m].i; (i = 0\sim6)$ $[m].0 \leftarrow C$ $C \leftarrow [m].7$
Affected flag(s)	C
RLCA [m]	Rotate Data Memory left through Carry with result in ACC
Description	Data in the specified Data Memory and the carry flag are rotated left by 1 bit. Bit 7 replaces the Carry bit and the original carry flag is rotated into the bit 0. The rotated result is stored in the Accumulator and the contents of the Data Memory remain unchanged.
Operation	$ACC.(i+1) \leftarrow [m].i; (i = 0\sim6)$ $ACC.0 \leftarrow C$ $C \leftarrow [m].7$
Affected flag(s)	C
RR [m]	Rotate Data Memory right
Description	The contents of the specified Data Memory are rotated right by 1 bit with bit 0 rotated into bit 7.
Operation	$[m].i \leftarrow [m].(i+1); (i = 0\sim6)$ $[m].7 \leftarrow [m].0$
Affected flag(s)	None
RRA [m]	Rotate Data Memory right with result in ACC
Description	Data in the specified Data Memory and the carry flag are rotated right by 1 bit with bit 0 rotated into bit 7. The rotated result is stored in the Accumulator and the contents of the Data Memory remain unchanged.
Operation	$ACC.i \leftarrow [m].(i+1); (i = 0\sim6)$ $ACC.7 \leftarrow [m].0$
Affected flag(s)	None
RRC [m]	Rotate Data Memory right through Carry
Description	The contents of the specified Data Memory and the carry flag are rotated right by 1 bit. Bit 0 replaces the Carry bit and the original carry flag is rotated into bit 7.
Operation	$[m].i \leftarrow [m].(i+1); (i = 0\sim6)$ $[m].7 \leftarrow C$ $C \leftarrow [m].0$
Affected flag(s)	C
RRCA [m]	Rotate Data Memory right through Carry with result in ACC
Description	Data in the specified Data Memory and the carry flag are rotated right by 1 bit. Bit 0 replaces the Carry bit and the original carry flag is rotated into bit 7. The rotated result is stored in the Accumulator and the contents of the Data Memory remain unchanged.
Operation	$ACC.i \leftarrow [m].(i+1); (i = 0\sim6)$ $ACC.7 \leftarrow C$ $C \leftarrow [m].0$
Affected flag(s)	C

SBC A,[m]	Subtract Data Memory from ACC with Carry
Description	The contents of the specified Data Memory and the complement of the carry flag are subtracted from the Accumulator. The result is stored in the Accumulator. Note that if the result of subtraction is negative, the C flag will be cleared to 0, otherwise if the result is positive or zero, the C flag will be set to 1.
Operation	$ACC \leftarrow ACC - [m] - \bar{C}$
Affected flag(s)	OV, Z, AC, C
SBCM A,[m]	Subtract Data Memory from ACC with Carry and result in Data Memory
Description	The contents of the specified Data Memory and the complement of the carry flag are subtracted from the Accumulator. The result is stored in the Data Memory. Note that if the result of subtraction is negative, the C flag will be cleared to 0, otherwise if the result is positive or zero, the C flag will be set to 1.
Operation	$[m] \leftarrow ACC - [m] - \bar{C}$
Affected flag(s)	OV, Z, AC, C
SDZ [m]	Skip if decrement Data Memory is 0
Description	The contents of the specified Data Memory are first decremented by 1. If the result is 0 the following instruction is skipped. As this requires the insertion of a dummy instruction while the next instruction is fetched, it is a two cycle instruction. If the result is not 0 the program proceeds with the following instruction.
Operation	$[m] \leftarrow [m] - 1$ Skip if $[m] = 0$
Affected flag(s)	None
SDZA [m]	Skip if decrement Data Memory is zero with result in ACC
Description	The contents of the specified Data Memory are first decremented by 1. If the result is 0, the following instruction is skipped. The result is stored in the Accumulator but the specified Data Memory contents remain unchanged. As this requires the insertion of a dummy instruction while the next instruction is fetched, it is a two cycle instruction. If the result is not 0, the program proceeds with the following instruction.
Operation	$ACC \leftarrow [m] - 1$ Skip if $ACC = 0$
Affected flag(s)	None
SET [m]	Set Data Memory
Description	Each bit of the specified Data Memory is set to 1.
Operation	$[m] \leftarrow FFH$
Affected flag(s)	None
SET [m].i	Set bit of Data Memory
Description	Bit i of the specified Data Memory is set to 1.
Operation	$[m].i \leftarrow 1$
Affected flag(s)	None

SIZ [m]	Skip if increment Data Memory is 0
Description	The contents of the specified Data Memory are first incremented by 1. If the result is 0, the following instruction is skipped. As this requires the insertion of a dummy instruction while the next instruction is fetched, it is a two cycle instruction. If the result is not 0 the program proceeds with the following instruction.
Operation	$[m] \leftarrow [m] + 1$ Skip if $[m] = 0$
Affected flag(s)	None
SIZA [m]	Skip if increment Data Memory is zero with result in ACC
Description	The contents of the specified Data Memory are first incremented by 1. If the result is 0, the following instruction is skipped. The result is stored in the Accumulator but the specified Data Memory contents remain unchanged. As this requires the insertion of a dummy instruction while the next instruction is fetched, it is a two cycle instruction. If the result is not 0 the program proceeds with the following instruction.
Operation	$ACC \leftarrow [m] + 1$ Skip if $ACC = 0$
Affected flag(s)	None
SNZ [m].i	Skip if bit i of Data Memory is not 0
Description	If bit i of the specified Data Memory is not 0, the following instruction is skipped. As this requires the insertion of a dummy instruction while the next instruction is fetched, it is a two cycle instruction. If the result is 0 the program proceeds with the following instruction.
Operation	Skip if $[m].i \neq 0$
Affected flag(s)	None
SUB A,[m]	Subtract Data Memory from ACC
Description	The specified Data Memory is subtracted from the contents of the Accumulator. The result is stored in the Accumulator. Note that if the result of subtraction is negative, the C flag will be cleared to 0, otherwise if the result is positive or zero, the C flag will be set to 1.
Operation	$ACC \leftarrow ACC - [m]$
Affected flag(s)	OV, Z, AC, C
SUBM A,[m]	Subtract Data Memory from ACC with result in Data Memory
Description	The specified Data Memory is subtracted from the contents of the Accumulator. The result is stored in the Data Memory. Note that if the result of subtraction is negative, the C flag will be cleared to 0, otherwise if the result is positive or zero, the C flag will be set to 1.
Operation	$[m] \leftarrow ACC - [m]$
Affected flag(s)	OV, Z, AC, C
SUB A,x	Subtract immediate data from ACC
Description	The immediate data specified by the code is subtracted from the contents of the Accumulator. The result is stored in the Accumulator. Note that if the result of subtraction is negative, the C flag will be cleared to 0, otherwise if the result is positive or zero, the C flag will be set to 1.
Operation	$ACC \leftarrow ACC - x$
Affected flag(s)	OV, Z, AC, C

SWAP [m]	Swap nibbles of Data Memory
Description	The low-order and high-order nibbles of the specified Data Memory are interchanged.
Operation	[m].3~[m].0 ↔ [m].7 ~ [m].4
Affected flag(s)	None
SWAPA [m]	Swap nibbles of Data Memory with result in ACC
Description	The low-order and high-order nibbles of the specified Data Memory are interchanged. The result is stored in the Accumulator. The contents of the Data Memory remain unchanged.
Operation	ACC.3 ~ ACC.0 ← [m].7 ~ [m].4 ACC.7 ~ ACC.4 ← [m].3 ~ [m].0
Affected flag(s)	None
SZ [m]	Skip if Data Memory is 0
Description	If the contents of the specified Data Memory is 0, the following instruction is skipped. As this requires the insertion of a dummy instruction while the next instruction is fetched, it is a two cycle instruction. If the result is not 0 the program proceeds with the following instruction.
Operation	Skip if [m] = 0
Affected flag(s)	None
SZA [m]	Skip if Data Memory is 0 with data movement to ACC
Description	The contents of the specified Data Memory are copied to the Accumulator. If the value is zero, the following instruction is skipped. As this requires the insertion of a dummy instruction while the next instruction is fetched, it is a two cycle instruction. If the result is not 0 the program proceeds with the following instruction.
Operation	ACC ← [m] Skip if [m] = 0
Affected flag(s)	None
SZ [m].i	Skip if bit i of Data Memory is 0
Description	If bit i of the specified Data Memory is 0, the following instruction is skipped. As this requires the insertion of a dummy instruction while the next instruction is fetched, it is a two cycle instruction. If the result is not 0, the program proceeds with the following instruction.
Operation	Skip if [m].i = 0
Affected flag(s)	None
TABRD [m]	Read table to TBLH and Data Memory
Description	The program code addressed by the table pointer (TBHP and TBLP) is moved to the specified Data Memory and the high byte moved to TBLH.
Operation	[m] ← program code (low byte) TBLH ← program code (high byte)
Affected flag(s)	None
TABRDL [m]	Read table (last page) to TBLH and Data Memory
Description	The low byte of the program code (last page) addressed by the table pointer (TBLP) is moved to the specified Data Memory and the high byte moved to TBLH.
Operation	[m] ← program code (low byte) TBLH ← program code (high byte)
Affected flag(s)	None

XOR A,[m]	Logical XOR Data Memory to ACC
Description	Data in the Accumulator and the specified Data Memory perform a bitwise logical XOR operation. The result is stored in the Accumulator.
Operation	ACC ← ACC "XOR" [m]
Affected flag(s)	Z
XORM A,[m]	Logical XOR ACC to Data Memory
Description	Data in the specified Data Memory and the Accumulator perform a bitwise logical XOR operation. The result is stored in the Data Memory.
Operation	[m] ← ACC "XOR" [m]
Affected flag(s)	Z
XOR A,x	Logical XOR immediate data to ACC
Description	Data in the Accumulator and the specified immediate data perform a bitwise logical XOR operation. The result is stored in the Accumulator.
Operation	ACC ← ACC "XOR" x
Affected flag(s)	Z

Package Information

Note that the package information provided here is for consultation purposes only. As this information may be updated at regular intervals users are reminded to consult the Holtek website (<http://www.holtek.com.tw/english/literature/package.pdf>) for the latest version of the package information.

16-pin DIP (300mil) Outline Dimensions

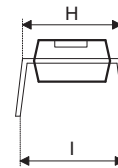
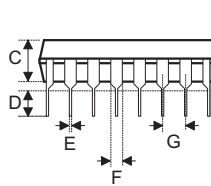
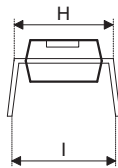
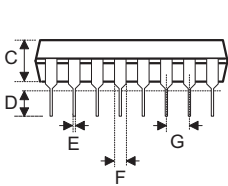
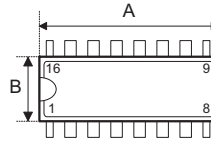
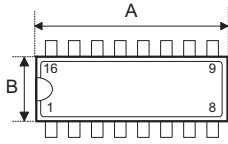

Fig1. Full Lead Packages

Fig2. 1/2 Lead Packages

- MS-001d (see fig1)

Symbol	Dimensions in inch		
	Min.	Nom.	Max.
A	0.780	—	0.880
B	0.240	—	0.280
C	0.115	—	0.195
D	0.115	—	0.150
E	0.014	—	0.022
F	0.045	—	0.070
G	—	0.100	—
H	0.300	—	0.325
I	—	0.430	—

Symbol	Dimensions in mm		
	Min.	Nom.	Max.
A	19.81	—	22.35
B	6.10	—	7.11
C	2.92	—	4.95
D	2.92	—	3.81
E	0.36	—	0.56
F	1.14	—	1.78
G	—	2.54	—
H	7.62	—	8.26
I	—	10.92	—

- MS-001d (see fig2)

Symbol	Dimensions in inch		
	Min.	Nom.	Max.
A	0.735	—	0.775
B	0.240	—	0.280
C	0.115	—	0.195
D	0.115	—	0.150
E	0.014	—	0.022
F	0.045	—	0.070
G	—	0.100	—
H	0.300	—	0.325
I	—	0.430	—

Symbol	Dimensions in mm		
	Min.	Nom.	Max.
A	18.67	—	19.69
B	6.10	—	7.11
C	2.92	—	4.95
D	2.92	—	3.81
E	0.36	—	0.56
F	1.14	—	1.78
G	—	2.54	—
H	7.62	—	8.26
I	—	10.92	—

- MO-095a (see fig2)

Symbol	Dimensions in inch		
	Min.	Nom.	Max.
A	0.745	—	0.785
B	0.275	—	0.295
C	0.120	—	0.150
D	0.110	—	0.150
E	0.014	—	0.022
F	0.045	—	0.060
G	—	0.100	—
H	0.300	—	0.325
I	—	0.430	—

Symbol	Dimensions in mm		
	Min.	Nom.	Max.
A	18.92	—	19.94
B	6.99	—	7.49
C	3.05	—	3.81
D	2.79	—	3.81
E	0.36	—	0.56
F	1.14	—	1.52
G	—	2.54	—
H	7.62	—	8.26
I	—	10.92	—

16-pin NSOP (150mil) Outline Dimensions

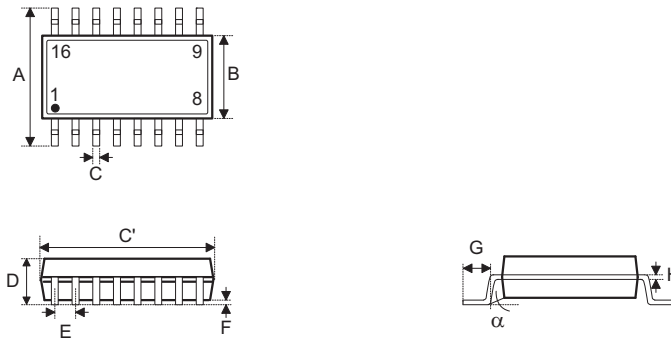

• MS-012

Symbol	Dimensions in inch		
	Min.	Nom.	Max.
A	0.228	—	0.244
B	0.150	—	0.157
C	0.012	—	0.020
C'	0.386	—	0.402
D	—	—	0.069
E	—	0.050	—
F	0.004	—	0.010
G	0.016	—	0.050
H	0.007	—	0.010
α	0°	—	8°

Symbol	Dimensions in mm		
	Min.	Nom.	Max.
A	5.79	—	6.20
B	3.81	—	3.99
C	0.30	—	0.51
C'	9.80	—	10.21
D	—	—	1.75
E	—	1.27	—
F	0.10	—	0.25
G	0.41	—	1.27
H	0.18	—	0.25
α	0°	—	8°

16-pin SSOP (150mil) Outline Dimensions

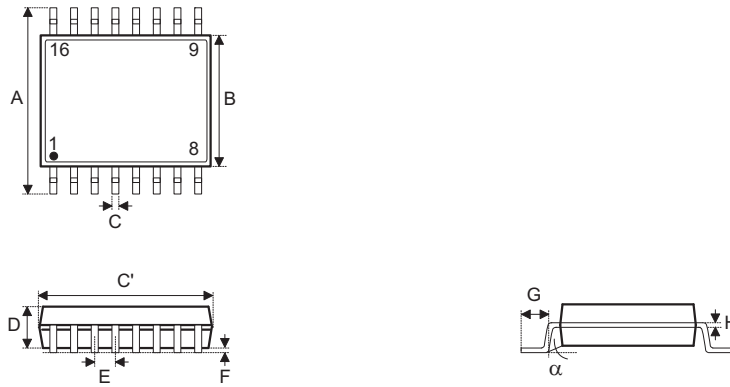

Symbol	Dimensions in inch		
	Min.	Nom.	Max.
A	0.228	—	0.244
B	0.150	—	0.157
C	0.008	—	0.012
C'	0.189	—	0.197
D	0.054	—	0.060
E	—	0.025	—
F	0.004	—	0.010
G	0.022	—	0.028
H	0.007	—	0.010
α	0°	—	8°

Symbol	Dimensions in mm		
	Min.	Nom.	Max.
A	5.79	—	6.20
B	3.81	—	3.99
C	0.20	—	0.30
C'	4.80	—	5.00
D	1.37	—	1.52
E	—	0.64	—
F	0.10	—	0.25
G	0.56	—	0.71
H	0.18	—	0.25
α	0°	—	8°

Product Tape and Reel Specifications

Reel Dimensions

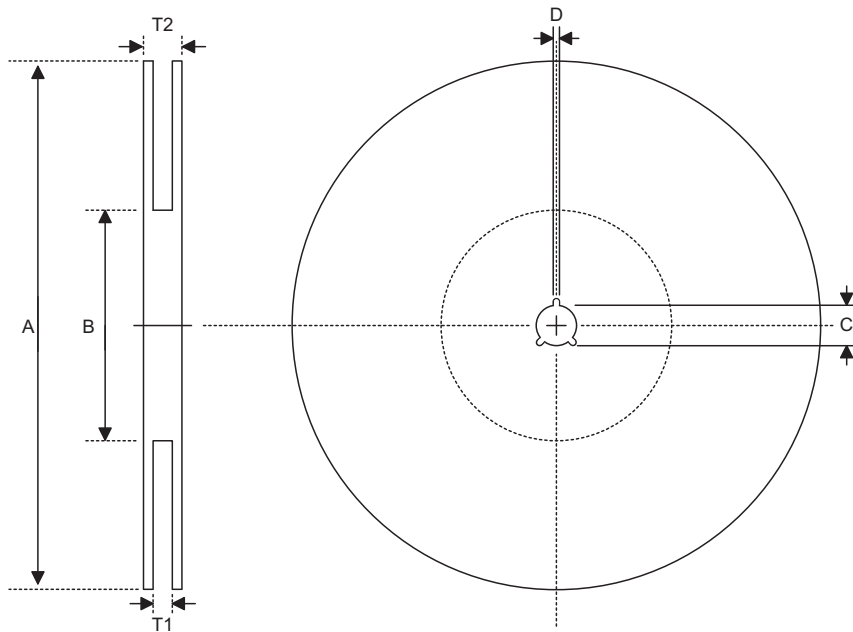

SOP 16N (150mil)

Symbol	Description	Dimensions in mm
A	Reel Outer Diameter	330.0±1.0
B	Reel Inner Diameter	100.0±1.5
C	Spindle Hole Diameter	13.0 ^{+0.5/-0.2}
D	Key Slit Width	2.0±0.5
T1	Space Between Flange	16.8 ^{+0.3/-0.2}
T2	Reel Thickness	22.2±0.2

16-pin SSOP (150mil)

Symbol	Description	Dimensions in mm
A	Reel Outer Diameter	330.0±1.0
B	Reel Inner Diameter	100.0±1.5
C	Spindle Hole Diameter	13.0 ^{+0.5/-0.2}
D	Key Slit Width	2.0±0.5
T1	Space Between Flange	12.8 ^{+0.3/-0.2}
T2	Reel Thickness	18.2±0.2

Carrier Tape Dimensions

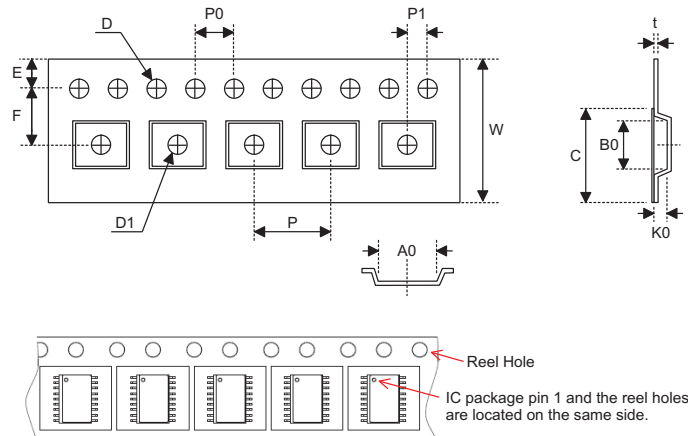

SOP 16N (150mil)

Symbol	Description	Dimensions in mm
W	Carrier Tape Width	16.0±0.3
P	Cavity Pitch	8.0±0.1
E	Perforation Position	1.75±0.1
F	Cavity to Perforation (Width Direction)	7.5±0.1
D	Perforation Diameter	1.55 ^{+0.10/-0.00}
D1	Cavity Hole Diameter	1.50 ^{+0.25/-0.00}
P0	Perforation Pitch	4.0±0.1
P1	Cavity to Perforation (Length Direction)	2.0±0.1
A0	Cavity Length	6.5±0.1
B0	Cavity Width	10.3±0.1
K0	Cavity Depth	2.1±0.1
t	Carrier Tape Thickness	0.30±0.05
C	Cover Tape Width	13.3±0.1

16-pin SSOP (150mil)

Symbol	Description	Dimensions in mm
W	Carrier Tape Width	12.0 ^{+0.3/-0.1}
P	Cavity Pitch	8.0±0.1
E	Perforation Position	1.75±0.10
F	Cavity to Perforation (Width Direction)	5.5±0.1
D	Perforation Diameter	1.55±0.10
D1	Cavity Hole Diameter	1.50 ^{+0.25/-0.00}
P0	Perforation Pitch	4.0±0.1
P1	Cavity to Perforation (Length Direction)	2.0±0.1
A0	Cavity Length	6.4±0.1
B0	Cavity Width	5.2±0.1
K0	Cavity Depth	2.1±0.1
t	Carrier Tape Thickness	0.30±0.05
C	Cover Tape Width	9.3±0.1

Holtek Semiconductor Inc. (Headquarters)

No.3, Creation Rd. II, Science Park, Hsinchu, Taiwan
Tel: 886-3-563-1999
Fax: 886-3-563-1189
<http://www.holtek.com.tw>

Holtek Semiconductor Inc. (Taipei Sales Office)

4F-2, No. 3-2, YuanQu St., Nankang Software Park, Taipei 115, Taiwan
Tel: 886-2-2655-7070
Fax: 886-2-2655-7373
Fax: 886-2-2655-7383 (International sales hotline)

Holtek Semiconductor (China) Inc. (Dongguan Sales Office)

Building No. 10, Xinzhu Court, (No. 1 Headquarters), 4 Cuizhu Road, Songshan Lake, Dongguan, China 523808
Tel: 86-769-2626-1300
Fax: 86-769-2626-1311

Holtek Semiconductor (USA), Inc. (North America Sales Office)

46729 Fremont Blvd., Fremont, CA 94538, USA
Tel: 1-510-252-9880
Fax: 1-510-252-9885
<http://www.holtek.com>

Copyright © 2012 by HOLTEK SEMICONDUCTOR INC.

The information appearing in this Data Sheet is believed to be accurate at the time of publication. However, Holtek assumes no responsibility arising from the use of the specifications described. The applications mentioned herein are used solely for the purpose of illustration and Holtek makes no warranty or representation that such applications will be suitable without further modification, nor recommends the use of its products for application that may present a risk to human life due to malfunction or otherwise. Holtek's products are not authorized for use as critical components in life support devices or systems. Holtek reserves the right to alter its products without prior notification. For the most up-to-date information, please visit our web site at <http://www.holtek.com.tw>.