

Features

MCU Features

- MCU Operating voltage:
f_{sys}= 4MHz: 2.2V~3.6V
f_{sys}= 8MHz: 3.0V~3.6V
- Power Down modes and wake-up functions to reduce power consumption
- Oscillator types
 - External high frequency Crystal
 - External RC
 - Internal RC
 - External low frequency crystal
 - Watchdog Timer Internal RC Oscillator
- Three operational modes: Normal, Slow, Sleep
- Fully integrated internal 4MHz, 8MHz oscillator requires no external components
- OTP Program Memory: 1K×15
- RAM Data Memory: 96×8
- Watchdog Timer function
- All instructions executed in one or two instruction cycles
- Table read instructions
- 63 powerful instructions
- 6-level subroutine nesting
- Bit manipulation instruction
- Low voltage reset function
- 16-pin NSOP package type
- Up to 8 bidirectional I/O lines
- 4 channel 12-bit ADC
- 1 channel 8-bit PWM
- External interrupt input shared with an I/O line
- Two 8-bit programmable Timer/Event Counter with overflow interrupt and prescaler
- Time-Base function
- Programmable Frequency Divider - PFD

RF Transmitter Features

- Complete UHF ASK/OOK transmitter
- Frequency range 300MHz to 450MHz
- Data rates more than 10k bps
- Output Power up to 10dBm
- Low voltage operation - down to 2.2V
- Data tracking function for power saving
- Reference clock output for MCU IRC clock synchronisation

General Description

These devices provide a combination of a fully featured MCU plus an RF transmitter function, giving them great flexibility for use in wide range of wireless I/O control applications such as industrial control, consumer products, subsystem controllers, etc.

Analog features include a multi-channel 12-bit A/D converter. Multiple and extremely flexible Timer/Event Counters provide full timing functions. Protective features such as an internal Watchdog Timer and Low Voltage Reset coupled with excellent noise immunity and ESD protection ensure that reliable operation is maintained in hostile electrical environments. An extensive choice of oscillator functions are provided including a fully integrated system oscillator which requires no external components for its implementation. The ability to operate and switch dynamically between a range of operating modes using different clock sources gives users the ability to optimise microcontroller operation and minimise power consumption. The devices also include flexible I/O programming features Time-Base functions and a range of other features.

The RF transmitter is a high performance and easy to use transmitter operating in the 300MHz to 450MHz frequency band. One only needs to add a crystal reference frequency, and a limited number of external components to create a complete and versatile RF transmitter system. The device is capable of delivering more than +9dBm into a 50Ω load. Such a power level enables a small form factor transmitter to operate near the maximum limit of the transmission regulations. The device can operate with ASK - Amplitude Shift Keying, and OOK - On-Off Keying, UHF receiver types from wide-band super-regenerative radios to narrow-band, high performance super-heterodyne receivers. The data rate is higher than 10kbps, allowing the device to support more complicated control protocols.

For enhanced power saving, the device includes a data tracking function. The data tracking function enables the PLL to be activated as long as high transient data input trigger signals are received. The PLL will also be automatically switched off if there are no data input transients for a time exceeding approximately 300ms. As there is a reference clock input on line PB0, the MCU can use its internal RC clock rather than using an additional crystal for the system clock. These features add up to ensure that the devices can offer excellent capabilities in terms of functionality and power-saving as well as being highly cost effective in a huge range of remote wireless applications

Selection Guide

Part No.	Program Memory	Data Memory	I/O	8-bit Timer	Time Base	RF Transmitter	A/D	PWM	Stack	Package
HT48R01T3	1K×15	96×8	9	2	1	√	—	—	6	16NSOP
HT46R01T3	1K×15	96×8	9	2	1	√	12-bit×4	8-bit×1	6	16NSOP

Block Diagram

The following block diagram illustrates the dual-chip structure of the devices, where an individual MCU and RF Transmitter devices are combined into a single package.

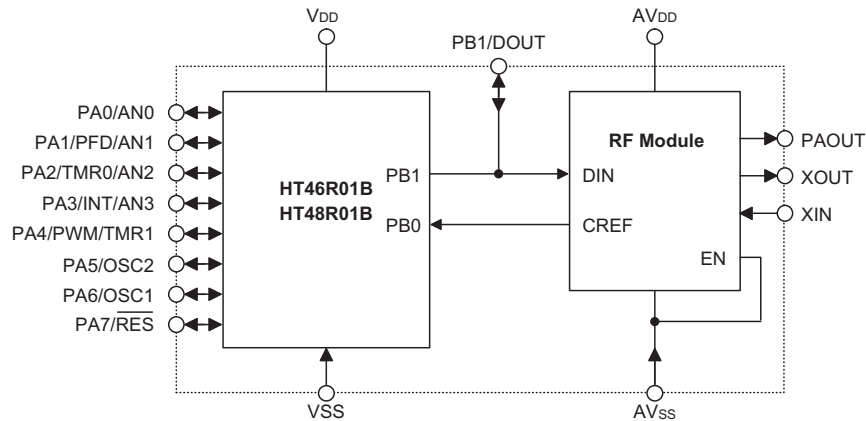

Internal Chip Interconnection Diagram

Note: The PWM and AN0~AN3 shared-pin functions only exist in the HT46R01T3 device.

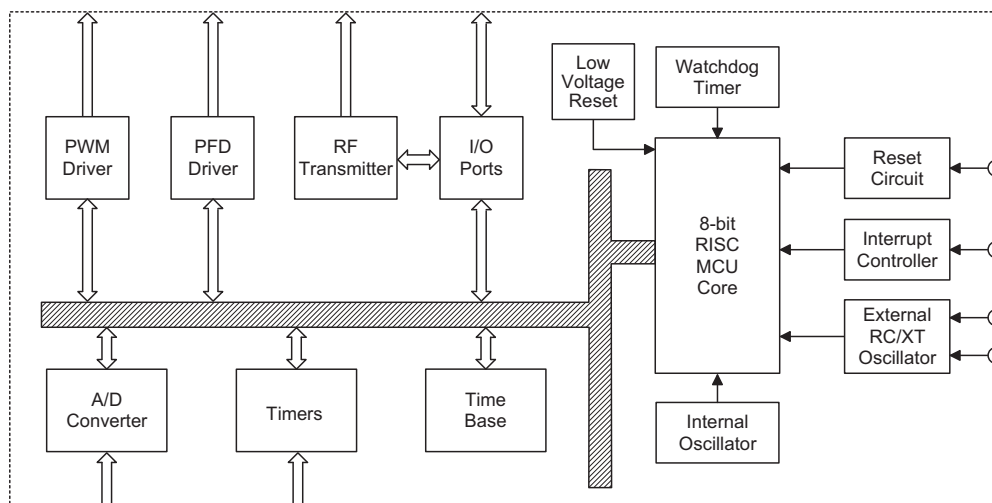

Note: The PWM and A/D Converter functions only exist in the HT46R01T3 device.

Pin Assignment

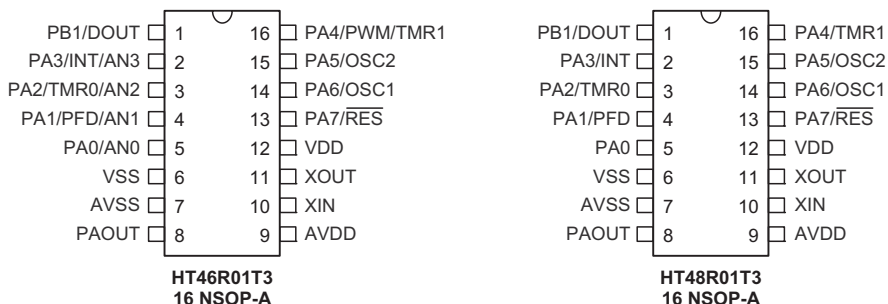

Pin Description

HT46R01T3

Pin Name	Function	OPT	I/T	O/T	Description
PA0/AN0	PA0	PAPU PAWK	ST	CMOS	General purpose I/O. Register enabled pull-up and wake-up.
	AN0	ADCR	AN	—	A/D channel 0
PA1/PFD/AN1	PA1	PAPU PAWK	ST	CMOS	General purpose I/O. Register enabled pull-up and wake-up.
	PFD	CTRL0	—	CMOS	PFD output
	AN1	ADCR	AN	—	A/D channel 1
PA2/TMR0/AN2	PA2	PAPU PAWK	ST	CMOS	General purpose I/O. Register enabled pull-up and wake-up.
	TC0	—	ST	—	External Timer 0 clock input
	AN2	ADCR	AN	—	A/D channel 2
PA3/INT/AN3	PA3	PAPU PAWK	ST	CMOS	General purpose I/O. Register enabled pull-up and wake-up.
	INT	—	ST	—	External interrupt input
	AN3	ADCR	AN	—	A/D channel 3
PA4/TMR1/PWM	PA4	PAPU PAWK	ST	CMOS	General purpose I/O. Register enabled pull-up and wake-up.
	TC1	—	ST	—	External Timer 1 clock input
	PWM	CTRL0	—	CMOS	PWM output
PA5/OSC2	PA5	PAPU PAWK	ST	CMOS	General purpose I/O. Register enabled pull-up and wake-up.
	OSC2	CO	—	OSC	Oscillator pin
PA6/OSC1	PA6	PAPU PAWK	ST	CMOS	General purpose I/O. Register enabled pull-up and wake-up.
	OSC1	CO	OSC	—	Oscillator pin
PA7/ $\overline{\text{RES}}$	PA7	PAWK	ST	NMOS	General purpose I/O. Register enabled wake-up.
	$\overline{\text{RES}}$	CO	ST	—	Reset input

HT46R01T3/HT48R01T3

8-Bit OTP MCU with RF Transmitter



Pin Name	Function	OPT	I/T	O/T	Description
PB1/DOUT	PB1	PBPU	ST	CMOS	General purpose I/O. Register enabled pull-up. Internally connected to DIN pin on RF module. Must be setup as output for interfacing to RF module.
	DOUT	—	—	—	Data output from MCU to RF module Connected internally to PB1
PAOUT	PAOUT	—	—	NSO	RF power amplifier output
XOUT	XOUT	—	—	HXT	RF chip crystal pin
XIN	XIN	—	HXT	—	RF chip crystal pin
VDD	VDD	—	PWR	—	MCU power supply
VSS	VSS	—	PWR	—	MCU ground
AVDD	AVDD	—	PWR	—	RF chip power supply
AVSS	AVSS	—	PWR	—	RF chip ground

Note: I/T: Input type
O/T: Output type
OPT: Optional by configuration option (CO) or register option
PWR: Power
CO: Configuration option
ST: Schmitt Trigger input
CMOS: CMOS output
NSO: Non-standard output

HT48R01T3

Pin Name	Function	OPT	I/T	O/T	Description
PA0	PA0	PAPU PAWK	ST	CMOS	General purpose I/O. Register enabled pull-up and wake-up.
PA1/PFD	PA1	PAPU PAWK	ST	CMOS	General purpose I/O. Register enabled pull-up and wake-up.
	PFD	CTRL0	—	CMOS	PFD output
PA2/TMR0	PA2	PAPU PAWK	ST	CMOS	General purpose I/O. Register enabled pull-up and wake-up.
	TC0	—	ST	—	External Timer 0 clock input
PA3/INT	PA3	PAPU PAWK	ST	CMOS	General purpose I/O. Register enabled pull-up and wake-up.
	INT	—	ST	—	External interrupt input
PA4/TMR1	PA4	PAPU PAWK	ST	CMOS	General purpose I/O. Register enabled pull-up and wake-up.
	TC1	—	ST	—	External Timer 1 clock input
PA5/OSC2	PA5	PAPU PAWK	ST	CMOS	General purpose I/O. Register enabled pull-up and wake-up.
	OSC2	CO	—	OSC	Oscillator pin
PA6/OSC1	PA6	PAPU PAWK	ST	CMOS	General purpose I/O. Register enabled pull-up and wake-up.
	OSC1	CO	OSC	—	Oscillator pin

Pin Name	Function	OPT	I/T	O/T	Description
PA7/ $\overline{\text{RES}}$	PA7	PAWK	ST	NMOS	General purpose I/O. Register enabled wake-up.
	$\overline{\text{RES}}$	CO	ST	—	Reset input
PB1/DOUT	PB1	PBPU	ST	CMOS	General purpose I/O. Register enabled pull-up. Internally connected to DIN pin on RF module. Must be setup as output for interfacing to RF module.
	DOUT	—	—	—	Data output from MCU to RF module Connected internally to PB1
PAOUT	PAOUT	—	—	NSO	RF power amplifier output
XOUT	XOUT	—	—	HXT	RF chip crystal pin
XIN	XIN	—	HXT	—	RF chip crystal pin
VDD	VDD	—	PWR	—	MCU power supply
VSS	VSS	—	PWR	—	MCU ground
AVDD	AVDD	—	PWR	—	RF chip power supply
AVSS	AVSS	—	PWR	—	RF chip ground

Note: I/T: Input type
O/T: Output type
OPT: Optional by configuration option (CO) or register option
PWR: Power
CO: Configuration option
ST: Schmitt Trigger input
CMOS: CMOS output
NSO: Non-standard output

Internally Connected Pins

In addition to the internal connection between MCU pin, PB1, and RF Transmitter pin, DIN, the MCU pin, PB0, and RF Transmitter pin, CREF, are also internally connected. However it should be noted that PB0/CREF is not connected to any external pins on the device package.

Pin Name	Function	OPT	I/T	O/T	Description
PB0/CREF	PB0	PBPU	ST	CMOS	General Purpose I/O. Register enabled pull-high resistor. Internally connected to CREF pin on RF module. Must be setup as an input for interfacing to RF module. Not available on package.
	CREF	—	—	—	RF Transmitter generated pulses for synchronisation. Connected internally to PB0. Not available on package.

HT46R01T3/HT48R01T3

8-Bit OTP MCU with RF Transmitter



D.C. Characteristics

Ta=25°C

Symbol	Parameter	Test Conditions		Min.	Typ.	Max.	Unit
		V _{DD}	Conditions				
V _{DD}	Operating Voltage	—	f _{sys} =4MHz	2.2	—	3.6	V
			f _{sys} =8MHz	3.3	—	3.6	V
AV _{DD}	RF Transmitter Power Supply	—	—	2.0	—	3.6	V
I _{DD1}	Operating current (Crystal OSC, RC OSC)	3V	No load, f _{sys} =4MHz, ADC disable	—	1	2	mA
I _{DD2}	Operating Current (internal RC+RTC OSC, Normal Mode)	3V	No load, f _{sys} =4MHz, ADC disable	—	1	2	mA
I _{STB1}	Standby Current (WDT OSC on, RTC off)	3V	No load, system HALT	—	—	5	μA
I _{STB2}	Standby Current (WDT OSC off, RTC off)	3V	No load, system HALT	—	—	1	μA
I _{STB3}	Standby Current (WDT OSC off, RTC on)	3V	No load, system HALT, RTC osc slowly start-up	—	—	5	μA
V _{IL1}	Input Low Voltage for PA, PB, TMR0, TMR1, INT	—	—	0	—	0.3V _{DD}	V
V _{IH1}	Input High Voltage for PA, PB, TMR0, TMR1, INT	—	—	0.7V _{DD}	—	V _{DD}	V
V _{IL2}	Input Low Voltage ($\overline{\text{RES}}$)	—	—	0	—	0.4V _{DD}	V
V _{IH2}	Input High Voltage ($\overline{\text{RES}}$)	—	—	0.9V _{DD}	—	V _{DD}	V
V _{LVR1}	Low Voltage Reset 1	—	Configuration option=2.1V	1.98	2.10	2.22	V
V _{LVR2}	Low Voltage Reset 2	—	Configuration option=3.15V	2.98	3.15	3.32	V
I _{OL}	I/O Port Sink Current for PA, PB	3V	V _{OL} =0.1V _{DD}	4	8	—	mA
I _{OH}	I/O Port Source Current for PA, PB	3V	V _{OH} =0.9V _{DD}	-2	-4	—	mA
R _{PH}	Pull-high Resistance for I/O	3V	—	20	60	100	kΩ

A.C. Characteristics

Ta=25°C

Symbol	Parameter	Test Conditions		Min.	Typ.	Max.	Unit
		V _{DD}	Conditions				
f _{HIRC}	System Clock (HIRC)	3V	Ta= -40°C~85°C	-10%	4/8	+10%	MHz
f _{TIMER}	Timer Input Frequency (TCn)	—	2.2V~3.6V	0	—	4000	kHz
			3.3V~3.6V	0	—	8000	kHz
t _{WDTOSC}	Watchdog Oscillator Period	3V	—	45	90	180	μs
t _{RES}	External Reset Low Pulse Width	—	—	1	—	—	μs
t _{SST}	System Start-up Time Period	—	Wake-Up from HALT	—	1024	—	t _{sys}
t _{INT}	Interrupt Pulse Width	—	—	1	—	—	μs
t _{LVR}	Low Voltage Width to Reset	—	—	0.25	1.00	2.00	ms

Note: 1. t_{sys}=1/f_{sys}
2. *For f_{ERC}, as the resistor tolerance will influence the frequency a precision resistor is recommended.

A/D Converter Electrical Characteristics

Ta=25°C

Symbol	Parameter	Test Conditions		Min.	Typ.	Max.	Unit
		V _{DD}	Conditions				
V _{ADC}	A/D Operating Voltage	—	V _{REF} =V _{ADC}	2.7	—	3.6	V
V _{ADI}	A/D Converter Input Voltage	—	—	0	—	V _{ADC} / V _{REF}	V
V _{REF}	A/D Converter Input reference Voltage Range	—	V _{ADC} =3V	TBD (TBC)	—	V _{ADC} +0.1	V
DNL	A/D Converter Differential Non-Linearity	2.7V	V _{REF} =V _{ADC} =V _{DD} , t _{AD} =0.5μs	-2	—	2	LSB
		3V					
INL	A/D Converter Integral Non-Linearity	2.7V	V _{REF} =V _{ADC} =V _{DD} , t _{AD} =0.5μs (calculated on best-fit line)	-4	—	4	LSB
		3V					
I _{ADC}	Additional Power Consumption if A/D Converter is Used	3V	No load, t _{AD} =0.5μs	—	0.5	—	mA
t _{AD}	A/D Converter Clock Period	2.7V~3.6V	—	0.5	—	10	μs
t _{ADC}	A/D Converter Sampling Time (see note)	2.7V~3.6V	12-bit ADC	—	16	—	t _{AD}
t _{ON2ST}	A/D Converter on to ADC Start	2.7V~3.6V	—	2	—	—	μs

Note: ADC conversion time (t_{AD})= n (bits ADC) + 4 (sampling time), the conversion for each bit needs one ADC clock(t_{AD}).

RF Transmitter Electrical Characteristics

Specifications apply for $V_{DD}=3.0V$, $T_a = 25^{\circ}C$, Freq X'tal OSC=13.560MHz, DATA is transmitting. Bold values indicate $-20^{\circ}C$ to $70^{\circ}C$ unless otherwise noted. 1kbps data rate 50% duty cycle. RL 50Ω load (matched)

Symbol	Parameter	Test Conditions		Min.	Typ.	Max.	Unit
		V_{DD}	Conditions				
I_I	Data High Current	3V	@315MHz, POUT=+10dBm	—	12.5	—	mA
			@433.92MHz	—	12.5	—	mA
I_O	Data Low Current	3V	@315MHz	—	3.0	—	mA
			@433.92 MHz	—	3.0	—	mA
I_{STB}	EN Low & DIN Low Current	3V	@315MHz	—	1.0	—	μA
			@433.92 MHz	—	1.0	—	μA
RF and Crystal							
	Output power level	3.3V	@315MHz *	—	9.5	—	dBm
			@433.92MHz *	—	9.5	—	dBm
	Harmonics output for 315 MHz	3V	@630MHz, 2nd harm	—	-48	—	dBc
			@945MHz, 3rd harm	—	-60	—	dBc
	Harmonics Output for 433.92MHz	3V	@867.84MHz, 2nd harm	—	-45	—	dBc
			@1301.76MHz, 3rd harm	—	-55	—	dBc
	Extinction Ratio for ASK 10Kbps	3V	—	—	70	—	dBc
	Data Rate	3V	—	10	—	—	kbps
	Occupied Bandwidth	3V	@315MHz	—	<900	—	kHz
			@433.92MHz	—	<1000	—	kHz
	315MHz Single Side Band Phase Noise	3V	100kHz from Carrier	—	-78	—	dBc/Hz
			1000kHz from Carrier	—	-77	—	dBc/Hz
	433.92MHz Single Side Band Phase Noise	3V	100kHz from Carrier	—	-78	—	dBc/Hz
			1000kHz from Carrier	—	-76	—	dBc/Hz
	XTLIN, XTLOUT	3V	Pin capacitance	—	2	—	pF
	Output Blanking	3V	Standby transition from low to high **	—	500	—	μs
	ASK to RF Out Response Time	3V	Delta between ASK input transition from Low To High to RF output transition from low to high	—	1	—	μs
	CREF Clock Output Frequency	3V	@315MHz	—	150	—	Hz
			@433.92MHz	—	207	—	Hz

Note: * Depend on PC board layout

** Generally limited by crystal

Power-on Reset Characteristics

Ta=25°C

Symbol	Parameter	Test Conditions		Min.	Typ.	Max.	Unit
		V _{DD}	Conditions				
V _{POR}	VDD Start Voltage to Ensure Power-on Reset	—	—	—	—	100	mV
RR _{VDD}	VDD raising rate to Ensure Power-on Reset	—	—	0.035	—	—	V/ms
V _{POR MAX}	Maximum V _{DD} Start Voltage to Ensure Power-on Reset	—	Ta=25°C, without 0.1μF between V _{DD} and V _{SS}	0.9	—	1.5	V
			Ta=-40°C~85°C, without 0.1μF between V _{DD} and V _{SS}	0.6	—	1.8	V
t _{POR}	Power-on Reset Low Pulse Width	—	without 0.1μF between V _{DD} and V _{SS}	2	—	—	μs
			without 0.1μF between V _{DD} and V _{SS}	TBD	—	—	μs

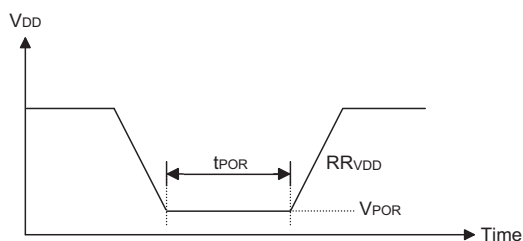

Functional Description

As these device packages contain different chips, for a detailed functional description, users must refer to the relevant datasheets for the related MCU. The following table shows which individual devices are inside each package.

Device	MCU
HT48R01T3	HT48R01B
HT46R01T3	HT46R01B

Multi-chip Internal Devices

The MCU controls the RF transmitter via a two line interface using two of its I/O pins, PB0 and PB1. Pin PB1, which should be setup as an output by the MCU, is used to generate the encoding data. Pin PB0, which should be setup as an input by the MCU, is used for synchronising purposes. There are some special considerations which need to be taken into account when using these devices. These points will be mentioned in the hardware and software consideration sections.

Hardware Considerations

As these devices are composed of an individual MCU and RF Transmitter, using them together requires the user to take care of some special points.

Absolute Maximum Ratings

The Absolute Maximum Ratings must be checked for discrepancies and the necessary care taken in device handling and usage.

Power Supply

Examination of the block diagram will reveal that the Power Supply and Ground pins of the RF Transmitter and MCU are independent and must be connected together if they are to share the same power supply. If the same power supply is to be used for both chips then care must be taken as both have different power supply requirements.

When calculating the total current consumption of the device, the internal DC specification currents for the MCU and RF parts must be added together.

The RF data to be transmitted is derived from the PB1 line. When the PB1 line is high the device will transmit allowing users to program their encoded data on this line. If the RF transmitter is in its standby mode then there will be a delay of about 500 μ s before transmission begins. When the device is transmitting, a synchronising signal will be generated on the CREF/PB0 pin which allows the MCU to use it to calibrate its internal RC oscillator. To avoid the RF circuits entering an unknown state, pin PB1 should be setup as an output as soon as possible after power-on.

To minimise power consumption, only when PB1 is high, can the RF signal be transmitted and the reference clock on PB0 be generated. If no data transitions are generated on PB1 for 300~500ms, the transmitter will enter a standby state and the RF circuits will be switched off along with the internal PLL to save power. The signal generated on the CREF/PB0 line will also remain at a low level. The internal PLL function is used to generate the RF frequency with a multiplier of 32 times the crystal frequency. The relationship is: RF frequency = 32 \times Crystal frequency. Therefore a 9.84375MHz crystal will generate an RF frequency of 315MHz and a 13.56MHz crystal will generate an RF frequency of 433.92MHz. All PLL circuits are contained within the device and the only external component required is a suitable crystal.

Power Down and Wake up

It is important to note that if the MCU is powered down or placed into a low power mode to conserve power, that the RF Transmitter may continue running and will consume a certain amount of power. Before powering down the MCU it is important to carefully manage the PB1 pin to ensure the RF-Transmitter enters its power down state.

Programming Considerations

As MCU lines PB0 and PB1 are used to control the RF transmitter function, care must be taken to manage these lines correctly in the application program. As line PB1 is used to send data to the RF circuitry this line must be setup as an output. To avoid erroneous operation of the RF circuits this line should be setup as an output immediately after power-on. The PB0 pin on the MCU is used to receive synchronising pulses from the RF circuits and should therefore be setup as an input.

As the MCU will be powered down independently of the RF Transmitter Peripheral Module, care must be taken to ensure that the MCU first clears its PB1 line to zero before powering down. This will allow the RF Transmitter Peripheral Module to enter its standby state and thus keep power consumption to a minimum.

Application Circuits

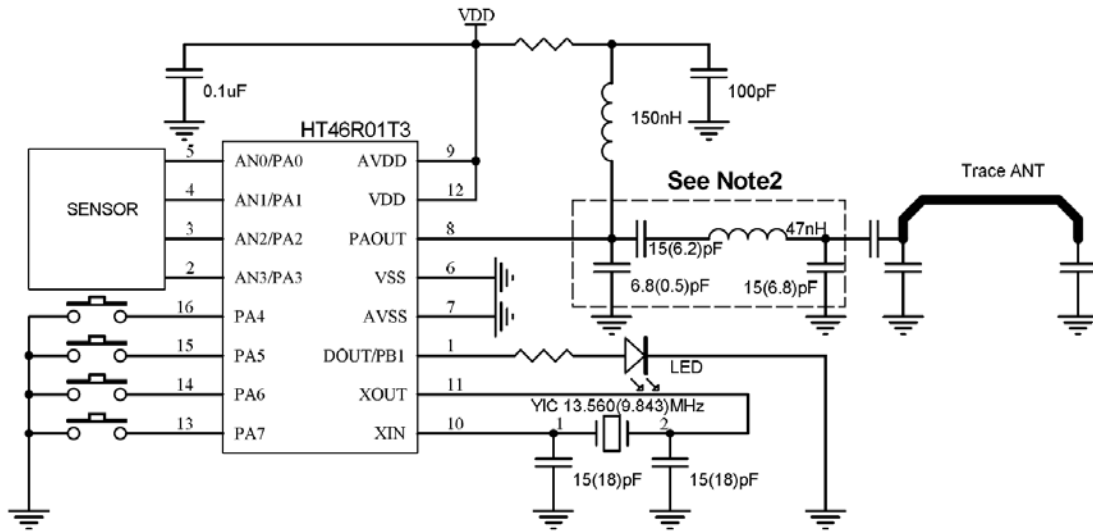

- Note:
1. 9.84375MHz crystal used for RF frequency of 315MHz
13.56MHz crystal used for RF frequency of 433.92MHz
 2. The extra LC filter on the PAOUT pin can reduce second harmonics
 3. The L and C values shown in brackets are for 433.92MHz

Package Information

16-pin NSOP (150mil) Outline Dimensions

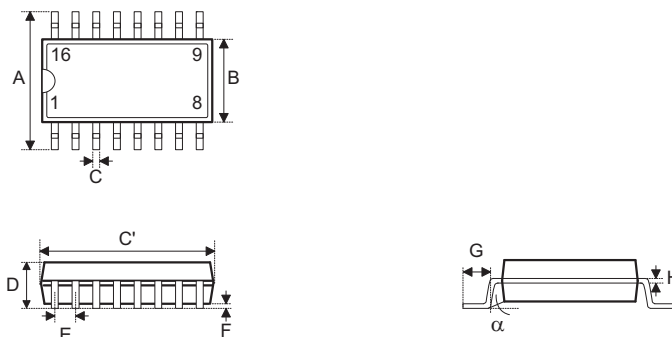

MS-012

Symbol	Dimensions in inch		
	Min.	Nom.	Max.
A	0.228	—	0.244
B	0.150	—	0.157
C	0.012	—	0.020
C'	0.386	—	0.402
D	—	—	0.069
E	—	0.050	—
F	0.004	—	0.010
G	0.016	—	0.050
H	0.007	—	0.010
α	0°	—	8°

Symbol	Dimensions in mm		
	Min.	Nom.	Max.
A	5.79	—	6.20
B	3.81	—	3.99
C	0.30	—	0.51
C'	9.80	—	10.21
D	—	—	1.75
E	—	1.27	—
F	0.10	—	0.25
G	0.41	—	1.27
H	0.18	—	0.25
α	0°	—	8°

Reel Dimensions

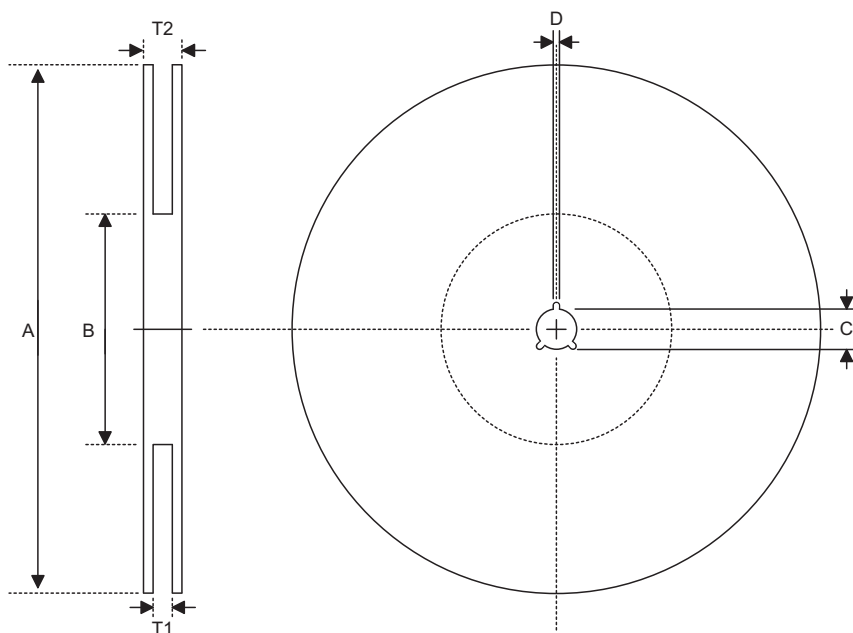

SOP 16N (150mil)

Symbol	Description	Dimensions in mm
A	Reel Outer Diameter	330.0±1.0
B	Reel Inner Diameter	100.0±1.5
C	Spindle Hole Diameter	13.0 ^{+0.5/-0.2}
D	Key Slit Width	2.0±0.5
T1	Space Between Flange	16.8 ^{+0.3/-0.2}
T2	Reel Thickness	22.2±0.2

Carrier Tape Dimensions

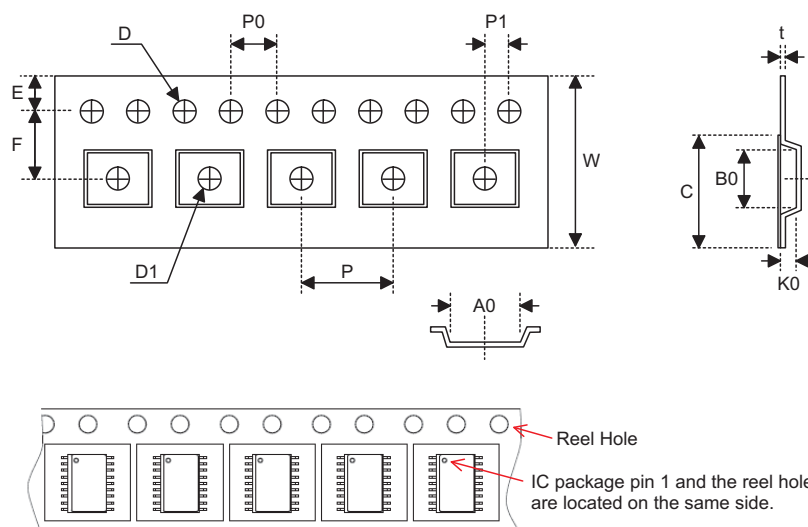

SOP 16N (150mil)

Symbol	Description	Dimensions in mm
W	Carrier Tape Width	16.0±0.3
P	Cavity Pitch	8.0±0.1
E	Perforation Position	1.75±0.1
F	Cavity to Perforation (Width Direction)	7.5±0.1
D	Perforation Diameter	1.55 ^{+0.10/-0.00}
D1	Cavity Hole Diameter	1.50 ^{+0.25/-0.00}
P0	Perforation Pitch	4.0±0.1
P1	Cavity to Perforation (Length Direction)	2.0±0.1
A0	Cavity Length	6.5±0.1
B0	Cavity Width	10.3±0.1
K0	Cavity Depth	2.1±0.1
t	Carrier Tape Thickness	0.30±0.05
C	Cover Tape Width	13.3±0.1

Copyright © 2010 by HOLTEK SEMICONDUCTOR INC.

The information appearing in this Data Sheet is believed to be accurate at the time of publication. However, Holtek assumes no responsibility arising from the use of the specifications described. The applications mentioned herein are used solely for the purpose of illustration and Holtek makes no warranty or representation that such applications will be suitable without further modification, nor recommends the use of its products for application that may present a risk to human life due to malfunction or otherwise. Holtek's products are not authorized for use as critical components in life support devices or systems. Holtek reserves the right to alter its products without prior notification. For the most up-to-date information, please visit our web site at <http://www.holtek.com.tw>.