

Technical Document

- [Tools Information](#)
- [FAQs](#)
- [Application Note](#)
 - [HA0003E Communicating between the HT48 & HT46 Series MCUs and the HT93LC46 EEPROM](#)
 - [HA0049E Read and Write Control of the HT1380](#)
 - [HA0075E MCU Reset and Oscillator Circuits Application Note](#)

Features

- Operating voltage:
 - $f_{SYS}=32768\text{Hz}$: 2.2V~5.5V
 - $f_{SYS}=4\text{MHz}$: 2.2V~5.5V
 - $f_{SYS}=8\text{MHz}$: 3.3V~5.5V
- 8 bidirectional I/O lines
- Max. 16×16 LED driver output
- 8 LED shared I/O lines
- 24 LED shared output
- External dual edge triggered interrupt input shared with I/O line
- Single 8-bit programmable Timer/Event Counters with overflow interrupt
- RC/XTAL and 32768Hz crystal oscillators
- Dual clock system offers three operating modes
 - Normal mode: Both RC/XTAL and 32768Hz clock active
 - Slow mode: 32768Hz clock only
 - Power-down mode can have periodical wake-up using the watchdog timer overflow
- Watchdog Timer
- 2048×14 program memory
- 88×8 data memory
- Power down and wake-up functions to reduce power consumption
- Up to 0.5 μs instruction cycle with 8MHz system clock at $V_{DD}=5\text{V}$
- 6-level subroutine nesting
- 6 channel 12-bit resolution A/D converter
- 2 channel 8-bit PWM output shared with I/O lines
- 1/2 bias 4 common LCD
- Bit manipulation instruction
- Table read instructions
- 63 powerful instructions
- All instructions executed in one or two machine cycles
- Low voltage reset function
- 44/52-pin QFP package

General Description

The HT46R92 is an 8-bit high performance RISC architecture microcontroller, the device is designed especially for applications that interface directly to analog signals, such as those from sensors. The devices include an integrated multi-channel Analog to Digital Converter in addition to two Pulse Width Modulation outputs. An internal high current LED driver circuit also provides for easy interfacing to applications which contain LED displays.

The usual Holtek MCU features such as power down and wake-up functions, oscillator options, etc. combine to ensure user applications require a minimum of external components.

The benefits of integrated A/D and PWM functions, in addition to low power consumption, high performance, I/O flexibility and low-cost, provides the device with the versatility to suit a wide range of application possibilities such as sensor signal processing, motor driving, industrial control, consumer products, subsystem controllers, etc.

As is the case with all Holtek microcontroller devices, the HT46R92 is fully supported by a full suite of professional hardware and software tools, containing comprehensive features to ensure user applications are designed and debugged in as short a time as possible.

Block Diagram

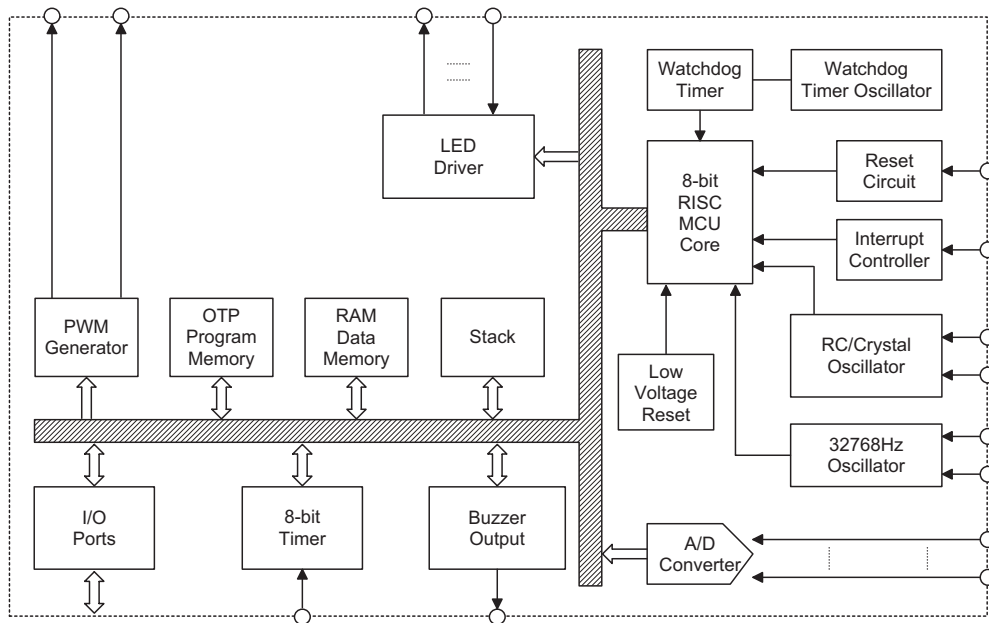

Pin Assignment

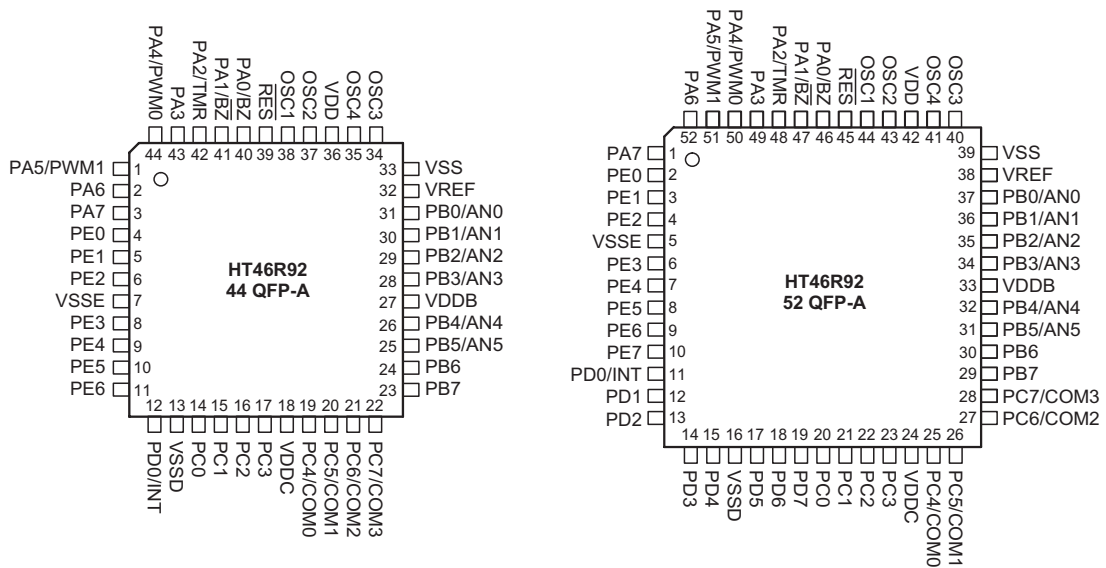

Pin Description

Pin Name	I/O	Configuration Option	Description
PA0/BZ PA1/BZ PA2/TMR PA3 PA4/PWM0 PA5/PWM1 PA6, PA7	I/O	Pull-high, Wake-up, BZ/BZ, PWM0~PWM1	Bidirectional 8-bit input/output port. Each individual pin on this port can be configured as a wake-up input by a configuration option. Software instructions determine if the pin is a CMOS output or Schmitt Trigger input. A configuration option determines if all pins on the port have pull-high resistors. Pins PA0, PA1, PA2, PA4 and PA5 are pin-shared with BZ, $\overline{\text{BZ}}$, TMR, PWM0 and PWM1, respectively.
PB0/AN0 PB1/AN1 PB2/AN2 PB3/AN3 PB4/AN4 PB5/AN5 PB6, PB7	I/O	—	Bidirectional 8-bit input/output port. Software instructions determine if the pin is a CMOS output or Schmitt Trigger input. PB is pin-shared with the A/D input pins. The A/D inputs are selected via software instructions. Once selected as an A/D input, the I/O function is disabled automatically.
PC0~PC3 PC4/COM0 PC5/COM1 PC6/COM2 PC7/COM3	O	—	8-bit CMOS output port. PC4~PC7 can be used as COM0~COM3.
PD0/INT PD1~PD7	I/O O	—	8-bit CMOS output port. PD0 is pin-shared with the external interrupt input pin.
PE0~PE7	O	—	8-bit CMOS output port.
OSC1 OSC2	I O	Crystal or RC	OSC1, OSC2 are connected to an external RC network or external crystal, determined by configuration option, for the internal system clock. If the RC system clock option is selected, pin OSC2 can be used to measure the system clock at 1/4 frequency.
OSC3 OSC4	I O	—	OSC3 and OSC4 are connected to an external 32768Hz crystal oscillator to implement a system clock and real time clock.
RES	I	—	Schmitt Trigger reset input. Active low.
VDD	—	—	Positive power supply
VSS	—	—	Negative power supply, ground
VREF			A/D Reference voltage input pin.
VDDB VDDC	—	—	PB & PC port positive power supply
VSSD, VSSE	—	—	PD & PE port negative power supply, ground

- Note:
1. Each pin on PA can be programmed through a configuration option to have a wake-up function.
 2. As the table applies to the larger package size not all pins may exist on the smaller packages.

Absolute Maximum Ratings

Supply Voltage	$V_{SS}-0.3V$ to $V_{SS}+6.0V$	Storage Temperature	$-50^{\circ}C$ to $125^{\circ}C$
Input Voltage	$V_{SS}-0.3V$ to $V_{DD}+0.3V$	Operating Temperature	$-40^{\circ}C$ to $85^{\circ}C$
I_{OL} Total	150mA	I_{OH} Total	$-100mA$
Total Power Dissipation	500mW		

Note: These are stress ratings only. Stresses exceeding the range specified under "Absolute Maximum Ratings" may cause substantial damage to the device. Functional operation of this device at other conditions beyond those listed in the specification is not implied and prolonged exposure to extreme conditions may affect device reliability.

D.C. Characteristics
 $T_a=25^{\circ}C$

Symbol	Parameter	Test Conditions		Min.	Typ.	Max.	Unit
		V_{DD}	Conditions				
V_{DD}	Operating Voltage	—	$f_{SYS}=32768Hz$	2.2	—	5.5	V
		—	$f_{SYS}=4MHz$	2.2	—	5.5	
		—	$f_{SYS}=8MHz$	3.3	—	5.5	V
V_{AVDD}	Analog Operating Voltage	—	$V_{AVDD}=V_{DD}$	2.7	—	5.5	V
I_{DD1}	Operating Current (Crystal OSC, RC OSC)	3V	No load, $f_{SYS}=4MHz$, ADC disable	—	1	2	mA
		5V		—	2.5	5	mA
I_{DD2}	Operating Current (RC OSC, RTC OSC)	5V	No load, $f_{SYS}=8MHz$, ADC disable	—	4	8	mA
I_{DD3}	Operating Current (RTC* OSC, RC Off)	3V	No load, $f_{SYS}=32768Hz$, ADC disable	—	20	40	μA
		5V		—	50	100	μA
I_{STB1}	Standby Current (WDT & RTC* Enabled)	3V	No load, system HALT	—	3	5	μA
		5V		—	6	10	μA
I_{STB2}	Standby Current (WDT Disabled, RTC* Enabled)	3V	No load, system HALT	—	1	2	μA
		5V		—	2	4	μA
I_{STB3}	Standby Current (WDT Enabled & RTC* Disabled)	3V	No load, system HALT	—	2	4	μA
		5V		—	4	8	μA
I_{STB4}	Standby Current (WDT & RTC* Disabled)	3V	No load, system HALT	—	—	1	μA
		5V		—	—	2	μA
I_{STB5}	Standby Current with 200K (see note 2) Resistor On for 1/2 V_{DD} Bias (WDT & RTC Disabled)	3V	No load, system HALT	—	30	50	μA
V_{IL1}	Input Low Voltage for I/O Ports	—	—	0	—	$0.3V_{DD}$	V
V_{IH1}	Input High Voltage for I/O Ports	—	—	$0.7V_{DD}$	—	V_{DD}	V
V_{IL2}	Input Low Voltage (\overline{RES})	—	—	0	—	$0.4V_{DD}$	V
V_{IH2}	Input High Voltage (\overline{RES})	—	—	$0.9V_{DD}$	—	V_{DD}	V
V_{LVR}	Low Voltage Reset	—	—	1.98	2.1	2.22	V
				2.98	3.15	3.32	V
				3.98	4.2	4.42	V
I_{OL1}	I/O Port Sink Current for PA	3V	$V_{OL}=0.1V_{DD}$	4	8	—	mA
		5V	$V_{OL}=0.1V_{DD}$	10	20	—	mA

Symbol	Parameter	Test Conditions		Min.	Typ.	Max.	Unit
		V _{DD}	Conditions				
I _{OL2}	I/O Port Sink Current for PB, PC	3V	V _{OL} =0.1V _{DD}	0.6	1.3	—	mA
		5V	V _{OL} =0.1V _{DD}	1.5	3.0	—	mA
I _{OL3}	I/O Port Sink Current for PD, PE	3V	V _{OL} =0.1V _{DD}	12	24	—	mA
		5V	V _{OL} =0.1V _{DD}	30	60	—	mA
I _{OH1}	I/O Port Source Current for PA	3V	V _{OH} =0.9V _{DD}	-2	-4	—	mA
		5V	V _{OH} =0.9V _{DD}	-5	-10	—	mA
I _{OH2}	I/O Port Source Current for PB, PC	3V	V _{OH} =0.9V _{DD}	-4	-8	—	mA
		5V	V _{OH} =0.9V _{DD}	-10	-20	—	mA
I _{OH3}	I/O Port Source Current for PD, PE	3V	V _{OH} =0.9V _{DD}	0.25	0.5	—	mA
		5V	V _{OH} =0.9V _{DD}	0.5	1.0	—	mA
R _{PH}	Pull-high Resistance	3V	—	20	60	100	kΩ
		5V	—	10	30	50	kΩ
V _{BIAS}	0.5V _{DD} Bias Voltage (see note 3)	5V		2.3	2.5	2.7	V
V _{AD}	A/D Input Voltage	—	—	0	—	V _{REF}	V
V _{REF}	A/D Input Reference Voltage Range	—	V _{AVDD} =2.7V~5.5V	1.6	—	V _{AVDD} +0.1	V
DNL	A/D Differential Non-Linearity	—	V _{AVDD} =5V, V _{REF} =V _{AVDD} , t _{AD} =0.5μs	-2	—	2	LSB
INL	A/D Integral Non-Linearity	—		-4	—	4	LSB
I _{ADC}	Additional Power Consumption if A/D Converter is Used	3V	—	—	0.5	1.0	mA
		5V	—	—	1.5	3.0	mA

- Note:
- * RTC OSC in slow mode for test condition.
 - set "LCDEN"=1, set "COM0EN"=1, reset "RSEL"=0 in LCDC (1FH) register for I_{STB5} measurement.
 - V_{BIAS} voltage is design guarantee. Not for test.
 - V_{AVDD} is the analog circuit supply voltage which does not have an external pin but is connected to V_{DD} inside the device.

A.C. Characteristics

Ta=25°C

Symbol	Parameter	Test Conditions		Min.	Typ.	Max.	Unit
		V _{DD}	Conditions				
f _{SYS1}	System Clock (RC OSC)	—	2.2V~5.5V	400	—	4000	kHz
		—	3.3V~5.5V	400	—	8000	kHz
f _{SYS2}	System Clock (RTC OSC)	—	2.2V~5.5V	—	32768	—	kHz
f _{TIMER}	Timer I/P Frequency (TMR)	—	2.2V~5.5V	0	—	4000	kHz
		—	3.3V~5.5V	0	—	8000	kHz
t _{WDTOSC}	Watchdog Oscillator Period	3V	—	45	90	180	μs
		5V	—	32	65	130	μs
f _{FSP1}	f _{SP} Time-out Period Clock Source form WDT	3V	With prescaler (f _S /4096)	184	369	737	ms
		5V		131	266	532	ms
t _{FSP2}	f _{SP} Time-out Period Clock Source form RTC	—	With prescaler (f _S /4096)	—	125	—	ms
t _{RES}	External Reset Low Pulse Width	—	—	1	—	—	μs
t _{SST}	System Start-up Timer Period	—	Wake-up from HALT	—	1024	—	*t _{SYS}
t _{LVR}	Low Voltage Reset Time	—	—	0.25	1	2	ms
t _{INT}	Interrupt Pulse Width	—	—	1	—	—	μs
t _{AD}	A/D Clock Period	—	—	0.5	—	—	μs
t _{ADC}	A/D Conversion Time	—	—	—	16	—	t _{AD}

 Note: *t_{SYS}=1/f_{SYS1} or 1/f_{SYS2}

System Architecture

A key factor in the high-performance features of the Holtek microcontrollers is attributed to the internal system architecture. The range of devices take advantage of the usual features found within RISC microcontrollers providing increased speed of operation and enhanced performance. The pipelining scheme is implemented in such a way that instruction fetching and instruction execution are overlapped, hence instructions are effectively executed in one cycle, with the exception of branch or call instructions. An 8-bit wide ALU is used in practically all operations of the instruction set. It carries out arithmetic operations, logic operations, rotation, increment, decrement, branch decisions, etc. The internal data path is simplified by moving data through the Accumulator and the ALU. Certain internal registers are implemented in the Data Memory and can be directly or indirectly addressed. The simple addressing methods of these registers along with additional architectural features ensure that a minimum of external components is required to provide a functional I/O and A/D control system with maximum reliability and flexibility.

Clocking and Pipelining

The main system clock, derived from either a Crystal/Resonator or RC oscillator is subdivided into four internally generated non-overlapping clocks, T1~T4. The Program Counter is incremented at the beginning of the T1 clock during which time a new instruction is fetched. The remaining T2~T4 clocks carry out the decoding and execution functions. In this way, one T1~T4 clock cycle forms one instruction cycle. Although the fetching and

execution of instructions takes place in consecutive instruction cycles, the pipelining structure of the microcontroller ensures that instructions are effectively executed in one instruction cycle. The exception to this are instructions where the contents of the Program Counter are changed, such as subroutine calls or jumps, in which case the instruction will take one more instruction cycle to execute.

When the RC oscillator is used, OSC2 is freed for use as a T1 phase clock synchronising pin. This T1 phase clock has a frequency of $f_{SYS}/4$ with a 1:3 high/low duty cycle.

For instructions involving branches, such as jump or call instructions, two machine cycles are required to complete instruction execution. An extra cycle is required as the program takes one cycle to first obtain the actual jump or call address and then another cycle to actually execute the branch. The requirement for this extra cycle should be taken into account by programmers in timing sensitive applications

Program Counter

During program execution, the Program Counter is used to keep track of the address of the next instruction to be executed. It is automatically incremented by one each time an instruction is executed except for instructions, such as "JMP" or "CALL" that demand a jump to a non-consecutive Program Memory address. However, it must be noted that only the lower 8 bits, known as the Program Counter Low Register, are directly addressable by user.

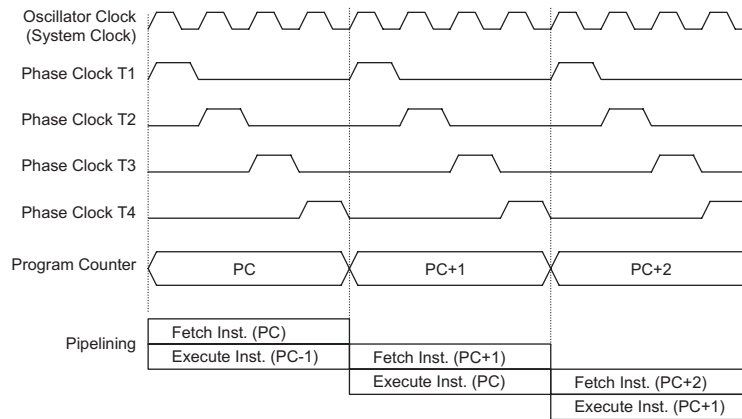

System Clocking and Pipelining

1	MOV A,[12H]
2	CALL DELAY
3	CPL [12H]
4	:
5	:
6	DELAY: NOP

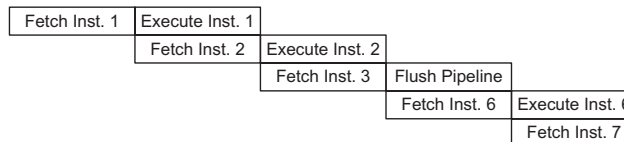

Instruction Fetching

When executing instructions requiring jumps to non-consecutive addresses such as a jump instruction, a subroutine call, interrupt or reset, etc., the microcontroller manages program control by loading the required address into the Program Counter. For conditional skip instructions, once the condition has been met, the next instruction, which has already been fetched during the present instruction execution, is discarded and a dummy cycle takes its place while the correct instruction is obtained.

The lower byte of the Program Counter, known as the Program Counter Low register or PCL, is available for program control and can be read nor written to. By transferring data directly into this register, a short program jump can be executed directly, however, as only this low byte is available for manipulation, the jumps are limited to the present page of memory, that is 256 locations. When such program jumps are executed it should also be noted that a dummy cycle will be inserted.

The lower byte of the Program Counter is fully accessible under program control. Manipulating the PCL might cause program branching, so an extra cycle is needed to pre-fetch. Further information on the PCL register can be found in the Special Function Register section.

Stack

This is a special part of the memory which is used to save the contents of the Program Counter only. The stack is organised into 8 levels and is neither part of the

data nor part of the program space, and is neither be read nor written to. The activated level is indexed by the Stack Pointer, SP, and can neither be read nor written to. At a subroutine call or interrupt acknowledge signal, the contents of the Program Counter are pushed onto the stack. At the end of a subroutine or an interrupt routine, signaled by a return instruction, RET or RETI, the Program Counter is restored to its previous value from the stack. After a device reset, the Stack Pointer will point to the top of the stack.

If the stack is full and an enabled interrupt takes place, the interrupt request flag will be recorded but the acknowledge signal will be inhibited. When the Stack Pointer is decremented, by RET or RETI, the interrupt will be serviced. This feature prevents stack overflow allowing the programmer to use the structure more easily. However, when the stack is full, a CALL subroutine instruction can still be executed which will result in a stack overflow. Precautions should be taken to avoid such cases which might cause unpredictable program branching.

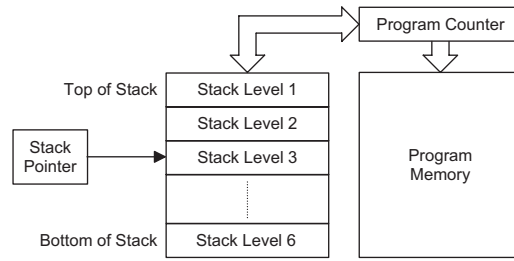

Mode	Program Counter Bits										
	b10	b9	b8	b7	b6	b5	b4	b3	b2	b1	b0
Initial Reset	0	0	0	0	0	0	0	0	0	0	0
External Interrupt	0	0	0	0	0	0	0	0	1	0	0
Timer/Event Counter Overflow	0	0	0	0	0	0	0	1	0	0	0
Time Base Interrupt	0	0	0	0	0	0	0	1	1	0	0
A/D Converter Interrupt	0	0	0	0	0	0	1	0	0	0	0
Skip	Program Counter + 2										
Loading PCL	PC10	PC9	PC8	@7	@6	@5	@4	@3	@2	@1	@0
Jump, Call Branch	#10	#9	#8	#7	#6	#5	#4	#3	#2	#1	#0
Return from Subroutine	S10	S9	S8	S7	S6	S5	S4	S3	S2	S1	S0

Program Counter

Note: PC10~PC8: Current Program Counter bits
 @7~@0: PCL bits
 #10~#0: Instruction code address bits
 S10~S0: Stack register bits
 The Program Counter is 11 bits wide, i.e. from b10~b0.

Arithmetic and Logic Unit – ALU

The arithmetic-logic unit or ALU is a critical area of the microcontroller that carries out arithmetic and logic operations of the instruction set. Connected to the main microcontroller data bus, the ALU receives related instruction codes and performs the required arithmetic or logical operations after which the result will be placed in the specified register. As these ALU calculation or operations may result in carry, borrow or other status changes, the status register will be correspondingly updated to reflect these changes. The ALU supports the following functions:

- Arithmetic operations: ADD, ADDM, ADC, ADCM, SUB, SUBM, SBC, SBCM, DAA
- Logic operations: AND, OR, XOR, ANDM, ORM, XORM, CPL, CPLA
- Rotation RRA, RR, RRCA, RRC, RLA, RL, RLCA, RLC
- Increment and Decrement INCA, INC, DECA, DEC
- Branch decision, JMP, SZ, SZA, SNZ, SIZ, SDZ, SIZA, SDZA, CALL, RET, RETI

Program Memory

The Program Memory is the location where the user code or program is stored. For this device, the type of memory is One-Time Programmable, OTP, memory where users can program their application code into the device. By using the appropriate programming tools, OTP devices offer users the flexibility to freely develop their applications which may be useful during debug or for products requiring frequent upgrades or program changes. OTP devices are also applicable for use in applications that require low or medium volume production runs.

Structure

The Program Memory has a capacity of 2K by 14 bits. The Program Memory is addressed by the Program Counter and also contains data, table information and interrupt entries. Table data, which can be setup in any location within the Program Memory, is addressed by separate table pointer registers.

Special Vectors

Within the Program Memory, certain locations are reserved for special usage such as reset and interrupts.

- Location 000H
This vector is reserved for use by the device reset for program initialisation. After a device reset is initiated, the program will jump to this location and begin execution.
- Location 004H
This vector is used by the external interrupt. If the external interrupt pin on the device receives a rising or falling transition, the program will jump to this location and begin execution if the external interrupt is enabled and the stack is not full.

- Location 008H
This internal vector is used by the Timer/Event Counter 0. If a counter overflow occurs, the program will jump to this location and begin execution if the timer/event counter interrupt is enabled and the stack is not full.
- Location 00CH
This internal vector is used by the Time Base interrupt. If a Time Base interrupt occurs, the program will jump to this location and begin execution if the time base interrupt is enabled and the stack is not full.
- Location 010H
This internal vector is used by the A/D converter. When an A/D conversion cycle is complete, the program will jump to this location and begin execution if the A/D interrupt is enabled and the stack is not full.

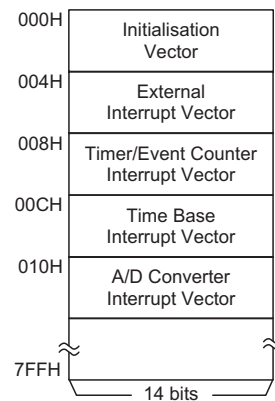

Program Memory Structure

Look-up Table

Any location within the Program Memory can be defined as a look-up table where programmers can store fixed data. To use the look-up table, the table pointer must first be setup by placing the lower order address of the look up data to be retrieved in the table pointer register, TBLP. This register defines the lower 8-bit address of the look-up table.

After setting up the table pointer, the table data can be retrieved from the current Program Memory page or last Program Memory page using the "TABRDC[m]" or "TABRDL [m]" instructions, respectively. When these instructions are executed, the lower order table byte from the Program Memory will be transferred to the user defined Data Memory register [m] as specified in the instruction. The higher order table data byte from the Program Memory will be transferred to the TBLH special register. Any unused bits in this transferred higher order byte will be read as "0".

The accompanying diagram illustrates the addressing/data flow of the look-up table:

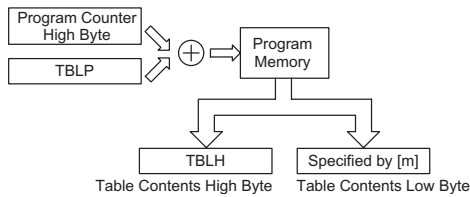

Table Program Example

The following example shows how the table pointer and table data is defined and retrieved from the microcontroller. This example uses raw table data located in the last page which is stored there using the

ORG statement. The value at this ORG statement is "700H" which refers to the start address of the last page within the 2K Program Memory. The table pointer is setup here to have an initial value of "06H". This will ensure that the first data read from the data table will be at the Program Memory address "706H" or 6 locations after the start of the last page. Note that the value for the table pointer is referenced to the first address of the present page if the "TABRDC [m]" instruction is being used. The high byte of the table data which in this case is equal to zero will be transferred to the TBLH register automatically when the "TABRDL [m]" instruction is executed.

```

tempreg1 db ? ; temporary register #1
tempreg2 db ? ; temporary register #2
:
:
mov a,06h ; initialise table pointer - note that this address
; is referenced
mov tblp,a ; to the last page or present page
:
:
tabrdl tempreg1 ; transfers value in table referenced by table pointer
; to tempreg1
; data at prog.memory address "706H" transferred to
; tempreg1 and TBLH
dec tblp ; reduce value of table pointer by one
tabrdl tempreg2 ; transfers value in table referenced by table pointer
; to tempreg2
; data at prog.memory address "705H" transferred to
; tempreg2 and TBLH
; in this example the data "1AH" is transferred to
; tempreg1 and data "0FH" to register tempreg2
; the value "00H" will be transferred to the high byte
; register TBLH
:
:
org 700h ; sets initial address of last page
dc 00Ah, 00Bh, 00Ch, 00Dh, 00Eh, 00Fh, 01Ah, 01Bh
:
:
  
```

Instruction	Table Location Bits										
	b10	b9	b8	b7	b6	b5	b4	b3	b2	b1	b0
TABRDC [m]	PC10	PC9	PC8	@7	@6	@5	@4	@3	@2	@1	@0
TABRDL [m]	1	1	1	@7	@6	@5	@4	@3	@2	@1	@0

Table Location

Note: PC10~PC8: Current Program Counter bits
 @7~@0: Table Pointer TBLP bits
 The Table address location is 11 bits, i.e. from b10~b0.

Because the TBLH register is a read-only register and cannot be restored, care should be taken to ensure its protection if both the main routine and Interrupt Service Routine use table read instructions. If using the table read instructions, the Interrupt Service Routines may change the value of the TBLH and subsequently cause errors if used again by the main routine. As a rule it is recommended that simultaneous use of the table read instructions should be avoided. However, in situations where simultaneous use cannot be avoided, the interrupts should be disabled prior to the execution of any main routine table-read instructions. Note that all table related instructions require two instruction cycles to complete their operation.

Data Memory

The Data Memory is a volatile area of 8-bit wide RAM internal memory and is the location where temporary information is stored. Divided into two sections, the first of these is an area of RAM where special function registers are located. These registers have fixed locations and are necessary for correct operation of the device. Many of these registers can be read from and written to directly under program control, however, some remain

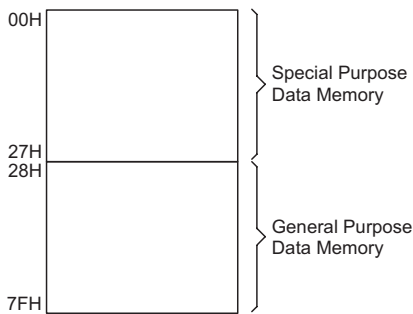

Data Memory Structure

Note: Most of the Data Memory bits can be directly manipulated using the "SET [m].i" and "CLR [m].i" with the exception of a few dedicated bits. The Data Memory can also be accessed through the memory pointer registers MP0 and MP1.

protected from user manipulation. The second area of Data Memory is reserved for general purpose use. All locations within this area are read and write accessible under program control.

Structure

The two sections of Data Memory, the Special Purpose and General Purpose Data Memory are located at consecutive locations. All are implemented in RAM and are

8 bits wide but the length of each memory section is dictated by the type of microcontroller chosen. The start address of the Data Memory for all devices is the address "00H". Registers which are common to all microcontrollers, such as ACC, PCL, etc., have the same Data Memory address.

General Purpose Data Memory

All programs require an area of read/write memory where temporary data can be stored and retrieved for use later. It is this area of RAM memory that is known as General Purpose Data Memory. This area of Data Memory is fully accessible by the user program for both read and write operations. By using the "SET [m].i" and "CLR [m].i" instructions individual bits can be set or reset under program control giving the user a large range of flexibility for bit manipulation in the Data Memory.

00H	IAR0
01H	MP0
02H	IAR1
03H	MP1
04H	
05H	ACC
06H	PCL
07H	TBLP
08H	TBLH
09H	
0AH	STATUS
0BH	INTC0
0CH	
0DH	TMR
0EH	TMRC
0FH	
10H	
11H	
12H	PA
13H	PAC
14H	PB
15H	PBC
16H	PC
17H	
18H	PD
19H	
1AH	PE
1BH	PWM0
1CH	PWM1
1DH	
1EH	INTC1
1FH	LCDC
20H	MODE
21H	
22H	
23H	
24H	ADRL
25H	ADRH
26H	ADCR
27H	ACSR

 : Unused, read as "00"

Special Purpose Data Memory

Special Purpose Data Memory

This area of Data Memory is where registers, necessary for the correct operation of the microcontroller, are stored. Most of the registers are both readable and writeable but some are protected and are readable only, the details of which are located under the relevant Special Function Register section. Note that for locations that are unused, any read instruction to these addresses will return the value "00H".

Special Function Registers

To ensure successful operation of the microcontroller, certain internal registers are implemented in the Data Memory area. These registers ensure correct operation of internal functions such as timers, interrupts, etc., as well as external functions such as I/O data control and A/D converter operation. The location of these registers within the Data Memory begins at the address 00H. Any unused Data Memory locations between these special function registers and the point where the General Purpose Memory begins is reserved for future expansion purposes, attempting to read data from these locations will return a value of 00H.

Indirect Addressing Registers – IAR0, IAR1

The IAR0 and IAR1 registers, located at Data Memory addresses 00H and 02H, are not physically implemented. These special function registers allows what is known as indirect addressing, which permits data manipulation using Memory Pointers instead of the usual direct memory addressing method where the actual memory address is defined. Any actions on the IAR0 and IAR1 registers will result in corresponding read/write operations to the memory locations specified by the Memory Pointers MP0 and MP1. Reading the IAR0 and IAR1 registers indirectly will return a result of "00H" and writing to the register indirectly will result in no operation.

Memory Pointer – MP0, MP1

Two Memory Pointers, known as MP0 and MP1, are physically implemented in Data Memory. The Memory Pointer can be written to and manipulated in the same way as normal registers providing an easy way of addressing and tracking data. When using any operation on the indirect addressing register IAR0 or IAR1, it is actually the address specified by the Memory Pointer that the microcontroller will be directed to.

The following example shows how to clear a section of four RAM locations already defined as locations adres1 to adres4.

```
data .section 'data'
adres1      db ?
adres2      db ?
adres3      db ?
adres4      db ?
block       db ?
code .section at 0 'code'
org 00h

start:
    mov a,04h           ; setup size of block
    mov block,a
    mov a,offset adres1 ; Accumulator loaded with first RAM address
    mov mp0,a          ; setup memory pointer with first RAM address

loop:
    clr IAR0           ; clear the data at address defined by MP0
    inc mp0            ; increment memory pointer
    sdz block          ; check if last memory location has been cleared
    jmp loop

continue:
```

The important point to note here is that in the example shown above, no reference is made to specific RAM addresses.

Accumulator – ACC

The Accumulator is central to the operation of any microcontroller and is closely related with operations carried out by the ALU. The Accumulator is the place where all intermediate results from the ALU are stored. Without the Accumulator it would be necessary to write the result of each calculation or logical operation such as addition, subtraction, shift, etc., to the Data Memory resulting in higher programming and timing overheads. Data transfer operations usually involve the temporary storage function of the Accumulator; for example, when transferring data between one user defined register and another, it is necessary to do this by passing the data through the Accumulator as no direct transfer between two registers is permitted.

Program Counter Low Register – PCL

To provide additional program control functions, the low byte of the Program Counter is made accessible to programmers by locating it within the Special Purpose area of the Data Memory. By manipulating this register, direct jumps to other program locations are easily implemented. Loading a value directly into this PCL register will cause a jump to the specified Program Memory location, however, as the register is only 8-bit wide, only jumps within the current Program Memory page are permitted. When such operations are used, note that a dummy cycle will be inserted.

Look-up Table Registers – TBLP, TBLH

These two special function registers are used to control operation of the look-up table which is stored in the Program Memory. TBLP is the table pointer and indicates the location where the table data is located. Its value must be setup before any table read commands are executed. Its value can be changed, for example using the "INC" or "DEC" instructions, allowing for easy table data pointing and reading. TBLH is the location where the high order byte of the table data is stored after a table read data instruction has been executed. Note that the lower order table data byte is transferred to a user defined location.

Status Register – STATUS

This 8-bit register contains the zero flag (Z), carry flag (C), auxiliary carry flag (AC), overflow flag (OV), power down flag (PDF), and watchdog time-out flag (TO). These arithmetic/logical operation and system management flags are used to record the status and operation of the microcontroller.

With the exception of the TO and PDF flags, bits in the status register can be altered by instructions like most other registers. Any data written into the status register will not change the TO or PDF flag. In addition, operations related to the status register may give different results due to the different instruction operations. The TO flag can be affected only by a system power-up, a WDT time-out or by executing the "CLR WDT" or "HALT" instruction. The PDF flag is affected only by executing the "HALT" or "CLR WDT" instruction or during a system power-up.

The Z, OV, AC and C flags generally reflect the status of the latest operations.

- **C** is set if an operation results in a carry during an addition operation or if a borrow does not take place during a subtraction operation; otherwise C is cleared. C is also affected by a rotate through carry instruction.
- **AC** is set if an operation results in a carry out of the low nibbles in addition, or no borrow from the high nibble into the low nibble in subtraction; otherwise AC is cleared.
- **Z** is set if the result of an arithmetic or logical operation is zero; otherwise Z is cleared.
- **OV** is set if an operation results in a carry into the highest-order bit but not a carry out of the highest-order bit, or vice versa; otherwise OV is cleared.
- **PDF** is cleared by a system power-up or executing the "CLR WDT" instruction. PDF is set by executing the "HALT" instruction.
- **TO** is cleared by a system power-up or executing the "CLR WDT" or "HALT" instruction. TO is set by a WDT time-out.

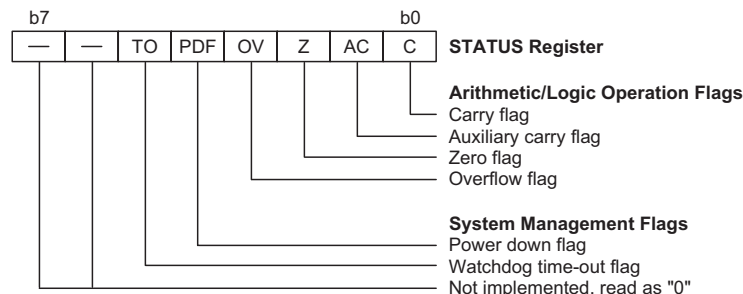

Status Register

In addition, on entering an interrupt sequence or executing a subroutine call, the status register will not be pushed onto the stack automatically. If the contents of the status registers are important and if the subroutine can corrupt the status register, precautions must be taken to correctly save it.

Interrupt Control Registers – INTC0, INTC1

These 8-bit registers, known as INTC0 and INTC1, control the operation of both the external and internal interrupts. By setting various bits within these registers using standard bit manipulation instructions, the enable/disable function of the external interrupts and each of the internal interrupts can be independently controlled. A master interrupt bit within these registers, the EMI bit, acts like a global enable/disable and is used to set all of the interrupt enable bits on or off. This bit is cleared when an interrupt routine is entered to disable further interrupt and is set by executing the RETI" instruction.

Timer/Event Counter Registers – TMR, TMRC

The device contains one integrated 8-bit count up Timer/Event Counter. It has associated registers known as TMR, where the timer's values are located. One associated control register, known as TMRC contains the setup information for the timer. Note that all timer registers can be directly written to in order to preload their contents with fixed data to allow different time intervals to be setup.

Input/Output Ports and Control Registers

Within the area of Special Function Registers, the I/O registers and their associated control registers play a prominent role. All I/O and output ports have a designated register correspondingly labeled as PA, PB, PC, PD and PE. These labeled I/O registers are mapped to specific addresses within the Data Memory as shown in the Data Memory table, which are used to transfer the appropriate output or input data on that port. For the I/O ports, PA and PB, there is an associated control register labeled PAC and PBC, also mapped to specific addresses with the Data Memory. The control register specifies which pins of that port are set as inputs and which are set as outputs. To setup a pin as an input, the corresponding bit of the control register must be set high, for an output it must be set low. During program initialisation, it is important to first setup the control registers to specify which pins are outputs and which are inputs before reading data from or writing data to the I/O ports. One flexible feature of these registers is the ability to directly program single bits using the "SET [m].i" and "CLR [m].i" instructions. The ability to change I/O pins from output to input and vice versa by manipulating specific bits of the I/O control registers during normal program operation is a useful feature of these devices.

PC, PD and PE are output ports only and therefore do not have control registers.

Setting its output register high which effectively places its NMOS output transistor in high impedance state. Resetting output register to low will force to output low state.

Pulse Width Modulator Registers – PWM0, PWM1

The device contains two Pulse Width Modulators. Each one has its own related independent control register, with the names, PWM0 and PWM1. The 8-bit contents of these registers, defines the duty cycle value for the modulation cycle of the corresponding Pulse Width Modulator.

A/D Converter Registers – ADRL, ADRH, ADCR, ACSR

The device contains a 6-channel 12-bit A/D converter. The correct operation of the A/D requires the use of two data registers, a control register and a clock source register. A high byte data register known as ADRH, and a low byte data register known as ADRL. These are the register locations where the digital value is placed after the completion of an analog to digital conversion cycle. The channel selection and configuration of the A/D converter is setup via the control register ADCR while the A/D clock frequency is defined by the clock source register, ACSR.

Mode Register – MODE

The Mode Register is used to select the Mode of Operation which can be either Normal, Slow or Power-down. It also contains a bit to control the quick start up function of the 32768Hz oscillator.

LCD Control Register – LCDC

The LCDC register is used to setup various functions for the LCD display. Functions such as 1/2 bias enable for each COM line, bias resistor and LCD enable are setup with this register.

Input/Output Ports

Holtek microcontrollers offer considerable flexibility on their I/O ports. With the input or output designation of PA, PB pin fully under user program control, pull-high options and wake-up options on PA pins, the user is provided with an I/O structure to meet the needs of a wide range of application possibilities.

The device offers up to 16 bidirectional input/output lines on ports PA and PB. There are also outputs on ports PC, PD and PE. These I/O ports are mapped to the Data Memory with specific addresses as shown in the Special Purpose Data Memory table. For input operation, these ports are non-latching, which means the inputs must be ready at the T2 rising edge of instruction

"MOV A,[m]", where m denotes the port address. For output operation, all the data is latched and remains unchanged until the output latch is rewritten.

Pull-high Resistors

Many product applications require pull-high resistors for their switch inputs usually requiring the use of an external resistor. To eliminate the need for these external resistors, all pins on Port A, when configured as an input have the capability of being connected to an internal pull-high resistor. These pull-high resistors are selectable via a configuration option and are implemented using a weak PMOS transistor.

Port A Wake-up

Each device has a HALT instruction enabling the microcontroller to enter a Power Down Mode and preserve power, a feature that is important for battery and other low-power applications. Various methods exist to wake-up the microcontroller, one of which is to change the logic condition on one of the Port A pins from high to low. After a HALT instruction forces the microcontroller into entering a Power Down condition, the device will remain in a low-power state until a Port A pin receives a high to low going edge. This function is especially suitable for applications that can be woken up via external switches. Note that each pin on Port A can be selected individually to have this wake-up feature.

I/O Port Control Registers

As PA and PB are I/O ports, they each have a port control register, known as PAC and PBC, to control the input/output configuration. With these control registers, each CMOS output or input on these ports with or without pull-high resistor structures can be reconfigured dynamically under configuration option. Each pin of the I/O ports is directly mapped to a bit in its associated port control register. For the I/O pin to function as an input, the corresponding bit of the control register must be written as a "1". This will then allow the logic state of the input pin to be directly read by instructions. When the corresponding bit of the control register is written as a "0", the I/O pin will be setup as a CMOS output. If the pin is currently setup as an output, instructions can still be used to read the output register. However, it should be noted that the program will in fact only read the status of the output data latch and not the actual logic status of the output pin.

Pin-shared Functions

The flexibility of the microcontroller range is greatly enhanced by the use of pins that have more than one function. Limited numbers of pins can force serious design constraints on designers but by supplying pins with

multi-functions, many of these difficulties can be overcome. For some pins, the chosen function of the multi-function I/O pins is set by configuration options while for others the function is set by application program control.

- External Interrupt Input

The external dual edge triggered interrupt pin INT is pin-shared with the output pin PD0. The pin can be configured as an external interrupt pin if the corresponding external interrupt enable bit in the INTC0 register has been set and the PD0 output is disabled by setting the LCDEN bit in the LCDDC register to zero and the PD0 bit set high. If the external interrupt enable bit is not set then the pin can be used as a PD0 CMOS output pin.

- External Timer Clock Input

The external timer pin TMR is pin-shared with the I/O pins PA2. To configure this pin to operate as timer input, the corresponding control bits in the timer control register must be correctly set. For applications that do not require an external timer input, this pin can be used as normal I/O pin. Note that if used as normal I/O pin the timer mode control bits in the timer control register must select the timer mode, which has an internal clock source, to prevent the input pin from interfering with the timer operation.

- PWM Outputs

The devices contain two PWM outputs PWM0 and PWM1 are pin shared with pins PA4 and PA5, respectively. The PWM output functions are chosen via configuration options and remain fixed after the device is programmed. Note that the corresponding bit or bits of the port control register, PAC, must setup the pin as an output to enable the PWM output. If the PAC port control register has setup the pin as an input, then the pin will function as a normal logic input with the usual pull-high option, even if the PWM configuration option has been selected.

- A/D Inputs

The device has 6 A/D converter inputs. All of these analog inputs are pin-shared with I/O pins on Port B. If these pins are to be used as A/D inputs and not as normal I/O pins then the corresponding bits in the A/D Converter Control Register, ADCR, must be properly set. There are no configuration options associated with the A/D function. If used as I/O pins, then full pull-high resistor configuration options remain, however if used as A/D inputs then any pull-high resistor options associated with these pins will be automatically disconnected.

I/O Pin Structures

The following diagrams illustrate the I/O pin internal structures. As the exact logical construction of the I/O pin may differ from these drawings, they are supplied as a guide only to assist with the functional understanding of the I/O pins.

Programming Considerations

Within the user program, one of the first things to consider is port initialisation. After a reset, all of the I/O data (except PC) and port control registers will be set high. This means that all of the PC, PD and PE output pins will be in a output floating condition. Also all the PA and PB I/O pins will default to an input state, the level of which depends on the other connected circuitry and whether pull-high options have been selected. If the port control registers, PAC and PBC, are then programmed to setup some pins as outputs, these output pins will have an initial high output value unless the associated port data registers, PA and PB, are first programmed. Selecting which pins are inputs and which are outputs can be achieved byte-wide by loading the correct values into

the appropriate port control register or by programming individual bits in the port control register using the "SET [m].i" and "CLR [m].i" instructions. Note that when using these bit control instructions, a read-modify-write operation takes place. The microcontroller must first read in the data on the entire port, modify it to the required new bit values and then rewrite this data back to the output ports.

Port A has the additional capability of providing wake-up functions. When the device is in the Power Down Mode, various methods are available to wake the device up. One of these is a high to low transition of any of the Port A pins. Single or multiple pins on Port A can be setup to have this function.

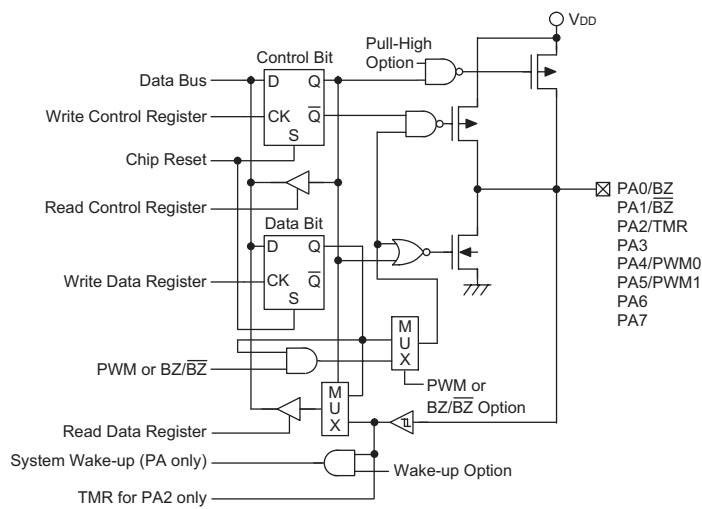

PA Input/Output Ports

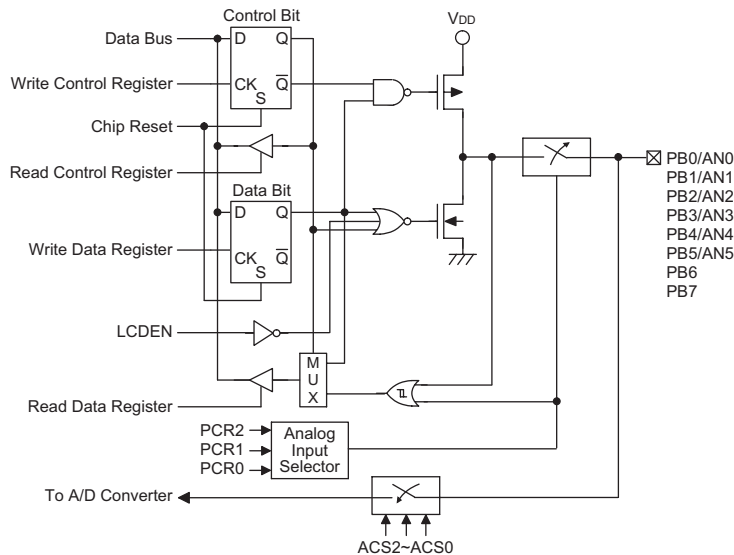

PB Input/Output Ports

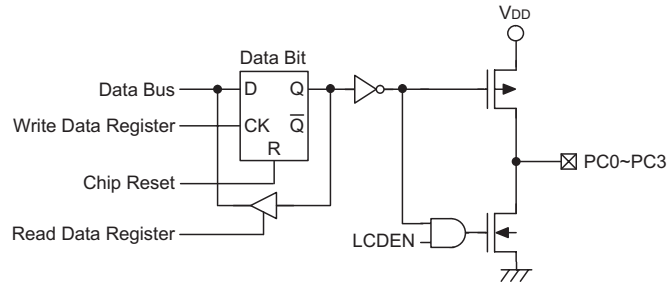

PC0~PC3 Output Ports

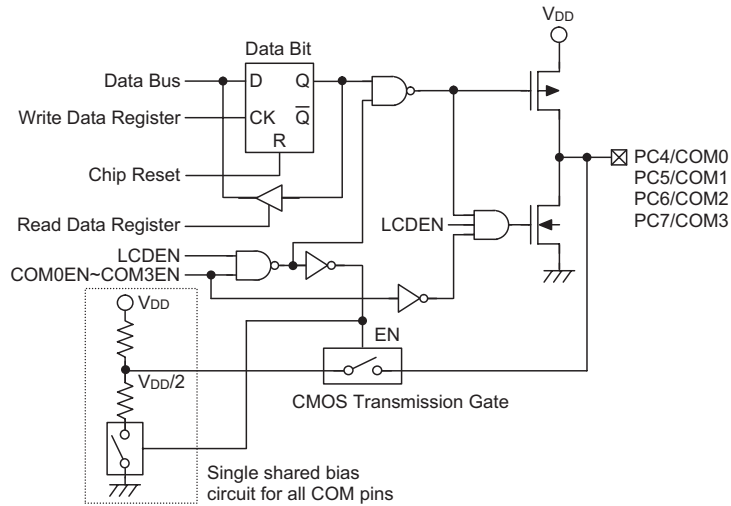

PC4~PC7 Output Ports

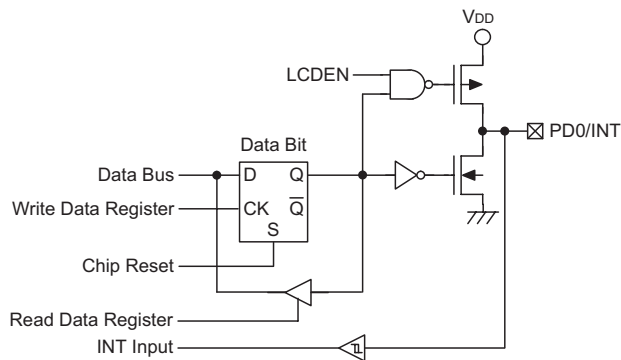

PD0 Input/Output Port

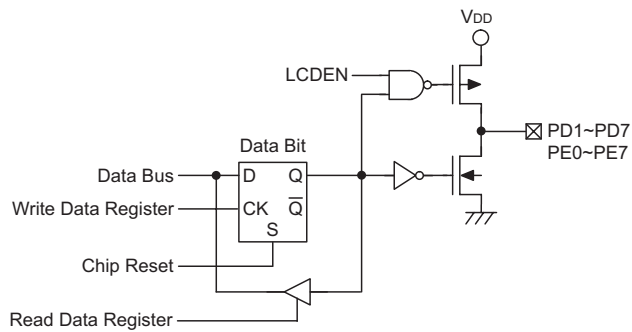

PD1~PD7, PE Output Ports

LCD Driver Function

The device contains circuitry to control an external LCD. This function is controlled using the LCDC register.

LCD Driver Operation

When the LCDEN bit in the LCDC register is set high and PB is configured as an output, ports PB, PC, PD and PE become CMOS outputs, but have lower sink/source capabilities making them suitable for LCD segment driving. Following a power-on reset, port PB will be setup as an input port, while PC is setup as a PMOS output port while PD and PE are setup as NMOS output ports, making them suitable for LED driving.

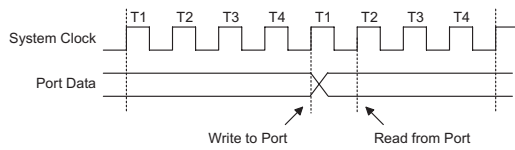

Read/Write Timing

However at this time, as the LCDEN bit is low, the PC, PD and PE outputs will be in an open-drain high-impedance condition. To setup ports PB~PE as CMOS outputs, the LCDEN bit must be set high. It is important to note that PB and PC have a lower sink ability (I_{OL2}) while PD and PE have a lower driving ability (I_{OH3}). The D.C. Characteristics provide for further information.

1/2 Bias LCD Control

As the device may be conveniently used for driving LCD panels, pins PC4~PC7 and other I/O ports can be used together to implement 1/2 bias LCD timing signals.

COM0~3 can be sourced from the PC4~7 pins while the SEGMENTS can be sourced from other I/O ports. The internal 1/2 bias circuit is enabled via a combination of the LCDEN and COM0EN~COM3EN bits in the LCDC register. The RSEL bit in the LCDC register selects the bias circuit resistor values which should be chosen according to the actual LCD panel used and to minimise current consumption. Note that there is only one bias circuit which is shared by all the COM outputs.

LCDC Register					1/2 Bias On/Off
LCDEN	COM3EN	COM2EN	COM1EN	COM0EN	
0	x	x	x	x	Off
1	0	0	0	0	Off
1	0	0	0	1	On
:	:	:	:	:	ON
:	:	:	:	:	ON
1	1	1	1	1	ON

1/2 Bias Circuit Control

The following steps can be used to implement LCD timing:

- Select the bias resistor by setting RSEL=0 or 1
- Set LCDEN=1
- Use software to generate the VDD, VSS, VDD/2 voltages by changing COM pins PC4~7 to output high, output low and input respectively.
- Generate the segment timing using other I/O ports with outputs equal to either VSS or VDD

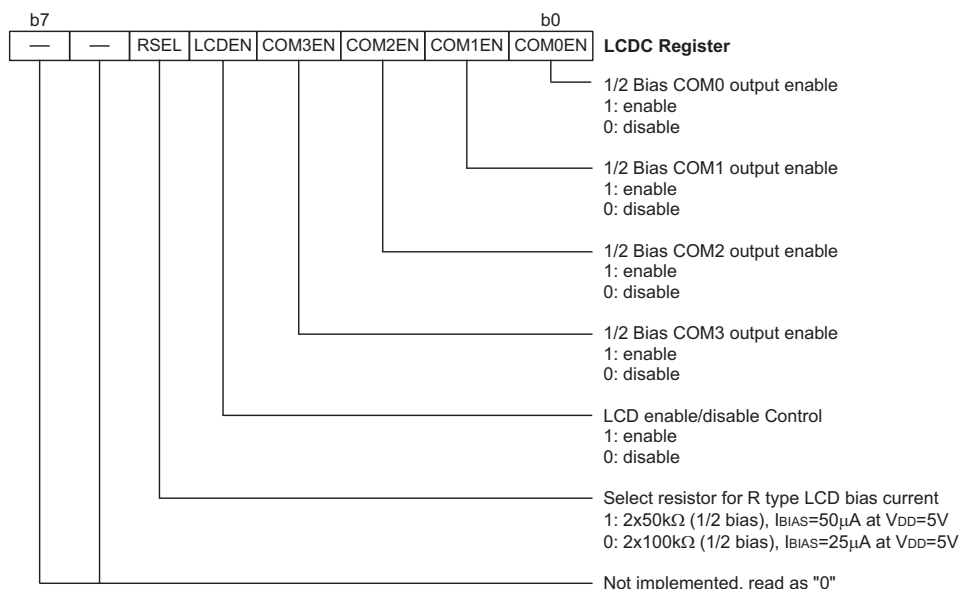

LCD Control Register

Timer/Event Counters

The provision of timers form an important part of any microcontroller, giving the designer a means of carrying out time related functions. The device contains one 8-bit count up timers. With three different operating modes, the timers can be configured to operate as a general timer, an external event counter or as a Pulse Width Measurement device. The provision of a prescaler in the input clock circuitry of each Timer/Event Counter gives added range to the timer.

There are two types of registers related to the Timer/Event Counter. The first is the register that contains the actual value of the timer and into which an initial value can be preloaded. Reading from this register retrieves the contents of the Timer/Event Counter. The second type of associated register is the timer control register which defines the timer options and determines how the timer is to be used. The devices can have the timer clock configured to come from the internal clock source. In addition, the timer clock source can also be configured to come from an external timer pin.

Configuring the Timer/Event Counter Input Clock Source

The internal timer's clock can originate from various sources, chosen via a configuration option. The internal clock input timer source is used when the timer is in the timer mode or in the pulse width measurement mode. The clock timer source is also first divided by a prescaler, the division ratio of which is conditioned by the timer control register bits PSC0~PSC2.

An external clock source is used when the timer is in the event counting mode, the clock source being provided on the external timer TMR pin. Depending upon the condition of the TE bit, each high to low, or low to high transition on the external timer pin will increment the counter by one.

Timer Register – TMR

The timer register are special function register location within the special purpose Data Memory where the actual timer value is stored. This register has the name TMR. The value in the timer registers increases by one each time an internal clock pulse is received or an exter-

nal transition occurs on the external timer pin. The timer will count from the initial value loaded by the preload register to the full count value of FFH at which point the timer overflows and an internal interrupt signal generated. The timer value will then be reset with the initial preload register value and continue counting. To achieve a maximum full range count of FFH the preload register must first be cleared to 00H. It should be noted that after power-on the preload register will be in an unknown condition. Note that if the Timer/Event Counter is not running and data is written to its preload register, this data will be immediately written into the actual counter. However, if the counter is enabled and counting, any new data written into the preload register during this period will remain in the preload register and will only be written into the actual counter the next time an overflow occurs.

Timer Control Register – TMRC

The flexible features of the Holtek microcontroller Timer/Event Counters enable them to operate in three different modes, the options of which are determined by the contents of their respective control register. The device contains one timer control register known as TMRC. It is the timer control register together with its corresponding timer registers that control the full operation of the Timer/Event Counters. Before the timer can be used, it is essential that the timer control register is fully programmed with the right data to ensure its correct operation, a process that is normally carried out during program initialisation.

To choose which of the three modes the timer is to operate in, either in the timer mode, the event counting mode or the Pulse Width Measurement mode, bits 7 and 6 of the Timer Control Register, which are known as the bit pair TM1/TM0 respectively, must be set to the required logic levels. The timer-on bit, which is bit 4 of the Timer Control Register and known as TON, provides the basic on/off control of the respective timer. Setting the bit high allows the counter to run, clearing the bit stops the counter. The Timer/Event Counters also contains a prescaler function, with bits 0~2 of the associated Timer Control Register determining the division ratio of the input clock.

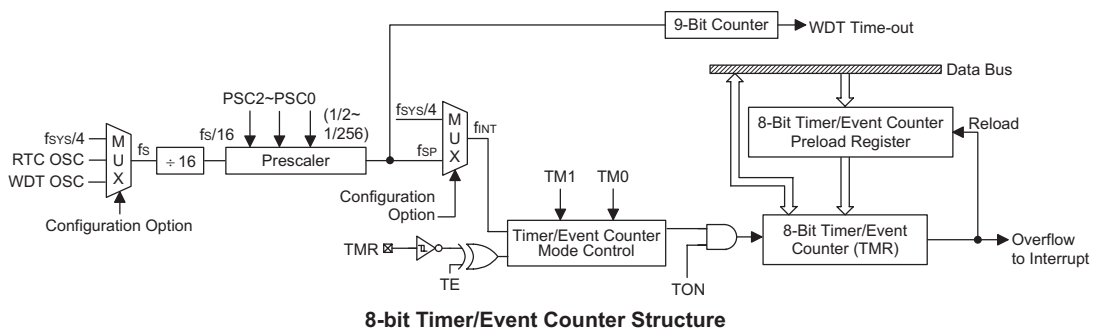

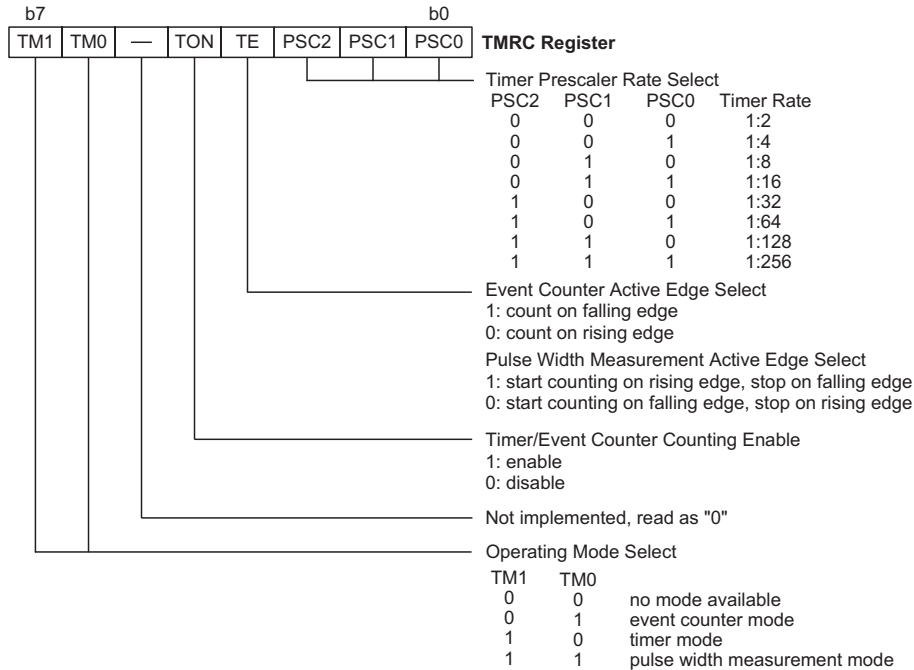

Timer/Event Counter Control Register

The prescaler bit settings have no effect if an external clock source is used. If the timer is in the Event Count or Pulse Width Measurement mode, the active transition edge level type is selected by the logic level of bit 3 of the Timer Control Register which is known as TE.

Configuring the Timer Mode

In this mode, the Timer/Event Counter can be utilised to measure fixed time intervals, providing an internal interrupt signal each time the counter overflows. To operate in this mode, the Operating Mode Select bit pair in the appropriate Timer Control Register must be set to the correct value as shown.

Control Register Operating Mode Select Bits for the Timer Mode

Bit7	Bit6
1	0

In this mode, a choice of internal clocks can be used as the Timer/Event Counter clock. However, this clock source is further divided by a prescaler, the value of which is determined by the Prescaler Rate Select bits, which are bits 0~2 in the respective Timer Control Register. After the other bits in the Timer Control Register have been setup, the enable bit, which is bit 4 of the Timer Control Register, can be set high to enable the Timer/Event Counter to run. Each time an internal clock

cycle occurs, the Timer/Event Counter increments by one. When it is full and overflows, an interrupt signal is generated and the Timer/Event Counter will reload the value already loaded into the preload register and continue counting. The interrupt can be disabled by ensuring that the Timer/Event Counter Interrupt Enable bit in the Interrupt Control Register, is reset to zero.

Configuring the Event Counter Mode

In this mode, a number of externally changing logic events, occurring on the external timer pins, can be recorded by the Timer/Event Counters. To operate in this mode, the Operating Mode Select bit pair in the appropriate Timer Control Register must be set to the correct value as shown.

Control Register Operating Mode Select Bits for the Event Counter Mode

Bit7	Bit6
0	1

In this mode the external timer pins are used as the Timer/Event Counter clock source, however it is not divided by the internal prescaler. After the other bits in the appropriate Timer Control Register have been setup, the enable bit, which is bit 4 of the Timer Control Register, can be set high to enable the Timer/Event Counter to run. If the Active Edge Select bit, which is bit 3 of the ap-

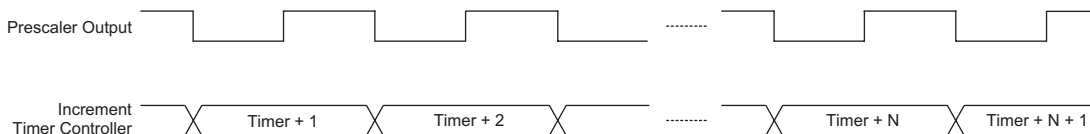

Timer Mode Timing Chart

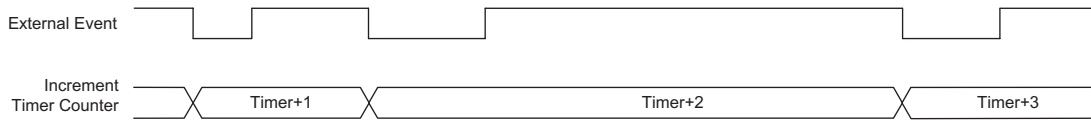

Event Counter Mode Timing Chart

appropriate Timer Control Register, is low, the Timer/EventCounter will increment each time the associated external timer pin receives a low to high transition. If the Active Edge Select bit is high, the Timer/Event Counter will increment each time the external timer pin receives a high to low transition. When it is full and overflows, an interrupt signal is generated and the Timer/Event Counter will reload the value already loaded into the preload register and continue counting. The interrupt can be disabled by ensuring that the associated Timer/Event Counter Interrupt Enable bit in the Interrupt Control Register, is reset to zero.

As the external timer pin is shared with an I/O pin, to ensure that the pin is configured to operate as an event counter input pin, two things have to happen. The first is to ensure that the Operating Mode Select bits in the Timer Control Register place the Timer/Event Counter in the Event Counting Mode, the second is to ensure that the port control register configures the pin as an input. It should be noted that in the event counting mode, even if the microcontroller is in the Power Down Mode, the Timer/Event Counter will continue to record externally changing logic events on the timer input pin. As a result when the timer overflows it will generate a timer interrupt and corresponding wake-up source.

Configuring the Pulse Width Measurement Mode

In this mode, the Timer/Event Counter can be utilised to measure the width of external pulses applied to the external timer pins. To operate in this mode, the Operating Mode Select bit pair in the appropriate Timer Control Register must be set to the correct value as shown.

Control Register Operating Mode Select Bits for the Pulse Width Measurement Mode

Bit7	Bit6
1	1

In this mode, a choice of internal clocks can be used as the Timer/Event Counter clock. However this clock source is further divided by a prescaler, the value of which is determined by the Prescaler Rate Select bits, which are bits 0~2 in the respective Timer Control Register. After the other bits in the appropriate Timer Control Register have been setup, the enable bit, which is bit 4 of the Timer Control Register, can be set high to enable the Timer/Event Counter, however it will not actually start counting until an active edge is received on the external timer pin.

If the Active Edge Select bit, which is bit 3 of the Timer Control Register, is low, once a high to low transition has been received on the related external timer pin, the Timer/Event Counter will start counting until the external timer pin returns to its original high level. At this point the enable bit will be automatically reset to zero and the Timer/Event Counter will stop counting. If the Active Edge Select bit is high, the Timer/Event Counter will begin counting once a low to high transition has been received on the external timer pin and stop counting when the external timer pin returns to its original low level. As before, the enable bit will be automatically reset to zero and the Timer/Event Counter will stop counting. It is important to note that in the Pulse Width Measurement Mode, the enable bit is automatically reset to zero when the external control signal on the external timer pin returns to its original level, whereas in the other two modes the enable bit can only be reset to zero under program control.

The residual value in the Timer/Event Counter, which can now be read by the program, therefore represents the length of the pulse received on the external timer pin. As the enable bit has now been reset, any further transitions on the external timer pin will be ignored. Not until the enable bit is again set high by the program can

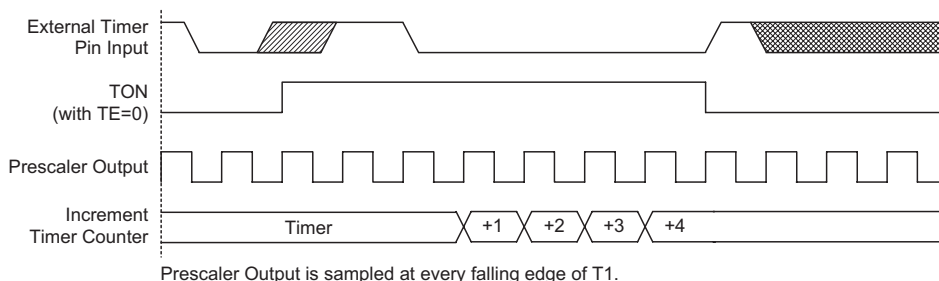

Pulse Width Measure Mode Timing Chart

the timer begin further pulse width measurements. In this way, single shot pulse measurements can be easily made.

It should be noted that in this mode the Timer/Event Counter is controlled by logical transitions on the external timer pin and not by the logic level. When the Timer/Event Counter is full and overflows, an interrupt signal is generated and the Timer/Event Counter will reload the value already loaded into the preload register and continue counting. The interrupt can be disabled by ensuring that the Timer/Event Counter Interrupt Enable bit in the Interrupt Control Register is reset to zero.

As the external timer pin is shared with an I/O pin, to ensure that the pin is configured to operate as pulse width measurement pins, two things have to happen. The first is to ensure that the Operating Mode Select bits in the Timer Control Register place the related Timer/Event Counter in the Pulse Width Measurement Mode. The second is to ensure that the port control register configures the timer pin as an input.

Prescaler

Bits PSC0~PSC2 of the TMRC register can be used to define the pre-scaling stages of the internal clock source for the Timer/Event Counters. In the Event Counter Mode the prescaler has no effect.

I/O Interfacing

The Timer/Event Counter, when configured to run in the Event Counter or Pulse Width Measurement Mode, requires the use of the external PA2/TMR pin for correct operation. As this pin is a shared pin it must be configured correctly to ensure it is setup for use as a Timer/Event Counter input and not as a normal I/O pin. This is implemented by ensuring that the mode select bits in the Timer/Event Counter control register, select either the Event Counter or Pulse Width Measurement Mode. Additionally the Port Control Register PAC bit 2 must be set high to ensure that the pin is setup as an input. Any pull-high resistor configuration option on this pin will remain valid even if the pin is used as a Timer/Event Counter input.

Programming Considerations

When configured to run in the timer mode, one of the internal clocks is used as the timer clock source and is therefore synchronised with the overall operation of the microcontroller. In this mode when the appropriate timer register is full, the microcontroller will generate an internal interrupt signal directing the program flow to the respective internal interrupt vector. For the pulse width measurement mode, one of the internal system clocks is also used as the timer clock source but the timer will

only run when the correct logic condition appears on the external timer input pin. As this is an external event and not synchronised with the internal timer clock, the microcontroller will only see this external event when the next timer clock pulse arrives. As a result, there may be small differences in measured values requiring programmers to take this into account during programming. The same applies if the timer is configured to be in the event counting mode, which again is an external event and not synchronised with the internal system or timer clock.

When the Timer/Event Counter is read, or if data is written to the preload register, the clock is inhibited to avoid errors, however as this may result in a counting error, this should be taken into account by the programmer. Care must be taken to ensure that the timers are properly initialised before using them for the first time. The associated timer enable bits in the interrupt control register must be properly set otherwise the internal interrupt associated with the timer will remain inactive. The edge select, timer mode and clock source control bits in timer control register must also be correctly set to ensure the timer is properly configured for the required application. It is also important to ensure that an initial value is first loaded into the timer registers before the timer is switched on; this is because after power-on the initial values of the timer registers are unknown. After the timer has been initialised the timer can be turned on and off by controlling the enable bit in the timer control register. Note that setting the timer enable bit high to turn the timer on, should only be executed after the timer mode bits have been properly setup. Setting the timer enable bit high together with a mode bit modification, may lead to improper timer operation if executed as a single timer control register byte write instruction.

When the Timer/Event counter overflows, its corresponding interrupt request flag in the interrupt control register will be set. If the timer interrupt is enabled this will in turn generate an interrupt signal. However irrespective of whether the interrupts are enabled or not, a Timer/Event counter overflow will also generate a wake-up signal if the device is in a Power-down condition. This situation may occur if the Timer/Event Counter is in the Event Counting Mode and if the external signal continues to change state. In such a case, the Timer/Event Counter will continue to count these external events and if an overflow occurs the device will be woken up from its Power-down condition. To prevent such a wake-up from occurring, the timer interrupt request flag should first be set high before issuing the HALT instruction to enter the Power Down Mode.

Timer Program Example

This program example shows how the Timer/Event Counter registers are setup, along with how the interrupts are enabled and managed. Note how the Timer/Event Counter is turned on, by setting bit 4 of the TMRC as an independent instruction. The Timer/Event Counter can be turned off in a similar way by clearing the same bit. This example program sets the Timer/Event Counter to be in the timer mode, which uses the internal system clock as the clock source.

```

org 04h          ; external interrupt vector
reti
org 08h          ; Timer/Event Counter interrupt vector
jmp tmrint0     ; jump here when Timer/Event Counter overflows
:
org 20h          ; main program
; internal Timer/Event Counter interrupt routine
tmrint0:
:
; Timer/Event Counter main program placed here
:
reti
:
:
begin:
; setup Timer registers
mov a, 09bh     ; setup Timer preload value
mov tmr, a
mov a, 081h     ; setup Timer control register
mov tmrc, a     ; timer mode and prescaler set to /4
; setup interrupt register
mov a, 005h     ; enable Master and Timer/Event Counter interrupt
mov intc0, a
set tmrc.4     ; start Timer/Event Counter - note mode bits must be previously setup

```

Pulse Width Modulator

The device contains two Pulse Width Modulation, PWM, outputs, known as PWM0 and PWM1. Useful for such applications such as motor speed control, the PWM function provides an output with a fixed frequency but with a duty cycle that can be varied by setting particular values into the corresponding PWM registers.

Channels	PWM Mode	Output Pins	Register Name
2	6+2 or 7+1	PA4 PA5	PWM0 PWM1

PWM Overview

The PWM outputs are selected via configuration options. Two registers, located in the Data Memory are assigned to the Pulse Width Modulator and are known as PWM0 and PWM1. It is in these registers that the 8-bit value, which represents the overall duty cycle of one modulation cycle of the output waveform, should be placed. To increase the PWM modulation frequency, each modulation cycle is modulated into two or four individual modulation sub-sections, known as the 7+1 mode or the 6+2 mode respectively. The device can choose which mode to use by selecting the appropriate configuration option. Note that it is only necessary to write the required modulation value into the corresponding

PWM0 or PWM1 register as the subdivision of the waveform into its sub-modulation cycles is implemented automatically within the microcontroller hardware. The PWM clock source is the system clock f_{SYS} .

This method of dividing the original modulation cycle into a further 2 or 4 sub-cycles enables the generation of higher PWM frequencies, which allow a wider range of applications to be served. As long as the periods of the generated PWM pulses are less than the time constants of the load, the PWM output will be suitable as such long time constant loads will average out the pulses of the PWM output. The difference between what is known as the PWM cycle frequency and the PWM modulation frequency should be understood. As the PWM clock is the system clock, f_{SYS} , and as the PWM value is 8-bits wide, the overall PWM cycle frequency is $f_{SYS}/256$. However, when in the 7+1 mode of operation, the PWM modulation frequency will be $f_{SYS}/128$, while the PWM modulation frequency for the 6+2 mode of operation will be $f_{SYS}/64$.

6+2 PWM Mode

Each full PWM cycle, as it is controlled by an 8-bit register, has 256 clock periods. However, in the 6+2 PWM Mode, each PWM cycle is subdivided into four individual sub-cycles known as modulation cycle 0~modulation cycle 3, denoted as "i" in the table. Each one of these

four sub-cycles contains 64 clock cycles. In this mode, a modulation frequency increase by a factor of four is achieved. The 8-bit PWM register value, which represents the overall duty cycle of the PWM waveform, is divided into two groups. The first group which consists of bit2~bit7 is denoted here as the DC value. The second group which consists of bit0~bit1 is known as the AC value. In the 6+2 PWM mode, the duty cycle value of each of the four modulation sub-cycles is shown in the following table.

Parameter	AC (0~3)	DC (Duty Cycle)
Modulation cycle i (i=0~3)	i < AC	$\frac{DC+1}{64}$
	i ≥ AC	$\frac{DC}{64}$

6+2 Mode Modulation Cycle Values

The following diagram illustrates the waveforms associated with the 6+2 mode of PWM operation. It is important to note how the single PWM cycle is subdivided into 4 individual modulation cycles, numbered from 0~3 and how the AC value is related to the PWM value.

7+1 PWM Mode

Each full PWM cycle, as it is controlled by an 8-bit register, has 256 clock periods. However, in the 7+1 PWM mode, each PWM cycle is subdivided into two individual sub-cycles known as modulation cycle 0 ~ modulation cycle 1, denoted as "i" in the table. Each one of these two sub-cycles contains 128 clock cycles. In this mode, a modulation frequency increase of two is achieved. The 8-bit PWM register value, which represents the overall

duty cycle of the PWM waveform, is divided into two groups. The first group which consists of bit1~bit7 is denoted here as the DC value. The second group which consists of bit0 is known as the AC value. In the 7+1 PWM mode, the duty cycle value of each of the two modulation sub-cycles is shown in the following table.

Parameter	AC (0~1)	DC (Duty Cycle)
Modulation cycle i (i=0~1)	i < AC	$\frac{DC+1}{128}$
	i ≥ AC	$\frac{DC}{128}$

7+1 Mode Modulation Cycle Values

The following diagram illustrates the waveforms associated with the 7+1 mode of PWM operation. It is important to note how the single PWM cycle is subdivided into 2 individual modulation cycles, numbered 0 and 1 and how the AC value is related to the PWM value.

PWM Output Control

PWM Modulation Frequency	PWM Cycle Frequency	PWM Cycle Duty
$f_{sys}/64$	$f_{sys}/256$	(PWM register value)/256

The PWM0 output is shared with pin PA4, the PWM1 output is shared with PA5. To operate as a PWM output and not as I/O pins, the correct PWM configuration option must be selected. A "0" must also be written to the corresponding bit in the I/O port control register, PAC.4 or PAC.5, to ensure that the corresponding PWM0 or

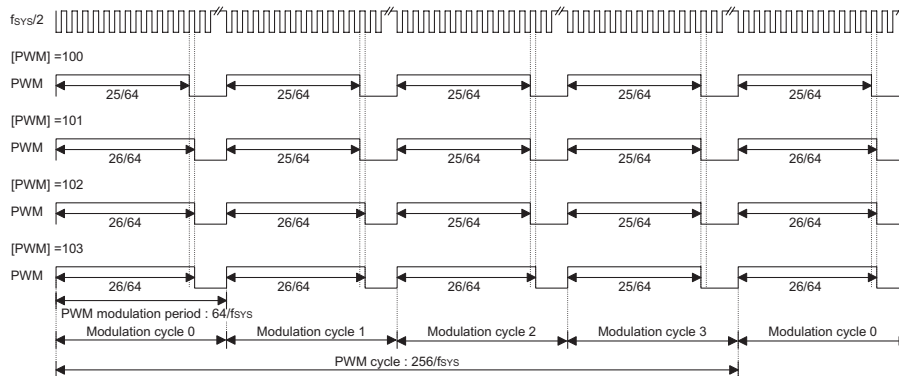

6+2 PWM Mode

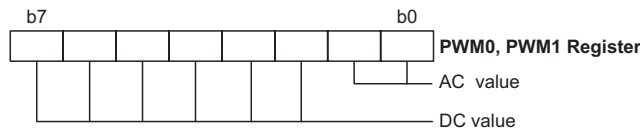

6+2 Pulse Width Modulation Mode Registers

PWM1 output pin is setup as an output. After these two initial steps have been carried out, and of course after the required PWM value has been written into the PWM0 or PWM1 register, writing a "1" to the corresponding PA.4 or PA.5 bit in the PA output data register will enable the PWM data to appear on the pin. Writing a "0" to the bit will disable the PWM output function and force the output low. In this way, the Port A data output register bits, PA.4 and PA.5, can be used as an on/off control for the PWM function. Note that if the configuration options have selected the PWM function, but a "1" has been written to its corresponding bit in the PAC con-

trol register to configure the pin as an input, then the pin can still function as a normal input line, with pull-high resistor options.

PWM Programming Example

The following sample program shows how the PWM outputs are setup and controlled. Before use the corresponding PWM output configuration options must first be selected.

```

mov a, 64h           ; setup PWM0 value of 100 decimal which is 64H
mov pwm0, a
clr pac.4           ; setup pin PA4 as an output
set pa.4           ; pa.4=1; enable the PWM output
: :
: :
clr pa.4           ; disable the PWM output - PA4 will remain low
    
```

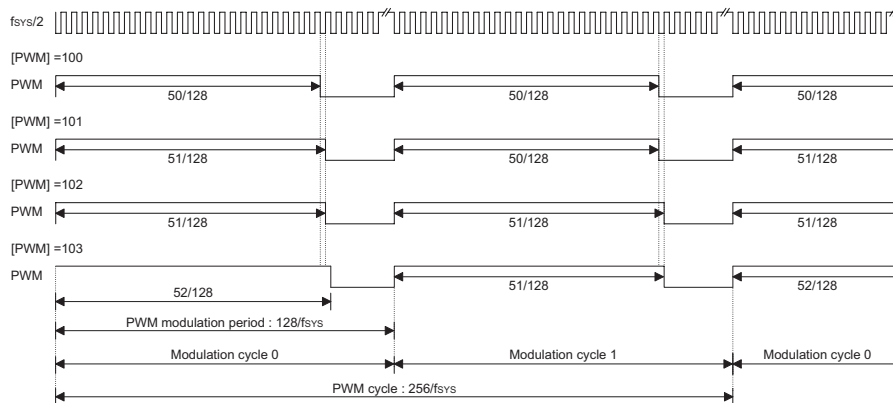

7+1 PWM Mode

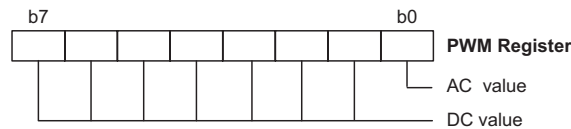

7+1 Pulse Width Modulation Mode Register

Analog to Digital Converter

The need to interface to real world analog signals is a common requirement for many electronic systems. However, to properly process these signals by a microcontroller, they must first be converted into digital signals by A/D converters. By integrating the A/D conversion electronic circuitry into the microcontroller, the need for external components is reduced significantly with the corresponding follow-on benefits of lower costs and reduced component space requirements.

A/D Overview

The device contains a 6-channel analog to digital converter which can directly interface to external analog signals, such as that from sensors or other control signals and convert these signals directly into a 12-bit digital value.

Input Channels	Conversion Bits	Input Pins
6	12	PB0~PB5

The accompanying diagram shows the overall internal structure of the A/D converter, together with its associated registers.

A/D Converter Data Registers – ADRL, ADRH

As the device contains a 12-bit A/D converter, it requires two data registers to store its conversion value, a high byte register, known as ADRH, and a low byte register, known as ADRL. After the conversion process takes place, these registers can be directly read by the microcontroller to obtain the digitised conversion value. Only the high byte register, ADRH, utilises its full 8-bit contents. The low byte register utilises only 4 bits of its 8-bit contents as it contains only the lowest bit of the 12-bit converted value.

In the following tables, D0~D11 are the A/D conversion data result bits.

Register	Bit 7	Bit 6	Bit 5	Bit 4	Bit 3	Bit 2	Bit 1	Bit 0
ADRL	D3	D2	D1	D0	—	—	—	—
ADRH	D11	D10	D9	D8	D7	D6	D5	D4

A/D Data Registers

A/D Converter Control Register – ADCR

To control the function and operation of the A/D converter, a control register known as ADCR is provided. This 8-bit register defines functions such as the selection of which analog channel is connected to the internal A/D converter, which pins are used as analog inputs and which are used as normal I/Os as well as controlling the start function and monitoring the A/D converter end of conversion status.

One section of this register contains the bits ACS2~ACS0 which define the channel number. As each of the devices contains only one actual analog to digital converter circuit, each of the individual 8 analog inputs must be routed to the converter. It is the function of the ACS2~ACS0 bits in the ADCR register to determine which analog channel is actually connected to the internal A/D converter.

The ADCR control register also contains the PCR2~PCR0 bits which determine which pins on Port B are used as analog inputs for the A/D converter and which pins are to be used as normal I/O pins. If the 3-bit address on PCR2~PCR0 has a value of "110" or "111", then all six pins, namely AN0~AN5 will all be set as analog inputs. Note that if the PCR2~PCR0 bits are all set to zero, then all the Port B pins will be setup as normal I/Os and the internal A/D converter circuitry will be powered off to reduce the power consumption.

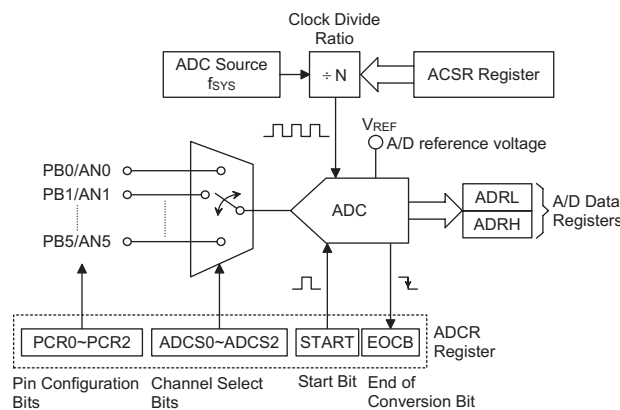

A/D Converter Structure

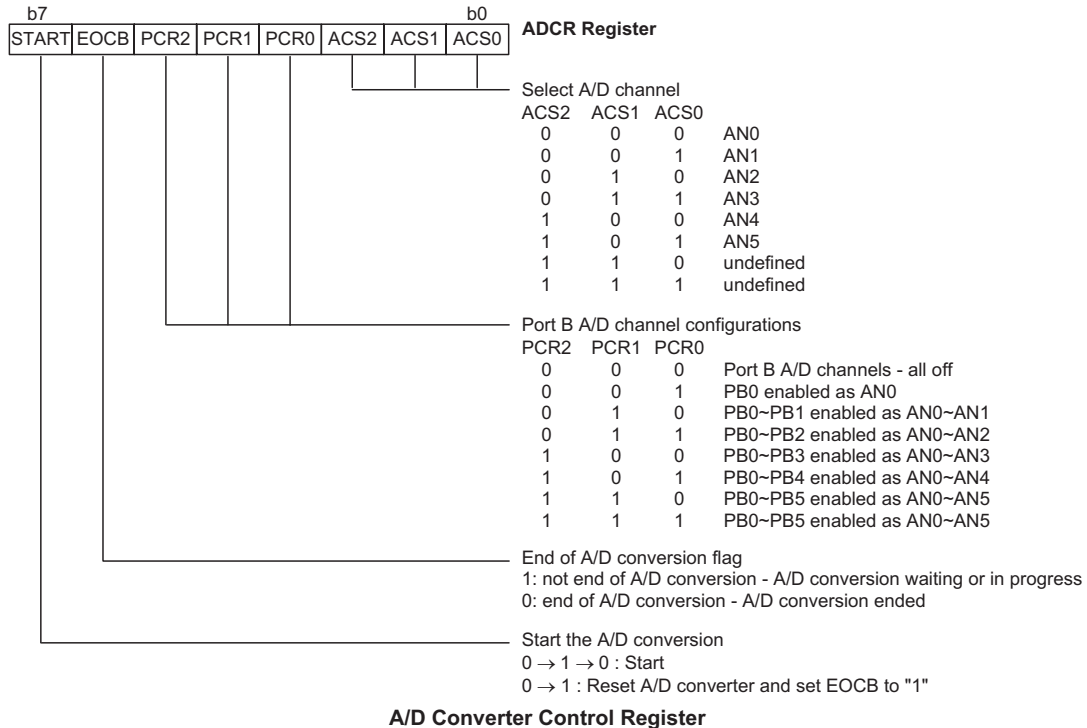

The START bit in the ADCR register is used to start and reset the A/D converter. When the microcontroller sets this bit from low to high and then low again, an analog to digital conversion cycle will be initiated. When the START bit is brought from low to high but not low again, the EOCB bit in the ADCR register will be set to a "1" and the analog to digital converter will be reset. It is the START bit that is used to control the overall on/off operation of the internal analog to digital converter.

The EOCB bit in the ADCR register is used to indicate when the analog to digital conversion process is complete. This bit will be automatically set to "0" by the microcontroller after a conversion cycle has ended. In addition, the corresponding A/D interrupt request flag will be set in the interrupt control register, and if the interrupts are enabled, an appropriate internal interrupt signal will be generated. This A/D internal interrupt signal will direct the program flow to the associated A/D internal interrupt address for processing. If the A/D internal interrupt is disabled, the microcontroller can be used to poll the EOCB bit in the ADCR register to check whether it has been cleared as an alternative method of detecting the end of an A/D conversion cycle.

A/D Converter Power Control

As an integrated circuit function within the device, the A/D converter will naturally consume a limited amount of power. However to provide users with a means of on/off control to reduce power consumption, two methods are

provided. One means of turning off the A/D converter circuitry is to ensure that the PCR0~PCR2 bits in the ADCR register are cleared to zero. Another method is to use the ADONB bit in the ACSR register, which if set high will also turn off the A/D internal circuitry. Both power off methods are independent and have overriding control over the other.

PCR Bits	ADONB Bit	A/D Circuits
0	X	Off
> 0	0	On
> 0	1	Off

A/D Power Control

It should be noted that the power supply to the A/D converter is supplied via the VDD pin. However the lowest operating voltage of the analog circuitry is higher than that of the digital circuitry and therefore the analog circuits will fail to operate at the lower end of the VDD specification. The DC Characteristics therefore specify a separate operating voltage specification for the analog circuitry.

A/D Converter Clock Source Register – ACSR

The clock source for the A/D converter, which originates from the system clock f_{SYS} , is first divided by a division ratio, the value of which is determined by the ADCS1 and ADCS0 bits in the ACSR register.

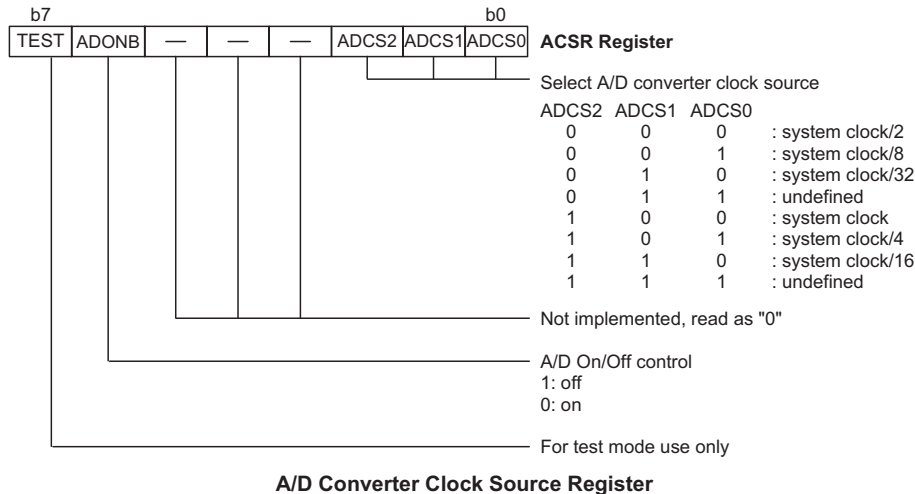

A/D Converter Clock Source Register

f _{sys}	A/D Clock Period (t _{AD})			
	ADCS2, ADCS1, ADCS0=000 (f _{sys} /2)	ADCS2, ADCS1, ADCS0=001 (f _{sys} /8)	ADCS2, ADCS1, ADCS0=010 (f _{sys} /32)	ADCS2, ADCS1, ADCS0=011
1MHz	2μs	8μs	32μs	Undefined
2MHz	1μs	4μs	16μs	Undefined
4MHz	500ns*	2μs	8μs	Undefined
8MHz	250ns*	1μs	4μs	Undefined

A/D Clock Period Examples

Although the A/D clock source is determined by the system clock f_{sys}, and by bits ADCS1 and ADCS0, there are some limitations on the maximum A/D clock source speed that can be selected. As the minimum value of permissible A/D clock period, t_{AD}, is 0.5μs, care must be taken for system clock speeds in excess of 4MHz. For system clock speeds in excess of 4MHz, the ADCS1 and ADCS0 bits should not be set to "00". Doing so will give A/D clock periods that are less than the minimum A/D clock period which may result in inaccurate A/D conversion values. Refer to the accompanying table for examples, where values marked with an asterisk * show where, depending upon the device, special care must be taken, as the values may be less than the specified minimum A/D Clock Period.

A/D Input Pins

All of the A/D analog input pins are pin-shared with the I/O pins on Port B. Bits PCR2~PCR0 in the ADCR register, not configuration options, determine whether the input pins are setup as normal Port B input/output pins or whether they are setup as analog inputs. In this way, pins can be changed under program control to change their function from normal I/O operation to analog inputs and vice versa. Pull-high resistors, which are setup through configuration options, apply to the input pins only when they are used as normal I/O pins, if setup as A/D inputs

the pull-high resistors will be automatically disconnected. Note that it is not necessary to first setup the A/D pin as an input in the PBC port control register to enable the A/D input as when the PCR2~PCR0 bits enable an A/D input, the status of the port control register will be overridden. The A/D reference voltage is supplied on an individual VREF pin and can be connected to an external reference voltage source. Appropriate measures should be taken to ensure that the VREF voltage does not exceed the VDD voltage level and that it remains as stable and noise free as possible.

Initialising the A/D Converter

The internal A/D converter must be in a special way. Each time the Port B A/D channel selection bits are modified by the program, the A/D converter must be re-initialised. If the A/D converter is not initialised after the channel selection bits are changed, the EOCB flag may have an undefined value, which may produce a false end of conversion signal. To initialise the A/D converter after the channel selection bits have changed, then, within a time frame of one to ten instruction cycles, the START bit in the ADCR register must first be set high and then immediately cleared to zero. This will ensure that the EOCB flag is correctly set to a high condition.

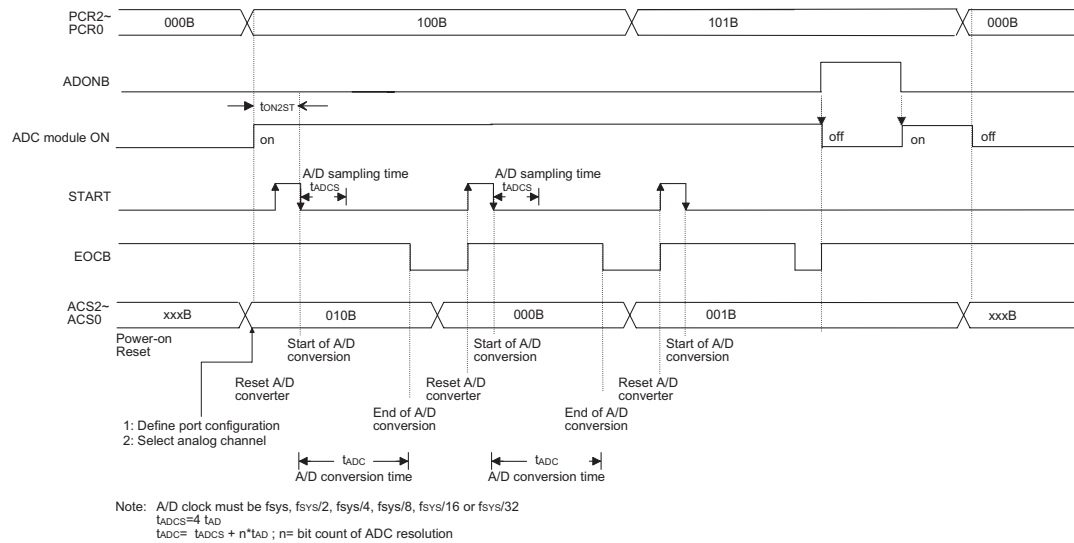

A/D Conversion Timing

Summary of A/D Conversion Steps

The following summarises the individual steps that should be executed in order to implement an A/D conversion process.

- Step 1
Select the required A/D conversion clock by correctly programming bits ADCS1 and ADCS0 in the ACSR register.
- Step 2
Enable the A/D by clearing the ADONB bit in the ACSR register.
- Step 3
Select which channel is to be connected to the internal A/D converter by correctly programming the ACS2~ACS0 bits which are also contained in the ADCR register.
- Step 4
Select which pins on Port B are to be used as A/D inputs and configure them as A/D input pins by correctly programming the PCR0~PCR2 bits in the ADCR register. Note that this step can be combined with Step 2 into a single ADCR register programming operation.
- Step 5
If the interrupts are to be used, the interrupt control registers must be correctly configured to ensure the A/D converter interrupt function is active. The master interrupt control bit, EMI, in the INTC interrupt control register must be set to "1" and the A/D converter interrupt bit, EADI, in the INTC register must also be set to "1".
- Step 6
The analog to digital conversion process can now be initialised by setting the START bit in the ADCR register from "0" to "1" and then to "0" again. Note that this bit should have been originally set to "0".
- Step 7
To check when the analog to digital conversion process is complete, the EOCB bit in the ADCR register

can be polled. The conversion process is complete when this bit goes low. When this occurs the A/D data registers ADRL and ADRH can be read to obtain the conversion value. As an alternative method, if the interrupts are enabled and the stack is not full, the program can wait for an A/D interrupt to occur.

Note: When checking for the end of the conversion process, if the method of polling the EOCB bit in the ADCR register is used, the interrupt enable step above can be omitted.

The accompanying timing diagram shows graphically the various stages involved in an analog to digital conversion process and its associated timing.

The setting up and operation of the A/D converter function is fully under the control of the application program as there are no configuration options associated with the A/D converter. After an A/D conversion process has been initiated by the application program, the microcontroller internal hardware will begin to carry out the conversion, during which time the program can continue with other functions. The time taken for the A/D conversion is $16t_{AD}$ where t_{AD} is equal to the A/D clock period.

Programming Considerations

When programming, special attention must be given to the A/D channel selection bits in the ADCR register. If these bits are all cleared to zero no external pins will be selected for use as A/D input pins allowing the pins to be used as normal I/O pins. When this happens the power supplied to the internal A/D circuitry will be turned off resulting in a reduction of supply current. This ability to reduce power by turning off the internal A/D function by clearing the A/D channel selection bits may be an important consideration in battery powered applications. The A/D can also be turned off by using the ADONB bit in the ACSR register.

Another important programming consideration is that when the A/D channel selection bits change value, the A/D converter must be . This is achieved by pulsing the START bit in the ADCR register immediately after the channel selection bits have changed state. The exception to this is where the channel selection bits are all cleared, in which case the A/D converter is not required to be re-initialised.

A/D Programming Example

The following two programming examples illustrate how to setup and implement an A/D conversion. In the first example, the method of polling the EOCB bit in the ADCR register is used to detect when the conversion cycle is complete, whereas in the second example, the A/D interrupt is used to determine when the conversion is complete.

Example: using an EOCB polling method to detect the end of conversion

```

clr    EADI                ; disable ADC interrupt
mov    a,00000001B
mov    ACSR,a              ; setup the ACSR register to select fSYS/8 as
                           ; the A/D clock
mov    a,00100000B        ; setup ADCR register to configure Port PB0~PB3
                           ; as A/D inputs
mov    ADCR,a             ; and select AN0 to be connected to the A/D
                           ; converter
:
:                          ; As the Port B channel bits have changed the
                           ; following START
                           ; signal (0-1-0) must be issued within 10
                           ; instruction cycles
:
Start_conversion:
clr    START
set    START              ; reset A/D
clr    START              ; start A/D
Polling_EOC:
sz     EOCB               ; poll the ADCR register EOCB bit to detect end
                           ; of A/D conversion
jmp    polling_EOC        ; continue polling
mov    a,ADRL             ; read low byte conversion result value
mov    adr1_buffer,a      ; save result to user defined register
mov    a,ADRH             ; read high byte conversion result value
mov    adrh_buffer,a      ; save result to user defined register
:
jmp    start_conversion    ; start next A/D conversion

```

Example: using the interrupt method to detect the end of conversion

```

clr    EADI                ; disable ADC interrupt
mov    a,00000001B
mov    ACSR,a              ; setup the ACSR register to select fSYS/8 as
                           ; the A/D clock
mov    a,00100000B        ; setup ADCR register to configure Port PB0~PB3
                           ; as A/D inputs
mov    ADCR,a             ; and select AN0 to be connected to the A/D
:
:                          ; As the Port B channel bits have changed the
                           ; following START signal(0-1-0) must be issued
                           ; within 10 instruction cycles
:
Start_conversion:
clr    START
set    START              ; reset A/D
clr    START              ; start A/D
clr    ADF                ; clear ADC interrupt request flag
set    EADI               ; enable ADC interrupt
set    EMI                ; enable global interrupt
:
:
:

```

```

; ADC interrupt service routine
ADC_ISR:
    mov     acc_stack,a           ; save ACC to user defined memory
    mov     a,STATUS
    mov     status_stack,a       ; save STATUS to user defined memory
    :
    :
    mov     a,ADRL                ; read low byte conversion result value
    mov     adrl_buffer,a         ; save result to user defined register
    mov     a,ADRH                ; read high byte conversion result value
    mov     adrh_buffer,a         ; save result to user defined register
    :
    :
EXIT_INT_ISR:
    mov     a,status_stack
    mov     STATUS,a             ; restore STATUS from user defined memory
    mov     a,acc_stack           ; restore ACC from user defined memory
    reti
    
```

A/D Transfer Function

As the device contain a 12-bit A/D converter, its full-scale converted digitised value is equal to FFFH. Since the full-scale analog input value is equal to the V_{DD} voltage, this gives a single bit analog input value of V_{DD}/4096. The diagram show the ideal transfer function between the analog input value and the digitised output value for the A/D converter.

Note that to reduce the quantisation error, a 0.5 LSB offset is added to the A/D Converter input. Except for the digitised zero value, the subsequent digitised values will change at a point 0.5 LSB below where they would change without the offset, and the last full scale digitised value will change at a point 1.5 LSB below the V_{DD} level.

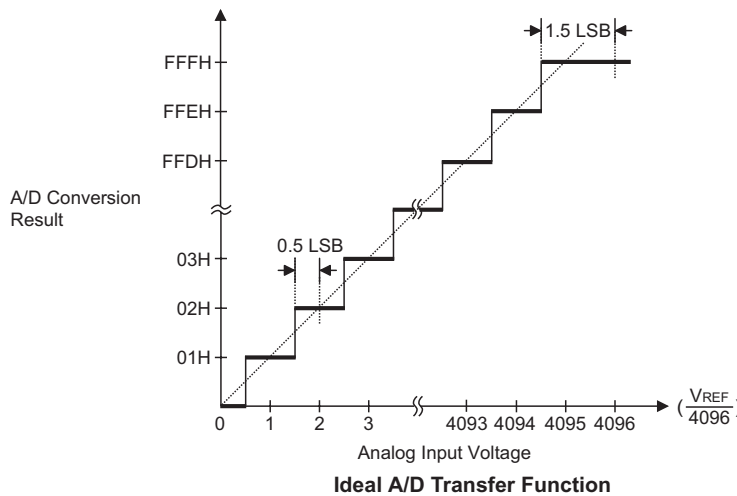

Operation Mode

The device can operate in three different modes which are known as Normal, Slow and Power Down. To support these different modes two system clocks are required, an RC or Crystal external system oscillator connected to the OSC1 and OSC2 pins and a 32768 external Crystal oscillator connected to the OSC3 and OSC4 pins. Both system clocks must be connected for correct operation.

Mode Selection

The choice of which system clock is used is made using the MODS bit in the MODE register and can be either an RC/XTAL oscillator or a 32768Hz RTC. Selecting the slower 32768Hz oscillator by setting the MODS bit high

will naturally cause the microcontroller to consume less power; this is known as the Slow Mode. In this mode the RC or Crystal oscillator will be turned off. Selecting the higher frequency RC or Crystal oscillator by setting the MODS bit to zero will place the microcontroller in the Normal Mode. The other mode, known as the Power-down Mode can only be entered when a HALT instruction is executed. Note that in all modes the 32768Hz oscillator continues to run.

If the 32768Hz oscillator is chosen as the system clock, then the WDT clock source configuration option must also select the 32768Hz oscillator as its clock source, otherwise unpredictable system operation may occur.

Mode	System Clock	HALT Instruction	MODS	RC/XTAL Oscillator	32768Hz
Normal	RC/XTAL oscillator	Not Executed	0	On	On
Slow	32768Hz	Not Executed	1	Off	On
Power Down	HALT	Executed	x	Off	On

Operation Mode

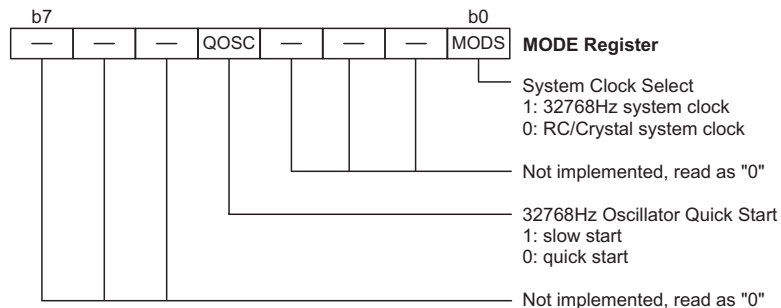

Operation Mode Register — MODE

Interrupts

Interrupts are an important part of any microcontroller system. When an external event or an internal function such as a Timer/Event Counter, Time Base or A/D converter requires microcontroller attention, their corresponding interrupt will enforce a temporary suspension of the main program allowing the microcontroller to direct attention to their respective needs. Each device in this series contains a single external interrupt and several internal interrupts functions. The external interrupt is controlled by the action of the external INT pin, while the internal interrupts are controlled by the Timer/Event Counter overflow, Time Base overflow interrupt and the A/D converter interrupt.

Interrupt Registers

Overall interrupt control, which means interrupt enabling and request flag setting, is controlled by the INTC0 and INTC1 registers, which are located in the Data Memory. By controlling the appropriate enable bits in this register each individual interrupt can be enabled or disabled. Also when an interrupt occurs, the corresponding request flag will be set by the microcontroller. The global enable flag if cleared to zero will disable all interrupts.

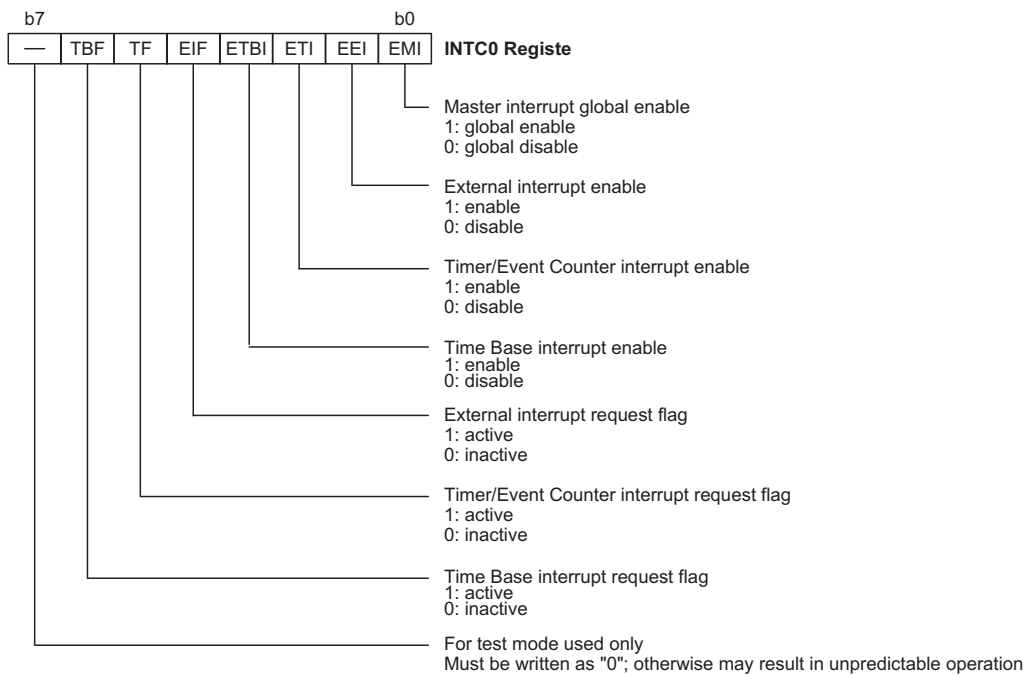

Interrupt Control 0 Registers

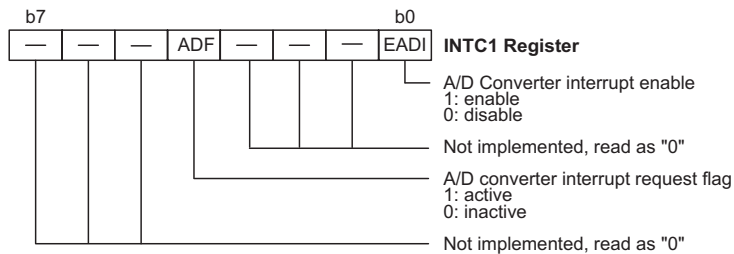

Interrupt Control 1 Registers

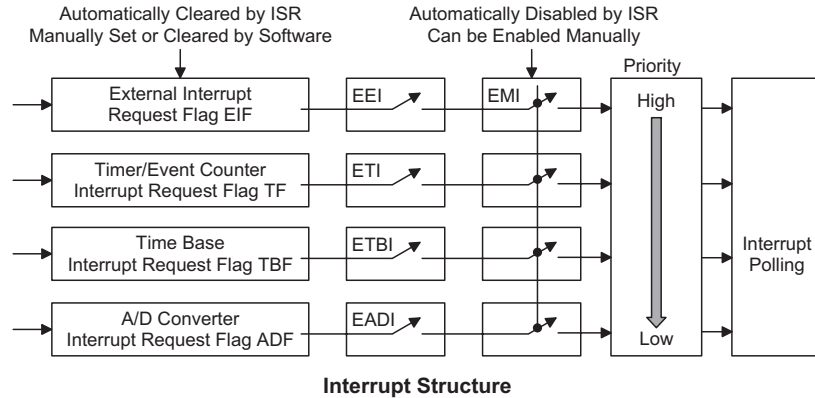

Interrupt Operation

A Timer/Event Counter overflow, a Time Base overflow, an end of A/D conversion or the external interrupt line being pulled low will all generate an interrupt request by setting their corresponding request flag, if their appropriate interrupt enable bit is set. When this happens, the Program Counter, which stores the address of the next instruction to be executed, will be transferred onto the stack. The Program Counter will then be loaded with a new address which will be the value of the corresponding interrupt vector. The microcontroller will then fetch its next instruction from this interrupt vector. The instruction at this vector will usually be a JMP statement which will jump to another section of program which is known as the interrupt service routine. Here is located the code to control the appropriate interrupt. The interrupt service routine must be terminated with a RETI statement, which retrieves the original Program Counter address from the stack and allows the microcontroller to continue with normal execution at the point where the interrupt occurred.

The various interrupt enable bits, together with their associated request flags, are shown in the following diagram with their order of priority.

Once an interrupt subroutine is serviced, all the other interrupts will be blocked, as the EMI bit will be cleared automatically. This will prevent any further interrupt nesting from occurring. However, if other interrupt requests occur during this interval, although the interrupt will not be immediately serviced, the request flag will still be recorded. If an interrupt requires immediate servicing while the program is already in another interrupt service routine, the EMI bit should be set after entering the routine, to allow interrupt nesting. If the stack is full, the interrupt request will not be acknowledged, even if the related interrupt is enabled, until the Stack Pointer is decremented. If immediate service is desired, the stack must be prevented from becoming full.

Interrupt Priority

Interrupts, occurring in the interval between the rising edges of two consecutive T2 pulses, will be serviced on

the latter of the two T2 pulses, if the corresponding interrupts are enabled. In case of simultaneous requests, the following table shows the priority that is applied. These can be masked by resetting the EMI bit.

Interrupt Source	Vector	Priority
External Interrupt	04H	1
Timer/Event Counter Overflow	08H	2
Time Base Overflow	0CH	3
A/D Converter Conversion End	10H	4

Interrupt Priority

In cases where both external and internal interrupts are enabled and where an external and internal interrupt occurs simultaneously, the external interrupt will always have priority and will therefore be serviced first. Suitable masking of the individual interrupts using the INTC0 and INTC1 registers can prevent simultaneous occurrences.

External Interrupt

For an external interrupt to occur, the global interrupt enable bit, EMI, and external interrupt enable bit, EEI, must first be set. An actual external interrupt will take place when the external interrupt request flag, EIF in INTC0. As the external interrupt is a dual edge triggered type, the EIF flag will be set when either a high to low or low to high transition appears on the INT line. The external interrupt pin is pin-shared with the output pin PD0 and can only be configured as an external interrupt pin if the corresponding external interrupt enable bit in the INTC0 register has been set and the PD0 output is disabled by setting the LCDEN bit in the LCDC register to zero and the PD0 bit set high. If the external interrupt enable bit is not set then the pin can be used as a PD0 CMOS output pin. When the interrupt is enabled, the stack is not full and a high to low transition appears on the external interrupt pin, a subroutine call to the external interrupt vector at location 04H, will take place. When the interrupt is serviced, the external interrupt request flag, EIF; bit 4 of INTC0 will be automatically reset and the EMI bit will be automatically cleared to disable other interrupts.

Timer/Event Counter Interrupt

For a Timer/Event Counter interrupt to occur, the global interrupt enable bit, EMI, and the corresponding timer interrupt enable bit, ETI in the INTC0 register must first be set. An actual Timer/Event Counter interrupt will take place when the Timer/Event Counter interrupt request flag, TF in INTC0, is set, a situation that will occur when the relevant Timer/Event Counter overflows. When the interrupt is enabled, the stack is not full and a Timer/Event Counter overflow occurs, a subroutine call to the timer interrupt vector at location 08H will take place for Timer/Event Counter. When the interrupt is serviced, the timer interrupt request flag, TF, will be automatically reset and the EMI bit will be automatically cleared to disable other interrupts.

Time Base Interrupt

For a Time Base interrupt to occur, the global interrupt enable bit, EMI, in the INTC0 register, and the Time Base interrupt enable bit, ETBI, in the INTC0 register must first be set. An actual Time Base interrupt will take place when the Time Base request flag, TBF in INTC0 is set, a situation that will occur when the Time Base overflows. When the interrupt is enabled, the stack is not full, and a Time Base overflow occurs, a subroutine call to the Time Base vector location at 0CH will take place. When the interrupt is serviced, the Time Base interrupt request flag, TBF, will be automatically reset and the EMI bit will be automatically cleared to disable other interrupts.

A/D Interrupt

For an A/D interrupt to occur, the global interrupt enable bit, EMI, and the corresponding interrupt enable bit, EADI, must be first set. An actual A/D interrupt will take

place when the A/D converter request flag, ADF in the INTC1 register is set, a situation that will occur when an A/D conversion process has completed. When the interrupt is enabled, the stack is not full and an A/D conversion process finishes execution, a subroutine call to the A/D interrupt vector at location 10H, will take place. When the interrupt is serviced, the A/D interrupt request flag, ADF, will be automatically reset and the EMI bit will be automatically cleared to disable other interrupts.

Programming Considerations

By disabling the interrupt enable bits, a requested interrupt can be prevented from being serviced, however, once an interrupt request flag is set, it will remain in this condition in the INTC0 or INTC1 register until the corresponding interrupt is serviced or until the request flag is cleared by a software instruction.

It is recommended that programs do not use the "CALL subroutine" instruction within the interrupt subroutine. Interrupts often occur in an unpredictable manner or need to be serviced immediately in some applications. If only one stack is left and the interrupt is not well controlled, the original control sequence will be damaged once a "CALL subroutine" is executed in the interrupt subroutine.

All of these interrupts have the capability of waking up the processor when in the Power Down Mode.

Only the Program Counter is pushed onto the stack. If the contents of the register or status register are altered by the interrupt service program, which may corrupt the desired control sequence, then the contents should be saved in advance.

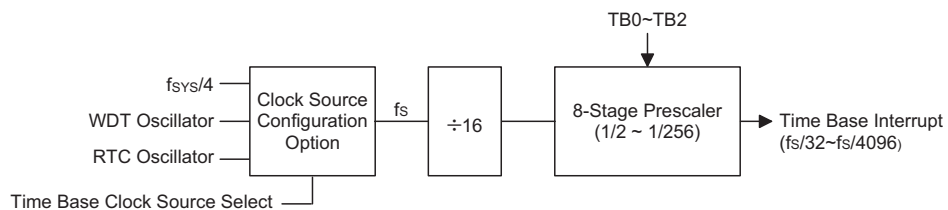

Time Base Interrupt

Reset and Initialisation

A reset function is a fundamental part of any microcontroller ensuring that the device can be set to some predetermined condition irrespective of outside parameters. The most important reset condition is after power is first applied to the microcontroller. In this case, internal circuitry will ensure that the microcontroller, after a short delay, will be in a well defined state and ready to execute the first program instruction. After this power-on reset, certain important internal registers will be set to defined states before the program commences. One of these registers is the Program Counter, which will be reset to zero forcing the microcontroller to begin program execution from the lowest Program Memory address.

In addition to the power-on reset, situations may arise where it is necessary to forcefully apply a reset condition when the is running. One example of this is where after power has been applied and the microcontroller is already running, the $\overline{\text{RES}}$ line is forcefully pulled low. In such a case, known as a normal operation reset, some of the microcontroller registers remain unchanged allowing the microcontroller to proceed with normal operation after the reset line is allowed to return high. Another type of reset is when the Watchdog Timer overflows and resets the microcontroller. All types of reset operations result in different register conditions being setup.

Another reset exists in the form of a Low Voltage Reset, LVR, where a full reset, similar to the $\overline{\text{RES}}$ reset is implemented in situations where the power supply voltage falls below a certain threshold.

Reset Functions

There are five ways in which a microcontroller reset can occur, through events occurring both internally and externally:

- Power-on Reset
The most fundamental and unavoidable reset is the one that occurs after power is first applied to the microcontroller. As well as ensuring that the Program Memory begins execution from the first memory address, a power-on reset also ensures that certain other registers are preset to known conditions. All the I/O port and port control registers will power up in a high condition ensuring that all pins will be first set to inputs. Although the microcontroller has an internal RC reset function, if the VDD power supply rise time is not fast enough or does not stabilise quickly at power-on, the internal reset function may be incapable of providing proper reset operation. For this reason it is recommended that an external RC network is connected to the $\overline{\text{RES}}$ pin, whose additional time delay will ensure that the $\overline{\text{RES}}$ pin remains low for an extended period to allow the power supply to stabilise. During this time delay, normal operation of the microcontroller will be

inhibited. After the $\overline{\text{RES}}$ line reaches a certain voltage value, the reset delay time t_{RSTD} is invoked to provide an extra delay time after which the microcontroller will begin normal operation. The abbreviation SST in the figures stands for System Start-up Timer.

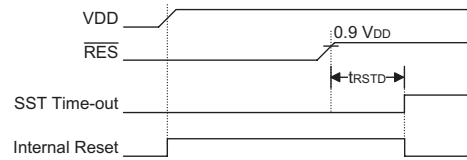

Power-On Reset Timing Chart

For most applications a resistor connected between VDD and the $\overline{\text{RES}}$ pin and a capacitor connected between VSS and the $\overline{\text{RES}}$ pin will provide a suitable external reset circuit. Any wiring connected to the $\overline{\text{RES}}$ pin should be kept as short as possible to minimise any stray noise interference.

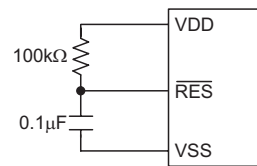

Basic Reset Circuit

For applications that operate within an environment where more noise is present the Enhanced Reset Circuit shown is recommended.

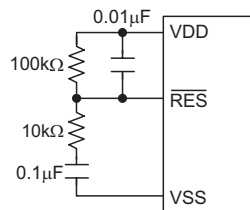

Enhanced Reset Circuit

More information regarding external reset circuits is located in Application Note HA0075E on the Holtek website.

- $\overline{\text{RES}}$ Pin Reset
This type of reset occurs when the microcontroller is already running and the $\overline{\text{RES}}$ pin is forcefully pulled low by external hardware such as an external switch. In this case as in the case of other reset, the Program Counter will reset to zero and program execution initiated from this point.

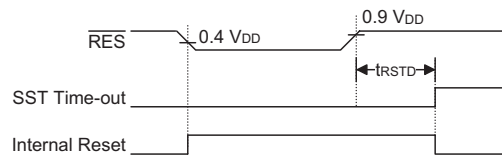

$\overline{\text{RES}}$ Reset Timing Chart

• Low Voltage Reset – LVR

The microcontroller contains a low voltage reset circuit in order to monitor the supply voltage of the device. The LVR function is selected via a configuration option. If the supply voltage of the device drops to within a range of $0.9V \sim V_{LVR}$ such as might occur when changing the battery, the LVR will automatically reset the device internally. For a valid LVR signal, a low supply voltage, i.e., a voltage in the range between $0.9V \sim V_{LVR}$ must exist for a time greater than that specified by t_{LVR} in the A.C. characteristics. If the low supply voltage state does not exceed this value, the LVR will ignore the low supply voltage and will not perform a reset function. The actual V_{LVR} value can be selected via configuration options.

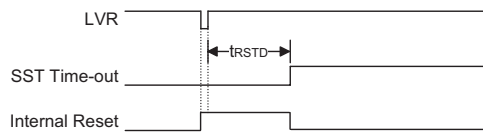

Low Voltage Reset Timing Chart

- Watchdog Time-out Reset during Normal Operation
The Watchdog time-out Reset during normal operation is the same as a hardware \overline{RES} pin reset except that the Watchdog time-out flag TO will be set to "1".

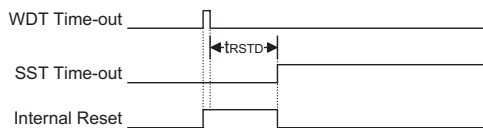

WDT Time-out Reset during Normal Operation Timing Chart

- Watchdog Time-out Reset during Power Down
The Watchdog time-out Reset during Power Down is a little different from other kinds of reset. Most of the conditions remain unchanged except that the Program Counter and the Stack Pointer will be cleared to "0" and the TO flag will be set to "1". Refer to the A.C. Characteristics for t_{SST} details.

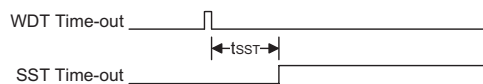

WDT Time-out Reset during Power Down Timing Chart

Reset Initial Conditions

The different types of reset described affect the reset flags in different ways. These flags, known as PDF and TO are located in the status register and are controlled by various microcontroller operations, such as the Power Down function or Watchdog Timer. The reset flags are shown in the table:

TO	PDF	RESET Conditions
0	0	\overline{RES} reset during power-on
u	u	\overline{RES} or LVR reset during normal operation
1	u	WDT time-out reset during normal operation
1	1	WDT time-out reset during Power Down

Note: "u" stands for unchanged

The following table indicates the way in which the various components of the microcontroller are affected after a power-on reset occurs.

Item	Condition After RESET
Program Counter	Reset to zero
Interrupts	All interrupts will be disabled
WDT	Clear after reset, WDT begins counting
Timer/Event Counter	Timer Counter will be turned off
Prescaler	The Timer Counter Prescaler will be cleared
Input/Output Ports	I/O ports will be setup as inputs
Stack Pointer	Stack Pointer will point to the top of the stack

The different kinds of resets all affect the internal registers of the microcontroller in different ways. To ensure reliable continuation of normal program execution after a reset occurs, it is important to know what condition the microcontroller is in after a particular reset occurs. The accompanying table describes how each type of reset affects each of the microcontroller internal registers.

Register	Reset (Power-on)	RES or LVR Reset	WDT Time-out (Normal Operation)	WDT Time-out (HALT)
MP0	x x x x x x x x	u u u u u u u u	u u u u u u u u	u u u u u u u u
MP1	x x x x x x x x	u u u u u u u u	u u u u u u u u	u u u u u u u u
ACC	x x x x x x x x	u u u u u u u u	u u u u u u u u	u u u u u u u u
PCL	0 0 0 0 0 0 0 0	0 0 0 0 0 0 0 0	0 0 0 0 0 0 0 0	0 0 0 0 0 0 0 0
TBLP	x x x x x x x x	u u u u u u u u	u u u u u u u u	u u u u u u u u
TBLH	- x x x x x x x	- u u u u u u u	- u u u u u u u	- u u u u u u u
STATUS	-- 0 0 x x x x	-- u u u u u u	-- 1 u u u u u	-- 1 1 u u u u
INTC0	- 0 0 0 0 0 0 0 0	- 0 0 0 0 0 0 0 0	- 0 0 0 0 0 0 0 0	- u u u u u u u u
TMR	x x x x x x x x	x x x x x x x x	x x x x x x x x	u u u u u u u u
TMRC	0 0 - 0 1 0 0 0 0	0 0 - 0 1 0 0 0 0	0 0 - 0 1 0 0 0 0	u u - u u u u u
PA	1 1 1 1 1 1 1 1	1 1 1 1 1 1 1 1	1 1 1 1 1 1 1 1	u u u u u u u u
PAC	1 1 1 1 1 1 1 1	1 1 1 1 1 1 1 1	1 1 1 1 1 1 1 1	u u u u u u u u
PB	1 1 1 1 1 1 1 1	1 1 1 1 1 1 1 1	1 1 1 1 1 1 1 1	u u u u u u u u
PBC	1 1 1 1 1 1 1 1	1 1 1 1 1 1 1 1	1 1 1 1 1 1 1 1	u u u u u u u u
PC	0 0 0 0 0 0 0 0	0 0 0 0 0 0 0 0	0 0 0 0 0 0 0 0	u u u u u u u u
PD	1 1 1 1 1 1 1 1	1 1 1 1 1 1 1 1	1 1 1 1 1 1 1 1	u u u u u u u u
PE	1 1 1 1 1 1 1 1	1 1 1 1 1 1 1 1	1 1 1 1 1 1 1 1	u u u u u u u u
PWM0	x x x x x x x x	x x x x x x x x	x x x x x x x x	u u u u u u u u
PWM1	x x x x x x x x	x x x x x x x x	x x x x x x x x	u u u u u u u u
INTC1	--- 0 --- 0	--- 0 --- 0	--- 0 --- 0	--- u --- u
LCDC	-- 0 0 0 0 0 0 0 0	-- 0 0 0 0 0 0 0 0	-- 0 0 0 0 0 0 0 0	-- u u u u u u
MODE	--- 0 --- 0	--- 0 --- 0	--- 0 --- 0	--- u --- u
ADRL	x x x x - - - -	x x x x - - - -	x x x x - - - -	u u u u - - - -
ADRH	x x x x x x x x	x x x x x x x x	x x x x x x x x	u u u u u u u u
ADCR	0 1 0 0 0 0 0 0	0 1 0 0 0 0 0 0	0 1 0 0 0 0 0 0	u u u u u u u u
ACSR	1 0 - - - 0 0 0	1 0 - - - 0 0 0	1 0 - - - 0 0 0	1 u - - - u u u

"u" stands for unchanged

"x" stands for unknown

"-" stands for unimplemented

Oscillator

Various oscillator options offer the user a wide range of functions according to their various application requirements. Three types of system clocks can be selected while various clock source options for the Watchdog Timer are provided for maximum flexibility.

The Three methods of generating the system clock are:

- External crystal/resonator oscillator
- External RC oscillator
- External 32768Hz oscillator

The choice of External crystal/resonator or RC system oscillator is made via a configuration option while the selection of the 32768Hz oscillator is made using the MODS bit in the MODE register. The 32768Hz Oscillator must always be connected along with a choice of either RC or crystal/resonator for correct operation.

More information regarding the oscillator is located in Application Note HA0075E on the Holtek website.

External Crystal/Resonator Oscillator

The simple connection of a crystal across OSC1 and OSC2 will create the necessary phase shift and feedback for oscillation, and will normally not require external capacitors. However, for some crystals and most resonator types, to ensure oscillation and accurate fre-

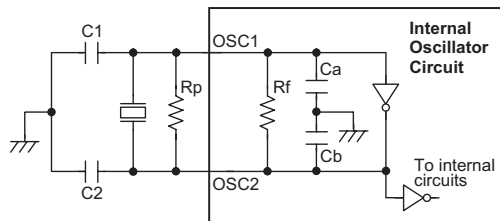

Note: 1. Rp is normally not required.
2. Although not shown OSC1/OSC2 pins have a parasitic capacitance of around 7pF.

External Crystal/Ceramic Oscillator

quency generation, it may be necessary to add two small value external capacitors, C1 and C2. The exact values of C1 and C2 should be selected in consultation with the crystal or resonator manufacturer's specification. The external parallel feedback resistor, Rp, is normally not required but in some cases may be needed to assist with oscillation start up.

Internal Ca, Cb, Rf Typical Values @ 5V, 25°C		
Ca	Cb	Rf
11pF~13pF	13pF~15pF	470kΩ

Oscillator Internal Component Values

Crystal Oscillator C1 and C2 Values			
Crystal Frequency	C1	C2	CL
12MHz	TBD	TBD	TBD
8MHz	TBD	TBD	TBD
4MHz	TBD	TBD	TBD
1MHz	TBD	TBD	TBD

Note: 1. C1 and C2 values are for guidance only.
2. CL is the crystal manufacturer specified load capacitor value.

Crystal Recommended Capacitor Values

Resonator C1 and C2 Values		
Resonator Frequency	C1	C2
3.58MHz	TBD	TBD
1MHz	TBD	TBD
455kHz	TBD	TBD

Note: C1 and C2 values are for guidance only.

Resonator Recommended Capacitor Values

External RC Oscillator

Using the external system RC oscillator requires that a resistor, with a value between 24kΩ and 1MΩ, is connected between OSC1 and VDD, and a capacitor is connected to ground. Although this is a cost effective oscillator configuration, the oscillation frequency can vary with VDD, temperature and process variations and is therefore not suitable for applications where timing is critical or where accurate oscillator frequencies are required. For the value of the external resistor R_{osc} refer to the Holtek website for typical RC Oscillator vs. Temperature and VDD characteristics graphics Here only the OSC1 pin is used, which is shared with I/O pin PA6, leaving pin PA5 free for use as a normal I/O pin. Note that it is the only microcontroller internal circuitry together with the external resistor, that determine the frequency of the oscillator. The external capacitor shown on the diagram does not influence the frequency of oscillation.

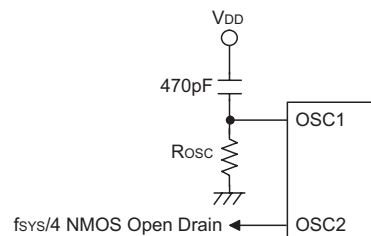

External RC Oscillator

External RTC Oscillator

When the microcontroller enters the Power Down Mode, the system clock is switched off to stop microcontroller activity and to conserve power. However, in many microcontroller applications it may be necessary to keep some internal functions such as timers operational even when the microcontroller is in the Power Down Mode. To do this, a 32768Hz oscillator, also known as the Real Time Clock or RTC oscillator, is provided. To implement

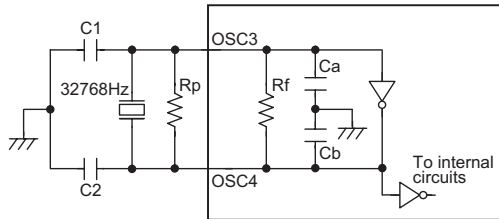

Note: 1. Rp is normally not required.
2. Although not shown OSC3/OSC4 pins have a parasitic capacitance of around 7pF.

Internal RC Oscillator + External RTC Oscillator

this clock, the OSC3 and OSC4 pins should be connected to a 32768Hz crystal. However, for some crystals, to ensure oscillation and accurate frequency generation, it may be necessary to add two small value external capacitors, C1 and C2. The exact values of C1 and C2 should be selected in consultation with the crystal or resonator manufacturer's specification. The external parallel feedback resistor, Rp, is normally not required but in some cases may be needed to assist with oscillation start up. The MODS bit in the MODE register is used to select whether the external 32768Hz oscillator or the External Crystal/External RC is used as the system oscillator. Using the slower 32768Hz oscillator as the system oscillator will of course use less power and is known as the Slow Mode.

Internal Ca, Cb, Rf Typical Values @ 5V, 25°C		
Ca	Cb	Rf
TBD	TBD	TBD

RTC Oscillator Internal Component Values

RTC Oscillator C1 and C2 Values			
Crystal Frequency	C1	C2	CL
32768Hz	TBD	TBD	TBD

Note: 1. C1 and C2 values are for guidance only.
2. CL is the crystal manufacturer specified load capacitor value.

32768 Hz Crystal Recommended Capacitor Values

When the system enters the Power Down Mode, the 32768Hz oscillator will keep running and if it is selected as the Timer and Watchdog Timer source clock, will also keep these functions operational.

During power up there is a time delay associated with the RTC oscillator, waiting for it to start up. The QOSC bit in the MODE register, is provided to give a quick start-up function and can be used to minimise this delay. During a power up condition, this bit will be cleared to 0 which will initiate the RTC oscillator quick start-up function. However, as there is additional power consumption associated with this quick start-up function, to reduce power consumption after start up takes place, it is recommended that the application program should set the QOSC bit high about 2 seconds after power on. It should be noted that, no matter what condition the QOSC bit is set to, the RTC oscillator will always function normally, only there is more power consumption associated with the quick start-up function.

Watchdog Timer Oscillator

The WDT oscillator is a fully self-contained free running on-chip RC oscillator with a typical period of 65µs at 5V requiring no external components. When the device enters the Power Down Mode, the system clock will stop running but the WDT oscillator continues to free-run and to keep the watchdog active. However, to preserve power in certain applications the WDT oscillator can be disabled via a configuration option.

Power Down Mode and Wake-up

Power Down Mode

All of the microcontrollers have the ability to enter a Power Down Mode. When the device enters this mode, the normal operating current, will be reduced to an extremely low standby current level. This occurs because when the device enters the Power Down Mode, the system oscillator is stopped which reduces the power consumption to extremely low levels, however, as the device maintains its present internal condition, it can be woken up at a later stage and continue running, without requiring a full reset. This feature is extremely important in application areas where the MCU must have its power supply constantly maintained to keep the device in a known condition but where the power supply capacity is limited such as in battery applications.

Entering the Power Down Mode

There is only one way for the device to enter the Power Down Mode and that is to execute the "HALT" instruction in the application program. When this instruction is executed, the following will occur:

- The system oscillator will stop running and the application program will stop at the "HALT" instruction.
- The Data Memory contents and registers will maintain their present condition.
- The WDT will be cleared and resume counting if the WDT clock source is selected to come from the WDT internal oscillator. The WDT will stop if its clock source originates from the system clock.
- The I/O ports will maintain their present condition.
- In the status register, the Power Down flag, PDF, will be set and the Watchdog time-out flag, TO, will be cleared.

Standby Current Considerations

As the main reason for entering the Power Down Mode is to keep the current consumption of the MCU to as low a value as possible, perhaps only in the order of several micro-amps, there are other considerations which must also be taken into account by the circuit designer if the power consumption is to be minimised. Special attention must be made to the I/O pins on the device. All high-impedance input pins must be connected to either a fixed high or low level as any floating input pins could create internal oscillations and result in increased current consumption. Care must also be taken with the loads, which are connected to I/O pins, which are setup as outputs. These should be placed in a condition in which minimum current is drawn or connected only to external circuits that do not draw current, such as other CMOS inputs. Also note that additional standby current will also be required if the configuration options have enabled the Watchdog Timer internal oscillator.

Wake-up

After the system enters the Power Down Mode, it can be woken up from one of various sources listed as follows:

- An external reset
- An external falling edge on Port A
- A system interrupt
- A WDT overflow

If the system is woken up by an external reset, the device will experience a full system reset, however, if the device is woken up by a WDT overflow, a Watchdog Timer reset will be initiated. Although both of these wake-up methods will initiate a reset operation, the actual source of the wake-up can be determined by examining the TO and PDF flags. The PDF flag is cleared by a system power-up or executing the clear Watchdog Timer instructions and is set when executing the "HALT" instruction. The TO flag is set if a WDT time-out occurs, and causes a wake-up that only resets the Program Counter and Stack Pointer, the other flags remain in their original status.

Each pin on Port A can be setup via an individual configuration option to permit a negative transition on the pin to wake-up the system. When a Port A pin wake-up occurs, the program will resume execution at the instruction following the "HALT" instruction.

If the system is woken up by an interrupt, then two possible situations may occur. The first is where the related interrupt is disabled or the interrupt is enabled but the stack is full, in which case the program will resume execution at the instruction following the "HALT" instruction. In this situation, the interrupt which woke-up the device will not be immediately serviced, but will rather be serviced later when the related interrupt is finally enabled or when a stack level becomes free. The other situation is where the related interrupt is enabled and the stack is not full, in which case the regular interrupt response takes place. If an interrupt request flag is set to "1" before entering the Power Down Mode, the wake-up function of the related interrupt will be disabled.

No matter what the source of the wake-up event is, once a wake-up situation occurs, a time period equal to 1024 system clock periods will be required before normal system operation resumes. However, if the wake-up has originated due to an interrupt, the actual interrupt subroutine execution will be delayed by an additional one or more cycles. If the wake-up results in the execution of the next instruction following the "HALT" instruction, this will be executed immediately after the 1024 system clock period delay has ended.

Watchdog Timer

The Watchdog Timer is provided to prevent program malfunctions or sequences from jumping to unknown locations, due to certain uncontrollable external events such as electrical noise. It operates by providing a device reset when the WDT counter overflows. The WDT clock is supplied by one of three sources selected by configuration option: its own self contained dedicated internal WDT oscillator, $f_{SYS}/4$ or the RTC oscillator. Note that if the WDT configuration option has been disabled, then any instruction relating to its operation will result in no operation.

In the device, all Watchdog Timer options, such as enable/disable, WDT clock source and clear instruction type all selected through configuration options. There are no internal registers associated with the WDT in the Cost-Effective A/D Type MCU series. One of the WDT clock sources is an internal oscillator which has an approximate period of $65\mu s$ at a supply voltage of 5V. However, it should be noted that this specified internal clock period can vary with V_{DD} , temperature and process variations. Watchdog Timer time-out value is of $2^{14}/f_S$ to $2^{21}/f_S$.

If the $f_{SYS}/4$ clock is used as the WDT clock source, it should be noted that when the system enters the Power Down Mode, then the instruction clock is stopped and the WDT will lose its protecting purposes. For systems that operate in noisy environments, using the internal WDT oscillator is strongly recommended.

Under normal program operation, a WDT time-out will initialise a device reset and set the status bit TO. However, if the system is in the Power Down Mode, when a WDT time-out occurs, the TO bit in the status register will be set and only the Program Counter and Stack Pointer will be reset. Three methods can be adopted to clear the contents of the WDT. The first is an external hardware reset, which means a low level on the \overline{RES} pin, the second is using the watchdog software instructions and the third is via a "HALT" instruction.

There are two methods of using software instructions to clear the Watchdog Timer, one of which must be chosen by configuration option. The first option is to use the single "CLR WDT" instruction while the second is to use the two commands "CLR WDT1" and "CLR WDT2". For the first option, a simple execution of "CLR WDT" will clear the WDT while for the second option, both "CLR WDT1" and "CLR WDT2" must both be executed to successfully clear the WDT. Note that for this second option, if "CLR WDT1" is used to clear the WDT, successive executions

of this instruction will have no effect, only the execution of a "CLR WDT2" instruction will clear the WDT. Similarly after the "CLR WDT2" instruction has been executed, only a successive "CLR WDT1" instruction can clear the Watchdog Timer.

Buzzer

Operating in a similar way to the Programmable Frequency Divider, the Buzzer function provides a means of producing a variable frequency output, suitable for applications such as Piezo-buzzer driving or other external circuits that require a precise frequency generator. The BZ and \overline{BZ} pins form a complimentary pair, and are pin-shared with I/O pins, PA0 and PA1. A configuration option is used to select from one of three buzzer options. The first option is for both pins PA0 and PA1 to be used as normal I/Os, the second option is for both pins to be configured as BZ and \overline{BZ} buzzer pins, the third option selects only the PA0 pin to be used as a BZ buzzer pin with the PA1 pin retaining its normal I/O pin function. Note that the \overline{BZ} pin is the inverse of the BZ pin which together generate a differential output which can supply more power to connected interfaces such as buzzers.

The buzzer is driven by the internal clock source, f_S , which is then passed through a divider, the division ratio of which is selected by configuration options to provide a range of buzzer frequencies from $f_S/2$ to $f_S/2^4$. The clock source that generates f_S , which in turn controls the buzzer frequency, can originate from three different sources, the RTC oscillator, the WDT oscillator or the System oscillator/4, the choice of which is determined by the f_S clock source configuration option. It is important to note that if the RTC oscillator is selected as the system clock, then f_S and correspondingly the buzzer, will also have the RTC oscillator as its clock source. Note that the buzzer frequency is controlled by configuration options, which select both the source clock for the internal clock f_S and the internal division ratio. There are no internal registers associated with the buzzer frequency.

If the configuration options have selected both pins PA0 and PA1 to function as a BZ and \overline{BZ} complementary pair of buzzer outputs, then for correct buzzer operation it is essential that both pins must be setup as outputs by setting bits PAC0 and PAC1 of the PAC port control register to zero. The PA0 data bit in the PA data register must also be set high to enable the buzzer outputs, if set low,

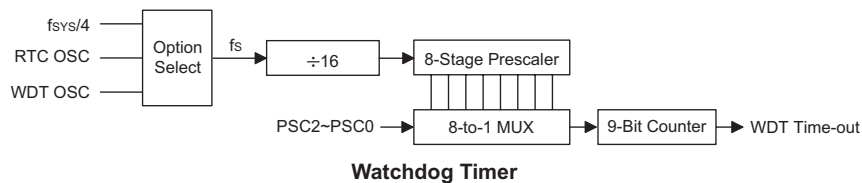

both pins PA0 and PA1 will remain low. In this way the single bit PA0 of the PA register can be used as an on/off control for both the BZ and $\overline{\text{BZ}}$ buzzer pin outputs. Note that the PA1 data bit in the PA register has no control over the $\overline{\text{BZ}}$ buzzer pin PA1.

PA0/PA1 Pin Function Control

PAC Register PAC0	PAC Register PAC1	PA Data Register PA0	PA Data Register PA1	Output Function
0	0	1	x	PA0=BZ PA1= $\overline{\text{BZ}}$
0	0	0	x	PA0="0" PA1="0"
0	1	1	x	PA0=BZ PA1=input line
0	1	0	x	PA0="0" PA1=input line
1	0	x	D	PA0=input line PA1=D
1	1	x	x	PA0=input line PA1=input line

Note: "x" stands for don't care
"D" stands for Data "0" or "1"

If configuration options have selected that only the PA0 pin is to function as a BZ buzzer pin, then the PA1 pin can be used as a normal I/O pin. For the PA0 pin to function as a BZ buzzer pin, PA0 must be setup as an output by setting bit PAC0 of the PAC port control register to zero. The PA0 data bit in the PA data register must also be set high to enable the buzzer output, if set low pin PA0 will remain low. In this way the PA0 bit can be used as an on/off control for the BZ buzzer pin PA0. If the PAC0 bit of the PAC port control register is set high, then pin PA0 can still be used as an input even though the configuration option has configured it as a BZ buzzer output.

Note that no matter what configuration option is chosen for the buzzer, if the port control register has setup the pin to function as an input, then this will override the configuration option selection and force the pin to always behave as an input pin. This arrangement enables the pin to be used as both a buzzer pin and as an input pin, so regardless of the configuration option chosen; the actual function of the pin can be changed dynamically by the application program by programming the appropriate port control register bit.

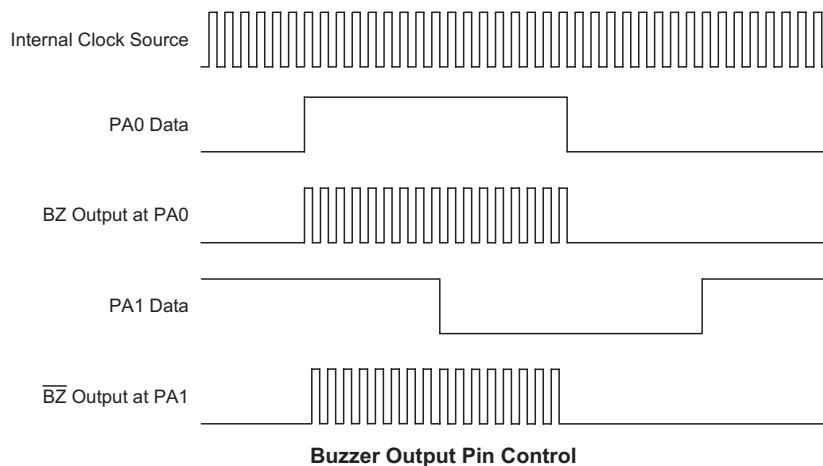

Note The above drawing shows the situation where both pins PA0 and PA1 are selected by configuration option to be BZ and $\overline{\text{BZ}}$ buzzer pin outputs. The Port Control Register of both pins must have already been setup as output. The data setup on pin PA1 has no effect on the buzzer outputs.

Configuration Options

Configuration options refer to certain options within the MCU that are programmed into the device during the programming process. During the development process, these options are selected using the HT-IDE software development tools. As these options are programmed into the device using the hardware programming tools, once they are selected they cannot be changed later as the application software has no control over the configuration options. All options must be defined for proper system function, the details of which are shown in the table.

No.	Options
I/O Options	
1	PA0~PA7: wake-up enable or disable - bit option
2	PA pull-high enable or disable - By port
Oscillator Option	
3	System oscillator: Crystal or RC
PWM Options	
4	PA4~PA5: PWM0~PWM1 function selection
5	PWM mode: 6+2 or 7+1 mode selection
Timer Options	
6	Timer/Event Counter clock sources: $f_{SYS}/4$ or f_{SP}
Buzzer Options	
7	Buzzer function: single BZ enable, both BZ and \overline{BZ} or both disable
8	Buzzer frequency: $f_S/2$, $f_S/4$, $f_S/8$, $f_S/16$
Time Base Options	
9	Time base time-out period: $f_S/2^5$, $f_S/2^6$, $f_S/2^7$, $f_S/2^8$, $f_S/2^9$, $f_S/2^{10}$, $f_S/2^{11}$, $f_S/2^{12}$
Watchdog Options	
10	Watchdog Timer clock source: WDT oscillator, RTC oscillator or $f_{SYS}/4$
11	Watchdog Timer function: enable or disable
12	CLRWDT instructions: 1 or 2 instructions
LVR Options	
13	LVR function: enable or disable
14	LVR voltage: 2.1V, 3.15V or 4.2V
Lock Options	
15	Lock All
16	Partial Lock

Application Circuits

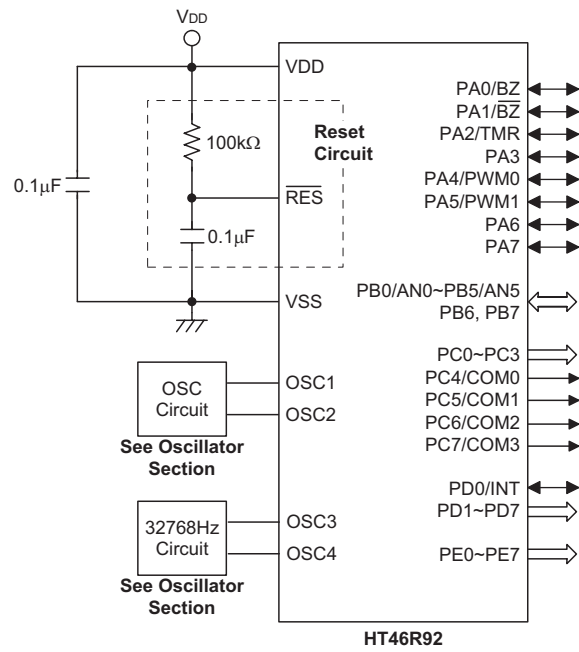

Instruction Set

Introduction

Central to the successful operation of any microcontroller is its instruction set, which is a set of program instruction codes that directs the microcontroller to perform certain operations. In the case of Holtek microcontrollers, a comprehensive and flexible set of over 60 instructions is provided to enable programmers to implement their application with the minimum of programming overheads.

For easier understanding of the various instruction codes, they have been subdivided into several functional groupings.

Instruction Timing

Most instructions are implemented within one instruction cycle. The exceptions to this are branch, call, or table read instructions where two instruction cycles are required. One instruction cycle is equal to 4 system clock cycles, therefore in the case of an 8MHz system oscillator, most instructions would be implemented within 0.5 μ s and branch or call instructions would be implemented within 1 μ s. Although instructions which require one more cycle to implement are generally limited to the JMP, CALL, RET, RETI and table read instructions, it is important to realize that any other instructions which involve manipulation of the Program Counter Low register or PCL will also take one more cycle to implement. As instructions which change the contents of the PCL will imply a direct jump to that new address, one more cycle will be required. Examples of such instructions would be "CLR PCL" or "MOV PCL, A". For the case of skip instructions, it must be noted that if the result of the comparison involves a skip operation then this will also take one more cycle, if no skip is involved then only one cycle is required.

Moving and Transferring Data

The transfer of data within the microcontroller program is one of the most frequently used operations. Making use of three kinds of MOV instructions, data can be transferred from registers to the Accumulator and vice-versa as well as being able to move specific immediate data directly into the Accumulator. One of the most important data transfer applications is to receive data from the input ports and transfer data to the output ports.

Arithmetic Operations

The ability to perform certain arithmetic operations and data manipulation is a necessary feature of most microcontroller applications. Within the Holtek microcontroller instruction set are a range of add and

subtract instruction mnemonics to enable the necessary arithmetic to be carried out. Care must be taken to ensure correct handling of carry and borrow data when results exceed 255 for addition and less than 0 for subtraction. The increment and decrement instructions INC, INCA, DEC and DECA provide a simple means of increasing or decreasing by a value of one of the values in the destination specified.

Logical and Rotate Operations

The standard logical operations such as AND, OR, XOR and CPL all have their own instruction within the Holtek microcontroller instruction set. As with the case of most instructions involving data manipulation, data must pass through the Accumulator which may involve additional programming steps. In all logical data operations, the zero flag may be set if the result of the operation is zero. Another form of logical data manipulation comes from the rotate instructions such as RR, RL, RRC and RLC which provide a simple means of rotating one bit right or left. Different rotate instructions exist depending on program requirements. Rotate instructions are useful for serial port programming applications where data can be rotated from an internal register into the Carry bit from where it can be examined and the necessary serial bit set high or low. Another application where rotate data operations are used is to implement multiplication and division calculations.

Branches and Control Transfer

Program branching takes the form of either jumps to specified locations using the JMP instruction or to a subroutine using the CALL instruction. They differ in the sense that in the case of a subroutine call, the program must return to the instruction immediately when the subroutine has been carried out. This is done by placing a return instruction RET in the subroutine which will cause the program to jump back to the address right after the CALL instruction. In the case of a JMP instruction, the program simply jumps to the desired location. There is no requirement to jump back to the original jumping off point as in the case of the CALL instruction. One special and extremely useful set of branch instructions are the conditional branches. Here a decision is first made regarding the condition of a certain data memory or individual bits. Depending upon the conditions, the program will continue with the next instruction or skip over it and jump to the following instruction. These instructions are the key to decision making and branching within the program perhaps determined by the condition of certain input switches or by the condition of internal data bits.

Bit Operations

The ability to provide single bit operations on Data Memory is an extremely flexible feature of all Holtek microcontrollers. This feature is especially useful for output port bit programming where individual bits or port pins can be directly set high or low using either the "SET [m].i" or "CLR [m].i" instructions respectively. The feature removes the need for programmers to first read the 8-bit output port, manipulate the input data to ensure that other bits are not changed and then output the port with the correct new data. This read-modify-write process is taken care of automatically when these bit operation instructions are used.

Table Read Operations

Data storage is normally implemented by using registers. However, when working with large amounts of fixed data, the volume involved often makes it inconvenient to store the fixed data in the Data Memory. To overcome this problem, Holtek microcontrollers allow an area of Program Memory to be setup as a table where data can be directly stored. A set of easy to use instructions provides the means by which this fixed data can be referenced and retrieved from the Program Memory.

Other Operations

In addition to the above functional instructions, a range of other instructions also exist such as the "HALT" instruction for Power-down operations and instructions to control the operation of the Watchdog Timer for reliable program operations under extreme electric or electromagnetic environments. For their relevant operations, refer to the functional related sections.

Instruction Set Summary

The following table depicts a summary of the instruction set categorised according to function and can be consulted as a basic instruction reference using the following listed conventions.

Table conventions:

x: Bits immediate data

m: Data Memory address

A: Accumulator

i: 0-7 number of bits

addr: Program memory address

Mnemonic	Description	Cycles	Flag Affected
Arithmetic			
ADD A,[m]	Add Data Memory to ACC	1	Z, C, AC, OV
ADDM A,[m]	Add ACC to Data Memory	1 ^{Note}	Z, C, AC, OV
ADD A,x	Add immediate data to ACC	1	Z, C, AC, OV
ADC A,[m]	Add Data Memory to ACC with Carry	1	Z, C, AC, OV
ADCM A,[m]	Add ACC to Data memory with Carry	1 ^{Note}	Z, C, AC, OV
SUB A,x	Subtract immediate data from the ACC	1	Z, C, AC, OV
SUB A,[m]	Subtract Data Memory from ACC	1	Z, C, AC, OV
SUBM A,[m]	Subtract Data Memory from ACC with result in Data Memory	1 ^{Note}	Z, C, AC, OV
SBC A,[m]	Subtract Data Memory from ACC with Carry	1	Z, C, AC, OV
SBCM A,[m]	Subtract Data Memory from ACC with Carry, result in Data Memory	1 ^{Note}	Z, C, AC, OV
DAA [m]	Decimal adjust ACC for Addition with result in Data Memory	1 ^{Note}	C
Logic Operation			
AND A,[m]	Logical AND Data Memory to ACC	1	Z
OR A,[m]	Logical OR Data Memory to ACC	1	Z
XOR A,[m]	Logical XOR Data Memory to ACC	1	Z
ANDM A,[m]	Logical AND ACC to Data Memory	1 ^{Note}	Z
ORM A,[m]	Logical OR ACC to Data Memory	1 ^{Note}	Z
XORM A,[m]	Logical XOR ACC to Data Memory	1 ^{Note}	Z
AND A,x	Logical AND immediate Data to ACC	1	Z
OR A,x	Logical OR immediate Data to ACC	1	Z
XOR A,x	Logical XOR immediate Data to ACC	1	Z
CPL [m]	Complement Data Memory	1 ^{Note}	Z
CPLA [m]	Complement Data Memory with result in ACC	1	Z
Increment & Decrement			
INCA [m]	Increment Data Memory with result in ACC	1	Z
INC [m]	Increment Data Memory	1 ^{Note}	Z
DECA [m]	Decrement Data Memory with result in ACC	1	Z
DEC [m]	Decrement Data Memory	1 ^{Note}	Z

Mnemonic	Description	Cycles	Flag Affected
Rotate			
RRA [m]	Rotate Data Memory right with result in ACC	1	None
RR [m]	Rotate Data Memory right	¹ Note	None
RRCA [m]	Rotate Data Memory right through Carry with result in ACC	1	C
RRC [m]	Rotate Data Memory right through Carry	¹ Note	C
RLA [m]	Rotate Data Memory left with result in ACC	1	None
RL [m]	Rotate Data Memory left	¹ Note	None
RLCA [m]	Rotate Data Memory left through Carry with result in ACC	1	C
RLC [m]	Rotate Data Memory left through Carry	¹ Note	C
Data Move			
MOV A,[m]	Move Data Memory to ACC	1	None
MOV [m],A	Move ACC to Data Memory	¹ Note	None
MOV A,x	Move immediate data to ACC	1	None
Bit Operation			
CLR [m].i	Clear bit of Data Memory	¹ Note	None
SET [m].i	Set bit of Data Memory	¹ Note	None
Branch			
JMP addr	Jump unconditionally	2	None
SZ [m]	Skip if Data Memory is zero	¹ Note	None
SZA [m]	Skip if Data Memory is zero with data movement to ACC	¹ note	None
SZ [m].i	Skip if bit i of Data Memory is zero	¹ Note	None
SNZ [m].i	Skip if bit i of Data Memory is not zero	¹ Note	None
SIZ [m]	Skip if increment Data Memory is zero	¹ Note	None
SDZ [m]	Skip if decrement Data Memory is zero	¹ Note	None
SIZA [m]	Skip if increment Data Memory is zero with result in ACC	¹ Note	None
SDZA [m]	Skip if decrement Data Memory is zero with result in ACC	¹ Note	None
CALL addr	Subroutine call	2	None
RET	Return from subroutine	2	None
RET A,x	Return from subroutine and load immediate data to ACC	2	None
RETI	Return from interrupt	2	None
Table Read			
TABRDC [m]	Read table (current page) to TBLH and Data Memory	2 ^{Note}	None
TABRDL [m]	Read table (last page) to TBLH and Data Memory	2 ^{Note}	None
Miscellaneous			
NOP	No operation	1	None
CLR [m]	Clear Data Memory	¹ Note	None
SET [m]	Set Data Memory	¹ Note	None
CLR WDT	Clear Watchdog Timer	1	TO, PDF
CLR WDT1	Pre-clear Watchdog Timer	1	TO, PDF
CLR WDT2	Pre-clear Watchdog Timer	1	TO, PDF
SWAP [m]	Swap nibbles of Data Memory	¹ Note	None
SWAPA [m]	Swap nibbles of Data Memory with result in ACC	1	None
HALT	Enter power down mode	1	TO, PDF

Note: 1. For skip instructions, if the result of the comparison involves a skip then two cycles are required, if no skip takes place only one cycle is required.
2. Any instruction which changes the contents of the PCL will also require 2 cycles for execution.
3. For the "CLR WDT1" and "CLR WDT2" instructions the TO and PDF flags may be affected by the execution status. The TO and PDF flags are cleared after both "CLR WDT1" and "CLR WDT2" instructions are consecutively executed. Otherwise the TO and PDF flags remain unchanged.

Instruction Definition

ADC A,[m]	Add Data Memory to ACC with Carry
Description	The contents of the specified Data Memory, Accumulator and the carry flag are added. The result is stored in the Accumulator.
Operation	$ACC \leftarrow ACC + [m] + C$
Affected flag(s)	OV, Z, AC, C
ADCM A,[m]	Add ACC to Data Memory with Carry
Description	The contents of the specified Data Memory, Accumulator and the carry flag are added. The result is stored in the specified Data Memory.
Operation	$[m] \leftarrow ACC + [m] + C$
Affected flag(s)	OV, Z, AC, C
ADD A,[m]	Add Data Memory to ACC
Description	The contents of the specified Data Memory and the Accumulator are added. The result is stored in the Accumulator.
Operation	$ACC \leftarrow ACC + [m]$
Affected flag(s)	OV, Z, AC, C
ADD A,x	Add immediate data to ACC
Description	The contents of the Accumulator and the specified immediate data are added. The result is stored in the Accumulator.
Operation	$ACC \leftarrow ACC + x$
Affected flag(s)	OV, Z, AC, C
ADDM A,[m]	Add ACC to Data Memory
Description	The contents of the specified Data Memory and the Accumulator are added. The result is stored in the specified Data Memory.
Operation	$[m] \leftarrow ACC + [m]$
Affected flag(s)	OV, Z, AC, C
AND A,[m]	Logical AND Data Memory to ACC
Description	Data in the Accumulator and the specified Data Memory perform a bitwise logical AND operation. The result is stored in the Accumulator.
Operation	$ACC \leftarrow ACC \text{ "AND" } [m]$
Affected flag(s)	Z
AND A,x	Logical AND immediate data to ACC
Description	Data in the Accumulator and the specified immediate data perform a bitwise logical AND operation. The result is stored in the Accumulator.
Operation	$ACC \leftarrow ACC \text{ "AND" } x$
Affected flag(s)	Z
ANDM A,[m]	Logical AND ACC to Data Memory
Description	Data in the specified Data Memory and the Accumulator perform a bitwise logical AND operation. The result is stored in the Data Memory.
Operation	$[m] \leftarrow ACC \text{ "AND" } [m]$
Affected flag(s)	Z

CALL addr	Subroutine call
Description	Unconditionally calls a subroutine at the specified address. The Program Counter then increments by 1 to obtain the address of the next instruction which is then pushed onto the stack. The specified address is then loaded and the program continues execution from this new address. As this instruction requires an additional operation, it is a two cycle instruction.
Operation	Stack \leftarrow Program Counter + 1 Program Counter \leftarrow addr
Affected flag(s)	None
CLR [m]	Clear Data Memory
Description	Each bit of the specified Data Memory is cleared to 0.
Operation	[m] \leftarrow 00H
Affected flag(s)	None
CLR [m].i	Clear bit of Data Memory
Description	Bit i of the specified Data Memory is cleared to 0.
Operation	[m].i \leftarrow 0
Affected flag(s)	None
CLR WDT	Clear Watchdog Timer
Description	The TO, PDF flags and the WDT are all cleared.
Operation	WDT cleared TO \leftarrow 0 PDF \leftarrow 0
Affected flag(s)	TO, PDF
CLR WDT1	Pre-clear Watchdog Timer
Description	The TO, PDF flags and the WDT are all cleared. Note that this instruction works in conjunction with CLR WDT2 and must be executed alternately with CLR WDT2 to have effect. Repeatedly executing this instruction without alternately executing CLR WDT2 will have no effect.
Operation	WDT cleared TO \leftarrow 0 PDF \leftarrow 0
Affected flag(s)	TO, PDF
CLR WDT2	Pre-clear Watchdog Timer
Description	The TO, PDF flags and the WDT are all cleared. Note that this instruction works in conjunction with CLR WDT1 and must be executed alternately with CLR WDT1 to have effect. Repeatedly executing this instruction without alternately executing CLR WDT1 will have no effect.
Operation	WDT cleared TO \leftarrow 0 PDF \leftarrow 0
Affected flag(s)	TO, PDF

CPL [m]	Complement Data Memory
Description	Each bit of the specified Data Memory is logically complemented (1's complement). Bits which previously contained a 1 are changed to 0 and vice versa.
Operation	$[m] \leftarrow \overline{[m]}$
Affected flag(s)	Z
CPLA [m]	Complement Data Memory with result in ACC
Description	Each bit of the specified Data Memory is logically complemented (1's complement). Bits which previously contained a 1 are changed to 0 and vice versa. The complemented result is stored in the Accumulator and the contents of the Data Memory remain unchanged.
Operation	$ACC \leftarrow \overline{[m]}$
Affected flag(s)	Z
DAA [m]	Decimal-Adjust ACC for addition with result in Data Memory
Description	Convert the contents of the Accumulator value to a BCD (Binary Coded Decimal) value resulting from the previous addition of two BCD variables. If the low nibble is greater than 9 or if AC flag is set, then a value of 6 will be added to the low nibble. Otherwise the low nibble remains unchanged. If the high nibble is greater than 9 or if the C flag is set, then a value of 6 will be added to the high nibble. Essentially, the decimal conversion is performed by adding 00H, 06H, 60H or 66H depending on the Accumulator and flag conditions. Only the C flag may be affected by this instruction which indicates that if the original BCD sum is greater than 100, it allows multiple precision decimal addition.
Operation	$[m] \leftarrow ACC + 00H$ or $[m] \leftarrow ACC + 06H$ or $[m] \leftarrow ACC + 60H$ or $[m] \leftarrow ACC + 66H$
Affected flag(s)	C
DEC [m]	Decrement Data Memory
Description	Data in the specified Data Memory is decremented by 1.
Operation	$[m] \leftarrow [m] - 1$
Affected flag(s)	Z
DECA [m]	Decrement Data Memory with result in ACC
Description	Data in the specified Data Memory is decremented by 1. The result is stored in the Accumulator. The contents of the Data Memory remain unchanged.
Operation	$ACC \leftarrow [m] - 1$
Affected flag(s)	Z
HALT	Enter power down mode
Description	This instruction stops the program execution and turns off the system clock. The contents of the Data Memory and registers are retained. The WDT and prescaler are cleared. The power down flag PDF is set and the WDT time-out flag TO is cleared.
Operation	$TO \leftarrow 0$ $PDF \leftarrow 1$
Affected flag(s)	TO, PDF

INC [m]	Increment Data Memory
Description	Data in the specified Data Memory is incremented by 1.
Operation	$[m] \leftarrow [m] + 1$
Affected flag(s)	Z
INCA [m]	Increment Data Memory with result in ACC
Description	Data in the specified Data Memory is incremented by 1. The result is stored in the Accumulator. The contents of the Data Memory remain unchanged.
Operation	$ACC \leftarrow [m] + 1$
Affected flag(s)	Z
JMP addr	Jump unconditionally
Description	The contents of the Program Counter are replaced with the specified address. Program execution then continues from this new address. As this requires the insertion of a dummy instruction while the new address is loaded, it is a two cycle instruction.
Operation	$Program\ Counter \leftarrow addr$
Affected flag(s)	None
MOV A,[m]	Move Data Memory to ACC
Description	The contents of the specified Data Memory are copied to the Accumulator.
Operation	$ACC \leftarrow [m]$
Affected flag(s)	None
MOV A,x	Move immediate data to ACC
Description	The immediate data specified is loaded into the Accumulator.
Operation	$ACC \leftarrow x$
Affected flag(s)	None
MOV [m],A	Move ACC to Data Memory
Description	The contents of the Accumulator are copied to the specified Data Memory.
Operation	$[m] \leftarrow ACC$
Affected flag(s)	None
NOP	No operation
Description	No operation is performed. Execution continues with the next instruction.
Operation	No operation
Affected flag(s)	None
OR A,[m]	Logical OR Data Memory to ACC
Description	Data in the Accumulator and the specified Data Memory perform a bitwise logical OR operation. The result is stored in the Accumulator.
Operation	$ACC \leftarrow ACC \text{ "OR" } [m]$
Affected flag(s)	Z

OR A,x	Logical OR immediate data to ACC
Description	Data in the Accumulator and the specified immediate data perform a bitwise logical OR operation. The result is stored in the Accumulator.
Operation	ACC ← ACC "OR" x
Affected flag(s)	Z
ORM A,[m]	Logical OR ACC to Data Memory
Description	Data in the specified Data Memory and the Accumulator perform a bitwise logical OR operation. The result is stored in the Data Memory.
Operation	[m] ← ACC "OR" [m]
Affected flag(s)	Z
RET	Return from subroutine
Description	The Program Counter is restored from the stack. Program execution continues at the restored address.
Operation	Program Counter ← Stack
Affected flag(s)	None
RET A,x	Return from subroutine and load immediate data to ACC
Description	The Program Counter is restored from the stack and the Accumulator loaded with the specified immediate data. Program execution continues at the restored address.
Operation	Program Counter ← Stack ACC ← x
Affected flag(s)	None
RETI	Return from interrupt
Description	The Program Counter is restored from the stack and the interrupts are re-enabled by setting the EMI bit. EMI is the master interrupt global enable bit. If an interrupt was pending when the RETI instruction is executed, the pending Interrupt routine will be processed before returning to the main program.
Operation	Program Counter ← Stack EMI ← 1
Affected flag(s)	None
RL [m]	Rotate Data Memory left
Description	The contents of the specified Data Memory are rotated left by 1 bit with bit 7 rotated into bit 0.
Operation	[m].(i+1) ← [m].i; (i = 0~6) [m].0 ← [m].7
Affected flag(s)	None
RLA [m]	Rotate Data Memory left with result in ACC
Description	The contents of the specified Data Memory are rotated left by 1 bit with bit 7 rotated into bit 0. The rotated result is stored in the Accumulator and the contents of the Data Memory remain unchanged.
Operation	ACC.(i+1) ← [m].i; (i = 0~6) ACC.0 ← [m].7
Affected flag(s)	None

RLC [m]	Rotate Data Memory left through Carry
Description	The contents of the specified Data Memory and the carry flag are rotated left by 1 bit. Bit 7 replaces the Carry bit and the original carry flag is rotated into bit 0.
Operation	$[m].(i+1) \leftarrow [m].i; (i = 0\sim6)$ $[m].0 \leftarrow C$ $C \leftarrow [m].7$
Affected flag(s)	C
RLCA [m]	Rotate Data Memory left through Carry with result in ACC
Description	Data in the specified Data Memory and the carry flag are rotated left by 1 bit. Bit 7 replaces the Carry bit and the original carry flag is rotated into the bit 0. The rotated result is stored in the Accumulator and the contents of the Data Memory remain unchanged.
Operation	$ACC.(i+1) \leftarrow [m].i; (i = 0\sim6)$ $ACC.0 \leftarrow C$ $C \leftarrow [m].7$
Affected flag(s)	C
RR [m]	Rotate Data Memory right
Description	The contents of the specified Data Memory are rotated right by 1 bit with bit 0 rotated into bit 7.
Operation	$[m].i \leftarrow [m].(i+1); (i = 0\sim6)$ $[m].7 \leftarrow [m].0$
Affected flag(s)	None
RRA [m]	Rotate Data Memory right with result in ACC
Description	Data in the specified Data Memory and the carry flag are rotated right by 1 bit with bit 0 rotated into bit 7. The rotated result is stored in the Accumulator and the contents of the Data Memory remain unchanged.
Operation	$ACC.i \leftarrow [m].(i+1); (i = 0\sim6)$ $ACC.7 \leftarrow [m].0$
Affected flag(s)	None
RRC [m]	Rotate Data Memory right through Carry
Description	The contents of the specified Data Memory and the carry flag are rotated right by 1 bit. Bit 0 replaces the Carry bit and the original carry flag is rotated into bit 7.
Operation	$[m].i \leftarrow [m].(i+1); (i = 0\sim6)$ $[m].7 \leftarrow C$ $C \leftarrow [m].0$
Affected flag(s)	C
RRCA [m]	Rotate Data Memory right through Carry with result in ACC
Description	Data in the specified Data Memory and the carry flag are rotated right by 1 bit. Bit 0 replaces the Carry bit and the original carry flag is rotated into bit 7. The rotated result is stored in the Accumulator and the contents of the Data Memory remain unchanged.
Operation	$ACC.i \leftarrow [m].(i+1); (i = 0\sim6)$ $ACC.7 \leftarrow C$ $C \leftarrow [m].0$
Affected flag(s)	C

SBC A,[m]	Subtract Data Memory from ACC with Carry
Description	The contents of the specified Data Memory and the complement of the carry flag are subtracted from the Accumulator. The result is stored in the Accumulator. Note that if the result of subtraction is negative, the C flag will be cleared to 0, otherwise if the result is positive or zero, the C flag will be set to 1.
Operation	$ACC \leftarrow ACC - [m] - \bar{C}$
Affected flag(s)	OV, Z, AC, C
SBCM A,[m]	Subtract Data Memory from ACC with Carry and result in Data Memory
Description	The contents of the specified Data Memory and the complement of the carry flag are subtracted from the Accumulator. The result is stored in the Data Memory. Note that if the result of subtraction is negative, the C flag will be cleared to 0, otherwise if the result is positive or zero, the C flag will be set to 1.
Operation	$[m] \leftarrow ACC - [m] - \bar{C}$
Affected flag(s)	OV, Z, AC, C
SDZ [m]	Skip if decrement Data Memory is 0
Description	The contents of the specified Data Memory are first decremented by 1. If the result is 0 the following instruction is skipped. As this requires the insertion of a dummy instruction while the next instruction is fetched, it is a two cycle instruction. If the result is not 0 the program proceeds with the following instruction.
Operation	$[m] \leftarrow [m] - 1$ Skip if $[m] = 0$
Affected flag(s)	None
SDZA [m]	Skip if decrement Data Memory is zero with result in ACC
Description	The contents of the specified Data Memory are first decremented by 1. If the result is 0, the following instruction is skipped. The result is stored in the Accumulator but the specified Data Memory contents remain unchanged. As this requires the insertion of a dummy instruction while the next instruction is fetched, it is a two cycle instruction. If the result is not 0, the program proceeds with the following instruction.
Operation	$ACC \leftarrow [m] - 1$ Skip if $ACC = 0$
Affected flag(s)	None
SET [m]	Set Data Memory
Description	Each bit of the specified Data Memory is set to 1.
Operation	$[m] \leftarrow FFH$
Affected flag(s)	None
SET [m].i	Set bit of Data Memory
Description	Bit i of the specified Data Memory is set to 1.
Operation	$[m].i \leftarrow 1$
Affected flag(s)	None

SIZ [m]	Skip if increment Data Memory is 0
Description	The contents of the specified Data Memory are first incremented by 1. If the result is 0, the following instruction is skipped. As this requires the insertion of a dummy instruction while the next instruction is fetched, it is a two cycle instruction. If the result is not 0 the program proceeds with the following instruction.
Operation	$[m] \leftarrow [m] + 1$ Skip if $[m] = 0$
Affected flag(s)	None
SIZA [m]	Skip if increment Data Memory is zero with result in ACC
Description	The contents of the specified Data Memory are first incremented by 1. If the result is 0, the following instruction is skipped. The result is stored in the Accumulator but the specified Data Memory contents remain unchanged. As this requires the insertion of a dummy instruction while the next instruction is fetched, it is a two cycle instruction. If the result is not 0 the program proceeds with the following instruction.
Operation	$ACC \leftarrow [m] + 1$ Skip if $ACC = 0$
Affected flag(s)	None
SNZ [m].i	Skip if bit i of Data Memory is not 0
Description	If bit i of the specified Data Memory is not 0, the following instruction is skipped. As this requires the insertion of a dummy instruction while the next instruction is fetched, it is a two cycle instruction. If the result is 0 the program proceeds with the following instruction.
Operation	Skip if $[m].i \neq 0$
Affected flag(s)	None
SUB A,[m]	Subtract Data Memory from ACC
Description	The specified Data Memory is subtracted from the contents of the Accumulator. The result is stored in the Accumulator. Note that if the result of subtraction is negative, the C flag will be cleared to 0, otherwise if the result is positive or zero, the C flag will be set to 1.
Operation	$ACC \leftarrow ACC - [m]$
Affected flag(s)	OV, Z, AC, C
SUBM A,[m]	Subtract Data Memory from ACC with result in Data Memory
Description	The specified Data Memory is subtracted from the contents of the Accumulator. The result is stored in the Data Memory. Note that if the result of subtraction is negative, the C flag will be cleared to 0, otherwise if the result is positive or zero, the C flag will be set to 1.
Operation	$[m] \leftarrow ACC - [m]$
Affected flag(s)	OV, Z, AC, C
SUB A,x	Subtract immediate data from ACC
Description	The immediate data specified by the code is subtracted from the contents of the Accumulator. The result is stored in the Accumulator. Note that if the result of subtraction is negative, the C flag will be cleared to 0, otherwise if the result is positive or zero, the C flag will be set to 1.
Operation	$ACC \leftarrow ACC - x$
Affected flag(s)	OV, Z, AC, C

SWAP [m]	Swap nibbles of Data Memory
Description	The low-order and high-order nibbles of the specified Data Memory are interchanged.
Operation	$[m].3 \sim [m].0 \leftrightarrow [m].7 \sim [m].4$
Affected flag(s)	None
SWAPA [m]	Swap nibbles of Data Memory with result in ACC
Description	The low-order and high-order nibbles of the specified Data Memory are interchanged. The result is stored in the Accumulator. The contents of the Data Memory remain unchanged.
Operation	$ACC.3 \sim ACC.0 \leftarrow [m].7 \sim [m].4$ $ACC.7 \sim ACC.4 \leftarrow [m].3 \sim [m].0$
Affected flag(s)	None
SZ [m]	Skip if Data Memory is 0
Description	If the contents of the specified Data Memory is 0, the following instruction is skipped. As this requires the insertion of a dummy instruction while the next instruction is fetched, it is a two cycle instruction. If the result is not 0 the program proceeds with the following instruction.
Operation	Skip if $[m] = 0$
Affected flag(s)	None
SZA [m]	Skip if Data Memory is 0 with data movement to ACC
Description	The contents of the specified Data Memory are copied to the Accumulator. If the value is zero, the following instruction is skipped. As this requires the insertion of a dummy instruction while the next instruction is fetched, it is a two cycle instruction. If the result is not 0 the program proceeds with the following instruction.
Operation	$ACC \leftarrow [m]$ Skip if $[m] = 0$
Affected flag(s)	None
SZ [m].i	Skip if bit i of Data Memory is 0
Description	If bit i of the specified Data Memory is 0, the following instruction is skipped. As this requires the insertion of a dummy instruction while the next instruction is fetched, it is a two cycle instruction. If the result is not 0, the program proceeds with the following instruction.
Operation	Skip if $[m].i = 0$
Affected flag(s)	None
TABRDC [m]	Read table (current page) to TBLH and Data Memory
Description	The low byte of the program code (current page) addressed by the table pointer (TBLP) is moved to the specified Data Memory and the high byte moved to TBLH.
Operation	$[m] \leftarrow$ program code (low byte) $TBLH \leftarrow$ program code (high byte)
Affected flag(s)	None
TABRDL [m]	Read table (last page) to TBLH and Data Memory
Description	The low byte of the program code (last page) addressed by the table pointer (TBLP) is moved to the specified Data Memory and the high byte moved to TBLH.
Operation	$[m] \leftarrow$ program code (low byte) $TBLH \leftarrow$ program code (high byte)
Affected flag(s)	None

XOR A,[m]	Logical XOR Data Memory to ACC
Description	Data in the Accumulator and the specified Data Memory perform a bitwise logical XOR operation. The result is stored in the Accumulator.
Operation	ACC ← ACC "XOR" [m]
Affected flag(s)	Z
XORM A,[m]	Logical XOR ACC to Data Memory
Description	Data in the specified Data Memory and the Accumulator perform a bitwise logical XOR operation. The result is stored in the Data Memory.
Operation	[m] ← ACC "XOR" [m]
Affected flag(s)	Z
XOR A,x	Logical XOR immediate data to ACC
Description	Data in the Accumulator and the specified immediate data perform a bitwise logical XOR operation. The result is stored in the Accumulator.
Operation	ACC ← ACC "XOR" x
Affected flag(s)	Z

Package Information

44-pin QFP (10mm×10mm) Outline Dimensions

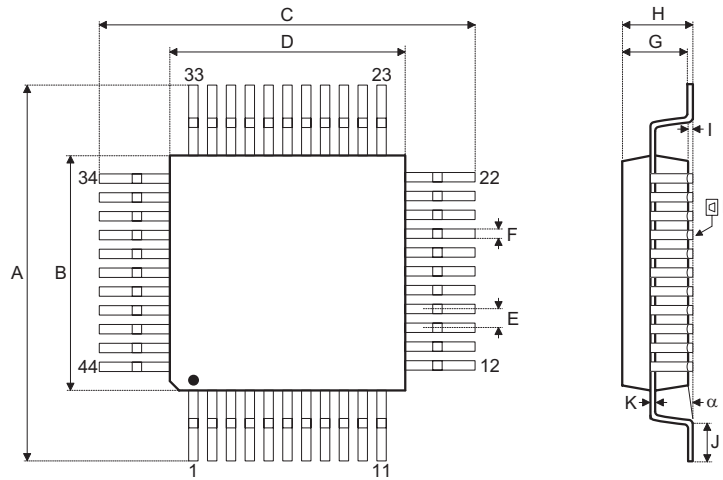

Symbol	Dimensions in mm		
	Min.	Nom.	Max.
A	13	—	13.4
B	9.9	—	10.1
C	13	—	13.4
D	9.9	—	10.1
E	—	0.8	—
F	—	0.3	—
G	1.9	—	2.2
H	—	—	2.7
I	0.25	—	0.5
J	0.73	—	0.93
K	0.1	—	0.2
L	—	0.1	—
α	0°	—	7°

52-pin QFP (14mm×14mm) Outline Dimensions

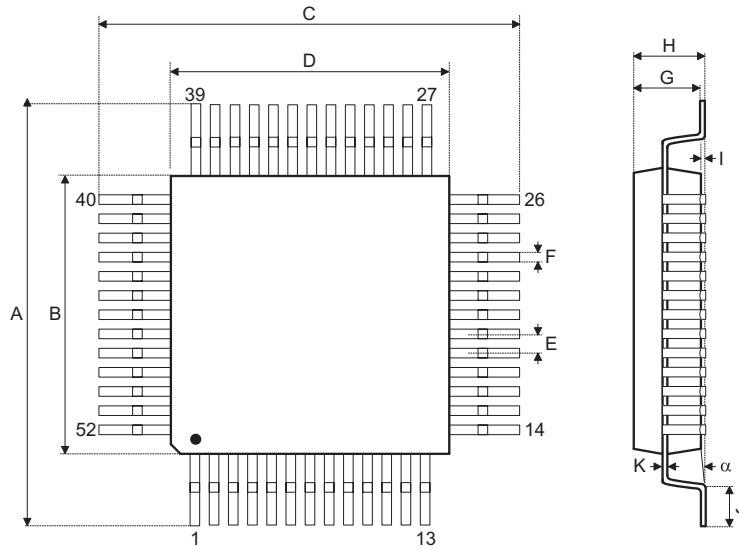

Symbol	Dimensions in mm		
	Min.	Nom.	Max.
A	17.3	—	17.5
B	13.9	—	14.1
C	17.3	—	17.5
D	13.9	—	14.1
E	—	1	—
F	—	0.4	—
G	2.5	—	3.1
H	—	—	3.4
I	—	0.1	—
J	0.73	—	1.03
K	0.1	—	0.2
α	0°	—	7°

Holtek Semiconductor Inc. (Headquarters)

No.3, Creation Rd. II, Science Park, Hsinchu, Taiwan
Tel: 886-3-563-1999
Fax: 886-3-563-1189
<http://www.holtek.com.tw>

Holtek Semiconductor Inc. (Taipei Sales Office)

4F-2, No. 3-2, YuanQu St., Nankang Software Park, Taipei 115, Taiwan
Tel: 886-2-2655-7070
Fax: 886-2-2655-7373
Fax: 886-2-2655-7383 (International sales hotline)

Holtek Semiconductor (China) Inc. (Dongguan Sales Office)

Building No. 10, Xinzhu Court, (No. 1 Headquarters), 4 Cuizhu Road, Songshan Lake, Dongguan, China 523808
Tel: 86-769-2626-1300
Fax: 86-769-2626-1311

Holtek Semiconductor (USA), Inc. (North America Sales Office)

46729 Fremont Blvd., Fremont, CA 94538, USA
Tel: 1-510-252-9880
Fax: 1-510-252-9885
<http://www.holtek.com>

Copyright © 2008 by HOLTEK SEMICONDUCTOR INC.

The information appearing in this Data Sheet is believed to be accurate at the time of publication. However, Holtek assumes no responsibility arising from the use of the specifications described. The applications mentioned herein are used solely for the purpose of illustration and Holtek makes no warranty or representation that such applications will be suitable without further modification, nor recommends the use of its products for application that may present a risk to human life due to malfunction or otherwise. Holtek's products are not authorized for use as critical components in life support devices or systems. Holtek reserves the right to alter its products without prior notification. For the most up-to-date information, please visit our web site at <http://www.holtek.com.tw>.