

Thyristor/Diode Presspack stack

Electrical Characteristics						
Symbol	Conditions		min	typ	max	Unit
Electrical Data						
$I_D$	Maximum DC current	$T_{AMBIENT} = 35^{\circ}C$ ; No overload		845		A
$V_{AC}$	Maximum AC voltage (+/-10%)			500		$V_{AC}$
$V_{BUS}$	DC Bus voltage			670		$V_{DC}$
$P_{TOTAL}$	Maximum stack power			565		kW
$P_{LOSS}$	Stack power loss ( $T_{AMBIENT} = 35^{\circ}C$ )					W

Environmental Data						
Symbol	Conditions		min	typ	max	Unit
Mechanical Data						
Drawing	SEMIKRON document number.revision.version			11110416.01.B		-
Weight	Approximate total weight			106.0		kg
Altitude	Installation altitude without derating				1 000	m
Protection	IEC 60529			IP00		-
Pollution degree	EN 50178			2		-

## SEMISTACK® CLASSICS - B6HK

Three phase half-controlled rectifier

### Preliminary Data

Ordering No. 08800498  
Description SKS 845N B6HK 570 V16 SU

### Features

- Non-isolated power stacks
- SKN 1500/16 / SKT 760/16
- Heatsink U3/515
- Natural cooling
- RC circuit included
- Fuses with microswitches

### Typical Applications

- Soft charge
- Industrial heating

### Remarks

This technical information specifies semiconductor devices but promises no characteristics. No warranty or guarantee, expressed or implied, is made regarding delivery, performance or suitability.

Stack Protection						
Symbol	Conditions		min	typ	max	Unit
RC Circuit						
Type	RC in parallel with each electrical switch			-		-
R	Resistance (80W)			33		Ohm
C				0.47		$\mu F$

Fuses						
Symbol	Conditions		min	typ	max	Unit
Size	1 fuse per phase, with microswitches			33		-
$I_{N,RMS}$	Caliber			1 250		A
$U_N$	Nominal voltage (IEC)			690		V
$I^2t$	Total at $U_N$ at room temperature (approx. 20...25°C)				1 942.5	$kA^2s$

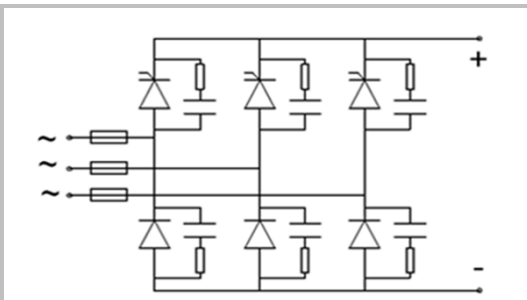

B6HK

