

Electrical Characteristics						
Symbol	Conditions		min	typ	max	Unit
Electrical Data						
I_D	Maximum DC current	$T_{AMBIENT} = 35^{\circ}C$; No overload		570		A
V_{AC}	Maximum AC voltage (+/-10%)			500		V_{AC}
V_{BUS}	DC Bus voltage			670		V_{DC}
P_{TOTAL}	Maximum stack power			380		kW
P_{LOSS}	Stack power loss ($T_{AMBIENT} = 35^{\circ}C$)					W

Environmental Data						
Symbol	Conditions		min	typ	max	Unit
Mechanical Data						
Drawing	SEMIKRON document number.revision.version			12100512.00.B		-
Weight	Approximate total weight			15.5		kg
Altitude	Installation altitude without derating				1 000	m
Protection	IEC 60529			IP00		-
Pollution degree	EN 50178			2		-

Fan Data						
Symbol	Conditions		min	typ	max	Unit
Type	SEMIKRON fan designation			SKF 16A-230-11		-
V_{FAN}	Fan voltage			230		V_{AC}
f_{FAN}	Fan frequency			50/60		Hz
I_{FAN}	Fan maximum input current			0.60/0.68		A
P_{FAN}	Fan power			135/154		W

Stack Protection						
Symbol	Conditions		min	typ	max	Unit
RC Circuit						
Type	RC in parallel with each electrical switch			RC47		-
R	Resistance (11W)			47		Ohm
C				0.22		μF

Fuses						
Symbol	Conditions		min	typ	max	Unit
Size	1 fuse per phase, with microswitches			31		-
$I_{N RMS}$	Caliber			700		A
U_N	Nominal voltage (IEC)			690		V
I^2t	Total at U_N at room temperature (approx. 20...25°C)			514.5		kA^2s

Bimetal Thermal Trip						
Symbol	Conditions		min	typ	max	Unit
T_S	Switching temperature over which thermal trip is open			85		$^{\circ}C$
$I_{TC MAX}$	Maximum permissible current			1		A
				3		A

SEMISTACK® CLASSICS - B6HK

Three phase half-controlled rectifier

Preliminary Data

Ordering No. 08800513
Description SKS 570F B6HK 380 V16 SU

Features

- Isolated power stacks
- SKKH 323/16
- Heatsink P16/200
- Forced air cooling
- RC circuit included
- Fuses with microswitches
- Thermal trip included

Typical Applications

- Soft charge
- Industrial heating

Remarks

This technical information specifies semiconductor devices but promises no characteristics. No warranty or guarantee, expressed or implied, is made regarding delivery, performance or suitability.

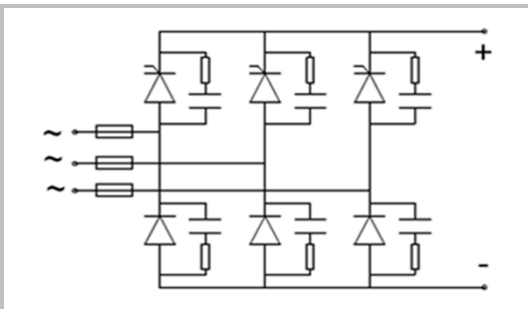

B6HK

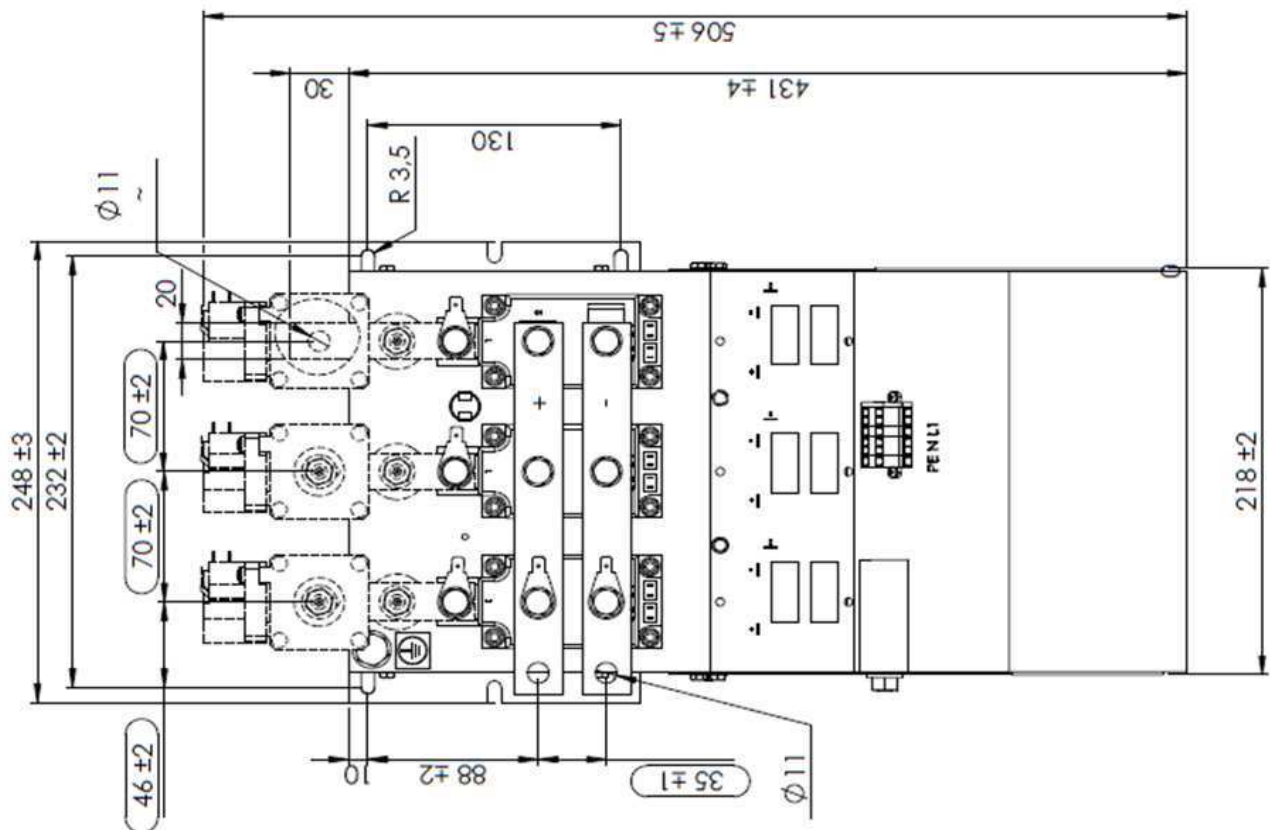
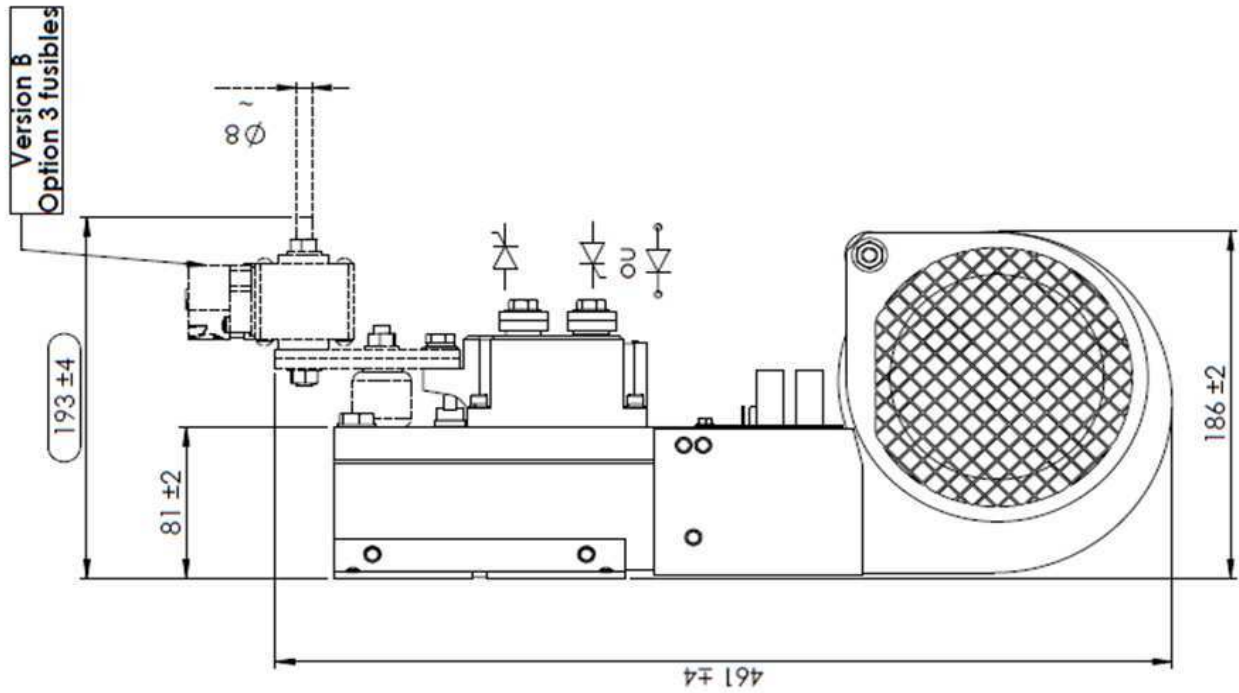

Dimensions

This technical information specifies semiconductor devices but promises no characteristics. No warranty or guarantee expressed or implied is made regarding delivery, performance or suitability.