



## CAL-DIODE

$I_F = 50 \text{ A}$

$V_{RRM} = 600 \text{ V}$

Size: 5,6 mm x 5,6 mm

### SKCD 31 C 060 I3

#### Features

- low forward voltage drop combined with a low temperature dependence
- easy paralleling due to a small forward voltage spread
- very soft recovery behavior
- small switching losses
- high ruggedness
- compatible to thick wire bonding
- compatible to all standard solder processes

#### Typical Applications\*

- freewheeling diode for IGBT

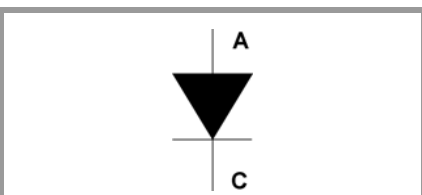

SKCD

Absolute Maximum Ratings			
Symbol	Conditions	Values	Unit
$V_{RRM}$	$T_j = 25 \text{ }^\circ\text{C}$ , $I_R = 0.1 \text{ mA}$	600	V
$I_{F(AV)}$	$T_s = 80 \text{ }^\circ\text{C}$ , $T_j = 150 \text{ }^\circ\text{C}$	40	A
$I_{FSM}$	10 ms	$T_j = 25 \text{ }^\circ\text{C}$	A
	sin 180°	$T_j = 150 \text{ }^\circ\text{C}$	440
$T_{jmax}$		150	°C

Electrical Characteristics					
Symbol	Conditions	min.	typ.	max.	Unit
$i^2t$	$T_j = 150 \text{ }^\circ\text{C}$ , 10 ms, sin 180°			968	A <sup>2</sup> s
$I_R$	$T_j = 25 \text{ }^\circ\text{C}$ , $V_{RRM} = 600 \text{ V}$			0.10	mA
	$T_j = 125 \text{ }^\circ\text{C}$ , $V_{RRM} = 600 \text{ V}$			4.00	mA
$V_F$	$T_j = 25 \text{ }^\circ\text{C}$ , $I_F = 50 \text{ A}$		1.35	1.60	V
	$T_j = 125 \text{ }^\circ\text{C}$ , $I_F = 50 \text{ A}$		1.35	1.60	V
$V_{(TO)}$	$T_j = 125 \text{ }^\circ\text{C}$		0.90		V
$r_T$	$T_j = 125 \text{ }^\circ\text{C}$		8.3		mΩ

Dynamic Characteristics					
Symbol	Conditions	min.	typ.	max.	Unit
$t_{rr}$	$T_j = 25 \text{ }^\circ\text{C}$ , 50 A, 300 V, 800 A/μs				μs
$t_{rr}$	$T_j = 125 \text{ }^\circ\text{C}$ , 50 A, 300 V, 800 A/μs				ns
$Q_{rr}$	$T_j = 25 \text{ }^\circ\text{C}$ , 50 A, 300 V, 800 A/μs				μC
$Q_{rr}$	$T_j = 125 \text{ }^\circ\text{C}$ , 50 A, 300 V, 800 A/μs		3.3		μC
$I_{rrm}$	$T_j = 25 \text{ }^\circ\text{C}$ , 50 A, 300 V, 800 A/μs				A
	$T_j = 125 \text{ }^\circ\text{C}$ , 50 A, 300 V, 800 A/μs		30		A

Thermal Characteristics					
Symbol	Conditions	min.	typ.	max.	Unit
$T_j$		-40		150	°C
$T_{stg}$		-40		150	°C
$T_{solder}$	10 min.			250	°C
$T_{solder}$	5 min.			320	°C
$R_{th(j-s)}$	sold. on 0,38 mm DCB, reference point on copper heatsink close to the chip		1		K/W

Mechanical Characteristics			
Symbol	Conditions	Values	Unit
Raster size		5.6 x 5.6	mm <sup>2</sup>
Area total		31.36	mm <sup>2</sup>
Anode		bondable (Al)	
Cathode		solderable (Ag/Ni)	
Wire bond		Al, diameter ≤ 500 μm	
Package		wafer frame	
Chips / Package		314 (5" Wafer)	pcs

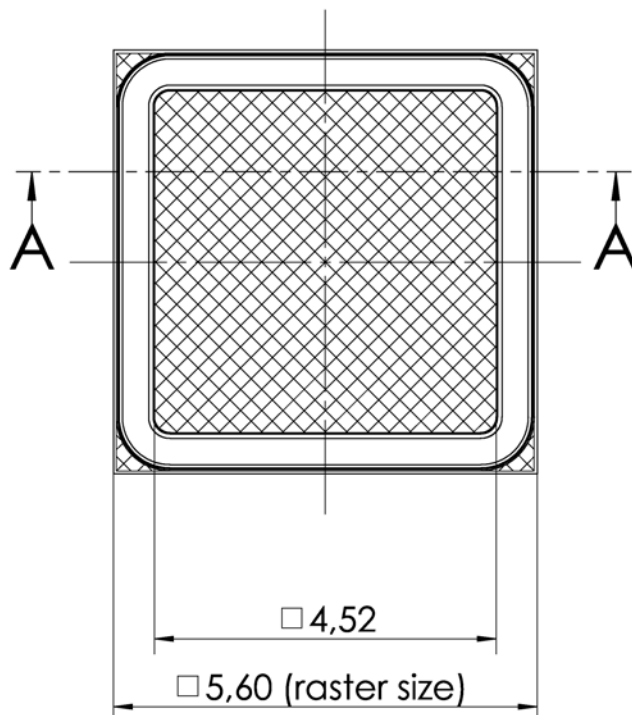
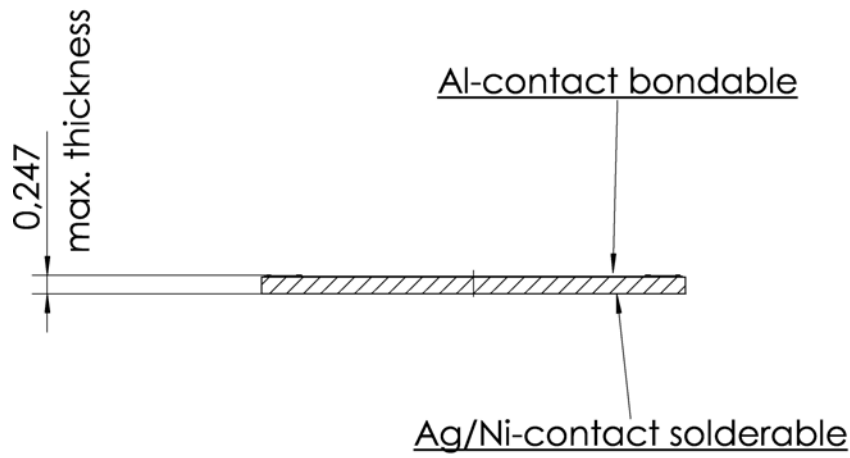

die size after cutting  
□ 5,57 mm

This is an electrostatic discharge sensitive device (ESDS), international standard IEC 60747-1, Chapter IX

\* The specifications of our components may not be considered as an assurance of component characteristics. Components have to be tested for the respective application. Adjustments may be necessary. The use of SEMIKRON products in life support appliances and systems is subject to prior specification and written approval by SEMIKRON. We therefore strongly recommend prior consultation of our personal.