

SKET 740/22G H4

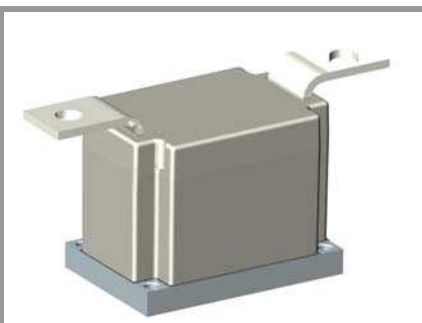

SEMIPACK® 6

Thyristor Modules

SKET 740/22G H4

Features

- Precious metal pressure contacts for high reliability
- Thyristor with amplifying gate
- UL recognized, file no. E 63 532

Typical Applications*

- DC motor control (e. g. for machine tools)
- Temperature control (e. g. for ovens, chemical processes)
- Softstart application

Footnotes

¹⁾ T_{jmax} up to 130°C is allowable for overload conditions, max. time period for the overload condition is 20s

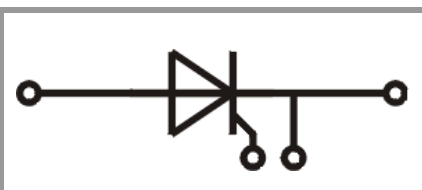

SKET

Absolute Maximum Ratings				
Symbol	Conditions		Values	Unit
Chip				
$I_{T(AV)}$	sinus 180°	$T_c = 85\text{ °C}$	699	A
		$T_c = 100\text{ °C}$	489	A
I_{TSM}	10 ms	$T_j = 25\text{ °C}$	36000	A
		$T_j = 125\text{ °C}$	31000	A
i^2t	10 ms	$T_j = 25\text{ °C}$	6480000	A ² s
		$T_j = 125\text{ °C}$	4805000	A ² s
V_{RSM}			2300	V
V_{RRM}			2200	V
V_{DRM}			2200	V
$(di/dt)_{cr}$	$T_j = 125\text{ °C}$		200	A/μs
$(dv/dt)_{cr}$	$T_j = 125\text{ °C}$		2000	V/μs
T_j	¹⁾		-40 ... 125	°C
Module				
T_{stg}			-40 ... 125	°C
V_{isol}	a.c.; 50 Hz; r.m.s.	1 min	4000	V
		1 s	4800	V

Characteristics						
Symbol	Conditions		min.	typ.	max.	Unit
Chip						
V_T	$T_j = 25\text{ °C}$	$I_T = 3000\text{ A}$		1.55	1.65	V
$V_{T(TO)}$	$T_j = 125\text{ °C}$			0.82	0.88	V
r_T	$T_j = 125\text{ °C}$			0.25	0.28	mΩ
$I_{DD}; I_{RD}$	$T_j = 125\text{ °C}$	$V_{DD} = V_{DRM}; V_{RD} = V_{RRM}$			150	mA
t_{gd}	$T_j = 25\text{ °C}$	$I_G = 1\text{ A}, di_G/dt = 1\text{ A}/\mu\text{s}$		1		μs
t_{gr}		$V_D = 0.67 * V_{DRM}$		2		μs
t_q	$T_j = 125\text{ °C}$			200		μs
I_H	$T_j = 25\text{ °C}$			1000	2000	mA
I_L	$T_j = 25\text{ °C}$	$R_G = 33\text{ }\Omega$		1500	2500	mA
V_{GT}	$T_j = 25\text{ °C}$	d.c.	3			V
I_{GT}	$T_j = 25\text{ °C}$	d.c.	300			mA
V_{GD}	$T_j = 125\text{ °C}$	d.c.			0.25	V
I_{GD}	$T_j = 125\text{ °C}$	d.c.			10	mA
$R_{th(j-c)}$	continuous DC	per chip			0.0405	K/W
		per module			0.0405	K/W
$R_{th(j-c)}$	sin. 180°	per chip			0.042	K/W
		per module			0.042	K/W
$R_{th(j-c)}$	rec. 120°	per chip			0.043	K/W
		per module			0.043	K/W
Module						
$R_{th(c-s)}$	chip				0.01	K/W
	module				0.01	K/W
M_s	to heatsink M6		5.1		6.9	Nm
M_t	to terminal M12		15.3		20.7	Nm
a					5 * 9,81	m/s ²
w				2150		g

SKET 740/22G H4

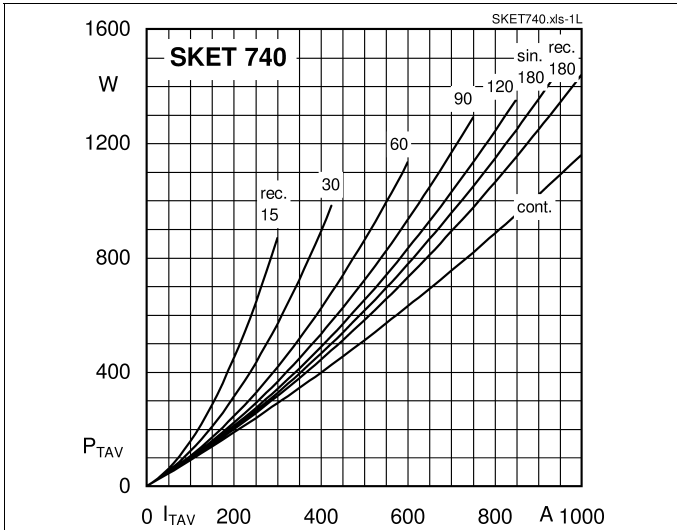

Fig. 1L: Power dissipation per thyristor vs. on-state current

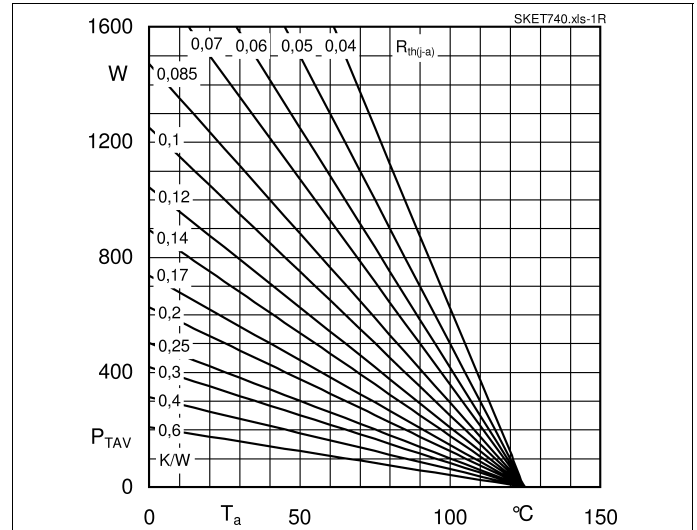

Fig. 1R: Power dissipation per thyristor vs. ambient temperature

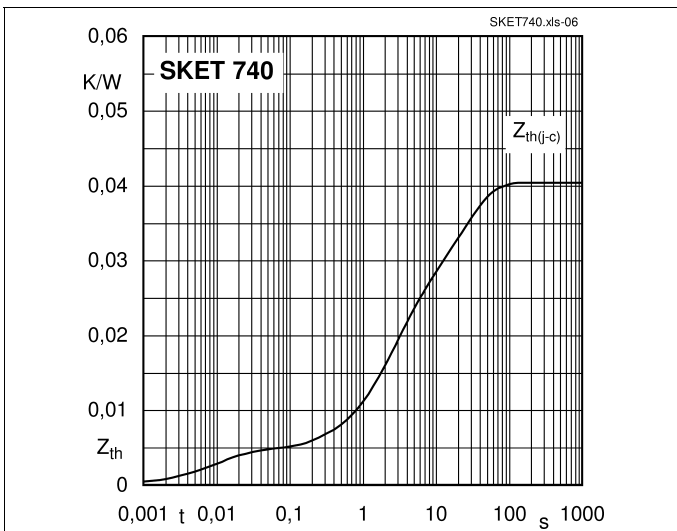

Fig. 6: Transient thermal impedance vs. time

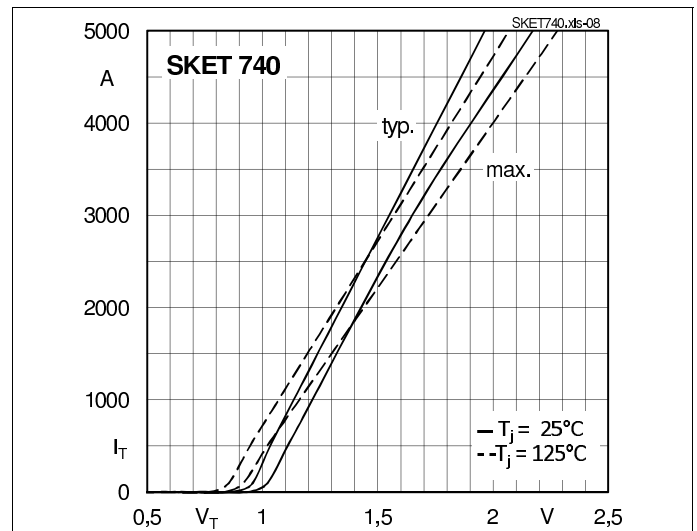

Fig. 7: On-state characteristics

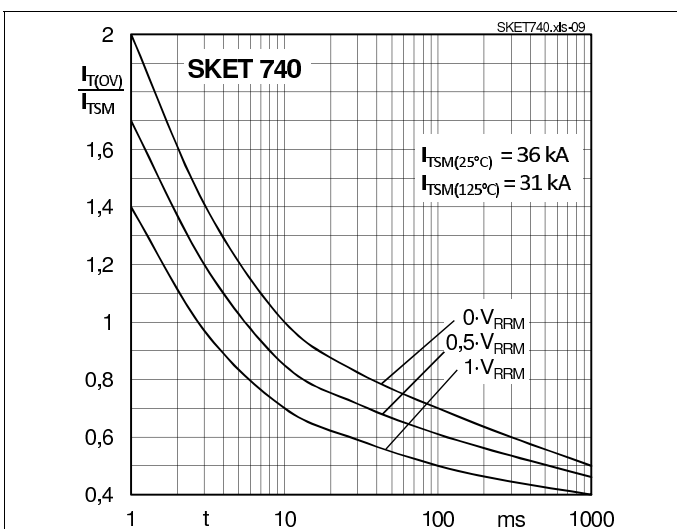

Fig. 8: Surge overload current vs. time

SKET 740/22G H4

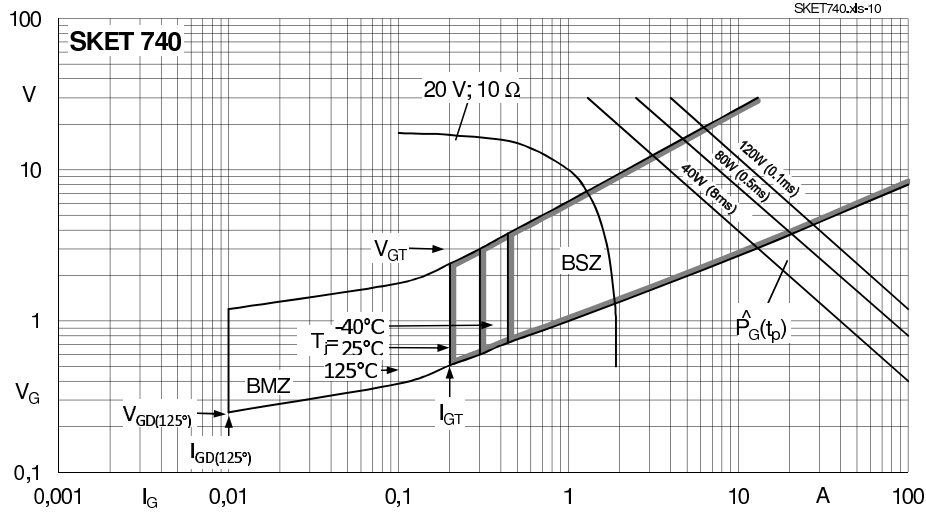
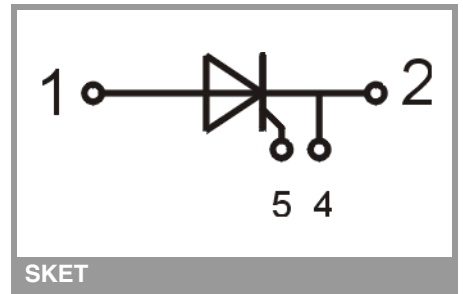
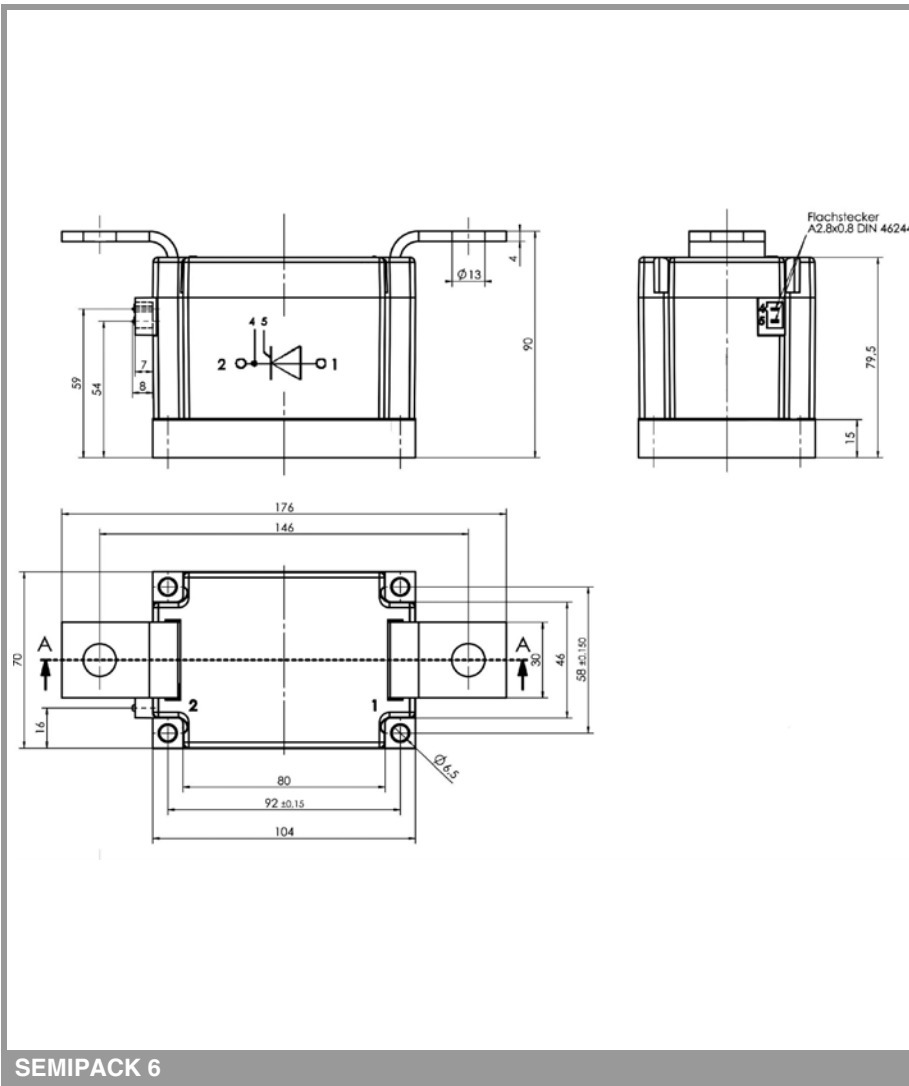

Fig. 9: Gate trigger characteristics



This is an electrostatic discharge sensitive device (ESDS), international standard IEC 60747-1, Chapter IX

* The specifications of our components may not be considered as an assurance of component characteristics. Components have to be tested for the respective application. Adjustments may be necessary. The use of SEMIKRON products in life support appliances and systems is subject to prior specification and written approval by SEMIKRON. We therefore strongly recommend prior consultation of our staff.