

SKM 300GB126D

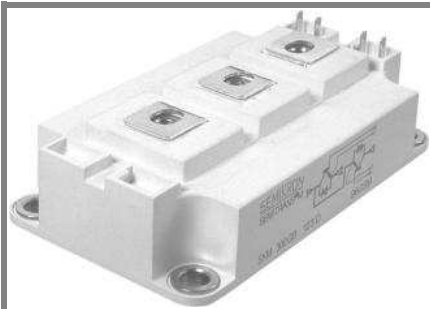

SEMITRANS® 3

Trench IGBT Module

SKM 300GB126D

Features

- Trench = Trenchgate technology
- V_{CEsat} with positive temperature coefficient
- High short circuit capability, self limiting to $6 \times I_C$

Typical Applications*

- Electronic welders
- AC inverter drives
- UPS

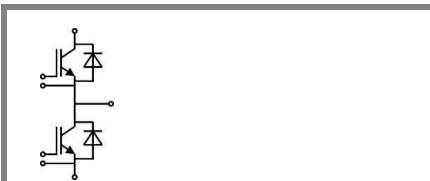

GB

Absolute Maximum Ratings		$T_c = 25\text{ °C}$, unless otherwise specified			
Symbol	Conditions	Values		Units	
IGBT					
V_{CES}	$T_j = 25\text{ °C}$	1200		V	
I_C	$T_j = 150\text{ °C}$	$T_{case} = 25\text{ °C}$	310		A
		$T_{case} = 80\text{ °C}$	200		A
I_{CRM}	$I_{CRM} = 2 \times I_{Cnom}$	400		A	
V_{GES}		± 20		V	
t_{psc}	$V_{CC} = 600\text{ V}; V_{GE} \leq 20\text{ V}; T_j = 125\text{ °C}$ $V_{CES} < 1200\text{ V}$	10		µs	
Inverse Diode					
I_F	$T_j = 150\text{ °C}$	$T_{case} = 25\text{ °C}$	250		A
		$T_{case} = 80\text{ °C}$	170		A
I_{FRM}	$I_{FRM} = 2 \times I_{Fnom}$	400		A	
Module					
$I_{t(RMS)}$		500		A	
T_{vj}		- 40 ... + 150		°C	
T_{stg}		-40...+125		°C	
V_{isol}	AC, 1 min.	4000		V	

Characteristics		$T_c = 25\text{ °C}$, unless otherwise specified				
Symbol	Conditions	min.	typ.	max.	Units	
IGBT						
$V_{GE(th)}$	$V_{GE} = V_{CE}, I_C = 8\text{ mA}$	5	5,8	6,5	V	
I_{CES}	$V_{GE} = 0\text{ V}, V_{CE} = V_{CES}$	$T_j = 25\text{ °C}$		0,1	0,3	mA
V_{CE0}		$T_j = 25\text{ °C}$		1	1,2	V
		$T_j = 125\text{ °C}$		0,9	1,1	V
r_{CE}	$V_{GE} = 15\text{ V}$	$T_j = 25\text{ °C}$		3,5	4,7	mΩ
		$T_j = 125\text{ °C}$		5,5	6,8	mΩ
$V_{CE(sat)}$	$I_{Cnom} = 200\text{ A}, V_{GE} = 15\text{ V}$	$T_j = 25\text{ °C}_{chiplev.}$		1,7	2,15	V
		$T_j = 125\text{ °C}_{chiplev.}$		2	2,45	V
C_{ies}	$V_{CE} = 25, V_{GE} = 0\text{ V}$	$f = 1\text{ MHz}$		15		nF
C_{oes}				1,2		nF
C_{res}				1,1		nF
Q_G	$V_{GE} = -8\text{ V} - +20\text{ V}$			1800		nC
R_{Gint}	$T_j = 25\text{ °C}$			3,8		Ω
$t_{d(on)}$	$R_{Gon} = 1,5\text{ Ω}$	$V_{CC} = 600\text{ V}$ $I_C = 200\text{ A}$	$T_j = 25\text{ °C}$		280	ns
t_r			$T_j = 125\text{ °C}$		37	ns
E_{on}			$V_{GE} = \pm 15\text{ V}$		21	mJ
$t_{d(off)}$	$R_{Goff} = 1,5\text{ Ω}$	$V_{GE} = \pm 15\text{ V}$	$T_j = 25\text{ °C}$		560	ns
t_f			$T_j = 125\text{ °C}$		100	ns
E_{off}					33	mJ
$R_{th(j-c)}$	per IGBT			0,12		K/W

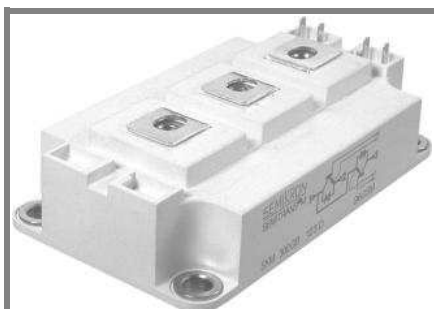

SEMITRANS® 3

Trench IGBT Module

SKM 300GB126D

Features

- Trench = Trenchgate technology
- V_{CEsat} with positive temperature coefficient
- High short circuit capability, self limiting to $6 \times I_c$

Typical Applications*

- Electronic welders
- AC inverter drives
- UPS

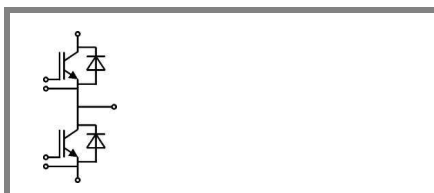

GB

Characteristics				min.	typ.	max.	Units
Symbol	Conditions						
Inverse diode							
$V_F = V_{EC}$	$I_{Fnom} = 200 \text{ A}; V_{GE} = 0 \text{ V}$	$T_j = 25 \text{ }^\circ\text{C}_{chiplev.}$			1,6	1,8	V
		$T_j = 125 \text{ }^\circ\text{C}_{chiplev.}$			1,6	1,8	V
V_{F0}		$T_j = 25 \text{ }^\circ\text{C}$			1	1,1	V
		$T_j = 125 \text{ }^\circ\text{C}$			0,8	0,9	V
r_F		$T_j = 25 \text{ }^\circ\text{C}$			3	3,5	mΩ
		$T_j = 125 \text{ }^\circ\text{C}$			4	4,5	mΩ
I_{RRM}	$I_F = 200 \text{ A}$	$T_j = 125 \text{ }^\circ\text{C}$			290		A
Q_{rr}	$di/dt = 6200 \text{ A}/\mu\text{s}$				44		μC
E_{rr}	$V_{GE} = -15 \text{ V}; V_{CC} = 600 \text{ V}$				18		mJ
$R_{th(j-c)D}$	per diode					0,25	K/W
Module							
L_{CE}					15	20	nH
$R_{CC'+EE'}$	res., terminal-chip	$T_{case} = 25 \text{ }^\circ\text{C}$			0,35		mΩ
		$T_{case} = 125 \text{ }^\circ\text{C}$			0,5		mΩ
$R_{th(c-s)}$	per module					0,038	K/W
M_s	to heat sink M6				3	5	Nm
M_t	to terminals M6				2,5	5	Nm
w						325	g

This is an electrostatic discharge sensitive device (ESDS), international standard IEC 60747-1, Chapter IX.

* The specifications of our components may not be considered as an assurance of component characteristics. Components have to be tested for the respective application. Adjustments may be necessary. The use of SEMIKRON products in life support appliances and systems is subject to prior specification and written approval by SEMIKRON. We therefore strongly recommend prior consultation of our personal.

SKM 300GB126D

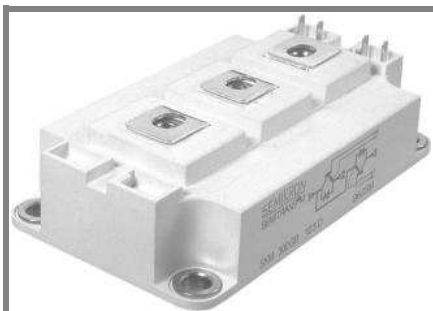

SEMITRANS® 3

Trench IGBT Module

SKM 300GB126D

Features

- Trench = Trenchgate technology
- V_{CEsat} with positive temperature coefficient
- High short circuit capability, self limiting to $6 \times I_c$

Typical Applications*

- Electronic welders
- AC inverter drives
- UPS

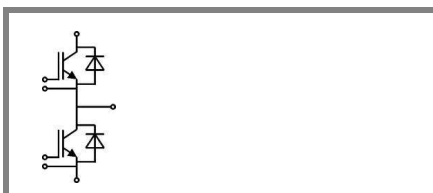

GB

Z_{th}			
Symbol	Conditions	Values	Units
$Z_{th(j-c)I}$			
$R_{\theta j-c1}$	$i = 1$	80	mk/W
$R_{\theta j-c2}$	$i = 2$	30	mk/W
$R_{\theta j-c3}$	$i = 3$	8,5	mk/W
$R_{\theta j-c4}$	$i = 4$	1,5	mk/W
τ_{i1}	$i = 1$	0,0576	s
τ_{i2}	$i = 2$	0,01	s
τ_{i3}	$i = 3$	0,002	s
τ_{i4}	$i = 4$	0,0002	s
$Z_{th(j-c)D}$			
$R_{\theta j-c1}$	$i = 1$	150	mk/W
$R_{\theta j-c2}$	$i = 2$	75	mk/W
$R_{\theta j-c3}$	$i = 3$	22	mk/W
$R_{\theta j-c4}$	$i = 4$	3	mk/W
τ_{i1}	$i = 1$	0,0331	s
τ_{i2}	$i = 2$	0,0113	s
τ_{i3}	$i = 3$	0,0012	s
τ_{i4}	$i = 4$	0,001	s

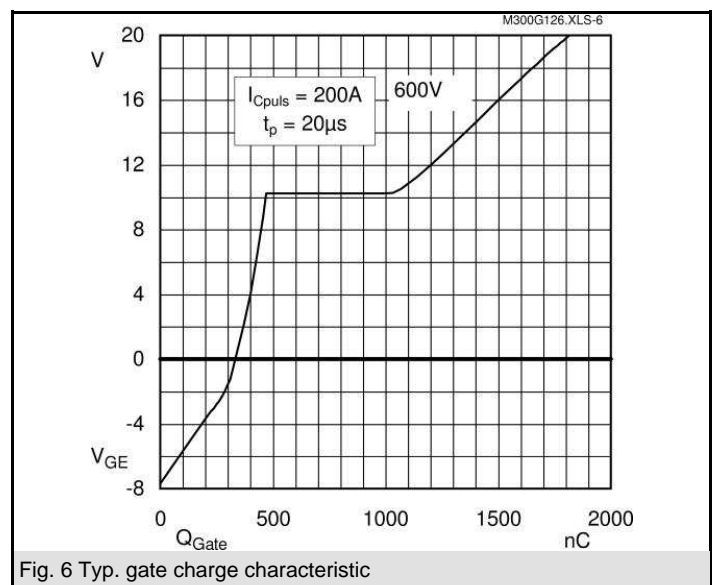
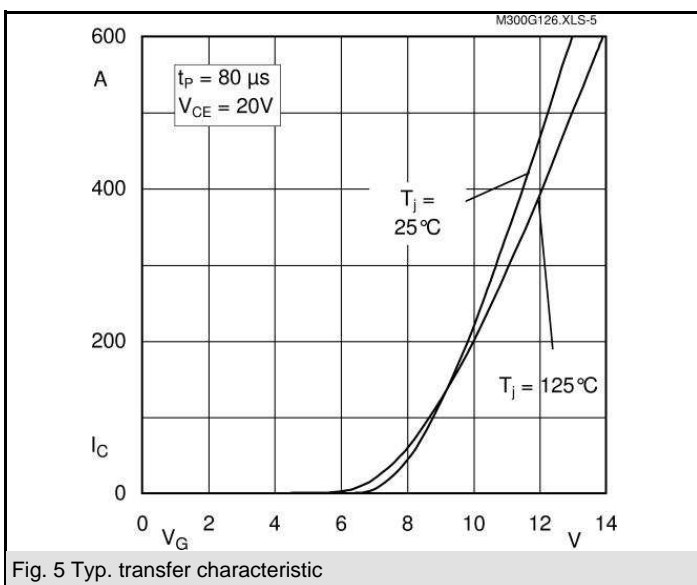
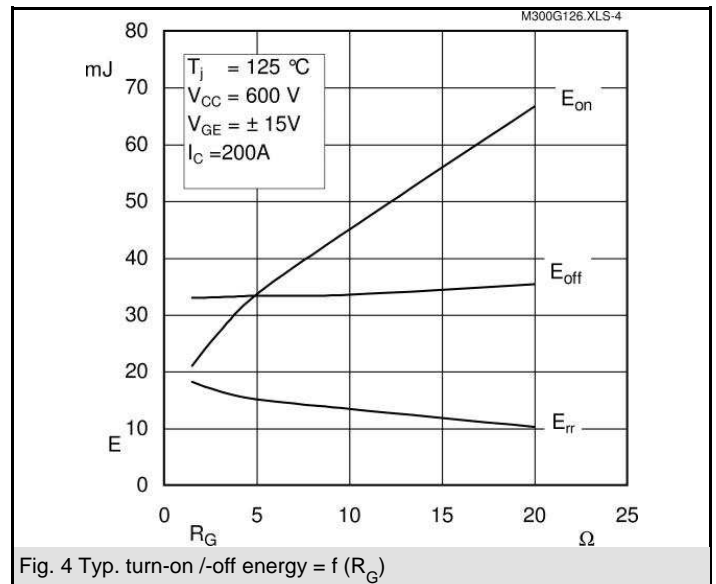
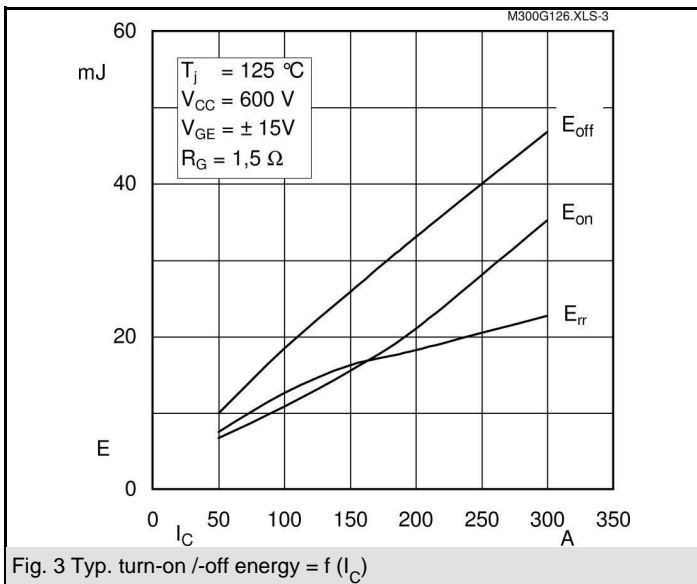
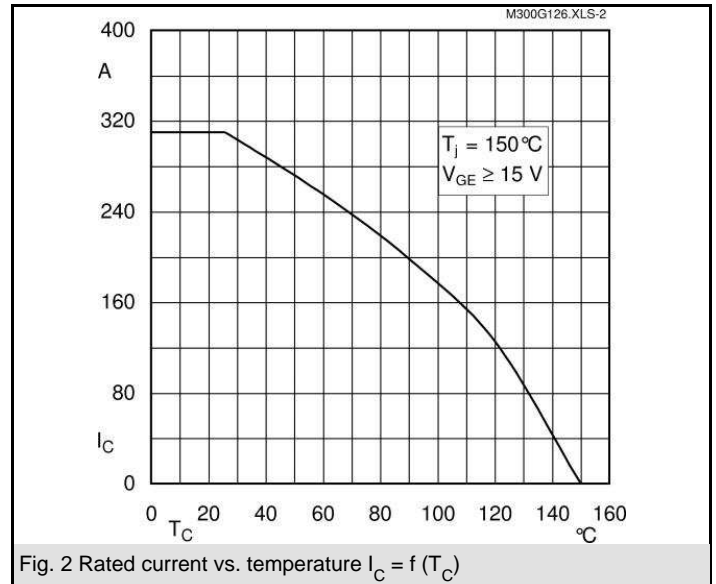
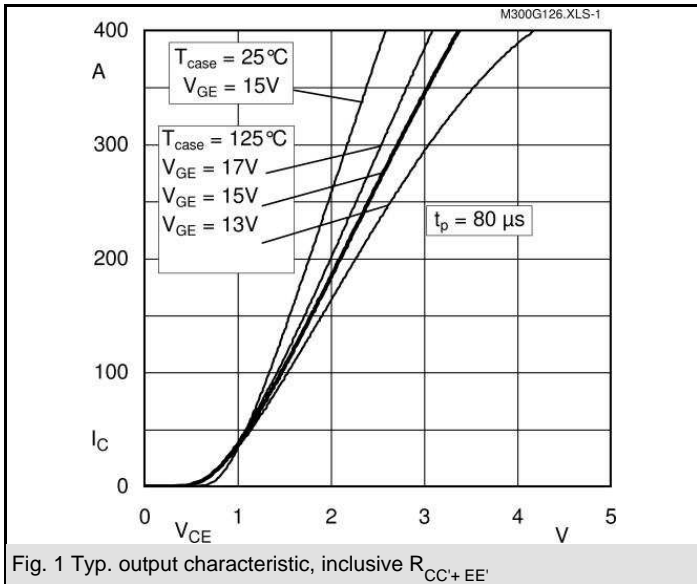

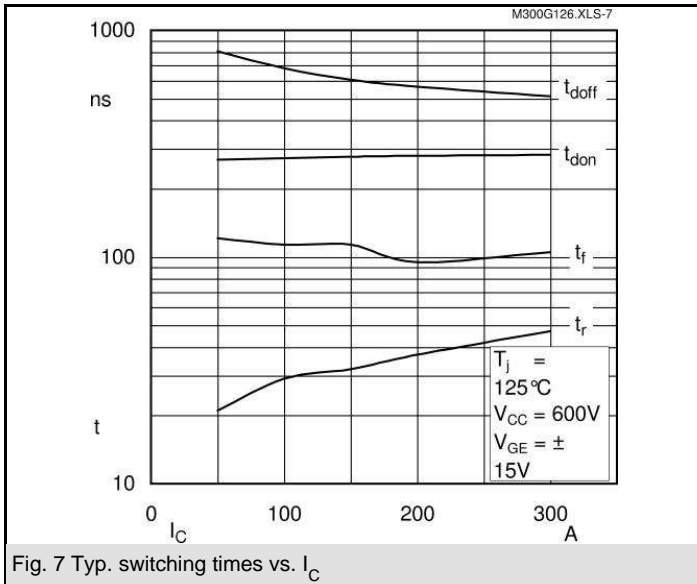

Fig. 7 Typ. switching times vs. I_C

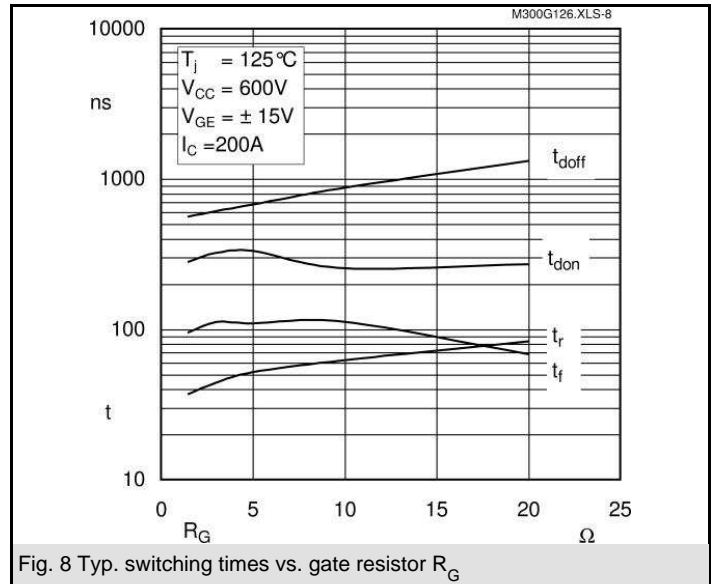

Fig. 8 Typ. switching times vs. gate resistor R_G

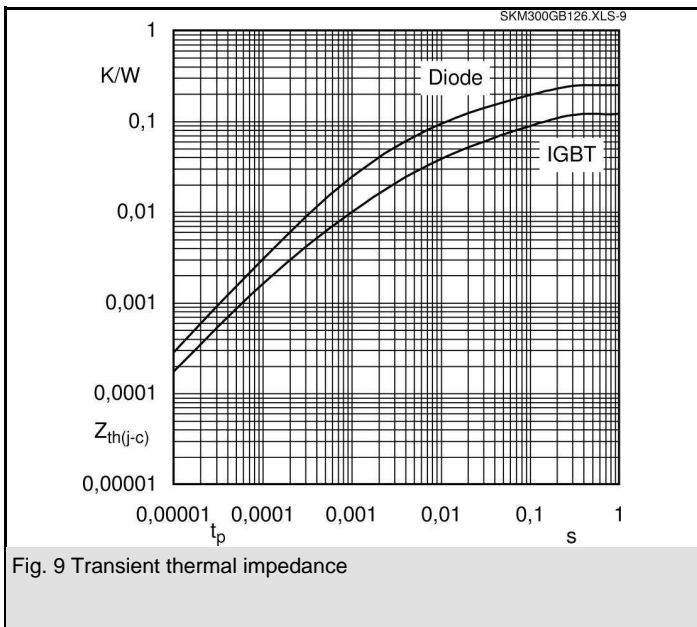

Fig. 9 Transient thermal impedance

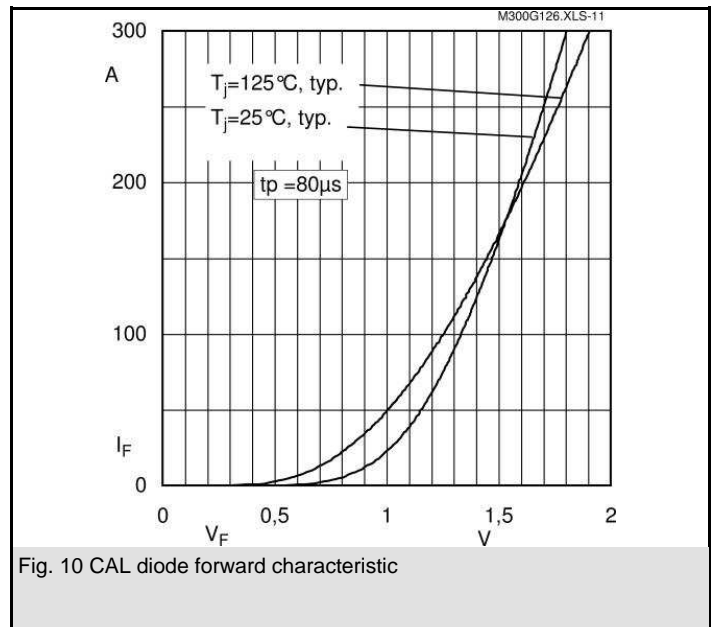

Fig. 10 CAL diode forward characteristic

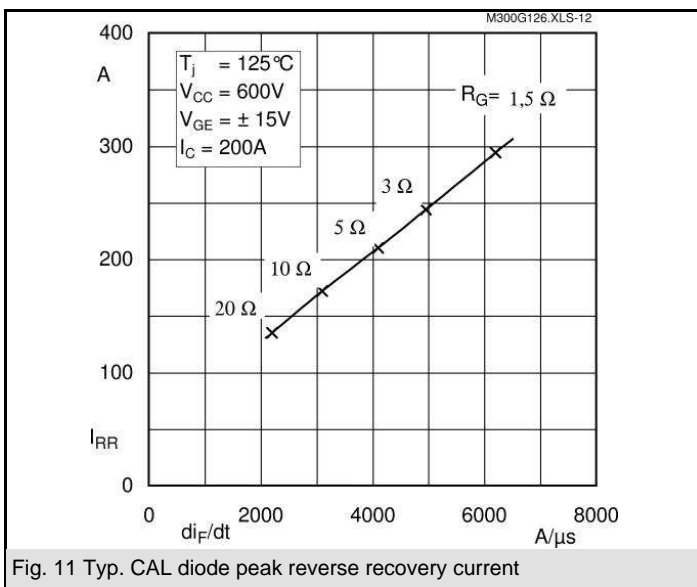

Fig. 11 Typ. CAL diode peak reverse recovery current

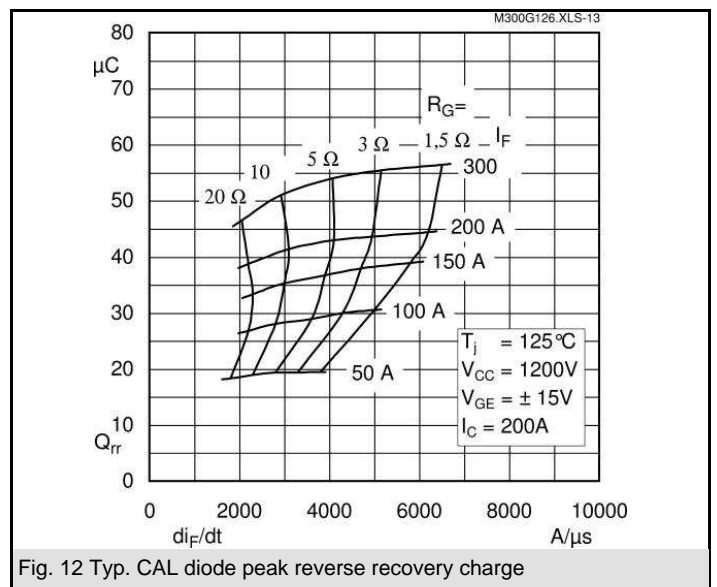

Fig. 12 Typ. CAL diode peak reverse recovery charge

SKM 300GB126D

UL Recognized

CASED56

File 63 532

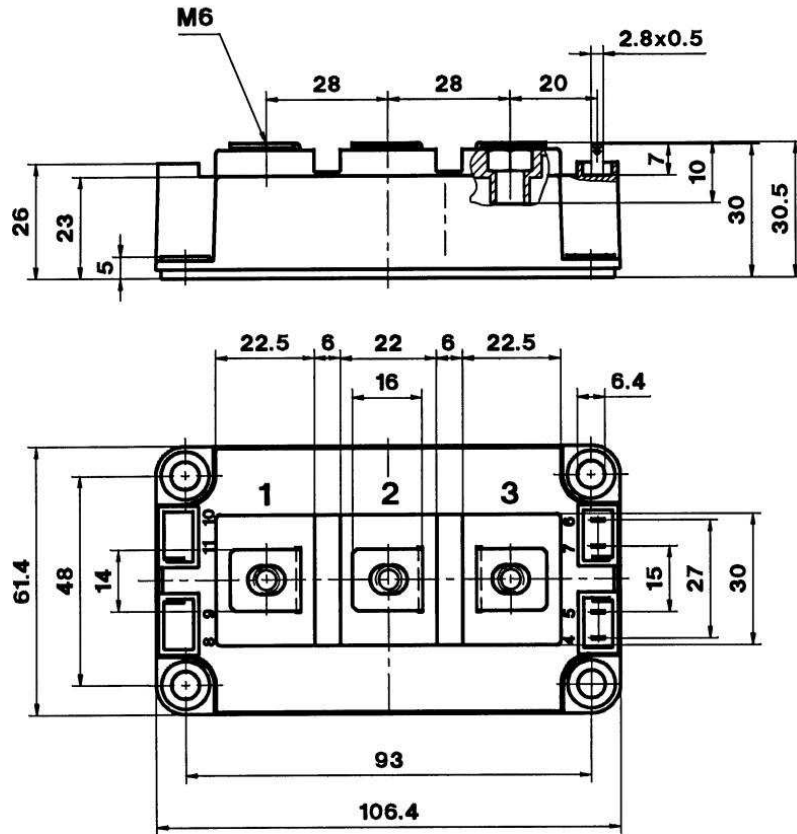

Case D 56

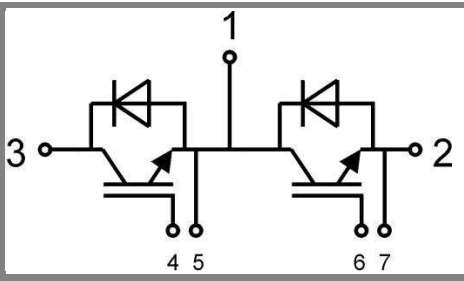

GB

Case D 56