

## 600 W Surface Mount Transient Voltage Suppressor

<p><b>DO-214AA (SMB)</b></p> 	<p>Peak Pulse Power Rating At 1 ms. Exp. 600 W</p>	<p>Reverse stand-off Voltage 5.0 ÷ 188 V</p>	
			
	<p><b>FEATURES</b></p> <ul style="list-style-type: none"> <li>• Low profile package</li> <li>• Ideal for automated placement</li> <li>• Top-Glass Technology</li> <li>• 600 W peak pulse power capability with a 10/1000 <math>\mu</math>s waveform, repetitive rate (duty cycle): 0.01 %</li> <li>• Excellent clamping capability</li> <li>• Very fast response time</li> <li>• Low incremental surge resistance</li> <li>• Available in uni-directional and bi-directional</li> <li>• Solder dip 260°C, 10s</li> <li>• AEC-Q101 qualified</li> <li>• Component in accordance to RoHS 2011/65/EU and WEEE 2002/96/EC</li> <li>• Meets MSL level 1, per J-STD-020, LF maximum peak of 260° C</li> </ul>		   <b>RoHS COMPLIANT</b>
	<p><b>MECHANICAL DATA</b></p> <ul style="list-style-type: none"> <li>• <b>Case:</b> DO-214AA (SMB). Epoxy meets UL 94V-0 flammability rating.</li> <li>• <b>Polarity:</b> For unidirectional types color band denotes cathode end. No marking on bidirectional types.</li> <li>• <b>Terminals:</b> Matte tin plated leads, solderable per MIL-STD-750 Method 2026, J-STD-002 and JESD22-B102. Consumer grade, meets JESD 201 class 1A whisker test.</li> <li>• <b>HE3 suffix</b> for high reliability grade, meets JESD 201 class 2 whisker test.</li> </ul>		
<p><b>TYPICAL APPLICATIONS</b></p> <p>Used in sensitive electronics protection against voltage transients induced by inductive load switching and lighting on ICs, MOSFET, signal lines of sensor units for consumer, computer, industrial, automotive and telecommunication.</p>			

### Maximun Ratings and Electrical Characteristics at 25°C

$P_{PPM}$	Peak Pulse Power Dissipation with 10/1000 $\mu$ s exponential pulse	600 W
$I_{FSM}$	Peak Forward Surge Current 8.3 ms. (Jedec Method) <small>(Note 1) (Note 2)</small>	100 A
$V_F$	Max. forward voltage drop at $I_F = 50$ A <small>(Note 1)</small>	3.5 V
$T_J - T_{STG}$	Operating Junction and Storage Temperature Range	- 65 to + 175 °C

Notes: 1. Valid only for Unidirectional.  
2. Mounted on 0.31 x 0.31" (8.0 x 8.0 mm) copper pads to each terminal

## 600 W Surface Mount Transient Voltage Suppressor

### Ordering information

PREFERRED P/N	PACKAGE CODE	DELIVERY MODE	BASE QUANTITY	UNIT WEIGHT (g)
SMBJ33A TRTB	TRTB	13" diameter tape and reel	3,200	0.082
SMBJ33A HE3 TRTB	TRTB	13" diameter tape and reel	3,200	0.082

### Package Outline Dimensions: (mm) DO-214AA (SMB)

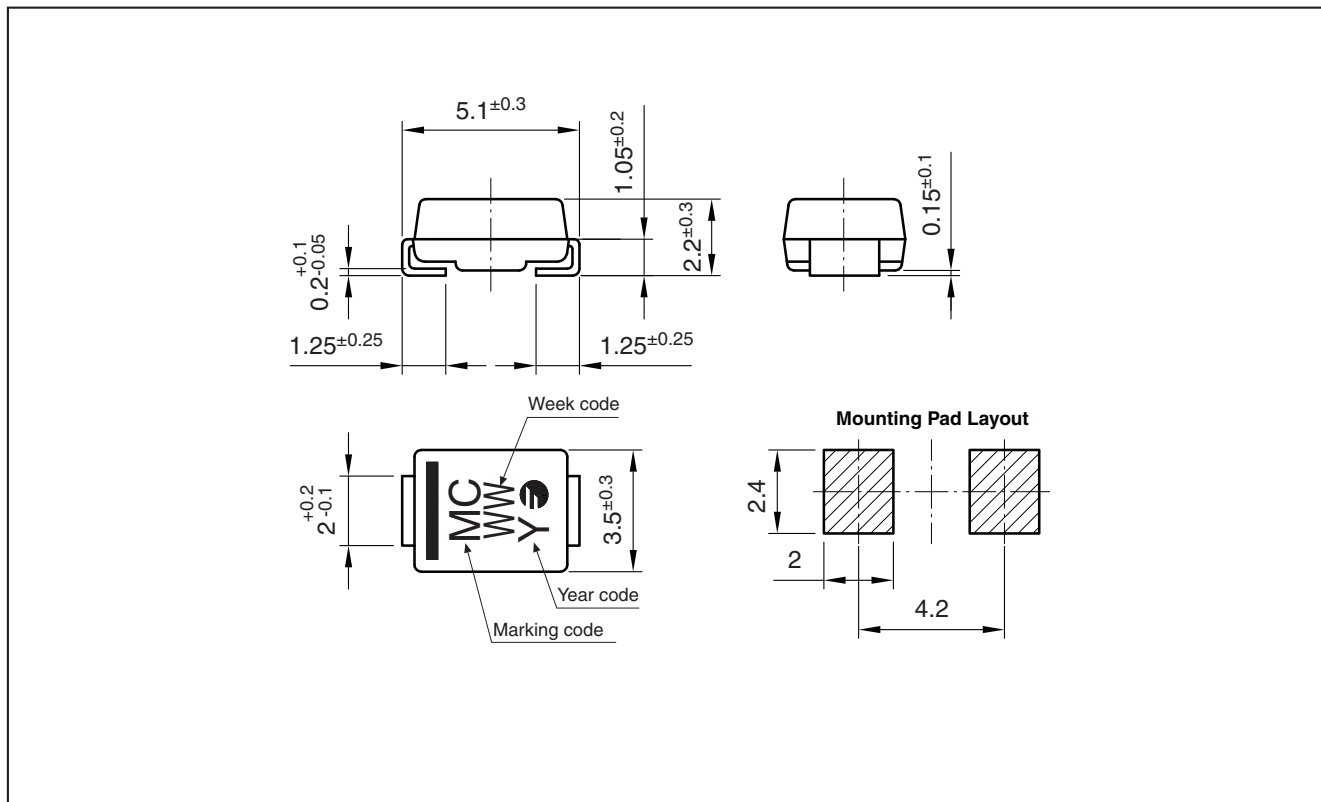

## 600 W Surface Mount Transient Voltage Suppressor

Types				Maximum Reverse Leakage Current <sup>(2)</sup>		Breakdown Voltage <sup>(1)</sup>			Max. Clamping Voltage V <sub>CL</sub> at I <sub>pp</sub> 1ms. Expo.	
				I <sub>RM</sub> (μA)	at V <sub>RM</sub> (V)	V <sub>BR</sub> (V) Min.	Max.	I <sub>R</sub> (mA)	(V)	(A)
Unidirectional	Mark	Bidirectional	Mark							
SMBJ5.0A	JF	SMBJ5.0CA	OK	800	5.0	6.40	7.07	10	9.2	65.2
SMBJ6.0A	JK	SMBJ6.0CA	OL	800	6.0	6.67	7.37	10	10.3	58.3
SMBJ6.5A	JL	SMBJ6.5CA	OM	500	6.5	7.22	7.98	10	11.2	53.6
SMBJ8.5A	JM	SMBJ8.5CA	ON	20	8.5	9.44	10.4	1	14.4	41.7
SMBJ10A	JN	SMBJ10CA	OO	5	10	11.1	12.3	1	17	35.3
SMBJ12A	JO	SMBJ12CA	OP	5	12	13.3	14.7	1	19.9	30.2
SMBJ13A	JP	SMBJ13CA	OR	1	13	14.4	15.9	1	21.5	27.9
SMBJ15A	JR	SMBJ15CA	OS	1	15	16.7	18.5	1	24.4	24.6
SMBJ18A	JS	SMBJ18CA	OT	1	18	20	22.1	1	29.2	20.5
SMBJ20A	JT	SMBJ20CA	OU	1	20	22.2	24.5	1	32.4	18.5
SMBJ22A	JU	SMBJ22CA	OV	1	22	24.4	26.9	1	35.5	16.9
SMBJ24A	JV	SMBJ24CA	OW	1	24	26.7	29.5	1	38.9	15.4
SMBJ26A	JW	SMBJ26CA	OX	1	26	28.9	31.9	1	42.1	14.3
SMBJ28A	JX	SMBJ28CA	OY	1	28	31.1	34.4	1	45.4	13.2
SMBJ30A	JY	SMBJ30CA	OZ	1	30	33.3	36.8	1	48.4	12.4
SMBJ33A	JZ	SMBJ33CA	UL	1	33	36.7	40.6	1	53.3	11.3
SMBJ36A	KA	SMBJ36CA	UM	1	36	40	44.2	1	58.1	10.3
SMBJ40A	KB	SMBJ40CA	UN	1	40	44.4	49.1	1	64.5	9.3
SMBJ43A	KC	SMBJ43CA	UO	1	43	47.8	52.8	1	69.4	8.6
SMBJ48A	OA	SMBJ48CA	UP	1	48	53.3	58.9	1	77.4	7.8
SMBJ51A	OB	SMBJ51CA	UR	1	51	56.7	62.7	1	82.4	7.3
SMBJ58A	OC	SMBJ58CA	US	1	58	64.4	71.2	1	93.6	6.4
SMBJ70A	OD	SMBJ70CA	UT	1	70	77.8	86	1	113	5.3
SMBJ85A	OE	SMBJ85CA	UU	1	85	94.4	104	1	137	4.4
SMBJ100A	OF	SMBJ100CA	UV	1	100	111	123	1	162	3.7
SMBJ130A	OG	SMBJ130CA	UW	1	130	144	159	1	209	2.9
SMBJ154A	OH	SMBJ154CA	UX	1	154	171	189	1	246	2.4
SMBJ170A	OI	SMBJ170CA	UY	1	170	189	209	1	275	2.2
SMBJ188A	OJ	SMBJ188CA	UZ	1	188	209	231	1	328	2.0

(1) Tested with pulses.  
Pulse test: t<sub>p</sub> ≤ 50 ms; δ < 2%

(2) For bidirectional types having V<sub>RM</sub> of 10V and less, the I<sub>RM</sub> limit is doubled

**600 W Surface Mount Transient Voltage Suppressor**

**Ratings and Characteristics (Ta 25 °C unless otherwise noted)**

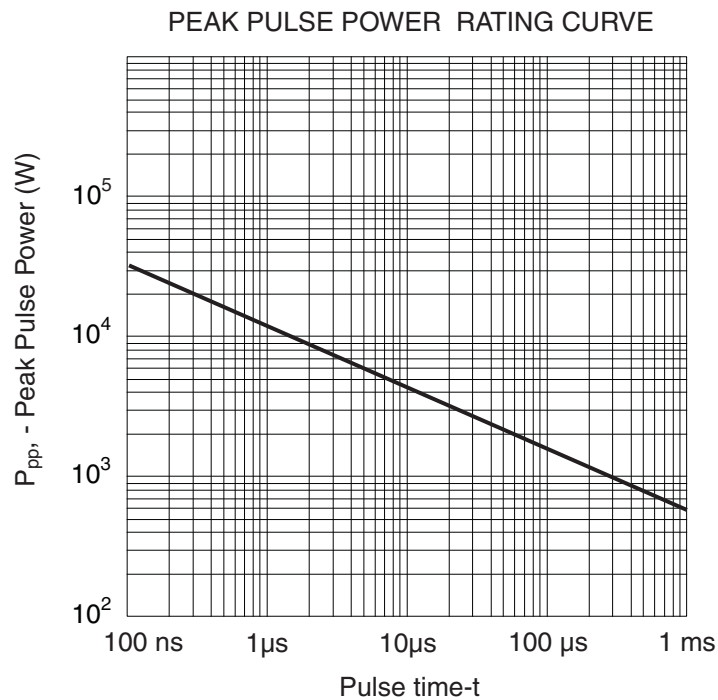
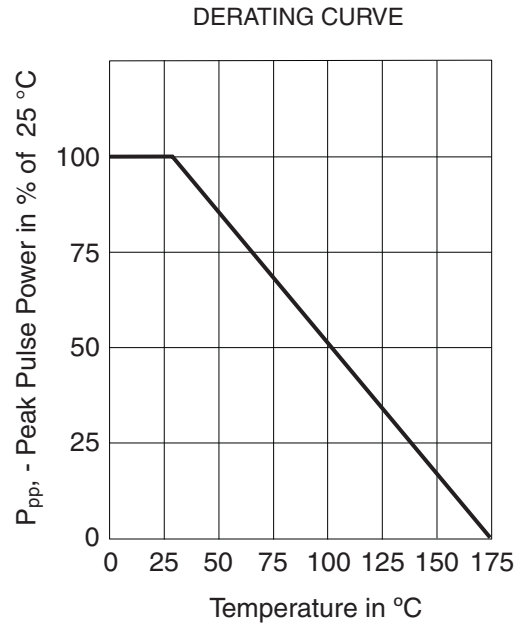
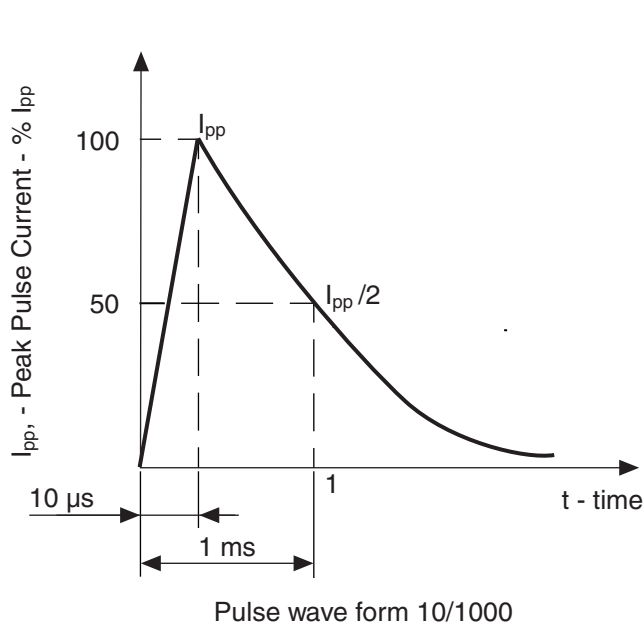

**600 W Surface Mount Transient Voltage Suppressor****Revision History**

<b>Date</b>	<b>Revision</b>	<b>Description of Changes</b>
15-Apr-2013	0	Original Data Sheet
20-Jun-2013	1	Included Max. Breakdown Voltage

**Disclaimer**

All product, product specifications and data are subject to change without notice to improve reliability, function or design or otherwise.

Fagor Electrónica, S.Coop., its affiliates, agents, and employees, and all persons acting on its or their behalf (collectively, "Fagor"), disclaim any and all liability for any errors, inaccuracies or incompleteness contained in any datasheet or in any other disclosure relating to any product.

Fagor makes no warranty, representation or guarantee regarding the suitability of the products for any particular purpose or the continuing production of any product. To the maximum extent permitted by applicable law, Fagor disclaims (i) any and all liability arising out of the application or use of any product, (ii) any and all liability, including without limitation special, consequential or incidental damages, and (iii) any and all implied warranties, including warranties of fitness for particular purpose, non-infringement and merchantability.

Statements regarding the suitability of products for certain types of applications are based on Fagor's knowledge of typical requirements that are often placed on Fagor products in generic applications. Such statements are not binding statements about the suitability of products for a particular application. It is the customer's responsibility to validate that a particular product with the properties described in the product specification is suitable for use in a particular application. Parameters provided in datasheets and/or specifications may vary in different applications and performance may vary over time. All operating parameters, including typical parameters, must be validated for each customer application by the customer's technical experts. Product specifications do not expand or otherwise modify Fagor's terms and conditions of purchase, including but not limited to the warranty expressed therein.

Except as expressly indicated in writing, Fagor products are not designed for use in medical, life-saving, or life-sustaining applications or for any other application in which the failure of the Fagor product could result in personal injury or death. Customers using or selling Fagor products not expressly indicated for use in such applications do so at their own risk and agree to fully indemnify and hold Fagor and its distributors harmless from and against any and all claims, liabilities, expenses and damages arising or resulting in connection with such use or sale, including attorneys fees, even if such claim alleges that Fagor or its distributor was negligent regarding the design or manufacture of the part. Please contact authorized Fagor personnel to obtain written terms and conditions regarding products designed for such applications.

No license, express or implied, by estoppel or otherwise, to any intellectual property rights is granted by this document or by any conduct of Fagor, Product names and markings noted herein may be trademarks of their respective owners.