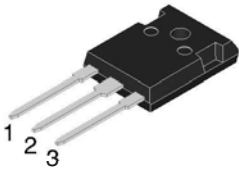
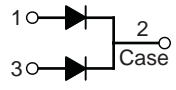

40.0 Amp. Schottky Barrier Rectifier

<p style="text-align: center; font-weight: bold; font-size: 1.2em;">TO-3P</p> <div style="text-align: center;">  </div> <div style="text-align: center; margin-top: 20px;">  <p>Common Cathode Suffix "C"</p> </div>	<table style="width: 100%; border-collapse: collapse;"> <tr> <td style="text-align: center; border-bottom: 1px solid black;">Voltage</td> <td style="text-align: center; border-bottom: 1px solid black;">Current</td> </tr> <tr> <td style="text-align: center;">45 V to 150 V</td> <td style="text-align: center;">40 A</td> </tr> </table> <ul style="list-style-type: none"> Plastic material used carries Underwriters Laboratory Classifications 94V-0 Metal silicon junction, majority carrier conduction Low power loss, high efficiency. High current capability, low forward voltage drop High surge capability For use in low voltage, high frequency inverters, free wheeling, and polarity protection applications High temperature soldering guaranteed: 260°C/10 seconds, 4.3mm from case <p>Mechanical Data</p> <ul style="list-style-type: none"> Cases: JEDEC TO-3P/TO-247AD molded plastic body Terminals: Pure tin plated, lead free. solderable per MIL-STD-750, Method 2026 Polarity: As marked Mounting position: Any Mounting torque: 10 in. - lbs. max Weight: 5.6 grams 	Voltage	Current	45 V to 150 V	40 A
Voltage	Current				
45 V to 150 V	40 A				

Absolute Maximum Ratings, according to IEC publication No. 134

		MBR 4045PT	MBR 4060PT	MBR 40100PT	MBR 40150PT
V_{RRM}	Maximum Recurrent Peak Reverse Voltage (V)	45	60	100	150
V_{RMS}	Maximum RMS Voltage (V)	31	42	70	105
V_{DC}	Maximum DC blocking voltage (V)	45	60	100	150
$I_{F(AV)}$	Maximum Average Forward Rectified Current at $T_C=125^\circ C$	40 A			
I_{FSM}	Peak Forward Surge Current, 8.3 ms Single Half Sine-wave Superimposed on Rated Load (JEDEC Method)	330 A			
I_{RRM}	Peak Repetitive Reverse Surge Current (Note 1)	2.0 A	1.0 A		
T_j	Operating Junction Temperature Range	- 65 to + 150 °C			
T_{stg}	Storage Temperature Range	- 65 to + 175 °C			

Electrical Characteristics

		MBR 4045PT	MBR 4060PT	MBR 40100PT	MBR 40150PT
V_F	Maximum Instantaneous Forward Voltage at (Note 2) $I_F = 20\text{ A}, T_C = 25^\circ C$ $I_F = 20\text{ A}, T_C = 125^\circ C$ $I_F = 40\text{ A}, T_C = 25^\circ C$ $I_F = 40\text{ A}, T_C = 125^\circ C$	0.75 V 0.65 V 0.80 V 0.75 V	0.77 V 0.67 V - -	0.84 V 0.74 V - -	0.95 V 0.92 V 1.02 V 0.98 V
I_R	Max. Instantaneous Reverse Current at Rated DC Blocking Voltage Per Leg (Note 1) @ $T_C=25^\circ C$ @ $T_C=125^\circ C$	1.0 mA		0.5 mA	
R_{thj-c}	Typical Thermal Resistance Per Leg (Note 3)	1.2 °C/W			

Notes: 1. 2.0µs Pulse Width, f=1.0 KHz
2. Pulse Test: 300µs Pulse Width, 1% Duty Cycle
3. Thermal Resistance from junction to Case Per Leg

Rating And Characteristic Curves

TYPICAL INSTANTANEOUS FORWARD CHARACTERISTICS PER LEG

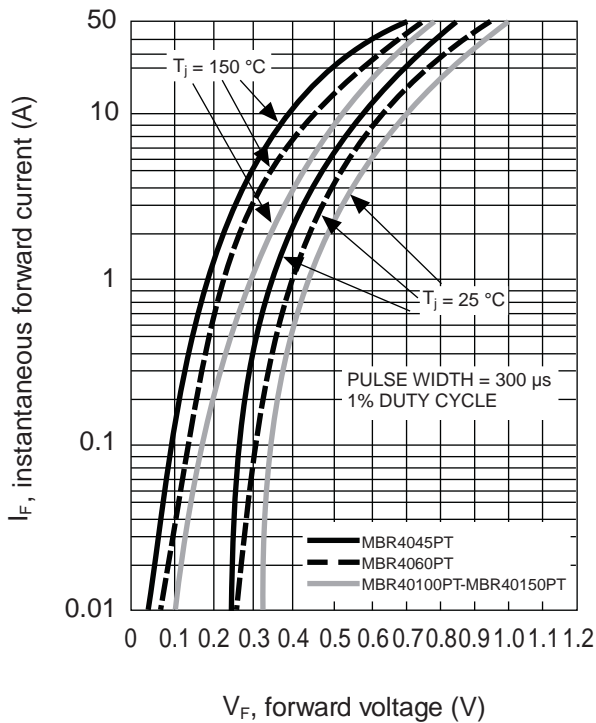

FORWARD CURRENT DERATING CURVE

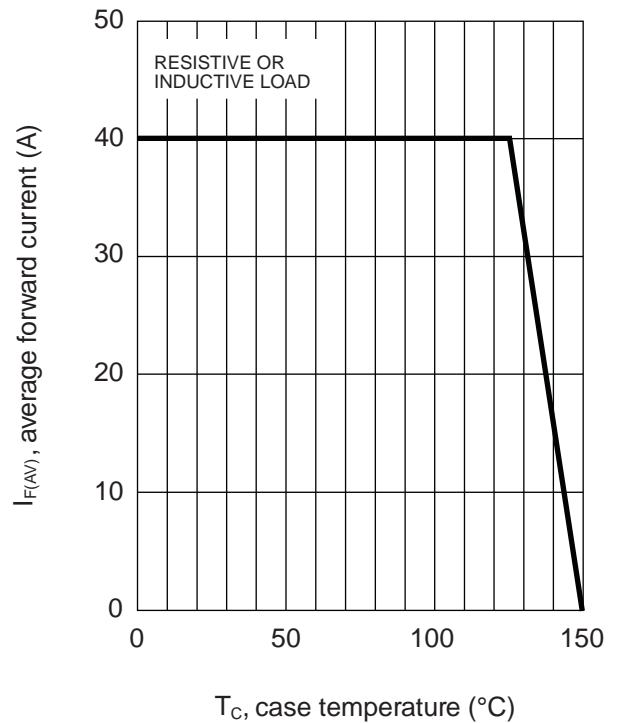

MAXIMUM NON-REPETITIVE FORWARD SURGE CURRENT PER LEG

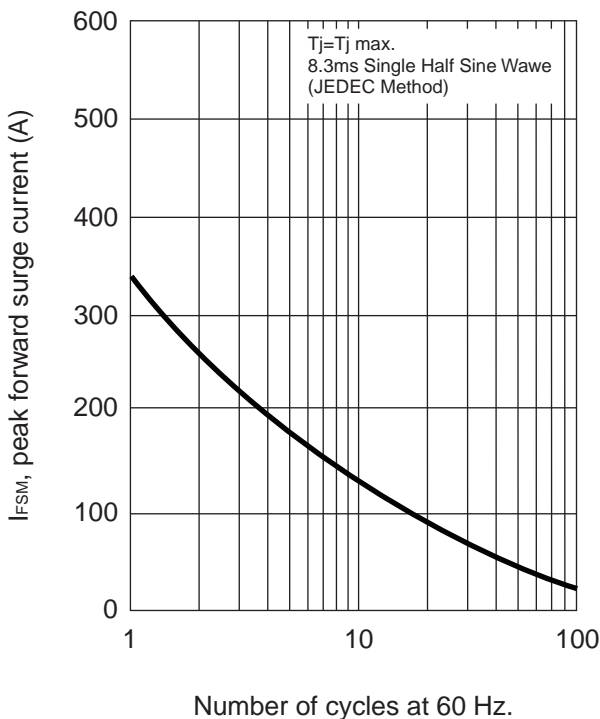

TYPICAL JUNCTION CAPACITANCE PER LEG

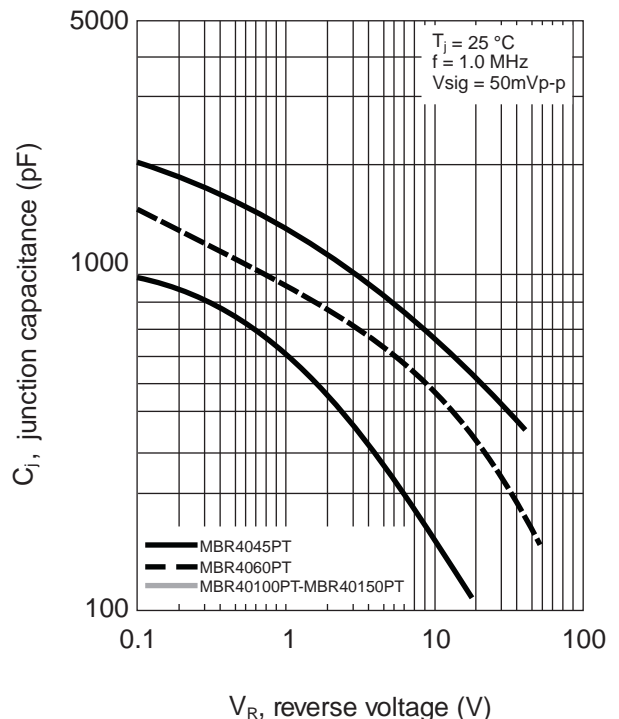

Rating And Characteristic Curves

TYPICAL REVERSE CHARACTERISTICS PER LEG

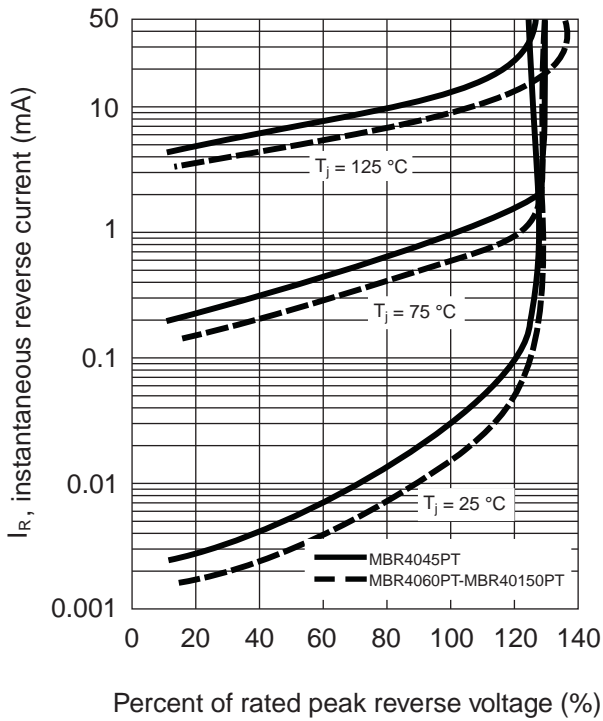

TYPICAL TRANSIENT THERMAL IMPEDANCE PER LEG

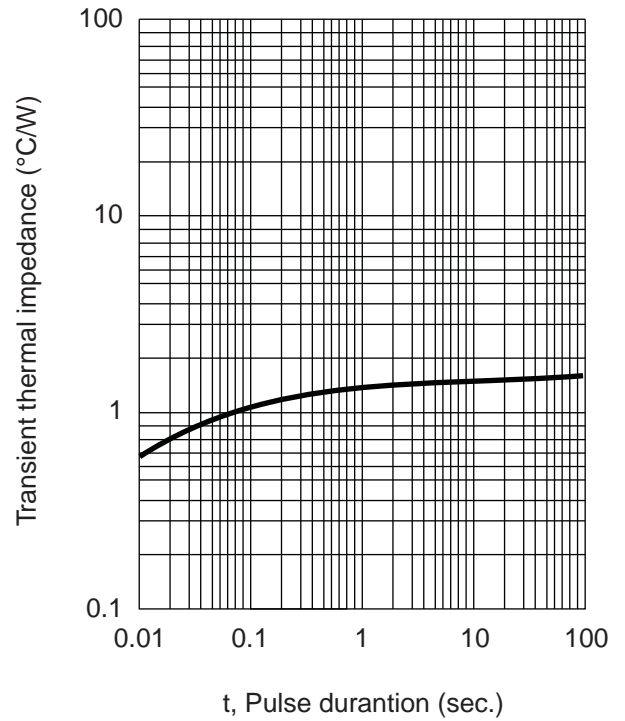

PACKAGE MECHANICAL DATA

TO-3P

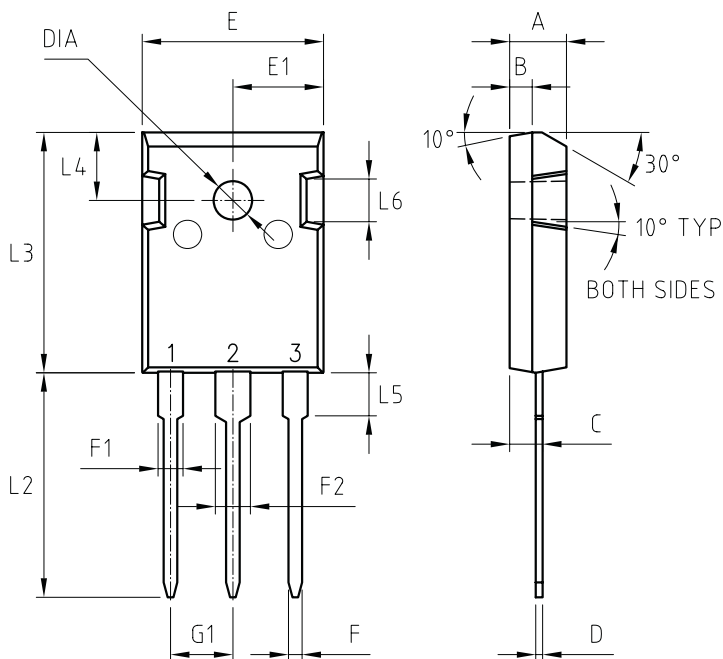

REF.	DIMENSIONS		
	Millimeters		
	Min.	Nominal	Max.
A	4.90		5.16
B		1.98	
C	2.7		3.0
D	0.51		0.76
E	15.9		16.4
E1	7.9		8.2
F	1.12		1.22
F1	1.93		2.18
F2	2.97		3.22
G1	5.2		5.7
L2	19.7		20.2
L3	20.8		21.3
L4	5.7		6.2
L5	3.5		4.1
L6		4.3	
DIA	2.9		3.4