

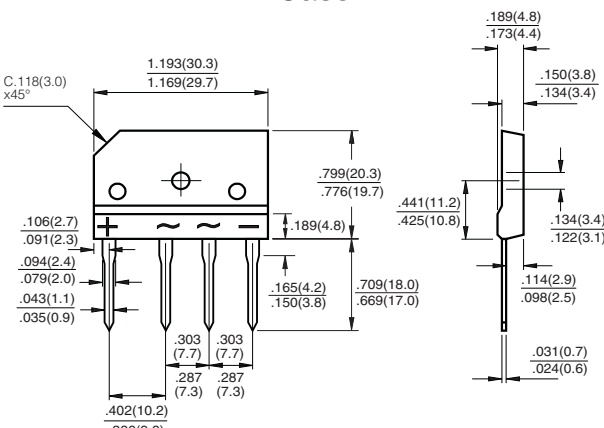

6.0 Amp. Glass Passivated Bridge Rectifier

<p style="text-align: center;">Plastic Case</p>  <ul style="list-style-type: none"> • Mounting Instructions • High temperature soldering guaranteed: 260 °C – 10 sc. • Recommended mounting torque: 0.8 N.m. 	<p>Voltage 400 to 1000 V</p> <p>Current 6.0 A</p>  <ul style="list-style-type: none"> • Glass Passivated Junction Chips. • Lead and polarity identifications. • Case: Molded Plastic. • Ideal for printed circuit board (P.C.B.). • High surge current capability. • The plastic material carries U/L recognition 94 V-O.
--	--

Maximum Ratings, according to IEC publication No. 134

		D6XB 40	D6XB 60	D6XB 80	D6XB 100
V_{RRM}	Peak recurrent reverse voltage (V)	400	600	800	1000
V_{RMS}	Maximum RMS Voltage (V)	280	420	560	700
$I_{F(AV)}$	Max. Average forward current with heatsink without heatsink	6.0 A at $T_c: 100\text{ }^\circ\text{C}$ 3.0 A at $25\text{ }^\circ\text{C}$			
I_{FSM}	8.3 ms. Peak Forward Surge Current (Jedec Method)	180 A			
V_{DIS}	Dielectric strength (terminals to case, AC 1 min.)	2500 V			
I_t^2	I_t^2 value for fusing ($t = <8.3\text{ ms}$)	120 A^2_{sec}			
T_j	Operating temperature range	-40 to +150 °C			
T_{stg}	Storage temperature range	-40 to +150 °C			

Electrical Characteristics at $T_{amb} = 25\text{ }^\circ\text{C}$

V_F	Max. forward voltage drop per diode at $I_F = 3.0\text{ A}$	1.00 V
I_R	Max. instantaneous reverse current at V_{RRM}	5 μA
$R_{th(j-c)}$	MAXIMUM THERMAL RESISTANCE Junction-case. With Heatsink.	3.4 °C/W
$R_{th(j-a)}$	Junction-Ambient. Without Heatsink.	22 °C/W

Rating And Characteristic Curves

TYPICAL FORWARD CHARACTERISTIC

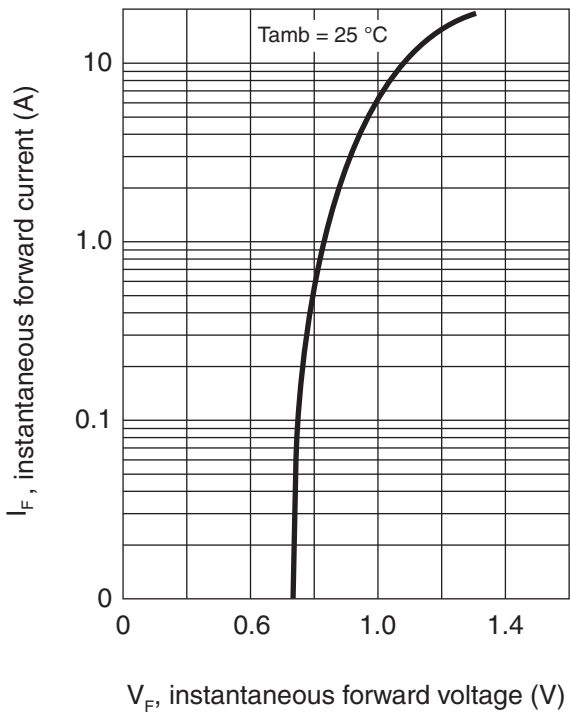

FORWARD CURRENT DERATING CURVE

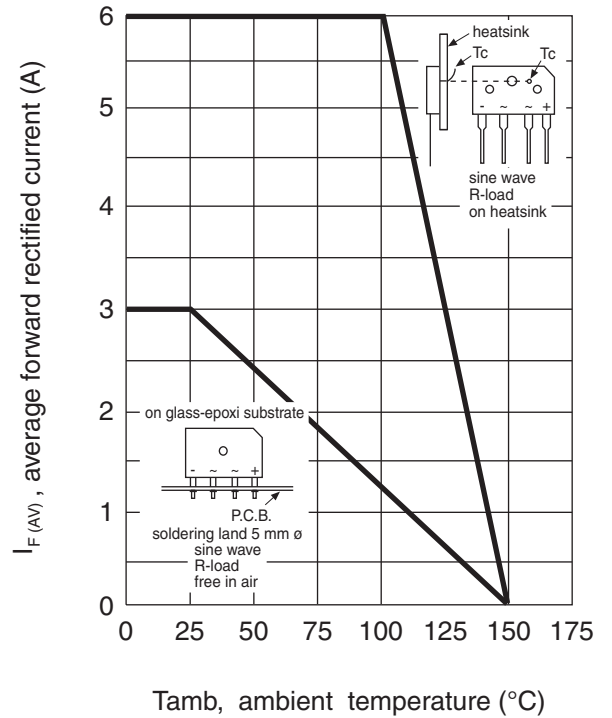

MAXIMUM NON-REPETITIVE PEAK FORWARD SURGE CURRENT

