

1N1199A ... 1N1206A, 1N3671, 1N3673, PBY271 ... PB277

Silicon-Power-Rectifiers Silizium-Leistungs-Gleichrichter

Version 2007-05-09

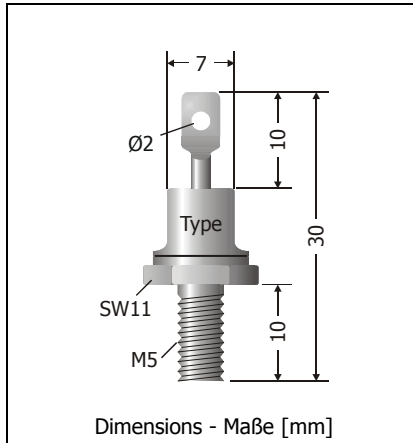

Nominal Current Nennstrom	12 A
Repetitive peak reverse voltage Periodische Spitzensperrspannung	50 ... 1000 V
Metal case Metallgehäuse	DO-4
Weight approx. – Gewicht ca.	5.5 g
Standard polarity: Cathode to stud / Kathode am Gewinde	
Index R: Anode to stud / Anode am Gewinde (e. g. 1N1199AR)	
Standard packaging: bulk	
Standard Lieferform: lose im Karton	



Maximum ratings

Grenzwerte

Type Typ	Repetive peak reverse voltage Periodische Spitzensperrspannung V_{RRM} [V]	Surge peak reverse voltage Stoßspitzensperrspannung V_{RSM} [V]
1N1199A = PBY271	50	60
1N1200A = PBY272	100	120
1N1202A = PBY273	200	240
1N1204A = PBY274	400	480
1N1206A = PBY275	600	720
1N3671 = PBY276	800	1000
1N3673 = PBY277	1000	1200

Max. average forward rectified current, R-load Dauergrenzstrom in Einwegschaltung mit R-Last	$T_C = 85^\circ\text{C}$	I_{FAV}	12 A
Repetitive peak forward current Periodischer Spitzenstrom	$f > 15\text{ Hz}$	I_{FRM}	40 A ¹⁾
Peak forward surge current, 50/60 Hz half sine-wave Stoßstrom für eine 50/60 Hz Sinus-Halbwelle	$T_A = 25^\circ\text{C}$	I_{FSM}	200/240 A
Rating for fusing, $t < 10\text{ ms}$ Grenzlastintegral, $t < 10\text{ ms}$	$T_A = 25^\circ\text{C}$	i^2t	240 A ² s
Operating junction temperature – Sperrschichttemperatur Storage temperature – Lagerungstemperatur		T_j T_s	-65...+175°C -65...+175°C

1 Max. case temperature $T_C = 85^\circ\text{C}$ – Max. Gehäusetemperatur $T_C = 85^\circ\text{C}$

Characteristics
Kennwerte

Forward Voltage – Durchlass-Spannung	$T_j = 25^\circ\text{C}$ $I_F = 30\text{ A}$	V_F	< 1.5 V
Leakage Current – Sperrstrom	$T_j = 25^\circ\text{C}$ $V_R = V_{RRM}$	I_R	< 100 μA
Thermal Resistance Junction – Case Wärmewiderstand Sperrschicht – Gehäuse		R_{thc}	< 2 K/W
Recommended mounting torque Empfohlenes Anzugsdrehmoment	10-20 UNF M 5		18 \pm 10% lb.in. 2 \pm 10% Nm

