

# D3M

Subminiature Basic Switch

## Quick-connect Terminals Simplify Wiring and Reduce Production Steps

- Easy wiring is ensured by quick-connect terminals, and horizontal layout of terminals saves mounting space.
- External actuator mounts in either of two directions to increase Switch mounting flexibility.
- Same mounting pitch as the OMRON SS Subminiature Basic Switch.

RoHS Compliant

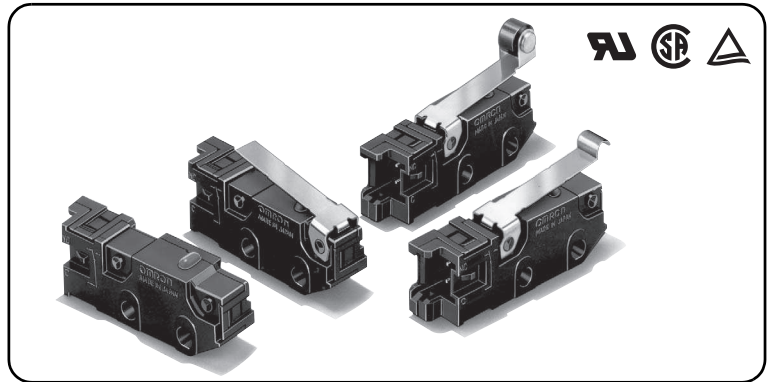

D  
3  
M

## Model Number Legend

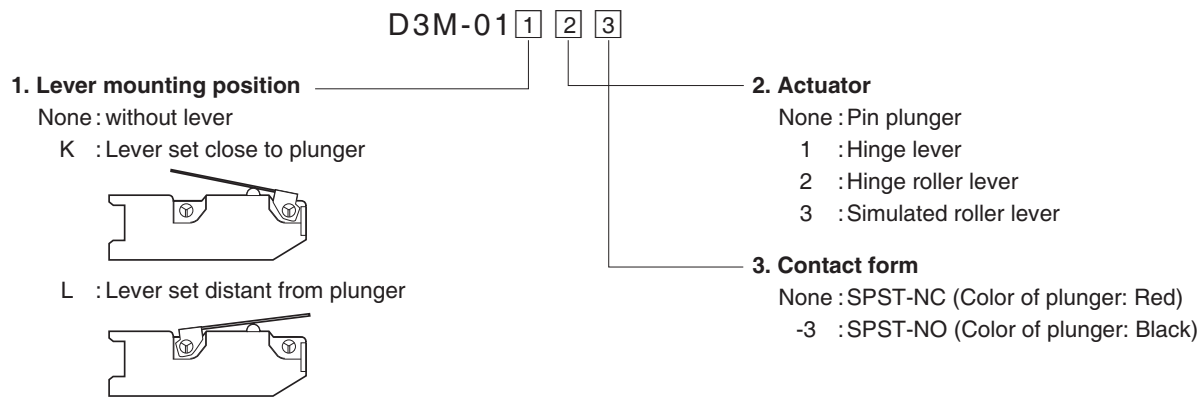

## List of Models (Contact your dealer for detailed delivery date.)

Actuator		Lever Mounting Position	Contact Form	Model
Pin plunger		-	SPST-NC	<b>D3M-01</b>
			SPST-NO	<b>D3M-01-3</b>
Hinge lever		K	SPST-NC	<b>D3M-01K1</b>
			SPST-NO	<b>D3M-01K1-3</b>
		L	SPST-NC	<b>D3M-01L1</b>
			SPST-NO	<b>D3M-01L1-3</b>
Hinge roller lever		K	SPST-NC	<b>D3M-01K2</b>
			SPST-NO	<b>D3M-01K2-3</b>
		L	SPST-NC	<b>D3M-01L2</b>
			SPST-NO	<b>D3M-01L2-3</b>
Simulated roller lever		K	SPST-NC	<b>D3M-01K3</b>
			SPST-NO	<b>D3M-01K3-3</b>
		L	SPST-NC	<b>D3M-01L3</b>
			SPST-NO	<b>D3M-01L3-3</b>

## Contact Form

● SPST-NC

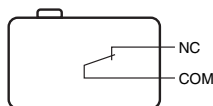

● SPST-NO

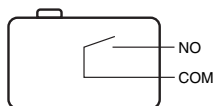

## Contact Specifications

Contact	Specification	Crossbar
	Material	Gold alloy
	Gap (standard value)	0.5 mm
Inrush current		1 A max.
Minimum applicable load (reference value)*		5 VDC 1 mA

\* Please refer to "●Using Micro Loads" in "Precautions" for more information on the minimum applicable load.

## Ratings

Rated voltage	Resistive load
30 VDC	0.1 A

Note. The above rating values apply under the following test conditions.

- (1) Ambient temperature: 20±2°C
- (2) Ambient humidity: 65±5%
- (3) Operating frequency: 30 operations/min

## Approved Safety Standards

UL (UL1054)/CSA (CSA C22.2 No.55)

Rated voltage	Model	D3M
30 VDC		0.1 A

TÜV (EN61058-1)

Rated voltage	Model	D3M
30 VDC		0.1 A

Testing conditions: 1E5 (100,000 operations) T55 (0°C to 55°C)

## Characteristics

Permissible operating speed		0.1 mm to 1 m/s (for pin plunger models)
Permissible operating frequency	Mechanical	400 operations/min
	Electrical	60 operations/min
Insulation resistance		100 MΩ min. (at 500 VDC with insulation tester)
Contact resistance (initial value) *1		100 mΩ max.
Dielectric strength	Between terminals of the same polarity	1,000 VAC 50/60 Hz for 1 min
	Between current-carrying metal parts and ground	1,500 VAC 50/60 Hz for 1 min
	Between each terminals and non-current-carrying metal parts	1,500 VAC 50/60 Hz for 1 min
Vibration resistance *2	Malfunction	10 to 55 Hz, 1.5 mm double amplitude
Shock resistance	Durability	1,000m/s <sup>2</sup> {approx. 100G} max.
	Malfunction *2	300 m/s <sup>2</sup> {approx. 30G} max.
Durability *3	Mechanical	500,000 operations min. (60 operations/min)
	Electrical	200,000 operations min. (30 operations/min)
Degree of protection		IEC IP40
Ambient operating temperature		-25°C to +85°C at ambient humidity of 60% max. (with no icing or condensation)
Ambient operating humidity		80% max. (for +5°C to +35°C)
Weight		Approx. 2g (pin plunger models)

Note. The data given above are initial values.

- \*1. Includes the resistance of the connector and lead wire (AWG #28, 50 mm length).
- \*2. The values are Free Position and Total Travel Position values for pin plunger, and Total Travel Position value for lever. Close or open circuit of the contact is 1 ms max.
- \*3. For testing conditions, consult your OMRON sales representative.

## Mounting Holes (Unit: mm)

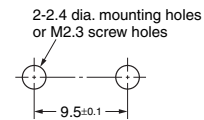

D  
3  
M

## Dimensions (Unit: mm) and Operating Characteristics

### ● Pin Plunger

D3M-01  
D3M-01-3

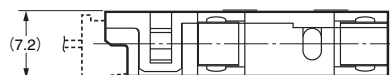

Operating Characteristics	Models	
	D3M-01	D3M-01-3
Operating Force	OF Max.	1.50 N {153 gf}
Releasing Force	RF Min.	0.25 N {25 gf}
Pretravel	PT Max.	0.6 mm
Overtravel	OT Min.	0.4 mm
Movement Differential	MD Max.	0.1 mm
Operating Position	OP	8.4±0.3 mm

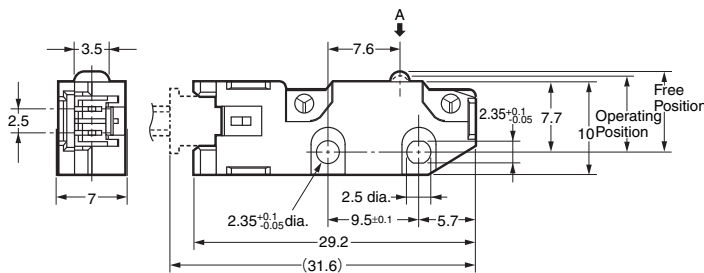
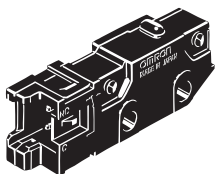

Note 1. Unless otherwise specified, a tolerance of ±0.4 mm applies to all dimensions.

Note 2. The operating characteristics are for operation in the A direction (↓).

Note 3. The terminals connect to JST's Dipole XA Connector.

## ●Hinge Lever (K position)

D3M-01K1  
D3M-01K1-3

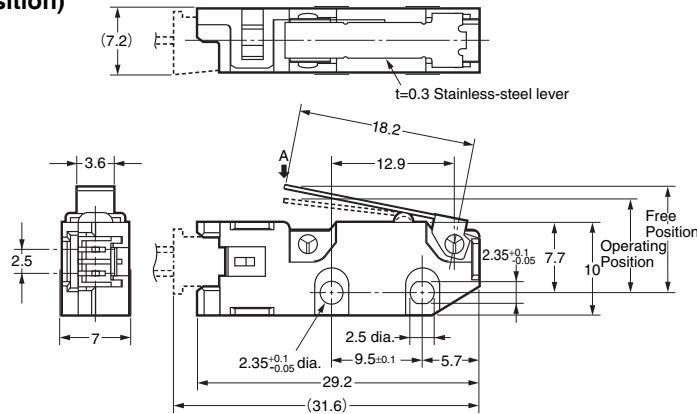
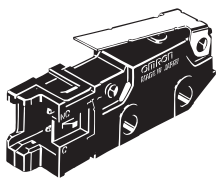

Models		D3M-01K1 D3M-01K1-3
Operating Characteristics		
Operating Force	OF Max.	0.50 N {51 gf}
Releasing Force	RF Min.	0.06 N {6 gf}
Overtravel	OT Min.	1.2 mm
Movement Differential	MD Max.	0.8 mm
Free Position	FP Max.	14.0 mm
Operating Position	OP	10.0±0.8 mm

## ●Hinge Lever (L position)

D3M-01L1  
D3M-01L1-3

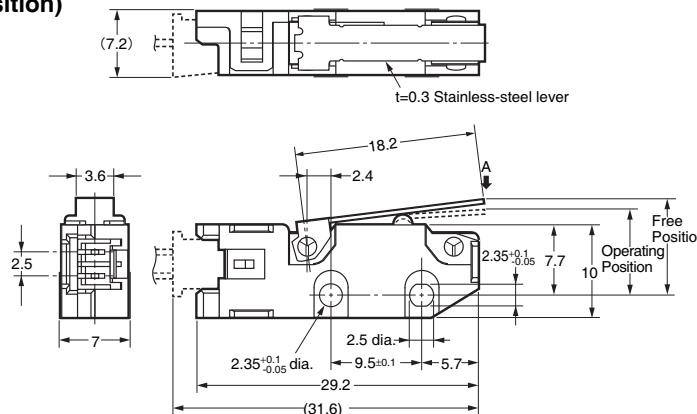
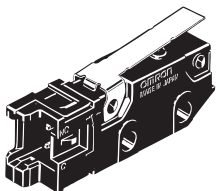

Models		D3M-01L1 D3M-01L1-3
Operating Characteristics		
Operating Force	OF Max.	1.00 N {102 gf}
Releasing Force	RF Min.	0.10 N {10 gf}
Overtravel	OT Min.	0.7 mm
Movement Differential	MD Max.	0.6 mm
Free Position	FP Max.	11.5 mm
Operating Position	OP	9.2±0.6 mm

## ●Hinge Roller Lever (K position)

D3M-01K2  
D3M-01K2-3

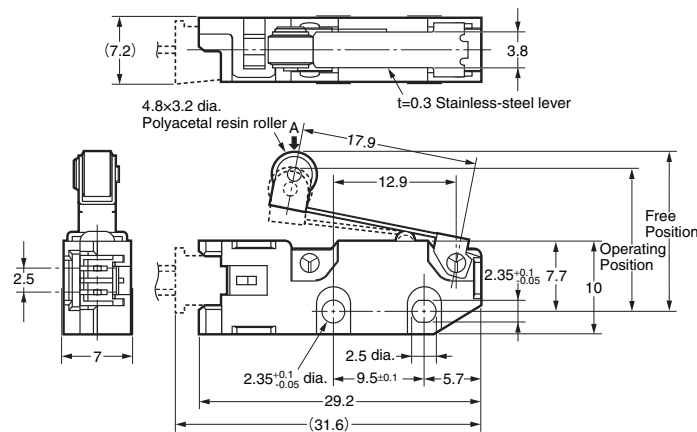
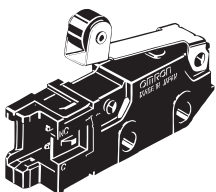

Models		D3M-01K2 D3M-01K2-3
Operating Characteristics		
Operating Force	OF Max.	0.50 N {51 gf}
Releasing Force	RF Min.	0.06 N {6 gf}
Overtravel	OT Min.	1.2 mm
Movement Differential	MD Max.	0.8 mm
Free Position	FP Max.	19.7 mm
Operating Position	OP	15.7±0.8 mm

## ●Hinge Roller Lever (L position)

D3M-01L2  
D3M-01L2-3

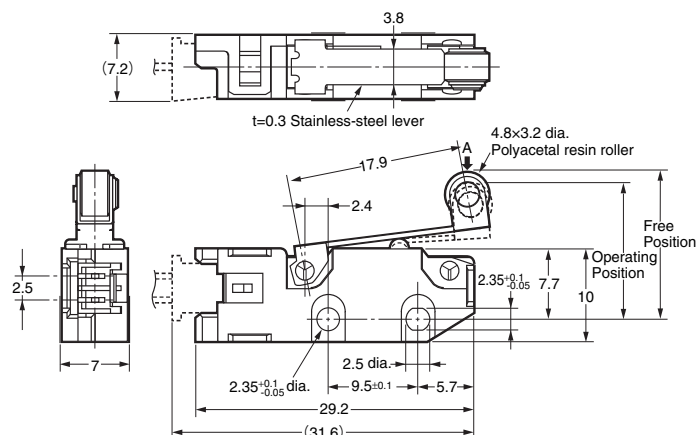
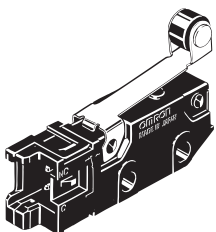

Models		D3M-01L2 D3M-01L2-3
Operating Characteristics		
Operating Force	OF Max.	1.00N {102 gf}
Releasing Force	RF Min.	0.10N {10 gf}
Overtravel	OT Min.	0.7mm
Movement Differential	MD Max.	0.6mm
Free Position	FP Max.	17.2 mm
Operating Position	OP	14.9±0.6 mm

Note 1. Unless otherwise specified, a tolerance of ±0.4 mm applies to all dimensions.

Note 2. The operating characteristics are for operation in the A direction (↓).

Note 3. The terminals connect to JST's Dipole XA Connector.

●**Simulated Roller Lever (K position)**  
**D3M-01K3**  
**D3M-01K3-3**

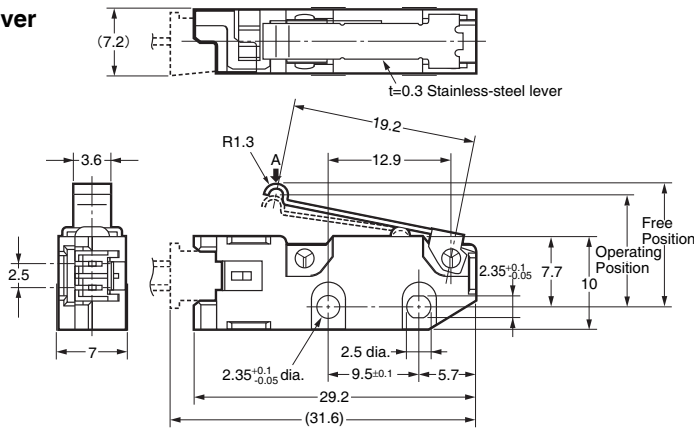
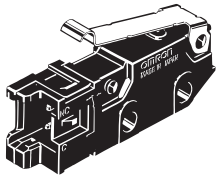

Models		D3M-01K3 D3M-01K3-3
Operating Characteristics		
Operating Force	OF Max.	0.50 N {51 gf}
Releasing Force	RF Min.	0.06 N {6 gf}
Overtravel	OT Min.	1.2 mm
Movement Differential	MD Max.	0.8 mm
Free Position	FP Max.	16.2 mm
Operating Position	OP	12.2±0.8 mm

●**Simulated Roller Lever (L position)**  
**D3M-01L3**  
**D3M-01L3-3**

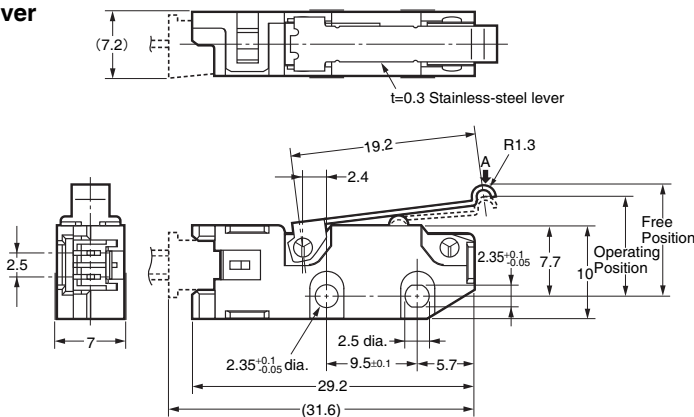
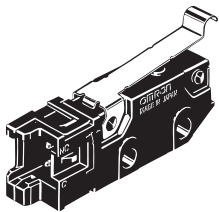

Models		D3M-01L3 D3M-01L3-3
Operating Characteristics		
Operating Force	OF Max.	1.00N {102 gf}
Releasing Force	RF Min.	0.10N {10 gf}
Overtravel	OT Min.	0.7 mm
Movement Differential	MD Max.	0.6 mm
Free Position	FP Max.	13.6 mm
Operating Position	OP	11.3±0.6 mm

Note 1. Unless otherwise specified, a tolerance of ±0.4 mm applies to all dimensions.  
 Note 2. The operating characteristics are for operation in the A direction (↓).  
 Note 3. The terminals connect to JST's Dipole XA Connector.

## Precautions

★Please refer to "Common Precautions" for correct use.

### Correct Use

●**Mounting**

Use M2.3 mounting screw with plane washers or spring washers to securely mount the Switch.

Tighten the screws to a torque of 0.23 to 0.26 N·m {2.3 to 2.7 kgf·cm}.

●**Wiring**

Do not use the Switch with Connector mounted and weight load applied to the Connector and lead wire, otherwise it may rattle or may result in connection failure.

●**Using Micro Loads**

Using a model for ordinary loads to open or close the contact of a micro load circuit may result in faulty contact. It is recommended to use the Switch in the operation range shown in the diagram. However, even when using micro load models within the operating range shown below, if inrush current occurs when the contact is opened or closed, it may increase contact

wear and so decrease durability. Therefore, insert a contact protection circuit where necessary.

The N-level reference value applies for the minimum applicable load. This value indicates the malfunction reference level for the reliability level of 60% ( $\lambda_{60}$ ). (JIS C5003)

The equation,  $\lambda_{60}=0.5 \times 10^{-6}/\text{operation}$  indicates that the estimated malfunction rate is less than  $\frac{1}{2,000,000}$  operations with a reliability level of 60%. This indicates that it is considered malfunction.

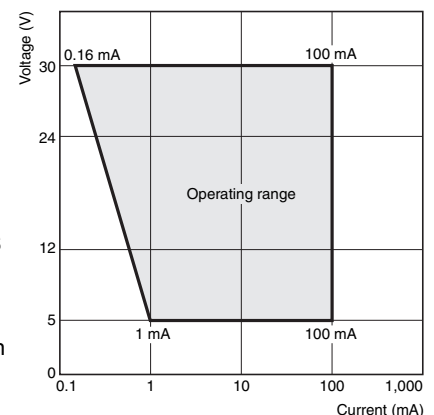

## Connector

- The terminals connect to JST's XA Connector.  
 Contact: SXA-001T-P0.6  
 Housing: XAP-02V-1
- OMRON does not sell the XA Connector.
- Contact JST Mfg. for more information on the connectors.

**J.S.T. Manufacturing Co., Ltd.**  
[http://www.jst-mfg.com/index\\_e.php](http://www.jst-mfg.com/index_e.php)

- Application examples provided in this document are for reference only. In actual applications, confirm equipment functions and safety before using the product.
- Consult your OMRON representative before using the product under conditions which are not described in the manual or applying the product to nuclear control systems, railroad systems, aviation systems, vehicles, combustion systems, medical equipment, amusement machines, safety equipment, and other systems or equipment that may have a serious influence on lives and property if used improperly. Make sure that the ratings and performance characteristics of the product provide a margin of safety for the system or equipment, and be sure to provide the system or equipment with double safety mechanisms.

**Note: Do not use this document to operate the Unit.**