

Logic Diagram

FEATURES:

- 3.3V ABT octal buffers/drivers with 3-state outputs
- RAD-PAK® radiation-hardened against natural space radiation
- Package:
 - 20 Pin RAD-PAK® flat package
- Operating temperature range:
 - 55 to 125°C
- Supports mixed-mode signal operation
 - 5V input with 3.3V V_{CC}
- Supports unregulated battery operation down to 2.7V
- Typical V_{OLP} (output ground bounce) < 0.8V at $V_{CC}=3.3V$, $T_A=25^\circ C$
- Supports live insertion
- Bus-hold data inputs eliminate the need for external pullup resistors

DESCRIPTION:

Maxwell Technologies' 54LVTH244A octal buffers/drivers micro-circuit is housed in a Rad-Pak® package. The 54LVTH244A is designed specifically for low voltage (3.3V) V_{CC} operation, but with the capability to provide a TTL interface to a 5V system environment. The 54LVTH244A is organized as two 4-bit drivers with separate output enable (\overline{OE}) inputs. When \overline{OE} is low, the device passes data from the A inputs to the Y outputs. When \overline{OE} is high, the outputs are in the high impedance state. The 54LVTH244A active bus hold circuitry is provided to prevent floating data inputs at a valid logic level and to eliminate the need for pullup resistors.

Maxwell Technologies' patented RAD-PAK® packaging technology incorporates radiation shielding in the microcircuit package. It eliminates the need for box shielding while providing the required radiation shielding for a lifetime in orbit or a space mission. This product is available with packaging and screening up to Class S.

TABLE 1. PINOUT DESCRIPTION

PIN	SYMBOL	DESCRIPTION
1, 19	$\overline{1OE-2OE}$	Output Enable
2, 4, 6, 8	IA1-IA4	Input
3, 5, 7, 9	2Y4-2Y1	Output
10	GND	Ground
11, 13, 15, 17	2A1-2A4	Input
12, 14, 16, 18	1Y4-1Y1	Output
20	V_{CC}	Supply Voltage

TABLE 2. 54LVTH244A ABSOLUTE MAXIMUM RATINGS¹

PARAMETER	SYMBOL	MIN	NOM	MAX	UNIT
Supply Voltage Range	V_{CC}	-0.5	--	4.6	V
Input Voltage Range ²	V_I	-0.5	--	7.0	V
Voltage Range Applied to Any Output in the High State or Power-Off State	V_O	-0.5	--	7.0	V
Current into Any Output in the Low State	I_O	--	--	96	mA
Current Into Any Output in the High State ³	I_O	--	--	48	mA
Input Clamp Current ($V_I < 0$)	I_{IK}	--	--	-50	mA
Output Clamp Current ($V_O < 0$)	I_{OK}	--	--	-50	mA
Total Power Dissipation at $T_A = 55^\circ\text{C}$	P_D	--	--	650	mW
Thermal Resistance	T_{jc}	--	11.46	--	--
Weight	--	--	5	--	--
Operating Temperature	T_A	-55	--	125	$^\circ\text{C}$
Storage Temperature Range	T_S	-65	--	150	$^\circ\text{C}$

1. Stresses beyond those listed under "Absolute Maximum Ratings" may cause permanent damage to the device. These are stress ratings only, and functional operation of the device at these or any other conditions beyond those indicated under "Recommended Operating Conditions" is not implied. Exposure to absolute-maximum-rated conditions for extended periods may affect device reliability.
2. The input and output negative-voltage ratings may be exceeded if the input and output clamp-current ratings are observed.
3. This current flows only when the output is in the high state and $V_O > V_{CC}$.

TABLE 3. DELTA LIMITS

PARAMETER	VARIATION
$I_{CC(OL)}$	±10% of specified value on Table 5
I_{OZH}	±10% of specified value on Table 5
I_{OZL}	±10% of specified value on Table 5

TABLE 4. 54LVTH244A RECOMMENDED OPERATING CONDITIONS ¹

PARAMETER	SYMBOL	MIN	NOM	MAX	UNIT
Supply Voltage	V_{CC}	2.7		3.6	V
High-level Input Voltage	V_{IH}	2.0		--	V
Low-level Input Voltage	V_{IL}	--		0.8	V
Input Voltage	V_I	--		5.5	V
High-level Output Current	I_{OH}	--		-24	mA
Low-level Output Current	I_{OL}	--		48	mA
Input Transition Rise or Fall Rate	$\Delta t/\Delta v$	--		10	ns/V
Operating Temperature	T_A	-55		125	°C

1. All unused control inputs must be held high or low to ensure proper device operation.

TABLE 5. 54LVTH244A DC ELECTRICAL CHARACTERISTICS

($V_{CC} = 3.3V \pm 10\%$, $T_A = -55\text{ °C}$ TO 125 °C , UNLESS OTHERWISE SPECIFIED)

PARAMETER	SYMBOL	TEST CONDITIONS		MIN	MAX	UNIT
Input Clamp Voltage	V_{IK}	$V_{CC} = 2.7$	$I_I = -18\text{mA}$	--	-1.2	V
High-Level Output Voltage	V_{OH}	$V_{CC} = 2.7\text{V}$ to 3.6V	$I_{OH} = -100\mu\text{A}$	$V_{CC} - 0.2$	--	V
		$V_{CC} = 2.7\text{V}$	$I_{OH} = -8\text{mA}$	2.4	--	
		$V_{CC} = 3\text{V}$	$I_{OH} = 24\text{mA}$	2.0	--	
Low-Level Output Voltage	V_{OL}	$V_{CC} = 2.7\text{V}$	$I_{OL} = 100\mu\text{A}$	--	0.2	V
			$I_{OL} = 24\text{mA}$	--	0.5	
		$V_{CC} = 3\text{V}$	$I_{OL} = 16\text{mA}$	--	0.4	
			$I_{OL} = 32\text{mA}$	--	0.5	
			$I_{OL} = 32\text{mA}$	--	0.55	

TABLE 5. 54LVTH244A DC ELECTRICAL CHARACTERISTICS

(V_{CC} = 3.3V ± 10%, T_A = -55 °C to 125 °C, UNLESS OTHERWISE SPECIFIED)

PARAMETER	SYMBOL	TEST CONDITIONS			MIN	MAX	UNIT
Input Current	I _I	V _{CC} = 0 or 3.6V		V _I = V _{CC}		10	μA
		V _{CC} = 3.6V	V _I = V _{CC} or GND	Control Inputs	--	±1	
		V _{CC} = 3.6V	V _I = V _{CC}	Data Inputs	--	1	
V _I = 0			--	-5			
Hold Current	I _{I(HOLD)}	V _{CC} = 3V	V _I = 0.8V	Data Inputs	75	--	μA
			V _I = 2V		-75	--	
Output Disabled Leakage Current - High	I _{OZH}	V _{CC} = 3.6V, V _O = 3V			--	5	μA
Output Disabled Leakage Current - Low	I _{OZL}	V _{CC} = 3.6V, V _O = 0.5V			--	-5	μA
Power Up Current	I _{OZPU} ²	V _{CC} = 0 to 1.5V, V _O = 0.5V to 3V, \overline{OE} = don't care			--	±100	μA
Power Down Current	I _{OZPD} ²	V _{CC} = 1.5V to 0, V _O = 0.5V to 3V, \overline{OE} = don't care			--	±100	μA
Supply Current	I _{CC}	V _{CC} = 3.6V		Outputs high	--	0.19	mA
		I _O = 0		Outputs low	--	5	
		V _I = V _{CC} or GND		Outputs disabled	--	0.19	
Delta Supply Current	ΔI _{CC} ¹	V _{CC} = 3V to 3.6V, One input at V _{CC} - 0.6V, Other inputs at V _{CC} or GND			--	0.2	mA
Input Capacitance	C _I ²	V _I = 3V or 0			--	8	pF
Input Output Capacitance	C _O ²	V _O = 3V or 0			--	15	pF

1. This is the increase in supply current for each input that is at the specified TTL voltage level rather than V_{CC} or GND.
2. Guaranteed by design.

TABLE 6. 54LVTH244A AC ELECTRICAL CHARACTERISTICS

(T_A = -55 °C to 125 °C, C_L = 50 pF, UNLESS OTHERWISE SPECIFIED)

PARAMETER	SYMBOL	V _{CC} = 3.3V ± 0.3V		V _{CC} = 2.7V		UNIT
		MIN	MAX	MIN	MAX	
Propogation Delay Time A to Y	t _{PLH}	--	4.7	--	4.1	ns
	t _{PHL}	--	4.4	--	3.9	
Output Enable Time OE to Y	t _{PZH}	--	6.9	--	6.0	ns
	t _{PZL}	--	5.4	--	5.4	
Output Disable OE to Y	t _{PHZ}	--	6.2	--	5.8	ns
	t _{PLZ}	--	5.5	--	4.8	

TABLE 7. FUNCTION TABLE
(EACH BUFFER)

INPUTS		OUTPUT
\overline{OE}	A	Y
L	H	H
L	L	L
H	X	Z

FIGURE 1. LOAD CIRCUIT FOR OUTPUTS

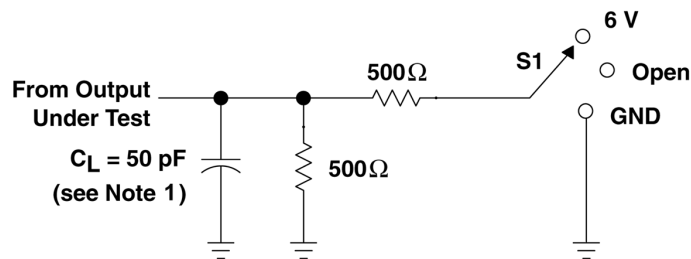

Figure 1 Note:
1. C_L includes probe and jig capacitance

PARAMETER MEASUREMENT INFORMATION

TEST	S1
T_{PLH}/T_{PHL}	Open
T_{PLZ}/T_{PZL}	6V
T_{PHZ}/T_{PZH}	GND

FIGURE 2. PULSE DURATION

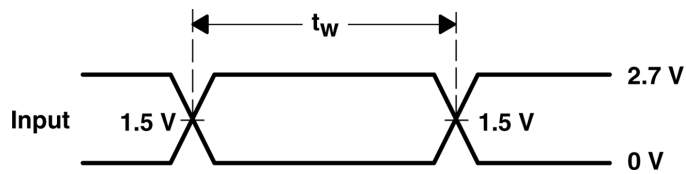

FIGURE 3. SETUP AND HOLD TIMES

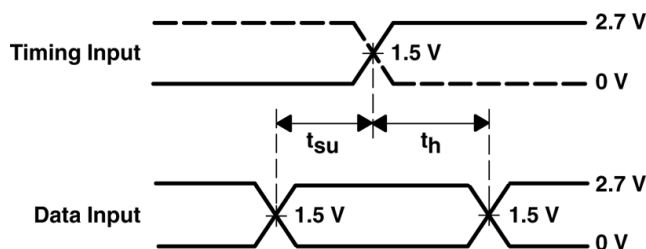

FIGURE 4. PROPAGATION DELAY TIMES INVERTING AND NON-INVERTING OUTPUTS

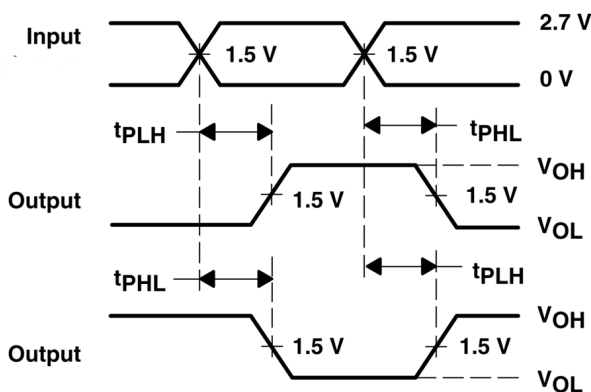

FIGURE 5. OUTPUT ENABLE TIMING

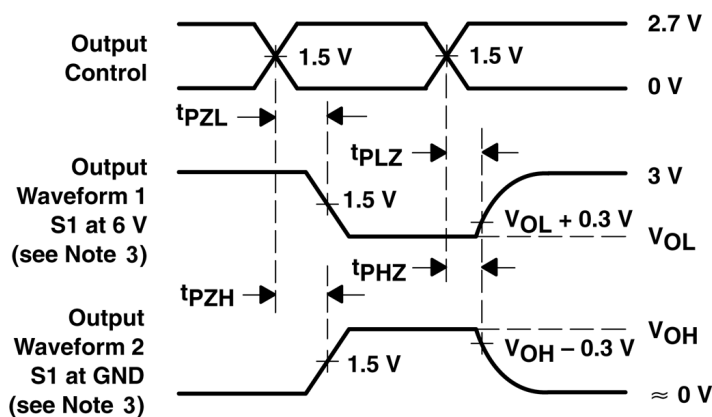
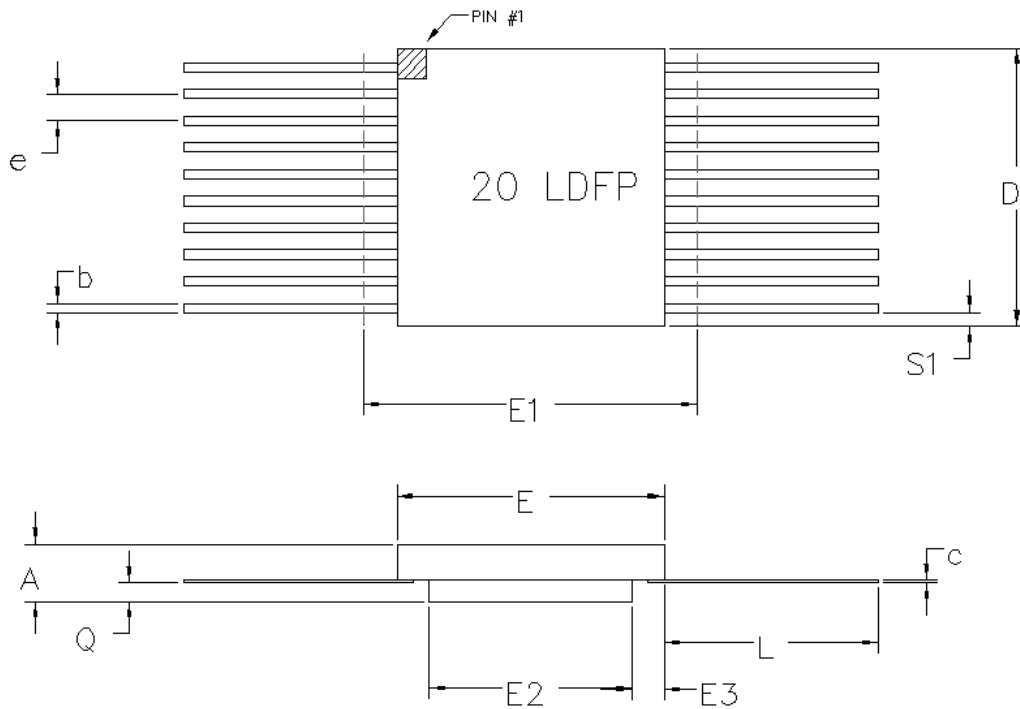

Figure Notes:

- All input pulses are supplied by generators having the following characteristics: $PRR \leq 10 \text{ MHz}$, $Z_0 = 50\Omega$, $t_r \leq 2.5 \text{ ns}$, $t_f \leq 2.5 \text{ ns}$.
- Waveform 1 is for an output with internal conditions such that the output is low except when disabled by the output control. Waveform 2 is for an output with internal conditions such that the output is high except when disabled by the output control.
- The outputs are measured one at a time with one transition per measurement.



20 PIN RAD-PAK® FLAT PACKAGE

SYMBOL	DIMENSION		
	MIN	NOM	MAX
A	0.128	0.141	0.154
b	0.015	0.017	0.022
c	0.003	0.005	0.009
D	0.470	0.480	0.490
E	0.287	0.295	0.303
E1	--	--	0.333
E2	0.155	0.160	--
E3	0.030	0.068	--
e	0.050 BSC		
L	0.370	0.380	0.390
Q	0.035	0.039	0.042
S1	0.005	0.007	--
N	20		

Note: All dimensions in inches

Important Notice:

These data sheets are created using the chip manufacturer's published specifications. Maxwell Technologies verifies functionality by testing key parameters either by 100% testing, sample testing or characterization.

The specifications presented within these data sheets represent the latest and most accurate information available to date. However, these specifications are subject to change without notice and Maxwell Technologies assumes no responsibility for the use of this information.

Maxwell Technologies' products are not authorized for use as critical components in life support devices or systems without express written approval from Maxwell Technologies.

Any claim against Maxwell Technologies must be made within 90 days from the date of shipment from Maxwell Technologies. Maxwell Technologies' liability shall be limited to replacement of defective parts.

3.3V ABT 8-Bit Octal Buffers/Drivers

54LVTH244A

Product Ordering Options

