

# 54LVTH16373

## 3.3V ABT16-Bit Transparent D-Type Latches

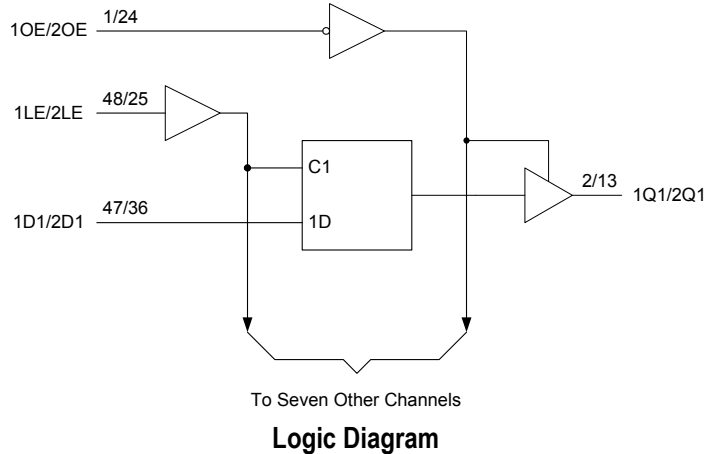
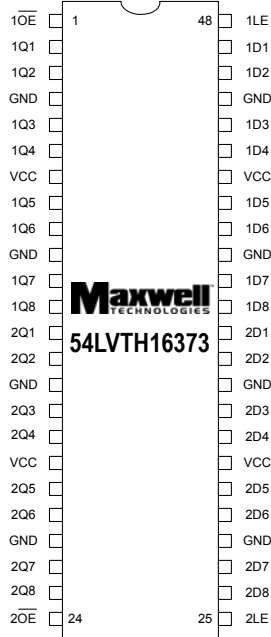

### FEATURES:

- 3.3V low voltage advanced BiCMOS technology (LVT) 16-bit transparent D-type latches with 3-state outputs
- Total dose hardness:
  - > 100 krad (Si), dependent upon space mission
- Single event effect:
  - $SEL_{TH}$ : No LU > 119 MeV/mg/cm<sup>2</sup>
- Package: 48 pin RAD-PAK® flat package
- Operating temperature range:
  - 55 to 125°C
- Distributed  $V_{CC}$  and GND pin configuration minimizes high-speed switching noise
- Supports mixed-mode signal operation
  - 5V input and output voltages with 3.3V  $V_{CC}$
- Supports unregulated battery operation down to 2.7V
- Typical  $V_{OLP}$  (output ground bounce) < 0.8V at  $V_{CC}=3.3V$ ,  $T_A=25^\circ C$
- Latch-up performance exceeds 500mA per JEDEC standard
- Supports live insertion
- Bus-hold data inputs eliminate the need for external pullup resistors

### DESCRIPTION:

Maxwell Technologies' 54LVTH16373 16-bit transparent D-type latches with 3-state output features a greater than 100 krad (Si) total dose tolerance, dependent upon space mission. The 54LVTH16373 is designed for low voltage (3.3V)  $V_{CC}$  operation, but with the capability to provide a TTL interface to a 5V system environment. It is suitable for implementing buffer registers, I/O ports, bidirectional bus drivers, and working registers. The 54LVTH16373 can be used as two 8-bit latches or one 16-bit latch. When the latch-enable (LE) input is low, the Q output are latched at the levels set up at the data (D) inputs. When LE is high, the Q outputs follow the D inputs. A buffered output-enable (OE) input can be used to place the eight outputs in either a normal logic state or a high impedance state. In the high impedance state, the outputs neither load nor drive the bus lines significantly. The high impedance state and the increased drive provide the capability to drive bus lines without the need for interface or pullup components. OE does not affect internal operations of the latch. Old data can be retained or new data can be entered while the outputs are in the high impedance state.

Maxwell Technologies' patented RAD-PAK® packaging technology incorporates radiation shielding in the microcircuit package. It eliminates the need for box shielding while providing the required radiation shielding for a lifetime in orbit or space mission. In a GEO orbit, RAD-PAK provides greater than 100 krad (Si) radiation dose tolerance. This product is available with screening up to Class S.

TABLE 1. PINOUT DESCRIPTION

PIN	SYMBOL	DESCRIPTION
1, 24	$\overline{1OE-2OE}$	Output Enable
2, 3, 5, 6, 8, 9, 11, 12	1Q1-1Q8	Outputs
4, 10, 15, 21, 28, 34, 39, 45	GND	Ground
7, 31, 42	$V_{CC}$	Power Supply
13, 14, 16, 17, 19, 20, 22, 23	2Q1-2Q8	Outputs
25, 48	2LE-1LE	Latch Enable
26, 27, 29, 30, 32, 31, 32, 33, 35, 36	2D8-2D1	Inputs
37, 38, 40, 41, 43, 44, 46, 47	1D8-1D1	Inputs

TABLE 2. 54LVTH16373 ABSOLUTE MAXIMUM RATINGS

PARAMETER	SYMBOL	MIN	MAX	UNIT
Supply voltage range	$V_{CC}$	-0.5	4.6	V
Input voltage range <sup>1</sup>	$V_I$	-0.5	7	V
Voltage range applied to any output in the high state or power-off state <sup>1</sup>	$V_O$	-0.5	7	V
Current into any output in the low state	$I_O$	--	96	mA
Current into any output in the high state <sup>2</sup>	$I_O$	--	48	mA
Input clamp current ( $V_I < 0$ )	$I_{IK}$	--	-50	mA
Output clamp current ( $V_O < 0$ )	$I_{OK}$	--	-50	mA
Maximum power dissipation at $T_A = 55^\circ\text{C}$ <sup>3</sup>	$P_D$	--	0.85	mW
Storage temperature range	$T_S$	-65	150	$^\circ\text{C}$

1. The input and output negative-voltage ratings may be exceeded if the input and output clamp-current ratings are observed.
2. This current flows only when the output is in the high state and  $V_O > V_{CC}$ .
3. The maximum package power dissipation is calculated using a junction temperature of  $150^\circ\text{C}$  and a board trace length of 750 mils.

TABLE 3. DELTA LIMITS

PARAMETER	VARIATION
$I_{CC(OL)}$	±10% of specified value in Table 5
$I_{CC(OH)}$	±10% of specified value in Table 5
$I_{CC(OD)}$	±10% of specified value in Table 5

TABLE 4. 54LVTH16373 RECOMMENDED OPERATING CONDITIONS <sup>1</sup>

PARAMETER	SYMBOL	MIN	MAX	UNIT
Supply voltage	$V_{CC}$	2.7	3.6	V
High-level input voltage	$V_{IH}$	2	--	V
Low-level input voltage	$V_{IL}$	--	0.8	V
Input voltage	$V_I$	--	5.5	V
High-level output current	$I_{OH}$	--	-24	mA
Low-level output current	$I_{OL}$	--	68	mA
Input transition rise or fall rate (outputs enabled)	$\Delta t/\Delta v$	--	10	ns/V
Operating free-air temperature	$T_A$	-55	125	°C

1. Unused control inputs must be held high or low to prevent them from floating.

TABLE 5. 54LVTH16373 DC ELECTRICAL CHARACTERISTICS

( $V_{CC} = 3.3V \pm 10\%$ ,  $T_A = -55$  to  $125^\circ\text{C}$ , UNLESS OTHERWISE SPECIFIED)

PARAMETER	SYMBOL	TEST CONDITIONS		MIN	MAX	UNIT	
Input Clamp Voltage	$V_{IK}$	$V_{CC} = 2.7$	$I_I = -18\text{mA}$	--	-1.2	V	
High-Level Output Voltage	$V_{OH}$	$V_{CC} = 2.7\text{V to } 3.6\text{V}$	$I_{OH} = -100\mu\text{A}$	$V_{CC} - 0.2$	--	V	
		$V_{CC} = 2.7\text{V}$	$I_{OH} = -8\text{mA}$	2.4	--		
		$V_{CC} = 3\text{V}$ ,	$I_{OH} = -32\text{mA}$	2.0	--		
Low-Level Output Voltage	$V_{OL}$	$V_{CC} = 2.7\text{V}$	$I_{OL} = 100\mu\text{A}$	--	0.2	V	
			$I_{OL} = 24\text{mA}$	--	0.5		
		$V_{CC} = 3\text{V}$	$I_{OL} = 16\text{mA}$	--	0.4		
			$I_{OL} = 32\text{mA}$	--	0.5		
Input Current	$I_I$	$V_{CC} = 0$ or $3.6\text{V}$		$V_I = 5.5\text{V}$		$\mu\text{A}$	
		$V_{CC} = 3.6\text{V}$	$V_I = V_{CC}$ or GND	Control Inputs	--		±1
		$V_{CC} = 3.6\text{V}$	$V_I = V_{CC}$	Data Inputs	--		1
			$V_I = 0$	Data Inputs	--		-5

TABLE 5. 54LVTH16373 DC ELECTRICAL CHARACTERISTICS

 $(V_{CC} = 3.3V \pm 10\%, T_A = -55 \text{ to } 125^\circ\text{C}, \text{ UNLESS OTHERWISE SPECIFIED})$ 

PARAMETER	SYMBOL	TEST CONDITIONS			MIN	MAX	UNIT
Hold Current	$I_{I(\text{HOLD})}$	$V_{CC} = 3V$	$V_I = 0.8V$	Data Inputs	75	--	$\mu\text{A}$
			$V_I = 2V$		-75	--	
Output Disabled Leakage Current - High	$I_{OZH}$	$V_{CC} = 3.6V, V_O = 3V$			--	5	$\mu\text{A}$
Output Disabled Leakage Current - Low	$I_{OZL}$	$V_{CC} = 3.6V, V_O = 0.5V$			--	-5	$\mu\text{A}$
Power Up Current	$I_{OZPU}^2$	$V_{CC} = 0 \text{ to } 1.5V, V_O = 0.5V \text{ to } 3V, \overline{OE} = \text{don't care}$			--	$\pm 100$	$\mu\text{A}$
Power Down Current	$I_{OZPD}^2$	$V_{CC} = 1.5V \text{ to } 0, V_O = 0.5V \text{ to } 3V, \overline{OE} = \text{don't care}$			--	$\pm 100$	$\mu\text{A}$
Supply Current	$I_{CC}$	$V_{CC} = 3.6V$ $I_O = 0$ $V_I = V_{CC} \text{ or } \text{GND}$	Outputs high		--	0.19	mA
			Outputs low		--	5	
			Outputs disabled		--	0.19	
Delta Supply Current	$\Delta I_{CC}^1$	$V_{CC} = 3V \text{ to } 3.6V, \text{ One input at } V_{CC} - 0.6V, \text{ Other inputs at } V_{CC} \text{ or } \text{GND}$			--	0.2	mA
Input Capacitance	$C_I^2$	$V_I = 3V \text{ or } 0$			--	10	pF
Input Output Capacitance	$C_O^2$	$V_O = 3V \text{ or } 0$			--	15	pF

1. This is the increase in supply current for each input that is at the specified TTL voltage level rather than  $V_{CC}$  or GND.
2. Guaranteed by design.

TABLE 6. 54LVTH16373 AC ELECTRICAL CHARACTERISTICS

 $(V_{CC} = 3.3V \pm 10\%, T_A = -55 \text{ to } 125^\circ\text{C}, \text{ UNLESS OTHERWISE SPECIFIED})$ 

PARAMETER	SYMBOL	$V_{CC} = 3.3V \pm 0.3V$		$V_{CC} = 2.7V$		UNIT
		MIN	MAX	MIN	MAX	
Pulse duration, LE high	$t_W$	3.3	--	3.3	--	ns
Setup time, data before LE $\emptyset$	$t_{SU}$	0.5	--	0.5	--	ns
Hold time, data after LE $\emptyset$	$t_H$	1.8	--	2	--	ns
Propagation Delay Time D to Q	$t_{PLH}$	2.7	5	--	5.7	ns
	$t_{PHL}$	2.9	4.9	--	5.7	
Propagation Delay Time LE to Q	$t_{PLH}$	3.6	6	--	6.8	ns
	$t_{PHL}$	4.7	6.9	--	8.8	
Output Enable Time $\overline{OE}$ to Q	$t_{PZH}$	2.9	5.3	--	6.3	ns
	$t_{PZL}$	3	5.1	--	5.9	

TABLE 6. 54LVTH16373 AC ELECTRICAL CHARACTERISTICS  
 ( $V_{CC} = 3.3V \pm 10\%$ ,  $T_A = -55$  to  $125^\circ C$ , UNLESS OTHERWISE SPECIFIED)

PARAMETER	SYMBOL	$V_{CC} = 3.3V \pm 0.3V$		$V_{CC} = 2.7V$		UNIT
		MIN	MAX	MIN	MAX	
Output Disable Time $\overline{OE}$ to Q	$t_{PHZ}$	4.3	6.8	--	7.6	ns
	$t_{PLZ}$	4	5.8	--	5.9	

TABLE 7. FUNCTION TABLE  
 (EACH 8-BIT SECTION)

INPUTS			OUTPUT Q
$\overline{OE}$	LE	D	
L	H	H	H
L	H	L	L
L	L	X	$Q_0$
H	X	X	Z

FIGURE 1. LOAD CIRCUIT FOR OUTPUTS

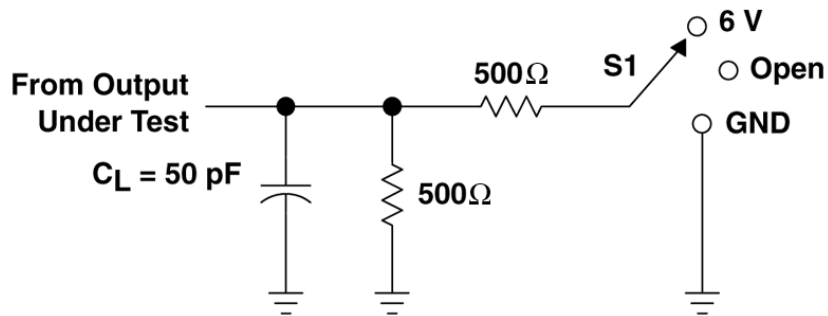

Figure Note:

- $C_L$  includes probe and jig capacitance.

### PARAMETER MEASUREMENT INFORMATION

TEST	S1
$T_{PLH}/T_{PHL}$	Open
$T_{PLZ}/T_{PZL}$	6V
$T_{PHZ}/T_{PZH}$	GND

FIGURE 2. PULSE DURATION

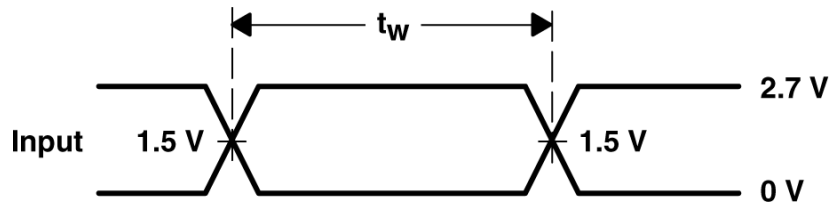

FIGURE 3. SETUP AND HOLD TIMES

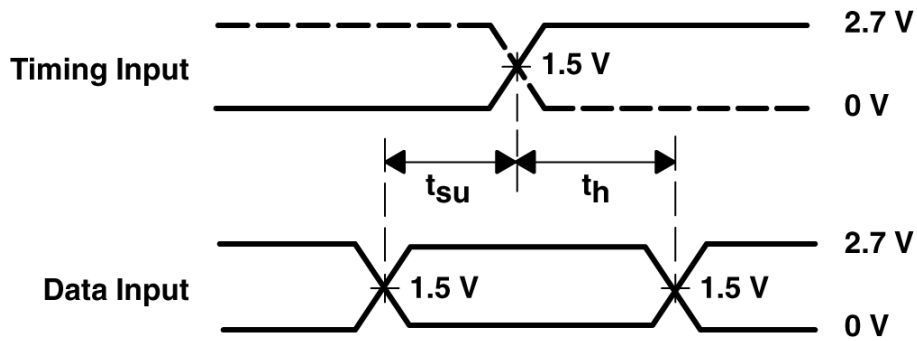

FIGURE 4. PROPAGATION DELAY TIMES INVERTING AND NON-INVERTING OUTPUTS

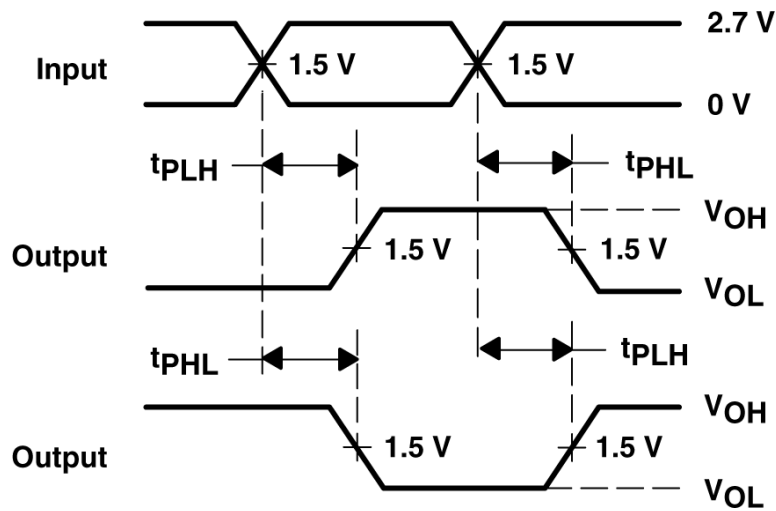
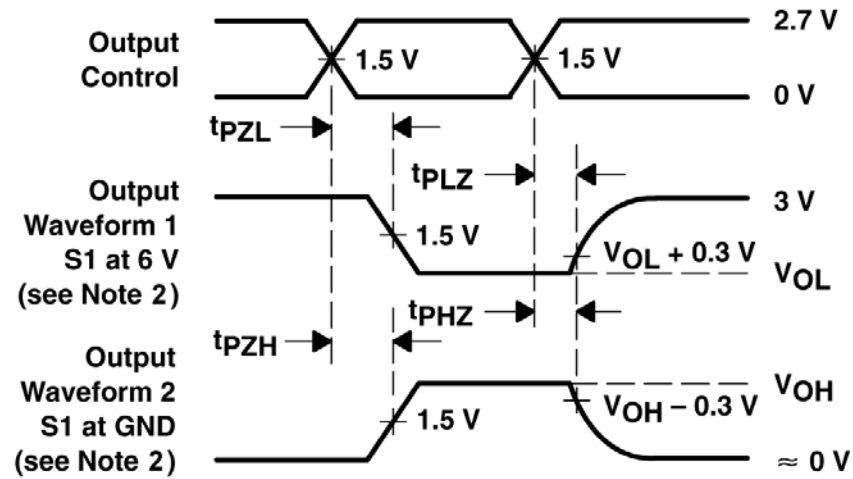
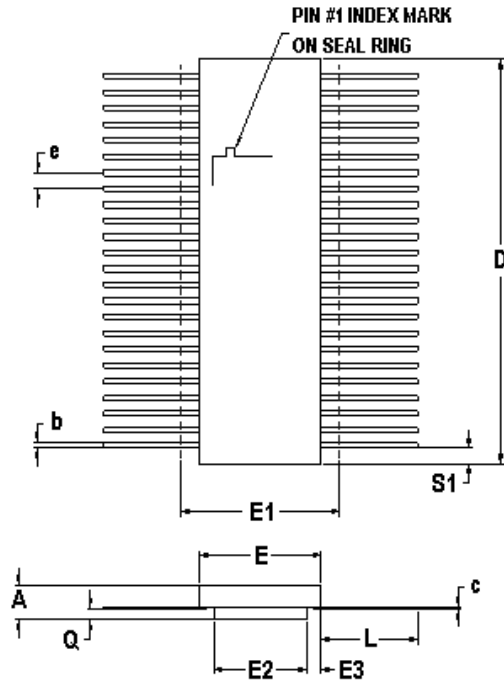

FIGURE 5. ENABLE AND DISABLE TIMES LOW- AND HIGH-LEVEL ENABLING



## FIGURE NOTES:

- Waveform 1 is for an output with internal conditions such that the output is low except when disabled by the output control. Waveform 2 is for an output with internal conditions such that the output is high except when disabled by the output control.
- All input pulses are supplied by generators having the following characteristics:  $PRR \leq 10 \text{ MHz}$ ,  $ZO = 5\Omega$ ,  $t_r \leq 2.5 \text{ ns}$ ,  $t_f \leq 2.5 \text{ ns}$ .
- The outputs are measured one at a time with one transition per measurement.



48 PIN RAD-PAK® FLAT PACKAGE

SYMBOL	DIMENSION		
	MIN	NOM	MAX
A	0.144	0.160	0.176
b	0.008	0.010	0.014
c	0.004	0.006	0.007
D	--	0.620	0.640
E	0.370	0.380	0.390
E1	--	--	0.410
E2	0.200	0.210	0.220
E3	0.075	0.085	--
e	0.025 BSC		
L	0.275	0.285	0.295
Q	0.013	0.019	0.045
S1	0.005	0.018	--
N	48		

F48-01

Note: All dimensions in inches

**Important Notice:**

These data sheets are created using the chip manufacturer's published specifications. Maxwell Technologies verifies functionality by testing key parameters either by 100% testing, sample testing or characterization.

The specifications presented within these data sheets represent the latest and most accurate information available to date. However, these specifications are subject to change without notice and Maxwell Technologies assumes no responsibility for the use of this information.

Maxwell Technologies' products are not authorized for use as critical components in life support devices or systems without express written approval from Maxwell Technologies.

Any claim against Maxwell Technologies must be made within 90 days from the date of shipment from Maxwell Technologies. Maxwell Technologies' liability shall be limited to replacement of defective parts.

# 3.3V ABT 16-Bit Transparent D-Type Latches

# 54LVTH16373

## Product Ordering Options

