

FEATURES:

- 3-state outputs drive bus lines or buffer memory address registers
- RAD-PAK® radiation-hardened against natural space radiation
- Total dose hardness:
 - > 100 krad (Si), depending upon space mission
- Package:
 - 20-pin RAD-PAK® flat package
- Operating temperature range: -55 to +125°C
- Bi-CMOS design
- ESD protection exceeds 2000V

DESCRIPTION:

Maxwell Technologies' 54BCT245 octal bus transceiver features a greater than 100 krad (Si) total dose tolerance. The 54BCT245 is designed specifically for asynchronous communication between data buses. The 54BCT245 transmits data from the A bus to the B bus or from the B bus to the A bus depending upon the level at the direction-control (DIR) input. The output-enable (OE) input can be used to disable the device so the buses are effectively isolated.

Maxwell Technologies' patented RAD-PAK® packaging technology incorporates radiation shielding in the microcircuit package. It eliminates the need for box shielding while providing the required radiation shielding for a lifetime in orbit or space mission. In a GEO orbit, RAD-PAK provides greater than 100 krad (Si) radiation dose tolerance. This product is available with screening up to Class S.

TABLE 1. PINOUT DESCRIPTION

PIN	SYMBOL	DESCRIPTION
1	DIR	Directional Control Input
2-9	A1-A8	Bi-directional I/O's with Tri-State
10	GND	Ground
11-18	B8-B1	Bi-directional I/O's with Tri-State
19	$\overline{\text{OE}}$	Output Enable
20	V_{CC}	Supply Power

TABLE 2. 54BCT245 ABSOLUTE MAXIMUM RATINGS ¹

PARAMETER	SYMBOL	MIN	MAX	UNIT
Supply Voltage Range	V_{CC}	-0.5	7.0	V
Input Voltage Range Control Input 3/I/O Ports ² I/O Ports ³	V_{I}	-0.5 -0.5	7.0 5.5	V
Voltage Range Applied to any Output in the Disable or Power-Off State	V_{O}	-0.5	7.0	V
Voltage Range Applied to any Output in High State	V_{O}	-0.5	V_{CC}	V
Current Into Any Output in the Low State	I_{O}	--	96	mA
Total Power Dissipation @ $T_{\text{A}} = +55^{\circ}\text{C}$ ³	P_{D}	--	651	mW
Input Clamp Current	$I_{\text{IK}} (V_{\text{I}} < 0)$	--	-30	mA
Operating Temperature Range	T_{A}	-55	125	$^{\circ}\text{C}$
Storage Temperature Range	T_{S}	-65	150	$^{\circ}\text{C}$

1. Stresses above the absolute maximum rating may cause permanent damage to the device. Extended operation at the maximum levels may degrade performance and affect reliability.
2. The input and output voltage ratings may be exceeded if the input and output current ratings are observed.
3. Must be able to withstand the additional P_{D} due to short circuit test, e.g. I_{DS} . The P_{D} number is based upon dc values.

TABLE 3. DELTA LIMITS

PARAMETER	VARIATION
$I_{\text{CC(OL)}}$	$\pm 10\%$ of specified value in Table 5
$I_{\text{CC(OH)}}$	$\pm 10\%$ of specified value in Table 5
$I_{\text{CC(OD)}}$	$\pm 10\%$ of specified value in Table 5

TABLE 4. 54BCT245 RECOMMENDED OPERATING CONDITIONS¹

PARAMETER	SYMBOL	MIN	MAX	UNIT
Supply Voltage	V_{CC}	4.5	5.5	V
High-Level Input Voltage	V_{IH}	2.0	--	V
Low-Level Input Voltage	V_{IL}	--	0.8	V
High-Level Output Current A Port B Port	I_{OH}	--	-3 -12	mA
Low-Level Output Current A Port B Port	I_{OL}	--	20 48	mA
Input Clamp Current	I_{IK}	--	-18	mA
Thermal Impedance — Flat Package	Θ_{JC}	--	5.56	°C/W
Operating Temperature	T_A	-55	125	°C

1. All unused control inputs must be held high or low to ensure proper device operation.

TABLE 5. 54BCT245 DC ELECTRICAL CHARACTERISTICS

($V_{CC} = 5V \pm 10\%$, $T_A = -55^\circ\text{C}$ to 125°C , UNLESS OTHERWISE SPECIFIED)

PARAMETER	SYMBOL	TEST CONDITIONS		SUBGROUPS	MIN	MAX	UNIT	
Input Clamp Voltage	V_{IK}	$V_{CC} = 4.5\text{ V}$		1, 2, 3	--	-1.2	V	
High-Level Output Voltage	V_{OH}	$V_{CC} = 4.5\text{ V}$	Port A	$I_{OH} = -1\text{ mA}$	1, 2, 3	2.5	--	V
				$I_{OH} = -3\text{ mA}$		2.4	--	
			Port B	$I_{OH} = -3\text{ mA}$		2.4	--	
				$I_{OH} = -12\text{ mA}$		2	--	
Low-Level Output Voltage	V_{OL}	$V_{CC} = 4.5\text{ V}$	Port A	$I_{OL} = 20\text{ mA}$	1, 2, 3	--	0.5	V
			Port B	$I_{OL} = 48\text{ mA}$		--	0.55	
Input Current	I_I	$V_{CC} = 5.5\text{ V}$	A or B Port	$V_I = 5.5\text{ V}$	1, 2, 3		1	mA
			Control Input				0.1	
High Level Input Current ¹	I_{IH}	$V_{CC} = 5.5\text{ V}$	A or B Port	$V_I = 2.7\text{ V}$	1, 2, 3	--	70	μA
			Control Input			--	20	
Low Level Input Current ²	I_{IL}	$V_{CC} = 5.5\text{ V}$	A or B Port	$V_{IN} = 0.5\text{ V}$	1, 2, 3	--	-0.65	mA
			Control Input			--	-1.2	
Short-circuit Output Current ²	I_{OS}	$V_{CC} = 5.5\text{ V}$	A Port	$V_O = 0\text{ V}$	1, 2, 3	-60	-150	mA
			B Port			-100	-225	
Supply Current, Outputs High	I_{CCH}		A to B	$V_{CC} = 5.5\text{ V}$	1, 2, 3	--	57	mA
Supply Current, Outputs Low	I_{CCL}		A to B	$V_{CC} = 5.5\text{ V}$	1, 2, 3	--	90	mA

TABLE 5. 54BCT245 DC ELECTRICAL CHARACTERISTICS
($V_{CC} = 5V \pm 10\%$, $T_A = -55^\circ C$ TO $125^\circ C$, UNLESS OTHERWISE SPECIFIED)

PARAMETER	SYMBOL	TEST CONDITIONS		SUBGROUPS	MIN	MAX	UNIT
Supply Current, Outputs Disabled to High Impedance State	I_{CCZ}	$V_{CC} = 5.5 V$		1, 2, 3	--	15	mA
Input Capacitance	C_i^3	$V_i = 2.5 V$ or $0.5V$	Control Input	$V_{CC} = 5.5 V$	1, 2, 3	7	pF
Input Output Capacitance	C_{io}^3	$V_{CC} = 5.5 V$	A to B	$V_i = 2.5 V$ or $0.5 V$		9	pF
			B to A			12	

1. For I/O ports, the parameters I_{IH} and I_{IL} include the off-state output current.
2. Not more than one output should be shorted at one time and the duration of test shall not exceed one second.
3. Guaranteed by design.

TABLE 6. 54BCT245 AC ELECTRICAL CHARACTERISTICS
($V_{CC} = 5V \pm 10\%$, $T_A = -55^\circ C$ TO $125^\circ C$, UNLESS OTHERWISE SPECIFIED)

PARAMETER	SYMBOL	TEST CONDITIONS		SUBGROUPS	MIN	MAX	UNIT
Propagation Delay Time from A or B to B or A	t_{PLH}	$V_{CC} = 4.5$ to $5.5 V$ $R_1 = 500 \Omega$	$C_L = 50 pF$ $R_2 = 500 \Omega$	9, 10, 11	1	7.2	ns
	t_{PHL}	$T_A = -55$ to $+125^\circ C$			1.5	7.6	
	t_{PLH}	$V_{CC} = 5.0 V$ $R_1 = 500 \Omega$	$C_L = 50 pF$ $R_2 = 500 \Omega$		1	6	
	t_{PHL}	$T_A = +25^\circ C$			1.5	6.6	
Output Enable Time OE to Yn	t_{PZH}	$V_{CC} = 4.5$ to $5.5 V$ $R_1 = 500 \Omega$	$C_L = 50 pF$ $R_2 = 500 \Omega$	9, 10, 11	1.5	11.2	ns
	t_{PZL}	$T_A = -55$ to $+125^\circ C$			1.5	11.8	
	t_{PZH}	$V_{CC} = 5.0 V$ $R_1 = 500 \Omega$	$C_L = 50 pF$ $R_2 = 500 \Omega$		1.5	9.4	
	t_{PZL}	$T_A = +25^\circ C$			1.5	10.2	
Output Disable Time OE to Yn	t_{PHZ}	$V_{CC} = 4.5$ to $5.5 V$ $R_1 = 500 \Omega$	$C_L = 50 pF$ $R_2 = 500 \Omega$	9, 10, 11	1.5	9.7	ns
	t_{PLZ}	$T_A = -55$ to $+125^\circ C$			1.5	9.6	
	t_{PHZ}	$V_{CC} = 5.0 V$ $R_1 = 500 \Omega$	$C_L = 50 pF$ $R_2 = 500 \Omega$		1.5	8.3	
	t_{PLZ}	$T_A = +25^\circ C$			1.5	7.8	

TABLE 7. FUNCTION TABLE

INPUTS		OPERATION
$\overline{\text{OE}}$	DIR	
L	L	B data to A bus
L	H	A data to B bus
H	X	Isolation

FIGURE 1. LOAD CIRCUIT FOR OUTPUTS

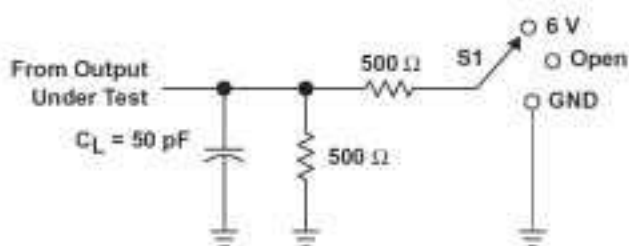

Figure Note:
1. C_L includes probe and jig capacitance.

PARAMETER MEASUREMENT INFORMATION

TEST	S1
T_{PLH}/T_{PHL}	Open
T_{PLZ}/T_{PZL}	6V
T_{PHZ}/T_{PZH}	GND

FIGURE 2. VOLTAGE WAVEFORMS PULSE DURATION

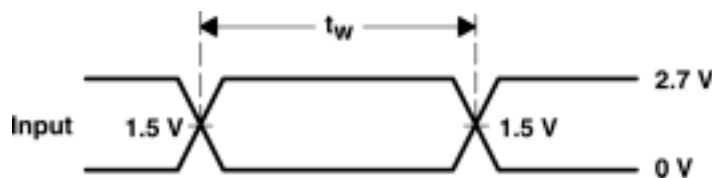

FIGURE 3. OUTPUT ENABLE TIMING

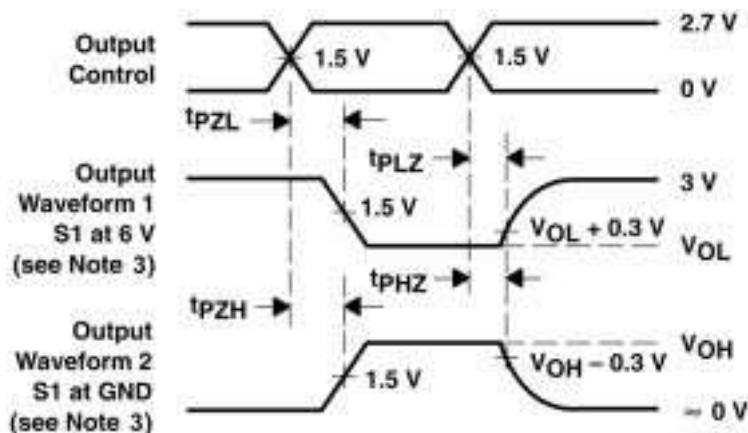

FIGURE 4. VOLTAGE SETUP AND HOLD TIMES

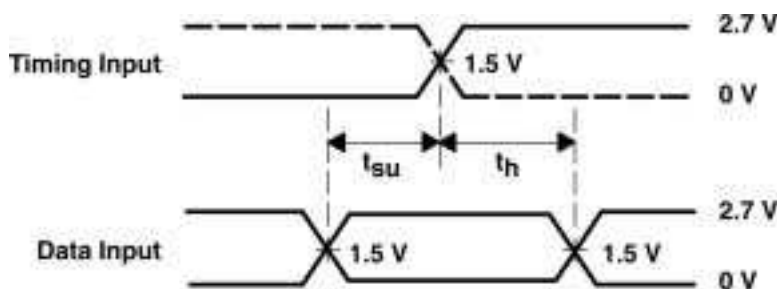

FIGURE 5. PROPAGATION DELAY TIMES INVERTING AND NON-INVERTING OUTPUTS

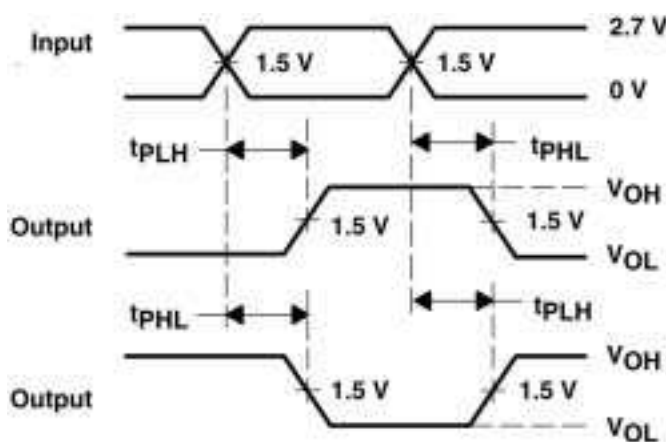
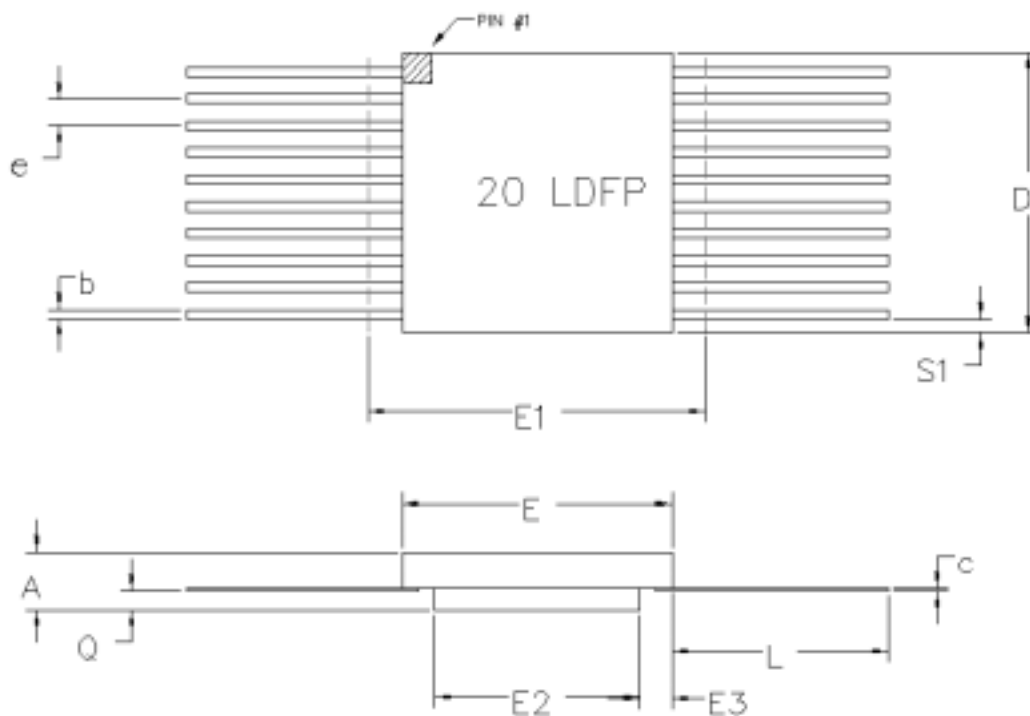

Figure Notes:

2. All input pulses are supplied by generators having the following characteristics: $PRR \leq 10 \text{ MHz}$, $Z_0 = 50\Omega$, $t_r \leq 2.5 \text{ ns}$, $t_f \leq 2.5 \text{ ns}$.
3. Waveform 1 is for an output with internal conditions such that the output is low except when disabled by the output control. Waveform 2 is for an output with internal conditions such that the output is high except when disabled by the output control.
4. The outputs are measured one at a time with one transition per measurement.



20 PIN RAD-PACK® FLAT PACKAGE

SYMBOL	DIMENSION		
	MIN	NOM	MAX
A	0.128	0.141	0.154
b	0.015	0.017	0.022
c	0.003	0.005	0.009
D	0.470	0.480	0.490
E	0.287	0.295	0.303
E1	--	--	0.333
E2	0.155	0.160	--
E3	0.030	0.068	--
e	0.050BSC		
L	0.370	0.380	0.390
Q	0.035	0.039	0.042
S1	0.005	0.007	--
N	20		

F20-01

Note: All dimensions in inches

Important Notice:

These data sheets are created using the chip manufacturer's published specifications. Maxwell Technologies verifies functionality by testing key parameters either by 100% testing, sample testing or characterization.

The specifications presented within these data sheets represent the latest and most accurate information available to date. However, these specifications are subject to change without notice and Maxwell Technologies assumes no responsibility for the use of this information.

Maxwell Technologies' products are not authorized for use as critical components in life support devices or systems without express written approval from Maxwell Technologies.

Any claim against Maxwell Technologies must be made within 90 days from the date of shipment from Maxwell Technologies. Maxwell Technologies' liability shall be limited to replacement of defective parts.

Octal Buffers Transceiver

54BCT245

Product Ordering Options

