

### FEATURES:

- RAD-PAK® Technology hardened against natural space radiation
- Total dose hardness >100 Krads (Si), dependent upon orbit
- Package:
  - 16 Pin RAID-PAK® flat pack
- On-resistance, <400 Ohms max
- Transition time, <500ns
- On-resistance match, <10 Ohms
- NO-Off leakage current, <20pA at 25°C
- 1.5pC charge injection
- Single-supply operation (4.5V to 30V)  
bipolar-supply operation (±4.5V to ±20V)
- Plug-in upgrade for industry-standard DG508A/DG509A
- Rail-to-rail signal handling
- TTL/CMOS-logic compatible

### DESCRIPTION:

Maxwell Technologies' 338 monolithic, CMOS analog multiplexer features the 338 is designed to connect one of eight inputs to a common output by control of a 3-bit binary address, and may be used as either a mux or a demux. On-resistance is 400 ohms max, and it conducts current equally well in both directions. These muxes feature extremely low off leakages (less than 20pA at 25°C), and extremely low on-channel leakages (less than 50pA at 25°C). The new design offers guaranteed low charge injection (1.5pC typ) and electrostatic discharge (ESD) protection greater than 2000V, per method 3015.7. The 338 operates from a single 4.5V to 30V supply or from dual supplies of ±4.5V to ±20V. All control inputs (whether address or enable) are TTL compatible (0.8V to 2.4V) over the full specified temperature range and over the ±4.5V to ±18V supply range. Capable of surviving space environments, the 338 is ideal for satellite, spacecraft, and space probe missions. The patented radiation-hardened RAD-PAK® technology incorporates radiation shielding in the microcircuit package. It eliminates box shielding while providing required lifetime in orbit. This product is available up to Class S packaging and screening.

TABLE 1. ABSOLUTE MAXIMUM RATINGS

PARAMETER	SYMBOL	MIN	MAX	UNITS
Voltage Referenced to V- V+ GND	--	-0.3 -0.3	44 25	V
Digital Inputs, NO, COM	--	V- -2	V+ +2	V
Continuous Current (any terminal)	--	--	30	mA
Peak Current, NO or COM (pulsed at 1ms, 10% duty cycle max)	--	--	100	mA
Operating Temperature Ranges	--	-55	125	°C
Storage Temperature Range	--	-65	150	°C
Lead Temperature (soldering, 10sec)	--	--	300	°C

TABLE 2. 338RP ELECTRICAL CHARACTERISTICS - SINGLE SUPPLY

(V+ = +12V, V- = 0V, V<sub>AH</sub> = 2.4V, V<sub>AL</sub> = 0.8V, T<sub>A</sub> = T<sub>MIN</sub> TO T<sub>MAX</sub>, UNLESS OTHERWISE SPECIFIED)

PARAMETER	SYMBOL	CONDITIONS	SUBGROUPS	MIN	TYP <sup>1</sup>	MAX	UNITS
SWITCH							
Analog Signal Range	V <sub>NO</sub> , V <sub>COM</sub>		1, 2, 3	0	--	12	V
On-Resistance	R <sub>ON</sub>	I <sub>NO</sub> = 0.2mA V <sub>COM</sub> = 3V or 10V T <sub>A</sub> = 25 °C		--	460	650	Ω
DYNAMIC							
Transition Time	t <sub>TRANS</sub>	V <sub>NO1</sub> = 8V V <sub>NO8</sub> = 0V V <sub>IN</sub> = 2.4V T <sub>A</sub> = 25 °C	9	--	210	500	ns
Enable Turn-On Time	t <sub>ON(EN)</sub>	V <sub>INH</sub> = 2.4V V <sub>INL</sub> = 0V V <sub>NO1</sub> = 5V T <sub>A</sub> = 25 °C	9	--	280	500	ns
Enable Turn-Off Time	t <sub>OFF(EN)</sub>	V <sub>INH</sub> = 2.4V V <sub>INL</sub> = 0V V <sub>NO1</sub> = 5V T <sub>A</sub> = 25 °C	9	--	110	500	ns
Charge Injection <sup>2</sup>	Q	CL = 100pF V <sub>NO</sub> = 0V R <sub>S</sub> = 0 Ohms T <sub>A</sub> = 25C		--	1.8	5	pC

1. The algebraic convention where the most negative value is a minimum and the most positive value a maximum is used in this data sheet.

2. Guaranteed by Design

TABLE 3. ELECTRICAL CHARACTERISTICS - DUAL SUPPLIES

(V+ = 15V, V- = -15V, GND = 0V, V<sub>AH</sub> = 2.4V, V<sub>AL</sub> = 0.8V, T<sub>A</sub> = T<sub>MIN</sub> TO T<sub>MAX</sub>, UNLESS OTHERWISE SPECIFIED)

PARAMETER	SYMBOL	CONDITIONS	SUBGROUPS	MIN	TYP <sup>1</sup>	MAX	UNITS	
<b>SWITCH</b>								
Analog Signal Range	V <sub>NO</sub> , V <sub>COM</sub>		1, 2, 3	-15	--	15	V	
On-Resistance	R <sub>ON</sub>	I <sub>NO</sub> = -0.2mA V <sub>COM</sub> = 10V	T <sub>A</sub> = 25 °C	--	220	400	Ω	
			T <sub>A</sub> = T <sub>MIN</sub> to T <sub>MAX</sub>	--	--	500		
On-Resistance Matching Between Channels <sup>2,3</sup>	D R <sub>ON</sub>	I <sub>NO</sub> = -0.2mA V <sub>COM</sub> = 10V	T <sub>A</sub> = 25 °C	--	4	10	Ω	
			T <sub>A</sub> = T <sub>MIN</sub> to T <sub>MAX</sub> <sup>3</sup>	--	--	15		
NO-Off Leakage Current <sup>4</sup>	I <sub>NO(OFF)</sub>	V <sub>COM</sub> = 10V V <sub>NO</sub> = 10V V <sub>EN</sub> = 0V	T <sub>A</sub> = 25 °C	1	-0.02	0.001	0.02	nA
			T <sub>A</sub> = T <sub>MIN</sub> to T <sub>MAX</sub>	2, 3	-20	--	20	
COM-Off Leakage Current <sup>4</sup>	I <sub>COM(OFF)</sub>	V <sub>COM</sub> = 10V V <sub>NO</sub> = 10V V <sub>EN</sub> = 0V	T <sub>A</sub> = 25 °C	1	-0.05	0.05	0.05	nA
			T <sub>A</sub> = T <sub>MIN</sub> to T <sub>MAX</sub>	2, 3	-40	--	40	
COM-On Leakage Current <sup>4</sup>	I <sub>COM(ON)</sub>	V <sub>COM</sub> = 10V V <sub>NO</sub> = 10V sequence each switch on	T <sub>A</sub> = 25 °C	1	-0.05	0.06	0.05	nA
			T <sub>A</sub> = T <sub>MIN</sub> to T <sub>MAX</sub>	2, 3	-40	--	40	
<b>INPUT</b>								
Input Current with Input Voltage High	I <sub>AH</sub>	V <sub>A</sub> = 2.4V or 15V	1, 2, 3	-1.0	0.001	1.0	uA	
Input Current with Input Voltage Low	I <sub>AL</sub>	V <sub>EN</sub> = 0V or 2.4V, V <sub>A</sub> = 0V	1, 2, 3	-1.0	--	1.0	uA	
<b>SUPPLY</b>								
Power-Supply Range	--	--	--	1, 2, 3	4.5	--	20	V
Positive Supply Current	I+	V <sub>EN</sub> = V <sub>A</sub> = 0V V <sub>EN</sub> = 2.4V V <sub>A(ALL)</sub> = 2.4V	T <sub>A</sub> = 25 °C	1	--	--	100	uA
			T <sub>A</sub> = T <sub>MIN</sub> to T <sub>MAX</sub>	2, 3	--	--	150	
			T <sub>A</sub> = 25 °C	1	--	290	500	
			T <sub>A</sub> = T <sub>MIN</sub> to T <sub>MAX</sub>	2, 3	--	--	600	
Negative Supply Current	I-	V <sub>EN</sub> = 0V or 2.4V V <sub>A(ALL)</sub> = 0V or 2.4V or 5V	T <sub>A</sub> = 25 °C	1	-1	--	1	uA
			T <sub>A</sub> = T <sub>MIN</sub> to T <sub>MAX</sub>	2, 3	-10	--	10	

TABLE 3. ELECTRICAL CHARACTERISTICS - DUAL SUPPLIES

(V+ = 15V, V- = -15V, GND = 0V, V<sub>AH</sub> = 2.4V, V<sub>AL</sub> = 0.8V, T<sub>A</sub> = T<sub>MIN</sub> TO T<sub>MAX</sub>, UNLESS OTHERWISE SPECIFIED)

PARAMETER	SYMBOL	CONDITIONS	SUBGROUPS	MIN	TYP <sup>1</sup>	MAX	UNITS
DYNAMIC							
Transition Time	t <sub>TRANS</sub>	Figure 2.	T <sub>A</sub> = 25 °C	9	--	200	500 ns
Break-Before-Make Interval	t <sub>OPEN</sub>	Figure 4.	T <sub>A</sub> = 25 °C	9	10	140	-- ns
Enable Turn-On Time	t <sub>ON(EN)</sub>	Figure 3.	T <sub>A</sub> = 25 °C	9	--	160	500 ns
			T <sub>A</sub> = T <sub>MIN</sub> to T <sub>MAX</sub>	10, 11	--	--	750
Enable Turn-Off Time	t <sub>OFF(EN)</sub>	Figure 3.	T <sub>A</sub> = 25 °C	9	--	100	500 ns
			T <sub>A</sub> = T <sub>MIN</sub> to T <sub>MAX</sub>	10, 11	--	--	750
Off Isolation <sup>5,6</sup>	V <sub>ISO</sub>	V <sub>EN</sub> = 0V, R <sub>L</sub> = 1kW, T <sub>A</sub> = +25 °C f = 100kHz	4	--	-75	--	dB
Crosstalk Between Channels	V <sub>CT</sub>	V <sub>EN</sub> = 2.4V, f = 100kHz, T <sub>A</sub> = +25 °C V <sub>GEN</sub> = 1Vp-p, R <sub>L</sub> = 1kW	4	--	-92	--	dB
Logic Input Capacitance	C <sub>IN</sub>	f = 1MHz, T <sub>A</sub> = +25 °C		--	2	--	pF
NO-Off Capacitance	C <sub>NO(OFF)</sub>	f = 1MHz, V <sub>EN</sub> = V <sub>NO</sub> = 0V T <sub>A</sub> = +25 °C, Figure 8.		--	3	--	pF
COM-Off Capacitance	C <sub>COM(OFF)</sub>	f = 1MHz, V <sub>EN</sub> = 0.8V T <sub>A</sub> = +25 °C, V <sub>COM</sub> = 0V, Figure 8.		--	11	--	pF
COM-On Capacitance	C <sub>COM(ON)</sub>	f = 1MHz, V <sub>EN</sub> = 2.4V, T <sub>A</sub> = +25 °C V <sub>COM</sub> = 0V, Figure 8		--	16	--	pF

1. The algebraic convention where the most negative value is a minimum and the most positive value a maximum is used in this data sheet.
2. Characterized and not 100% tested.
3. DR<sub>ON</sub> = R<sub>ON(MAX)</sub> - R<sub>ON(MIN)</sub>.
4. Leakage parameters are 100% tested at the maximum rated hot temperature and guaranteed at 25 °C.
5. Guaranteed by design.
6. Worst-case isolation is on channel 4 because of its proximity to the drain pin. Isolation = 20logV<sub>COM</sub>/V<sub>NO</sub>, where V<sub>COM</sub> = output and V<sub>NO</sub> = input to off switch.

FIGURE 1. ON-RESISTANCE vs.  $V_{COM}$  (DUAL SUPPLIES)

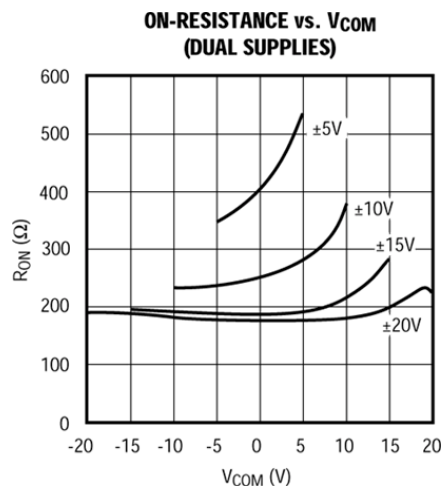

FIGURE 2. ON-RESISTANCE vs.  $V_{COM}$  OVER TEMPERATURE (DUAL SUPPLY)

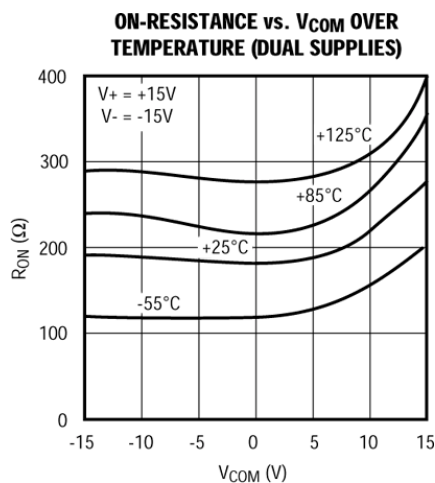

FIGURE 3. ON-RESISTANCE VS.  $V_{COM}$  OVER TEMPERATURE (SINGLE SUPPLY)

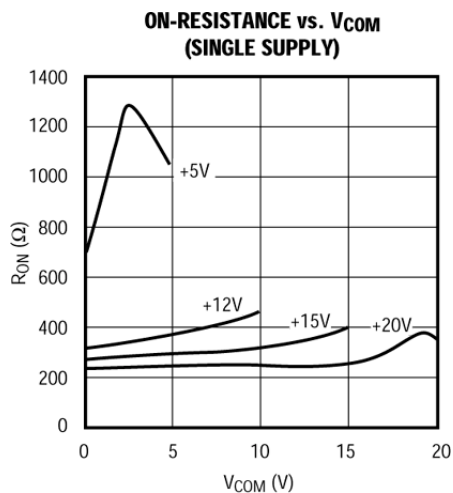

FIGURE 4. ON-RESISTANCE VS.  $V_{COM}$  OVER TEMPERATURE (SINGLE SUPPLY)

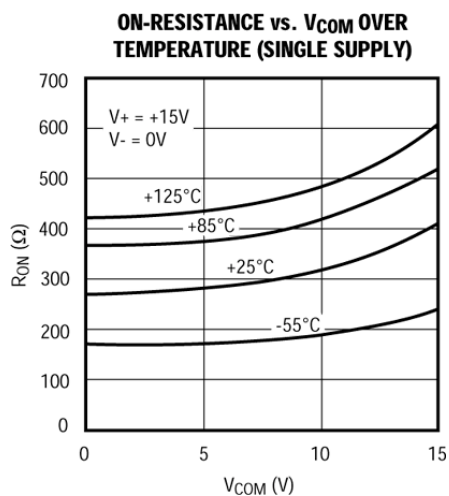

FIGURE 5. OFF LEAKAGE VS. TEMPERATURE

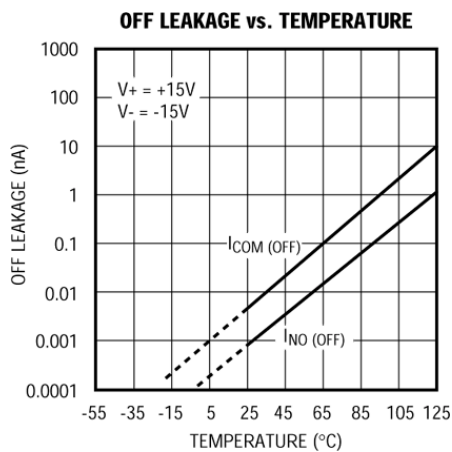

FIGURE 6. ON LEAKAGE VS. TEMPERATURE

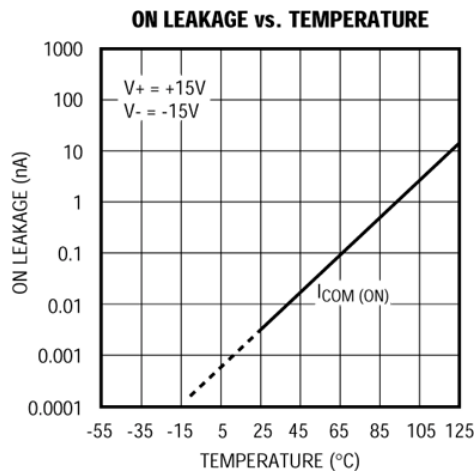

FIGURE 7. CHARGE INJECTION VS.  $V_{COM}$

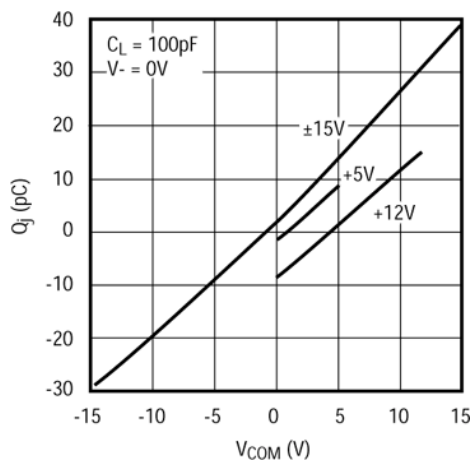

FIGURE 8. SUPPLY CURRENT VS. TEMPERATURE

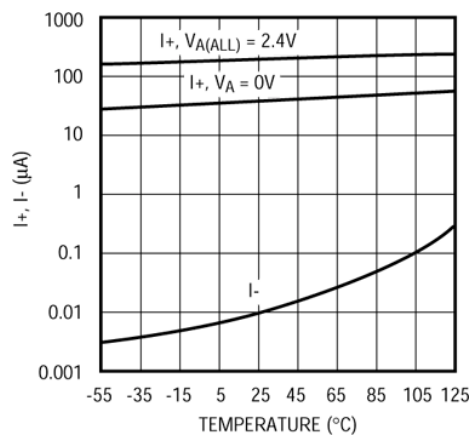

FIGURE 9. TRANSITION TIME VS. POWER SUPPLIES

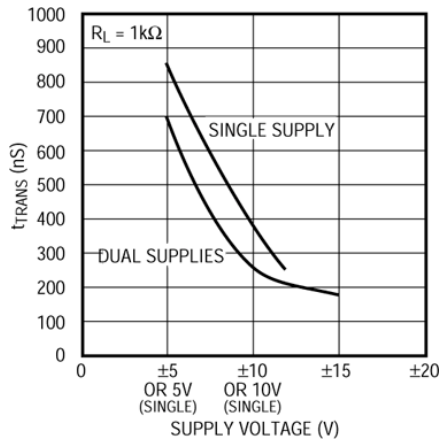

FIGURE 10. OVER VOLTAGE PROTECTION USING EXTERNAL BLOCKING DIODES

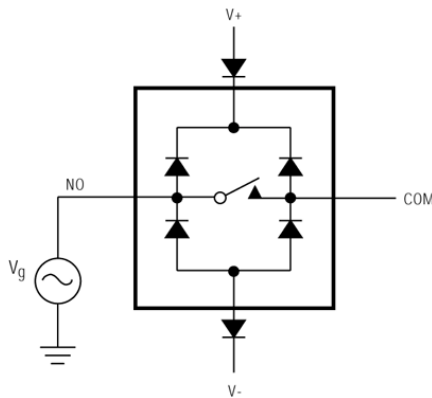

FIGURE 11. ENABLE SWITCHING TIME

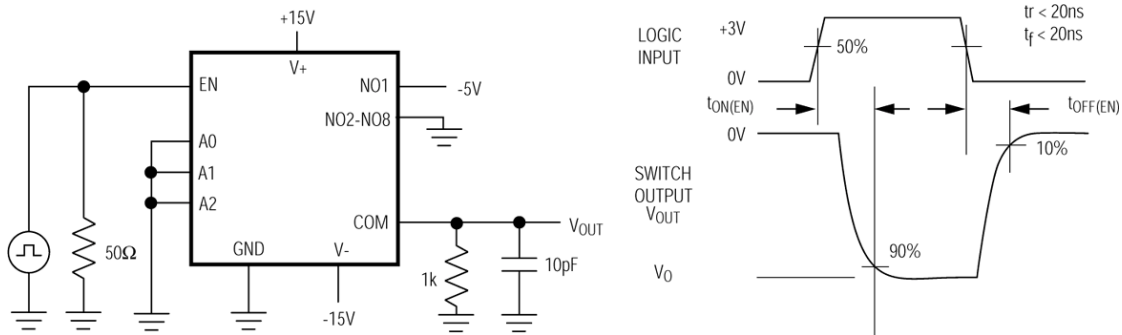

FIGURE 12. TRANSITION TIME

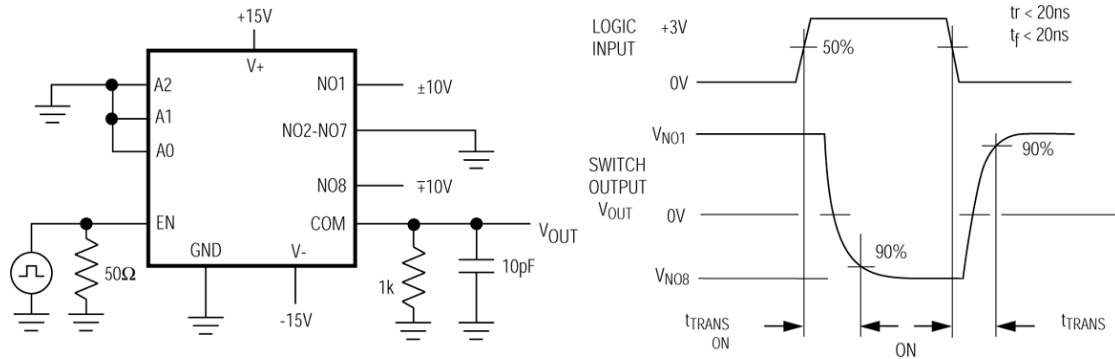

FIGURE 13. BREAK-BEFORE-MAKE INTERVAL



FIGURE 14. CHARGE INJECTION

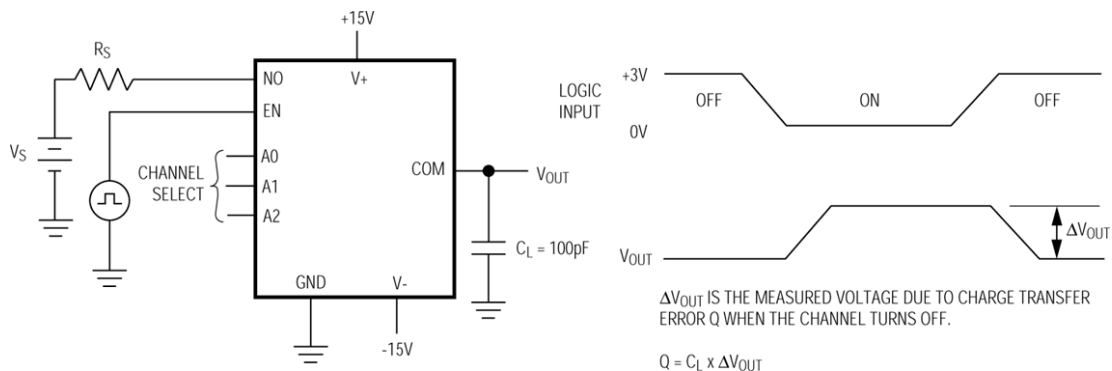

FIGURE 15. OFF ISOLATION

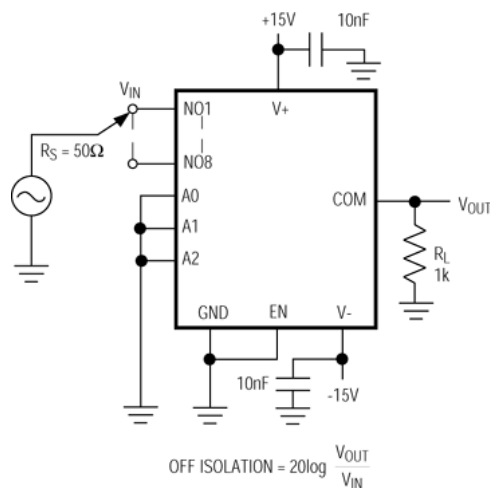

FIGURE 16. CROSSTALK

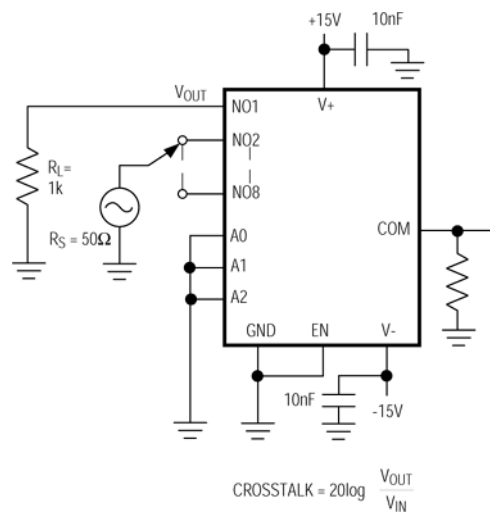

FIGURE 17. NO/COM CAPACITANCE

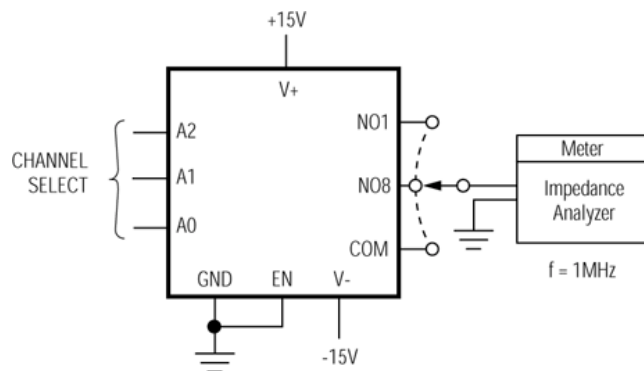
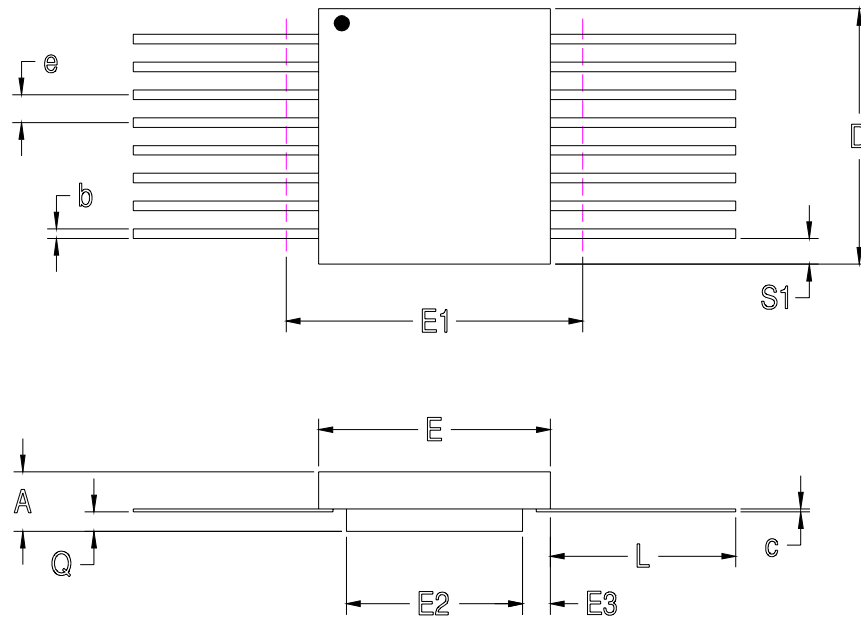

FIGURE 18. TRUTH TABLE

A2	A1	A0	EN	ON SWITCH
X	X	X	0	None
0	0	0	1	1
0	0	1	1	2
0	1	0	1	3
0	1	1	1	4
1	0	0	1	5
1	0	1	1	6
1	1	0	1	7
1	1	1	1	8

1. Logic "0"  $V_{AL} \leq 0.8V$ , Logic "1"  $V_{AH} \geq 2.4V$ .

## 16 PIN RAD-PAK® FLAT PACKAGE DIAGRAM



## 16 PIN RAD-PAK® FLAT PACKAGE

SYMBOL	DIMENSION		
	MIN	NOM	MAX
A	0.117	0.130	0.143
b	0.015	0.017	0.019
c	0.004	0.005	0.007
D	0.406	0.415	0.440
E	0.275	0.280	0.285
E1	--	--	0.500
E2	0.150	0.156	0.162
E3	0.030	0.062	--
e	0.050 BSC		
L	0.325	0.335	0.345
Q	0.020	0.033	0.045
S1	0.005	0.024	--
N	16		

F16-01

Note: All dimensions in inches

**Important Notice:**

These data sheets are created using the chip manufacturers published specifications. Maxwell Technologies verifies functionality by testing key parameters either by 100% testing, sample testing or characterization.

The specifications presented within these data sheets represent the latest and most accurate information available to date. However, these specifications are subject to change without notice and Maxwell Technologies assumes no responsibility for the use of this information.

Maxwell Technologies' products are not authorized for use as critical components in life support devices or systems without express written approval from Maxwell Technologies.

Any claim against Maxwell Technologies Inc. must be made within 90 days from the date of shipment from Maxwell Technologies. Maxwell Technologies' liability shall be limited to replacement of defective parts.

## Product Ordering Information

