

79LV2040

20 Megabit (512K x 40-Bit) Low Voltage EEPROM MCM

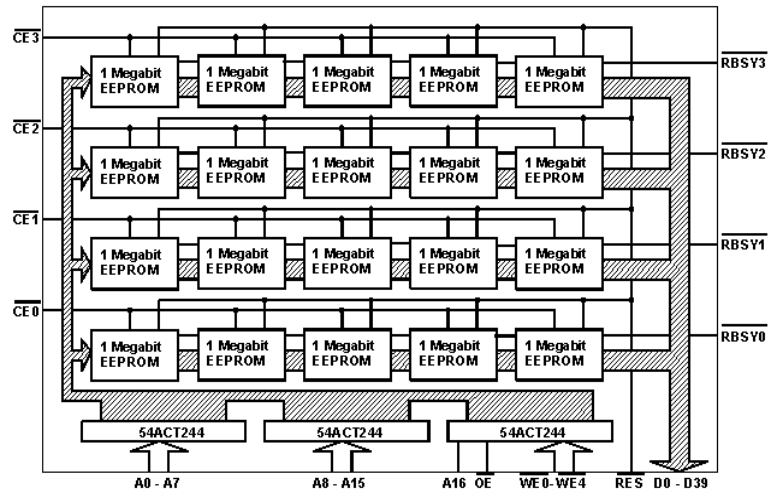
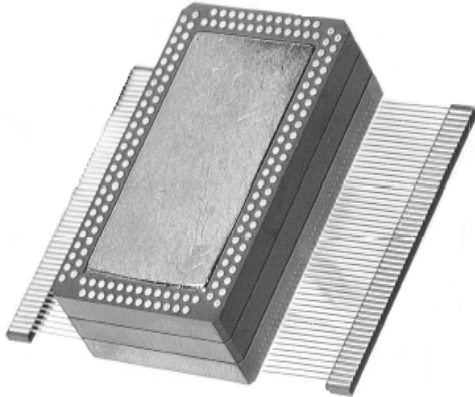

Logic Diagram

FEATURES:

- 512k x 40-bit EEPROM MCM
- RAD-PAK® radiation-hardened against natural space radiation
- Total dose hardness:
 - >100 krad (Si)
 - Dependent upon orbit
- Excellent Single event effects
 - $SEL_{TH} > 84 \text{ MeV/mg/cm}^2$
 - $SEU > 37 \text{ MeV/mg/cm}^2$ read mode
 - $SEU = 11.4 \text{ MeV/mg/cm}^2$ write mode
- High endurance
 - 10,000 cycles (Page Programming Mode)
 - 10 year data retention
- Page Write Mode: 128 Dword Page
- High Speed:
 - 200 and 250 ns maximum access times
- Automatic programming
 - 15 ms automatic Page/Dword write
- Low power dissipation
 - 100 mW/MHz active current
 - 1.5 mW standby current

DESCRIPTION:

Maxwell Technologies' 79LV2040 multi-chip module (MCM) memory features a greater than 100 krad (Si) total dose tolerance, dependent upon orbit. Using Maxwell Technologies' patented radiation-hardened RAD-PAK® MCM packaging technology, the 79LV2040 is the first radiation-hardened 8 megabit MCM EEPROM for space application. The 79LV2040 uses twenty 1 Megabit high speed CMOS die to yield a 20 megabit product. The 79LV2040 is capable of in-system electrical byte and page programmability. It has a 128 x 40 page programming function to make the erase and write operations faster. It also features Data Polling and a Ready/Busy signal to indicate the completion of erase and programming operations. In the 79LV2040, hardware data protection is provided with the RES pin, in addition to noise protection on the WE signal and write inhibit on power on and off. Software data protection is implemented using the JEDEC optional standard algorithm.

Maxwell Technologies' patented RAD-PAK® packaging technology incorporates radiation shielding in the microcircuit package. It eliminates the need for box shielding while providing the required radiation shielding for a lifetime in orbit or space mission. In a GEO orbit, RAD-PAK provides greater than 100 krad (Si) radiation dose tolerance. This product is available with screening up to Maxwell Technologies self-defined Class K

PINOUT DESCRIPTION

1	VSS	VSS	100
2	VCC	VCC	99
3	D23	D31	98
4	D22	D30	97
5	D21	D29	96
6	D20	D28	95
7	D19	D27	94
8	D18	D26	93
9	D17	D25	92
10	D16	D24	91
11	VSS	VSS	90
12	VCC	VCC	89
13	CS0	D32	88
14	CS1	D33	87
15	CS2	D34	86
16	CS3	D35	85
17	NC	D36	84
18	NC	D37	83
19	NC	D38	82
20	NC	D39	81
21	VSS	VSS	80
22	VCC	VCC	79
23	A0	A8	78
24	A1	A9	77
25	A2	A10	76
26	A3	A11	75
27	A4	A12	74
28	A5	A13	73
29	VCC	VCC	72
30	VSS	VSS	71
31	A6	A14	70
32	A7	A15	69
33	RES	A16	68
34	WE0	OE	67
35	WE1	RBSY0	66
36	WE2	RBSY1	65
37	WE3	RBSY2	64
38	WE4	RBSY3	63
39	VCC	VCC	62
40	VSS	VSS	61
41	D8	D0	60
42	D9	D1	59
43	D10	D2	58
44	D11	D3	57
45	D12	D4	56
46	D13	D5	55
47	D14	D6	54
48	D15	D7	53
49	VCC	VCC	52
50	VSS	VSS	51

1, 11, 21, 30, 40, 50, 51, 61, 71, 80, 90, 100	VSS - Ground
2, 12, 22, 29, 39, 49, 52, 62, 72, 79, 89, 99	VCC - Positive Supply
60 - 53, 41 - 48, 10 - 3, 91 - 98, 88 - 81	D0 to D39 Data I/O
13, 14, 15, 16	CS0\ - CS3\ Chip Enable
23 - 28, 31, 32, 78 -73, 70 - 68	A0 to A16 Address Inputs
33	RES\ - Reset
34 - 38	WE\0 - WE\4 Write Enables
66 - 63	RBSY\0 - RBSY\3 Ready/Busy
67	OE\ - Output Enable

TABLE 1. 79LV2040 ABSOLUTE MAXIMUM RATINGS

PARAMETER	SYMBOL	MIN	TYP	MAX	UNIT
Supply Voltage	V_{CC}	-0.6		7.0	V
Input Voltage	V_{IN}	-0.5 ¹		7.0	V
Package Weight	RSP		35		Grams
Operating Temperature Range	T_{OPR}	-55		125	°C
Storage Temperature Range	T_{STG}	-65		150	°C

1. V_{IN} min = -3.0V for pulse width ≤ 50 ns.

TABLE 2. 79LV2040 RECOMMENDED DC OPERATING CONDITIONS

PARAMETER	SYMBOL	MIN	MAX	UNIT
Supply Voltage	V_{CC}	3.0	3.6	V
Input Voltage	V_{IL}	-0.3 ¹	0.8	V
	V_{IH}	2.2	$V_{CC} + 0.3$	V
$\overline{RES_PIN}$	V_H	$V_{CC} - 0.5$	$V_{CC} + 1$	V
Operating Temperature Range	T_{OPR}	-55	125	°C

1. V_{IL} min = -1.0V for pulse width ≤ 50 ns

TABLE 3. 79LV2040 DELTA LIMITS¹

PARAMETER	VARIATION ²
I_{CC1A}	+/- 10 %
I_{CC1B}	+/- 10 %
I_{CC2A}	+/- 10 %
I_{LI} - ADDR, CE, OE, WE	+/- 10 %
I_{LI} - D0-D39	+/- 10 %

1. Parameters are measured and recorded per MIL-STD-883 for Class K devices

2. Specified value in Table 5

TABLE 4. 79LV2040 CAPACITANCE

($T_A = 25^\circ\text{C}$, $f = 1\text{ MHz}$)

PARAMETER	SYMBOL	MIN	MAX	UNIT
Input Capacitance : $V_{IN} = 0V^1$	$C_{IN\ OE}$		6	pF
	$C_{IN\ WE}$		6	
	$C_{IN\ CE_{0-30}}$		30	
	$C_{IN\ A0-A16}$		6	
	$C_{IN\ RES}$		120	
Output Capacitance: $V_{OUT} = 0V^1$	$C_{Out\ RDY/BSY}$		60	pF
	$C_{Out\ D0-D39}$	--	48	

1. Guaranteed by design.

TABLE 5. 79LV2040 DC ELECTRICAL CHARACTERISTICS

($V_{CC} = 3.3V \pm 10\%$, $T_A = -55\text{ TO }+125^\circ\text{C}$)

PARAMETER	TEST CONDITION	SYMBOL	SUBGROUPS	MIN	MAX	UNITS
Input Leakage Current A0-A16, WE, OE	$V_{IN} = V_{CC} \text{ \& } 0V$	I_{LI}	1, 2, 3	--	1 ¹	μA
	$V_{IN} = V_{CC} \text{ \& } 0V$				10	mA
Input Leakage Current D0-D39	$V_{IN} = V_{CC} \text{ \& } 0V$	I_{LI}	1, 2, 3		8	μA
Output Leakage Current	($V_{CC} = 5.5V$, $V_{OUT} = 5.5V/0.4V$)	I_{LO}	1, 2, 3	--	8	μA
Standby V_{CC} Current	$CE = ADDR=WE=OE = V_{CC}$	I_{CC1A}	1, 2, 3	--	640	μA
	$CE = V_{IH}$; $ADDR=WE=OE = V_{CC}$	I_{CC1B}			21	mA
Operating V_{CC} Current ^{1,2}	$OE = 0V$ $ADDR=WE=V_{CC}$ $I_{OUT} = 0mA$, \overline{CE} Duty = 100%, Cycle = 1 μs at $V_{CC} = 5.5V$	I_{CC2A}	1, 2, 3		30	mA
	$OE = ADDR=WE=0V$ $I_{OUT} = 0mA$, \overline{CE} Duty = 100%, Cycle = 150 ns at $V_{CC} = 5.5V$	I_{CC2D}	1, 2, 3		75	mA
Input Voltage		V_{IL}	1, 2, 3		0.8	V
		V_{IH}		2.2		
Output Voltage ³	Data Lines: V_{CC} Min, $I_{OL} = 2.1mA$	V_{OL}	1, 2, 3	--	0.4	V
	Data Lines: V_{CC} Min, $I_{OH} = -400\mu\text{A}$	V_{OH}		2.4	--	V
	All Outputs: V_{CC} Min, $I_{OH} = -100\mu\text{A}$	V_{OH}		$V_{CC} - 0.3V$	--	V

1. For RES III=2000uA max.

2. Only one Chip EnableActive (Logic Low)

3. \overline{RBSY} is an open drain output. Only V_{OL} applies to this pin.

TABLE 6. 79LV2040 AC ELECTRICAL CHARACTERISTICS FOR READ OPERATION ¹

($V_{CC} = 3.3V \pm 10\%$, $T_A = -55$ TO $+125^\circ C$)

PARAMETER	SYMBOL	SUBGROUPS	MIN	MAX	UNIT
Address Access Time $\overline{CE} = \overline{OE} = V_{IL}, \overline{WE} = V_{IH}$ -200 -250	t_{ACC}	9, 10, 11	-- --	200 250	ns
Chip Enable Access Time $\overline{OE} = V_{IL}, \overline{WE} = V_{IH}$ -200 -250	t_{CE}	9, 10, 11	-- --	200 250	ns
Output Enable Access Time $\overline{CE} = V_{IL}, \overline{WE} = V_{IH}$ -200 -250	t_{OE}	9, 10, 11	0 0	110 120	ns
Output Hold to Address Change $\overline{CE} = \overline{OE} = V_{IL}, \overline{WE} = V_{IH}$ -200 -250	t_{OH}	9, 10, 11	0 0	-- --	ns
Output Disable to High-Z ² $\overline{CE} = V_{IL}, \overline{WE} = V_{IH}$ -200 -250	t_{DF}	9, 10, 11	0 0	50 50	ns
$\overline{CE} = \overline{OE} = V_{IL}, \overline{WE} = V_{IH}$ -200 -250	t_{DFR}		0 0	300 350	ns
RES to Output Delay $\overline{CE} = \overline{OE} = V_{IL}, \overline{WE} = V_{IH}$ ³ -200 -250	t_{RR}	9, 10, 11	0 0	525 600	ns

1. Test conditions: input pulse levels = 0.4V to 2.4V; input rise and fall times ≤ 20 ns; output load = 1 TTL gate + 100 pF (including scope and jig); reference levels for measuring timing = 0.8 V/1.8 V.
2. t_{DF} and t_{DFR} are defined as the time at which the output becomes an open circuit and data is no longer driven.
3. Guaranteed by design.

TABLE 7. 79LV2040 AC ELECTRICAL CHARACTERISTICS FOR WRITE OPERATION

($V_{CC} = 3.3V \pm 10\%$, $T_A = -55$ TO $+125^\circ C$)

PARAMETER	SYMBOL	SUBGROUPS	MIN ¹	MAX	UNITS
Address Setup Time -150 -200	t_{AS}	9, 10, 11	0 0	-- --	ns
Chip Enable to Write Setup Time (\overline{WE} controlled) -150 -200	t_{CS}	9, 10, 11	0 0	-- --	ns

TABLE 7. 79LV2040 AC ELECTRICAL CHARACTERISTICS FOR WRITE OPERATION

($V_{CC} = 3.3V \pm 10\%$, $T_A = -55$ TO $+125^\circ C$)

PARAMETER	SYMBOL	SUBGROUPS	MIN ¹	MAX	UNITS
Write Pulse Width CE controlled -200 -250	t_{CW}	9, 10, 11	200 250	-- --	ns
WE controlled -200 -250	t_{WP}		200 250	-- --	ns
Address Hold Time -200 -250	t_{AH}	9, 10, 11	125 125	-- --	ns
Data Setup Time -200 -250	t_{DS}	9, 10, 11	100 150	-- --	ns
Data Hold Time -200 -250	t_{DH}	9, 10, 11	10 10	-- --	ns
Chip Enable Hold Time (\overline{WE} controlled) -200 -250	t_{CH}	9, 10, 11	0 0	-- --	ns
Write Enable to Write Setup Time (\overline{CE} controlled) -200 -250	t_{WS}	9, 10, 11	0 0	-- --	ns
Write Enable Hold Time (\overline{CE} controlled) -200 -250	t_{WH}	9, 10, 11	0 0	-- --	ns
Output Enable to Write Setup Time -200 -250	t_{OES}	9, 10, 11	0 0	-- --	ns
Output Enable Hold Time -200 -250	t_{OEH}	9, 10, 11	0 0	-- --	ns
Write Cycle Time ² -200 -250	t_{WC}	9, 10, 11	-- --	15 15	ms
Data Latch Time -200 -250	t_{DL}	9, 10, 11	700 750	-- --	ns
Byte Load Window -200 -250	t_{BL}	9, 10, 11	100 100	-- --	μs
Byte Load Cycle -200 -250	t_{BLC}	9, 10, 11	1 1	30 30	μs

TABLE 7. 79LV2040 AC ELECTRICAL CHARACTERISTICS FOR WRITE OPERATION

($V_{CC} = 3.3V \pm 10\%$, $T_A = -55$ TO $+125^\circ C$)

PARAMETER	SYMBOL	SUBGROUPS	MIN ¹	MAX	UNITS
Time to Device Busy -200 -250	t_{DB}	9, 10, 11	100 120	-- --	ns
Write Start Time ³ -200 -250	t_{DW}	9, 10, 11	150 250	-- --	ns
RES to Write Setup Time ⁴ -200 -250	t_{RP}	9, 10, 11	100 100	-- --	μs
V_{CC} to RES Setup Time ⁴ -200 -250	t_{RES}	9, 10, 11	1 1	-- --	μs

1. Use this device in a longer cycle than this value.
2. t_{WC} must be longer than this value unless polling techniques or $\overline{RDY}/\overline{BUSY}$ are used. This device automatically completes the internal write operation within this value.
3. Next read or write operation can be initiated after t_{DW} if polling techniques or $\overline{RDY}/\overline{BUSY}$ are used.
4. Guaranteed by design.

TABLE 8. 79LV2040 MODE SELECTION ¹

PARAMETER	\overline{CE} ²	\overline{OE}	\overline{WE}	I/O	\overline{RES}	$\overline{RDY}/\overline{BUSY}$
Read	V_{IL}	V_{IL}	V_{IH}	D_{OUT}	V_H	High-Z
Standby	V_{IH}	X	X	High-Z	X	High-Z
Write	V_{IL}	V_{IH}	V_{IL}	D_{IN}	V_H	High-Z --> V_{OL}
Deselect	V_{IL}	V_{IH}	V_{IH}	High-Z	V_H	High-Z
Write Inhibit	X	X	V_{IH}	--	X	--
	X	V_{IL}	X	--	X	--
Data Polling	V_{IL}	V_{IL}	V_{IH}	Data Out ³	V_H	V_{OL}
Program Reset	X	X	X	High-Z	V_L	High-Z

1. Refer to the recommended DC operating conditions.
2. For \overline{CE}_{0-3} only one \overline{CE} can be used ("on") at a time.
3. Bits 7, 15, 23, 31 and 39

FIGURE 1. READ TIMING WAVEFORM

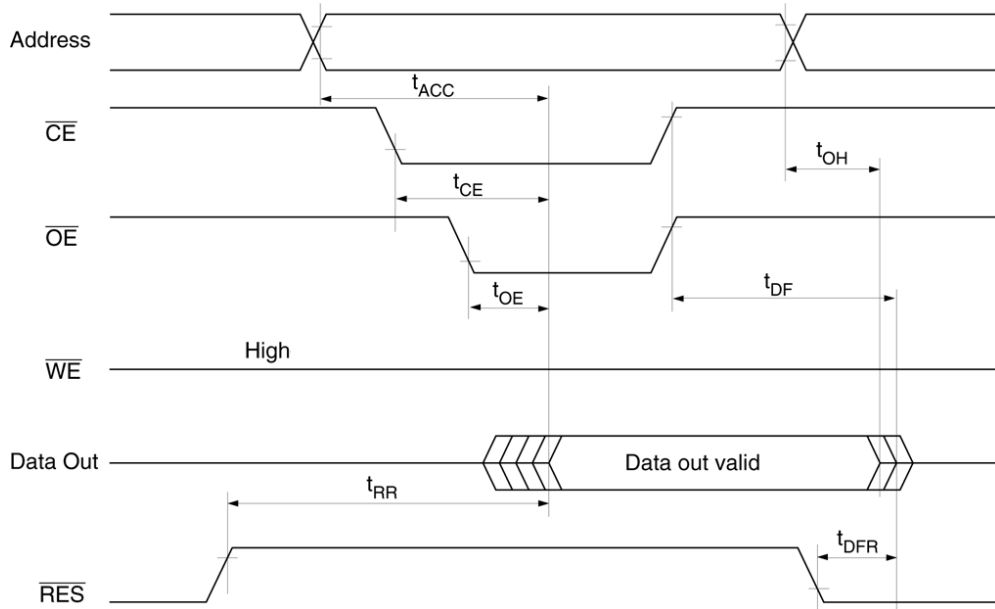

FIGURE 2. BYTE WRITE TIMING WAVEFORM (1) (\overline{WE} CONTROLLED)

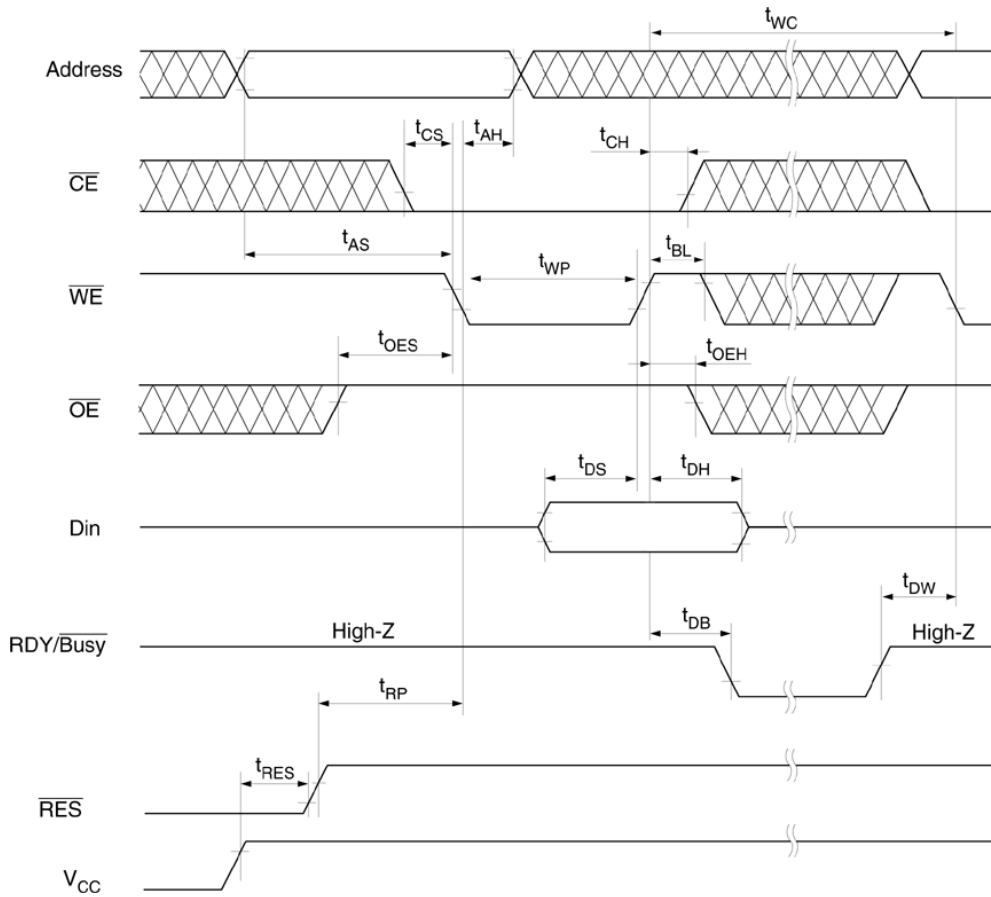

FIGURE 3. BYTE WRITE TIMING WAVEFORM (2) (\overline{CE} CONTROLLED)

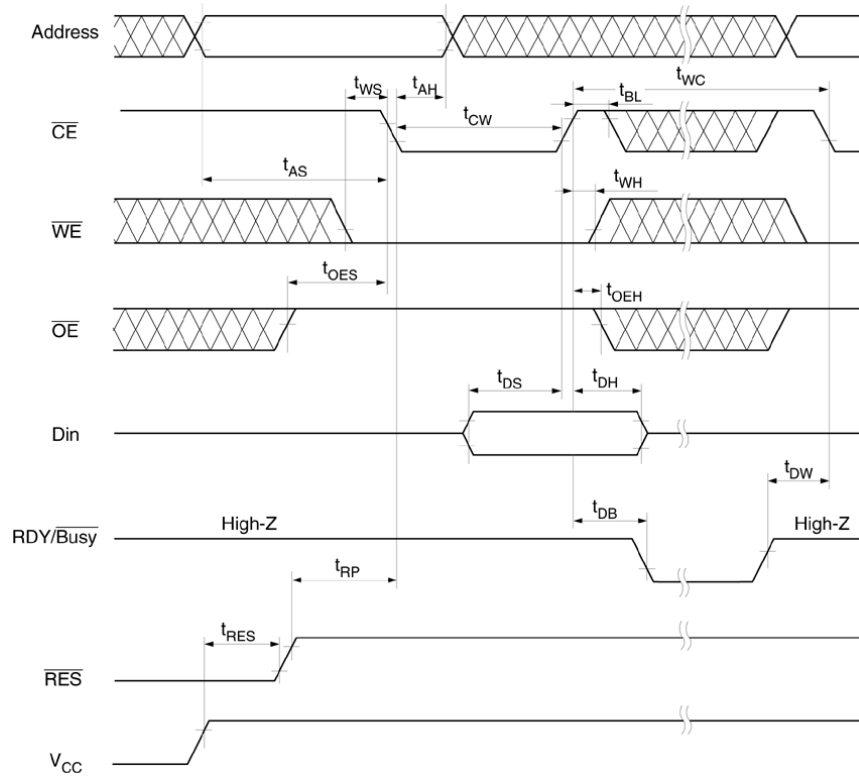
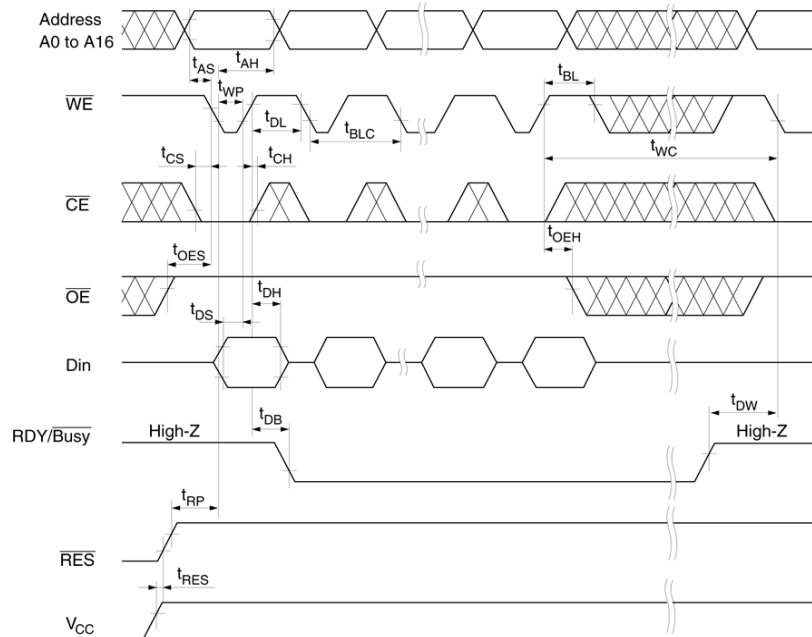
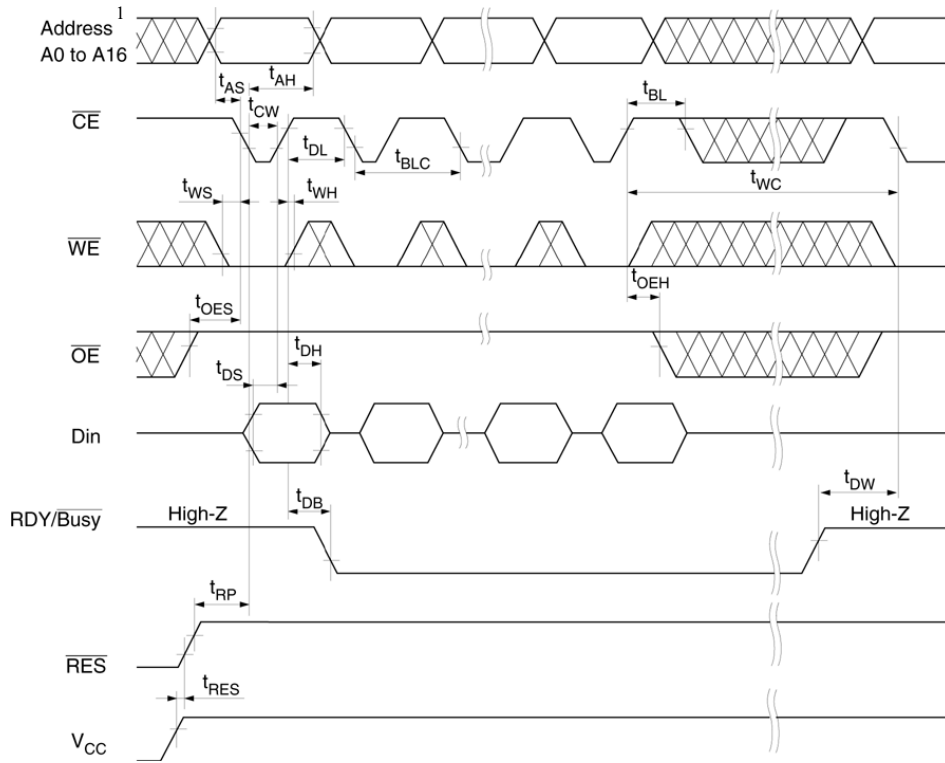

FIGURE 4. PAGE WRITE TIMING WAVEFORM (1) (\overline{WE} CONTROLLED)



1) A7-A16 are Page Addresses and must be the same within a Page Write Operation.

FIGURE 5. PAGE WRITE TIMING WAVEFORM (2) (\overline{CE} CONTROLLED)



1) A7-A16 are Page Addresses and must be the same within a Page Write Operation.

FIGURE 6. DATA POLLING TIMING WAVEFORM

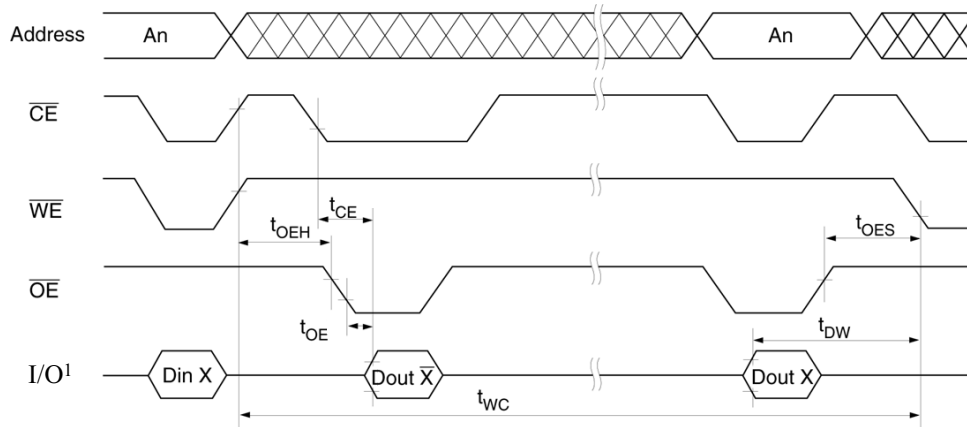

1) BITS 7, 15, 23, 31 AND 39

FIGURE 7. SOFTWARE DATA PROTECTION TIMING WAVEFORM (1) (IN PROTECTION MODE)

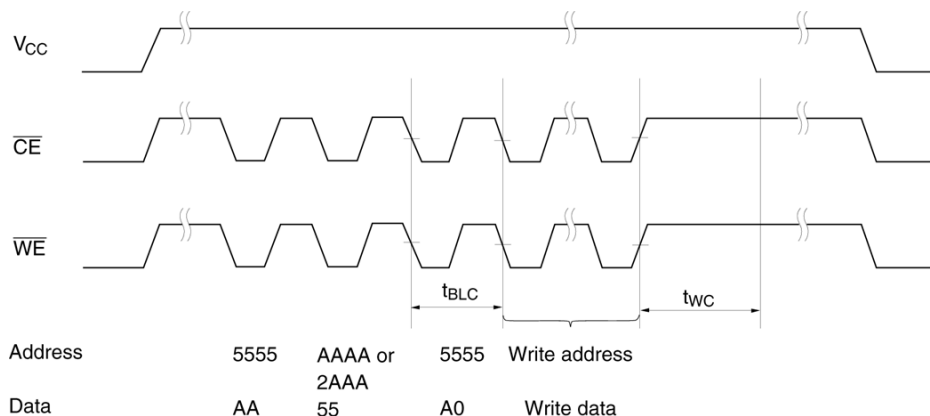
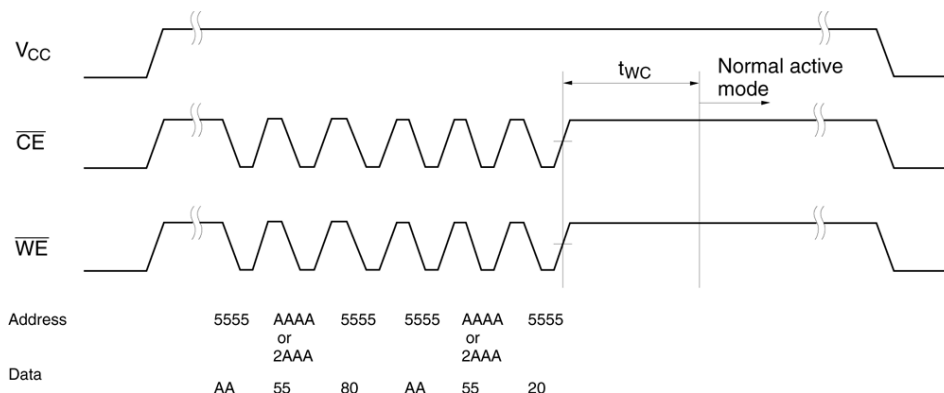

FIGURE 8. SOFTWARE DATA PROTECTION WAVEFORM (2) (IN NON-PROTECTION MODE)



EEPROM APPLICATION NOTES

This application note describes the programming procedures for the EEPROM modules and with details of various techniques to preserve data integrity.

Automatic Page Write

Page-mode write feature allows 1 to 128 bytes of data to be written into the EEPROM in a single write cycle. Loading the first byte of data, the data load window opens 30µs for the second byte. In the same manner each additional byte of data can be loaded within 30µs of the preceding falling edge of either WE or CE. When CE and WE are kept high for 100µs after data input, the EEPROM enters the write mode automatically and the data input is written into the EEPROM.

WE, CE Pin Operation

During a write cycle, addresses are latched by the falling edge of WE or CE, and data is latched by the rising edge of WE or CE.

Data Polling

Data Polling function allows the status of the EEPROM to be determined. If EEPROM is set to read mode during a write cycle, an inversion of the last byte of data to be loaded outputs from I/O 7 to indicate that the EEPROM is performing a write operation.

RDY/Busy Signal

RDY/Busy signal also allows a comparison operation to determine the status of the EEPROM. The RDY/Busy signal goes low (V_{OL}) after the first write signal. At the end of the write cycle, the RDY/Busy returns to a high state (V_{OH}).

RES Signal

When RES is LOW (V_L), the EEPROM cannot be read or programmed. The EEPROM data must be protected by keeping RES low when V_{CC} is power on and off. RES should be high (V_H) during read and programming operations.

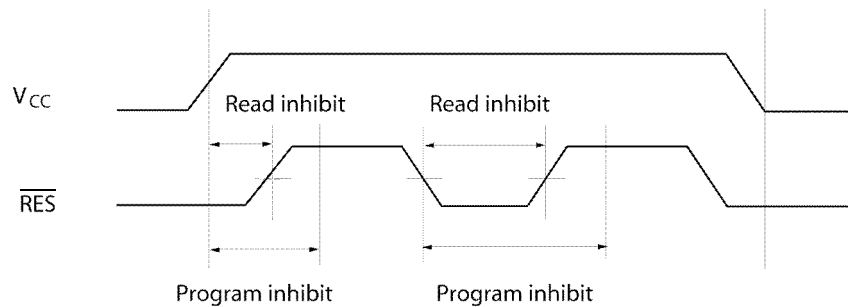

Data Protection

To protect the data during operation and power on/off, the EEPROM has the internal functions described below.

1. Data Protection against Noise of Control Pins (\overline{CE} , \overline{OE} , \overline{WE}) during Operation.

During readout or standby, noise on the control pins may act as a trigger and turn the EEPROM to programming mode by mistake. To prevent this phenomenon, the EEPROM has a noise cancellation function that cuts noise if its width is 20ns or less in programming mode. Be careful not to allow noise of a width more than 20ns on the control pins.

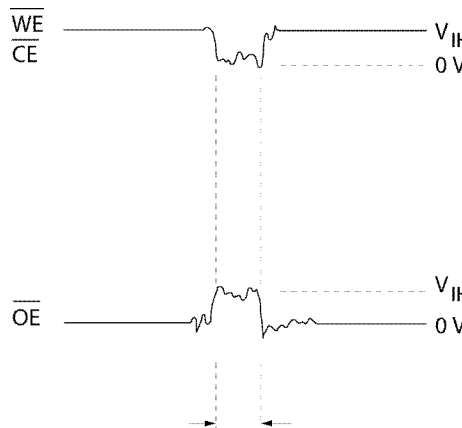

2. Data Protection at V_{CC} on/off

When V_{CC} is turned on or off, noise on the control pins generated by external circuits, such as CPUs, may turn the EEPROM to programming mode by mistake. To prevent this unintentional programming, the EEPROM must be kept in unprogrammable state during V_{CC} on/off by using a CPU reset signal to \overline{RES} pin.

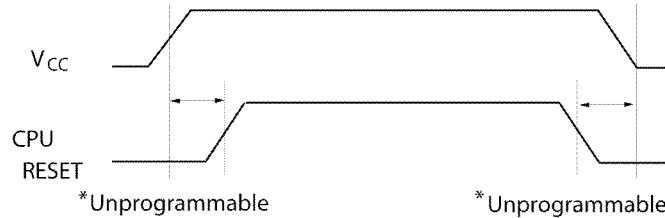

3. \overline{RES} Signal

\overline{RES} should be kept at V_{SS} level when V_{CC} is turned on or off. The EEPROM breaks off programming operation when \overline{RES} become low, programming operation doesn't finish correctly in case that \overline{RES} falls low during programming operation. \overline{RES} should be kept high for 10 ms after the last data is input

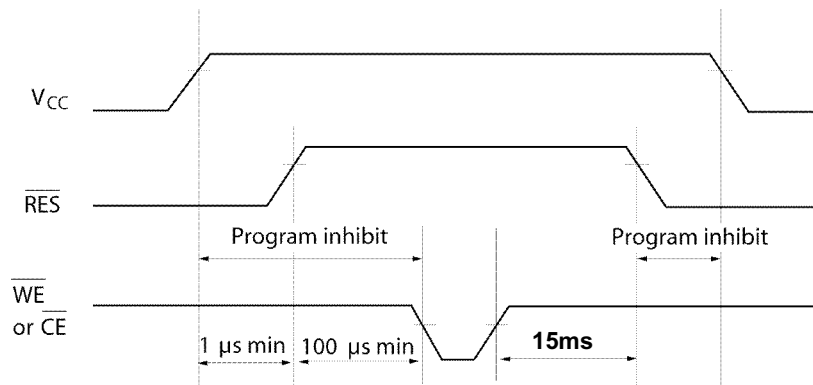

4. Software Data Protection Enable

The 79LV2040 contains a software controlled write protection feature that allows the user to inhibit all write operations to the device. This is useful in protecting the device from unwanted write cycles due to uncontrollable circuit noise or inadvertent writes caused by minor bus contentions. Software data protection is enabled by writing the following data sequence to the EEPROM and allowing the write cycle period (t_{WC}) of 15ms to elapse:

Software Data Protection Enable Sequence

Address	Data
5555	AA AA AA AA AA
AAAA or 2AAA	55 55 55 55 55
5555	A0 A0 A0 A0 A0

5. Writing to the Memory with Software Data Protection Enabled

To write to the device once Software protection is enabled, the enable sequence must precede the data to be written. This sequence allows the write to occur while at the same time keeping the software protection enabled

Sequence for Writing Data with Software Protection Enabled.

Address	Data
5555	AA AA AA AA AA
AAAA or 2AAA	55 55 55 55 55
5555	A0 A0 A0 A0 A0
Write Address(s)	Normal Data Input

6. Disabling Software Protection

Software data protection mode can be disabled by inputting the following 6 bytes sequence. Once the software protection sequence has been written, no data can be written to the memory until the write cycle (T_{WC}) has elapsed.

Software Protection Disable Sequence

Address	Data
5555	AA AA AA AA AA
AAAA or 2AAA	55 55 55 55 55
5555	80 80 80 80 80
5555	AA AA AA AA AA
AAAA or 2AAA	55 55 55 55 55
5555	20 20 20 20 20

Devices are shipped in the “unprotected” state, meaning that the contents of the memory can be changed as required by the user. After the software data protection is enabled, the device enters the Protect Mode where no further write commands have any effect on the memory contents.

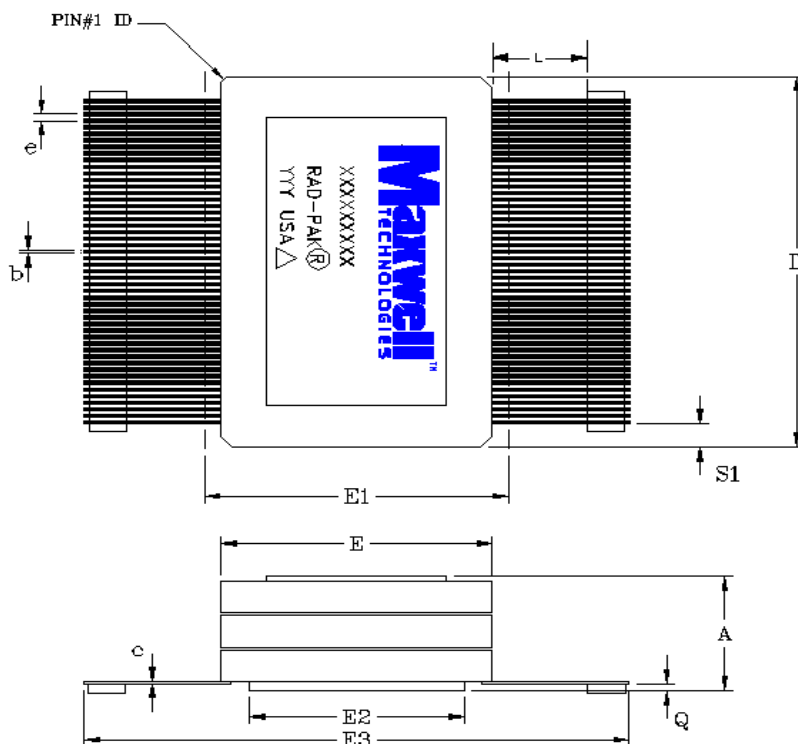

100 PIN STACKED FLAT PACKAGE

SYMBOL	DIMENSION		
	MIN	NOM	MAX
A	.400	.448	.500
b	.006	.008	.010
c	.006	.008	.010
D	1.346	1.366	1.388
E	.882	.897	.912
E1	--	--	.950
E2	.702	.708	--
E3	1.825	1.900	--
e	0.025BSC		
L	.330	.340	.350
Q	.013	.018	.023
S1	.005	.075	--
N	100		

Note: All dimensions in inches

Important Notice:

These data sheets are created using the chip manufacturers published specifications. Maxwell Technologies verifies functionality by testing key parameters either by 100% testing, sample testing or characterization.

The specifications presented within these data sheets represent the latest and most accurate information available to date. However, these specifications are subject to change without notice and Maxwell Technologies assumes no responsibility for the use of this information.

Maxwell Technologies' products are not authorized for use as critical components in life support devices or systems without express written approval from Maxwell Technologies.

Any claim against Maxwell Technologies must be made within 90 days from the date of shipment from Maxwell Technologies. Maxwell Technologies' liability shall be limited to replacement of defective parts.

Product Ordering Options

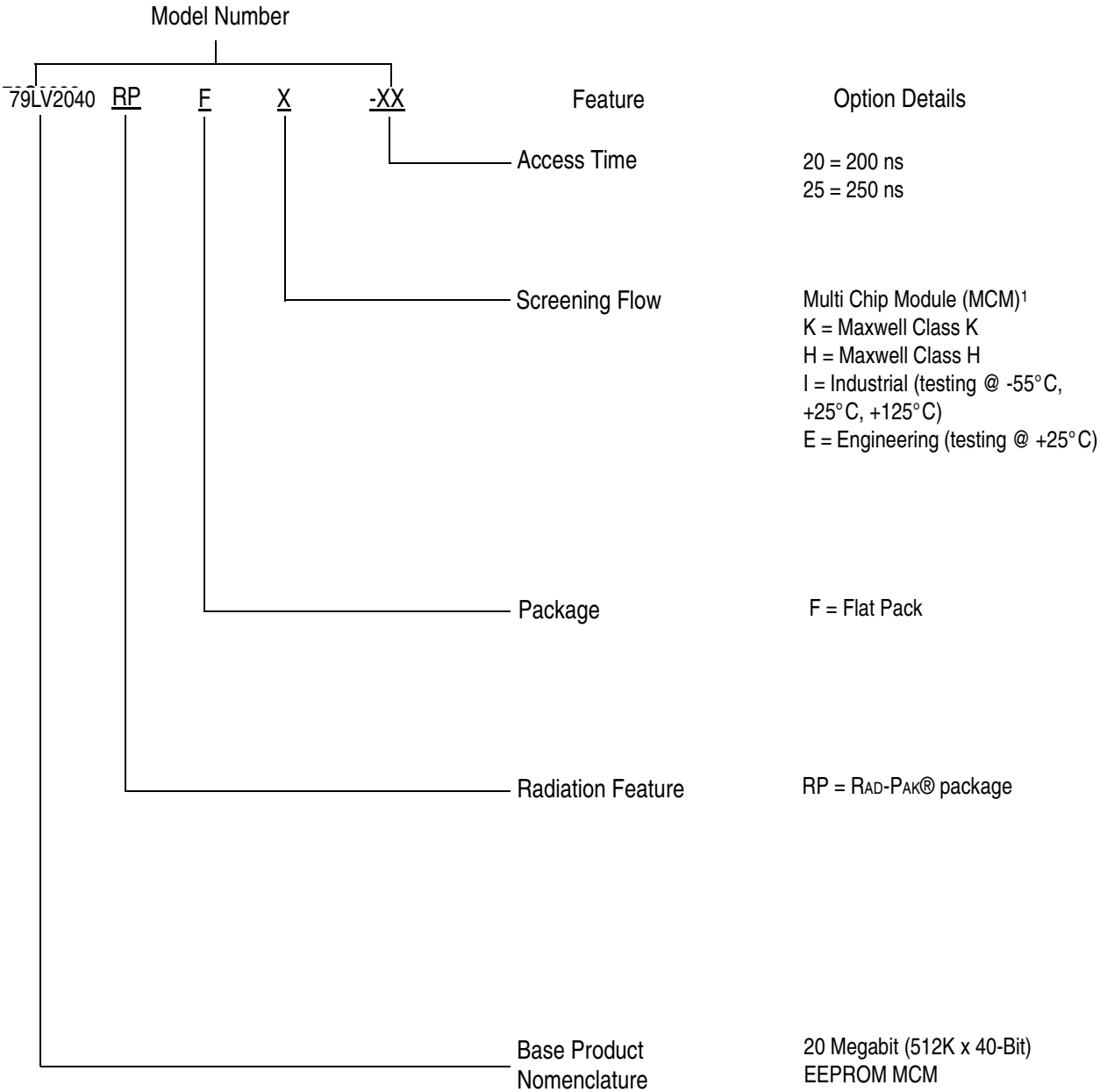

1) Products are manufactured and screened to Maxwell Technologies self-defined Class H and Class K flows.