

### FEATURES:

- Total dose hardness:
  - > 300 krad (Si)
  - SEL > 120 MeV-cm<sup>2</sup>/mg
- 41 MSPS minimum sampling rate
- 80 dB Spurious-Free Dynamic Range (SFDR)
- Package:
  - 28 pin RAD-PAK® flat pack
- 595 mW power dissipation
- Single 5 volt power supply
- On-chip T/H and reference
- Two's complement output format
- CMOS compatible output levels

### DESCRIPTION:

Maxwell Technologies' 9042 12-Bit analog-to-digital converter features a greater than 300 krad (Si) total dose tolerance. Using Maxwell's radiation-hardened RAD-PAK® packaging technology, the 9042 realizes a higher performance, and low power consumption. All necessary functions, including track-and-hold (T/H) and reference are included on chip to provide a complete conversion solution. The 9042 runs off of a single +5V supply and provides CMOS-compatible digital outputs at 41 MSPS. Designed specifically to address the needs of wide-band, multichannel receivers, the 9042 maintains 80 dB spurious-free dynamic range (SFDR) over a bandwidth of 20 MHz. Noise performance is also exceptional; typical signal to noise ratio is 68 dB.

Maxwell Technologies' patented RAD-PAK® packaging technology incorporates radiation shielding in the microcircuit package. It eliminates the need for box shielding while providing the required radiation shielding for a lifetime in an orbit or space mission. This product is available with screening up to Maxwell Technologies self-defined Class K.

TABLE 1. 9042 PIN DESCRIPTION

PIN	SYMBOL	DESCRIPTION
1	GND	Ground
2	DV <sub>CC</sub>	5V Power Supply (Digital)
3	GND	Ground
4	ENCODE	Encode Input. Data conversion initiated on rising edge.
5	$\overline{\text{ENCODE}}$	Complement of ENCODE. Drive differently with ENCODE or bypass to Ground for single-ended clock mode.
6	GND	Ground
7	GND	Ground
8	AIN	Analog Input.
9	V <sub>OFFSET</sub>	Voltage Offset Input. Sets mid-point of analog input range. Normally tied to V <sub>REF</sub> through 50 Ohm resistor.
10	V <sub>REF</sub>	Internal Voltage Reference. Nominally 2.4V; normally tied to V <sub>OFFSET</sub> through 50 Ohm resistor. Bypass to Ground with 0.01 $\mu$ F capacitor.
11	GND	Ground
12	AV <sub>CC</sub>	5V Power Supply (Analog)
13	GND	Ground
14	AV <sub>CC</sub>	5V Power Supply (Analog)
15	NC	No Connects.
16	NC	No Connects.
17	D0 (LSB)	Digital Output Bit (Least Significant Bit).
18 - 27	D1 - D10	Digital Output Bits.
28	D11 (MSB) <sup>1</sup>	Digital Output Bit (Most Significant Bit).

1. Output coded as twos complement

TABLE 2. 9042 ABSOLUTE MAXIMUM RATINGS<sup>1</sup>

PARAMETER	SYMBOL	MIN	TYPICAL	MAX	UNIT
ELECTRICAL					
Analog Supply Voltage	$AV_{CC}$	0		7	V
Digital Supply Voltage	$DV_{CC}$	0		7	V
Analog Input Voltage	$A_{IN}$	0.5		4.5	V
Analog Input Current				20	mA
Digital Input Voltage (ENCODE)		0		$AV_{CC}$	V
ENCODE, ENCODE Differential Voltage				4	V
Digital Output Current		-40		40	mA
Package Weight			5.25		Grams
Thermal Impedance	$\Theta_{JC}$		2.39		°C/W
ENVIRONMENTAL					
Maximum Junction Temperature	$T_J$			150	°C
Operating Temperature Range	$T_A$	-55		125	°C
Storage Temperature Range	$T_S$	-65		150	°C

1. Absolute maximum ratings are limiting values to be applied individually, and beyond which the serviceability of the circuit may be impaired. Functional operability is not necessarily implied. Exposure to absolute maximum rating conditions for an extended period of time may affect device reliability.

TABLE 3. DELTA LIMITS

PARAMETER	VARIATION
$I(AV_{CC})$	±10% of specified value in Table 4
$I(DV_{CC})$	±10% of specified value in Table 4
$I_{CCTOTAL}$	±10% of specified value in Table 4

TABLE 4. 9042 DC ELECTRICAL CHARACTERISTICS

( $AV_{CC} = DV_{CC} = +5V \pm 5\%$ ;  $V_{REF}$  TIED TO  $V_{OFFSET}$  THROUGH  $50 \Omega$ ;  $T_A = -55^\circ C$  TO  $+125^\circ C$ )

PARAMETER	SYMBOL	CONDITION	SUBGROUPS	MIN	TYP	MAX	UNIT
Resolution					12		
DC ACCURACY							
No Missing Codes <sup>1</sup>		-55 to 125°C	1, 2, 3	Guaranteed			
Offset Error		-55 to 125°C	1, 2, 3	-10	±3	10	mV
Offset Tempco		-55 to 125°C	1, 2, 3		25		ppm/°C
Gain Error		-55 to 125°C	1, 2, 3	-6.5	0	6.5	% FS
Gain Tempco		-55 to 125°C	1, 2, 3		-50		ppm/°C
REFERENCE OUT	$V_{REF}^2$	25°C	1	2.3	2.4	2.5	V

TABLE 4. 9042 DC ELECTRICAL CHARACTERISTICS  
 ( $AV_{CC} = DV_{CC} = +5V \pm 5\%$ ;  $V_{REF}$  TIED TO  $V_{OFFSET}$  THROUGH  $50 \Omega$ ;  $T_A = -55^\circ C$  TO  $+125^\circ C$ )

PARAMETER	SYMBOL	CONDITION	SUBGROUPS	MIN	TYP	MAX	UNIT
Analog Input (AIN)							
Input Voltage Range			1, 2, 3		$V_{REF} \pm 0.5$		V
Input Resistance		-55 to 125°C	2, 3	200	250	300	$\Omega$
Input Capacitance		25°C	1		7		
ENCODE INPUTS <sup>1,3</sup>							
Logic Compatibility <sup>4</sup>					TTL/ CMOS		
Logic "1" Voltage	$V_{IH}$	-55 to 125°C	1, 2, 3	2.0		5.0	V
Logic "0" Voltage	$V_{IL}$	-55 to 125°C	1, 2, 3	0		0.8	V
Logic "1" Current ( $V_{INH} = 5V$ )	$I_{IH}$	-55 to 125°C	1, 2, 3	450	625	800	$\mu A$
Logic "0" Current ( $V_{INL} = 0V$ )	$I_{IL}$	-55 to 125°C	1, 2, 3	-400	-300	-200	$\mu A$
Input Capacitance		25°C	1		2.5		pF
DIGITAL OUTPUTS							
Logic Compatibility					CMOS		
Logic "1" Voltage ( $I_{OH} = 10 \mu A$ )	$V_{OH}$	25°C	1	3.5	4.2		V
		-55 to 125°C	1, 2, 3	3.5			
Logic "0" Voltage ( $I_{OL} = 10 \mu A$ )	$V_{OL}$	25°C, 125°C	1, 2		--	0.80	V
		-55	3			0.90	
Output Coding				Twos Compliment			
POWER SUPPLY							
Analog Supply Voltage	$AV_{CC}$	-55 to 125°C	1, 2, 3		5.0		V
Analog Supply Current	$I_{AVCC}$	-55 to 125°C	1, 2, 3		--	160	mA
Digital Supply Voltage	$DV_{CC}$	-55 to 125°C	1, 2, 3		5.0		V
Digital Supply Current	$I_{DVCC}$	-55 to 125°C	1, 2, 3		--	20	mA
Supply Current (Total)	$I_{CCTOTAL}$	-55 to 125°C	1, 2, 3		119	180	mA
Power Dissipation		-55 to 125°C	1, 2, 3		595	990	mW
Power Supply Rejection	PSRR	25°C	1	-20	$\pm 1$	20	mV/V
		-55 to 125°C	1, 2, 3		$\pm 5$		mV/V
Differential Non-linearity (ENCODE = 20 MSPS)	DNL	-55 to 125°C	1, 2, 3	-1.0	$\pm 0.3$	1.0	LSB
Integral Non-linearity (ENCODE = 20 MSPS)	INL	-55 to 125°C	1, 2, 3	-1.5	$\pm 0.75$	1.5	LSB

1. Guaranteed by design.
2.  $V_{REF}$  is normally tied to  $V_{OFFSET}$  through 50 ohms. If  $V_{REF}$  is used to provide dc offset to other circuits, it should first be buffered
3. ENCODE driven by single-ended source;  $\overline{ENCODE}$  bypassed to ground through 0.01  $\mu F$  capacitor.
4. ENCODE may also be driven differently in conjunction with  $\overline{ENCODE}$ .

TABLE 5. 9042 AC ELECTRICAL CHARACTERISTICS<sup>1</sup>(AV<sub>CC</sub> = DV<sub>CC</sub> = +5V ±5%; ENCODE & ENCODE = 41 MSPS; V<sub>REF</sub> TIED TO V<sub>OFFSET</sub> THROUGH 50 Ω; T<sub>A</sub> = -55°C TO +125°C)

PARAMETER	SYMBOL	CONDITION	SUBGROUPS	MIN	TYP	MAX	UNIT
Signal to Noise Ratio <sup>2</sup> Analog Input @ -1 dBFS	SNR						dB
1.2 MHz		25°C	4	--	68	--	
		-55 to 125°C	5, 6	--	67.5	--	
9.6 MHz		25°C	4	--	67.5	--	
		-55 to 125°C	5, 6	--	67	--	
19.5 MHz		25°C	4	64	67	--	
		-55 to 125°C	5, 6	--	66.5	--	
SINAD <sup>3</sup> Analog Input @ -1 dBFS	SINAD						dB
1.2 MHz		25°C	4	--	67.5	--	
		-55 to 125°C	5, 6	--	67	--	
9.6 MHz		25°C	4	--	67.5	--	
		-55 to 125°C	5, 6	--	67	--	
19.5 MHz		25°C	4	64	67	--	
		-55 to 125°C	5, 6	--	66.5	--	
Worst Spur <sup>4</sup> Analog Input @ -1 dBFS							dBc
1.2 MHz		25°C	4	--	80	--	
		-55 to 125°C	5, 6	--	78	--	
9.6 MHz		25°C	4	--	80	--	
		-55 to 125°C	5, 6	--	78	--	
19.5 MHz		25°C	4	73	80	--	
		-55 to 125°C	5, 6	--	78	--	
Small Signal Spurious Free Dynamic Range (w/ Dither) <sup>5</sup> Analog Input @	SFDR						dBFS
1.2 MHz		-55 to 125°C	4, 5, 6	--	90	--	
9.6 MHz				--	90	--	
19.5 MHz				--	90	--	
Two-Tone IMD Rejection <sup>6</sup> F1, F2 @ -7 dBFS		-55 to 125°C	4, 5, 6	--	80	--	dBc
Two-Tone SFDR (w/Dither) <sup>7</sup>		-55 to 125°C	4, 5, 6	--	90	--	dBFS
Thermal Noise		25°C	9	--	0.33	--	LSB rms
Analog Input bandwidth <sup>8</sup>		25°C	9		100		MHz
Transient Response <sup>8</sup>		25°C	9		10		ns
Overvoltage Recovery Time <sup>8</sup>		25°C	9		25		ns

TABLE 5. 9042 AC ELECTRICAL CHARACTERISTICS<sup>1</sup>

( $V_{CC} = DV_{CC} = +5V \pm 5\%$ ; ENCODE & ENCODE = 41 MSPS;  $V_{REF}$  TIED TO  $V_{OFFSET}$  THROUGH  $50 \Omega$ ;  $T_A = -55^\circ C$  TO  $+125^\circ C$ )

PARAMETER	SYMBOL	CONDITION	SUBGROUPS	MIN	TYP	MAX	UNIT
Maximum Conversion Rate		-55 to 125°C	9, 10, 11	41			MSPS
Minimum Conversion Rate <sup>8</sup>		-55 to 125°C	9, 10, 11			5	MSPS
Aperature Delay	$t_A$	25°C	9		-250		ps
Aperature Uncertainty	Jitter	25°C	9		0.7		ps rms
ENCODE Pulse Width High		25°C	9	10			ns
ENCODE Pulse Width Low		25°C	9	10			ns
Output Delay	$t_{OD}$	-55 to 125°C	9, 10, 11	5	9	14	ns

- All AC specifications tested by driving ENCODE and  $\overline{ENCODE}$  differentially.
- Analog input signal power at -1 dBFS; signal-to-noise ratio (SNR) is the ratio of signal level to total noise (first five harmonics removed).
- Analog input signal power at -1 dBFS; signal-to-noise and distortion (SINAD) is the ratio of signal level to total noise + harmonics.
- Analog input signal power at -1 dBFS; worst spur is the ratio of signal level to worst spur, usually limited by harmonics.
- Analog input signal power swept from -20 dBFS to -95 dBFS; dither power = -32.5 dBm; dither circuit used on input signal SFDR is ratio of converter full scale to worst spur.
- Tones at -7dBFS (F1 = 15.3 MHz, F2 = 19.5 MHz); two tone intermodulation distortion (IMD) rejection is ratio of either tone to worst third order intermod product.
- Both input tones swept from -20 to -95 dBFS; dither power = -32.5 dBm; dither circuit used on input signal two-tone spurious-free dynamic range (SFDR) is the ratio of converter full scale to worst spur.
- Guaranteed by design.

FIGURE 1. TIMING DIAGRAM

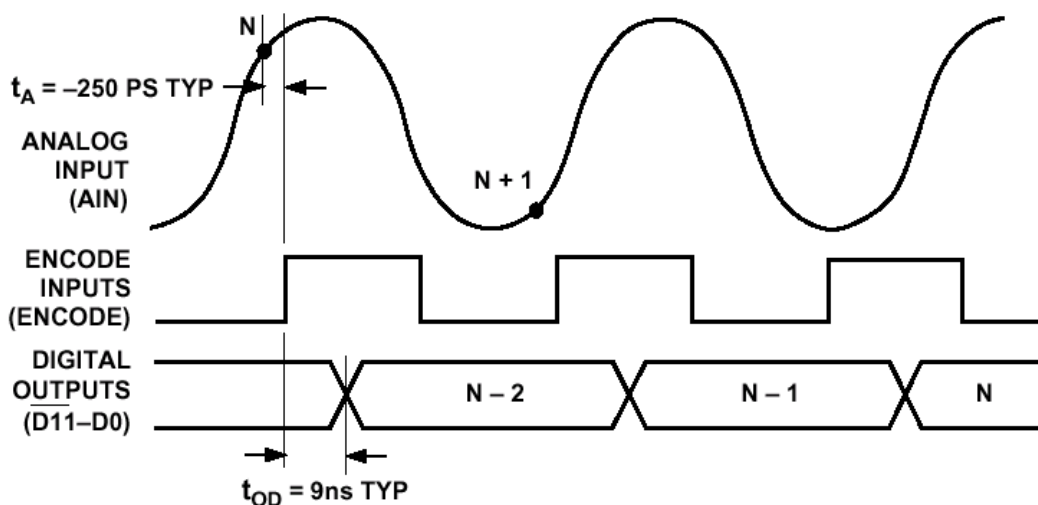

FIGURE 2. ANALOG INPUT STAGE EQUIVALENT CIRCUIT

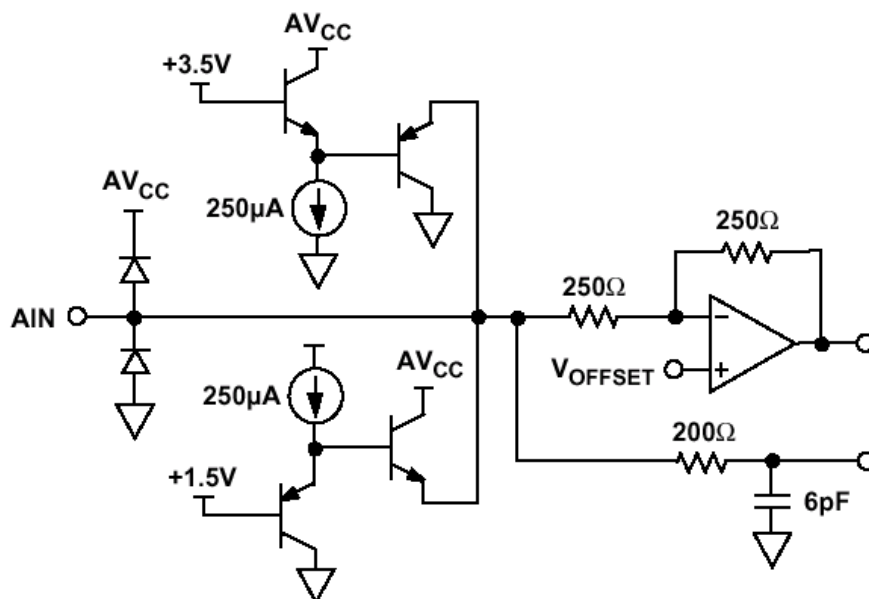

FIGURE 3. ENCODE INPUTS EQUIVALENT CIRCUIT

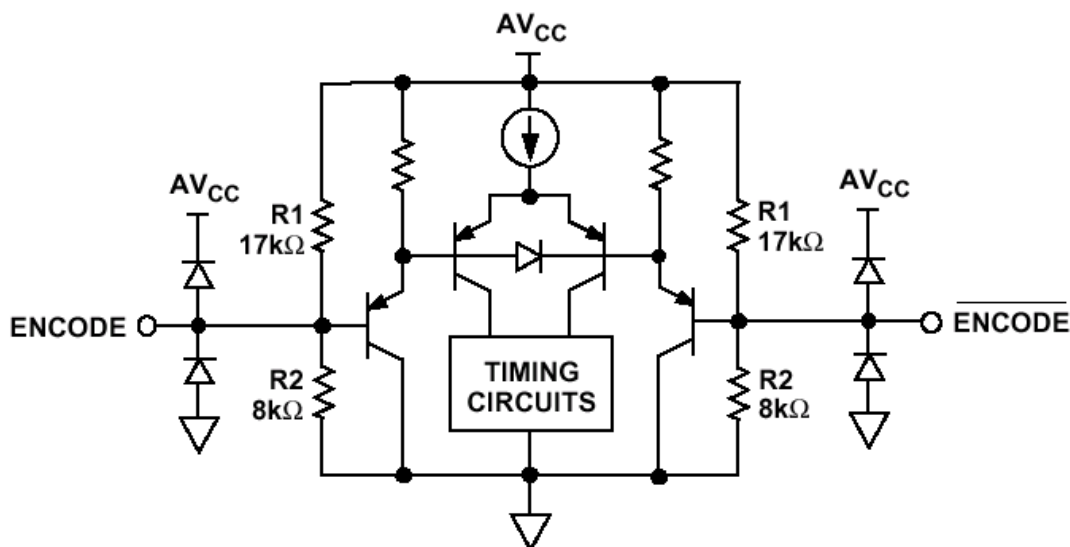

FIGURE 4. COMPENSATION PIN, C1 EQUIVALENT CIRCUIT

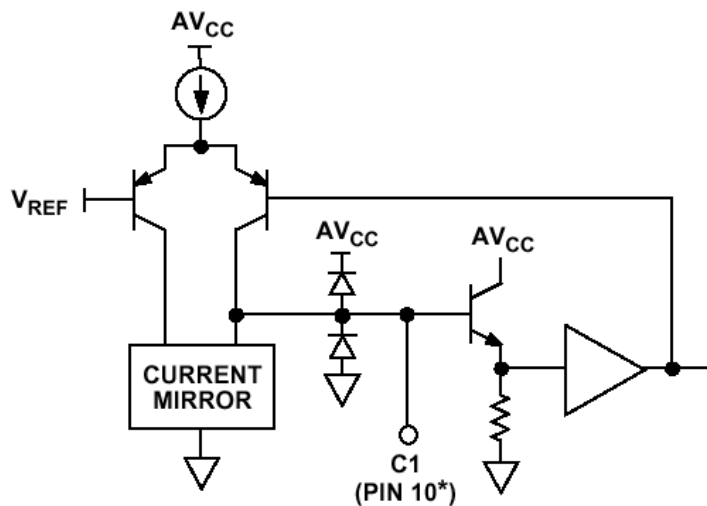

FIGURE 5. DIGITAL OUTPUT STAGE EQUIVALENT CIRCUIT

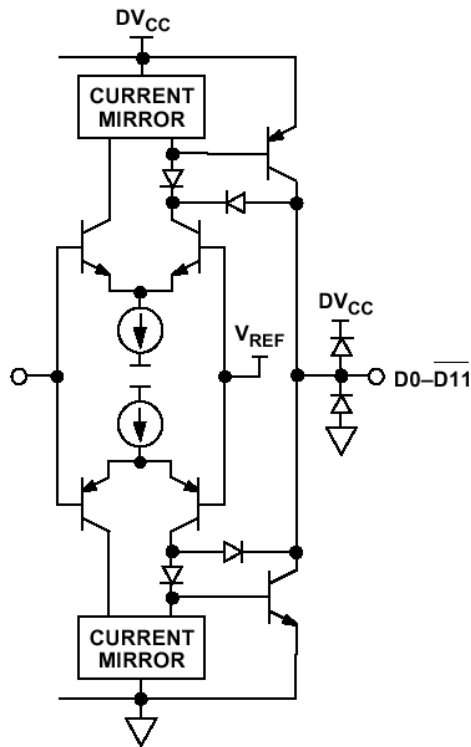

FIGURE 6. 2.4 V REFERENCE EQUIVALENT CIRCUIT

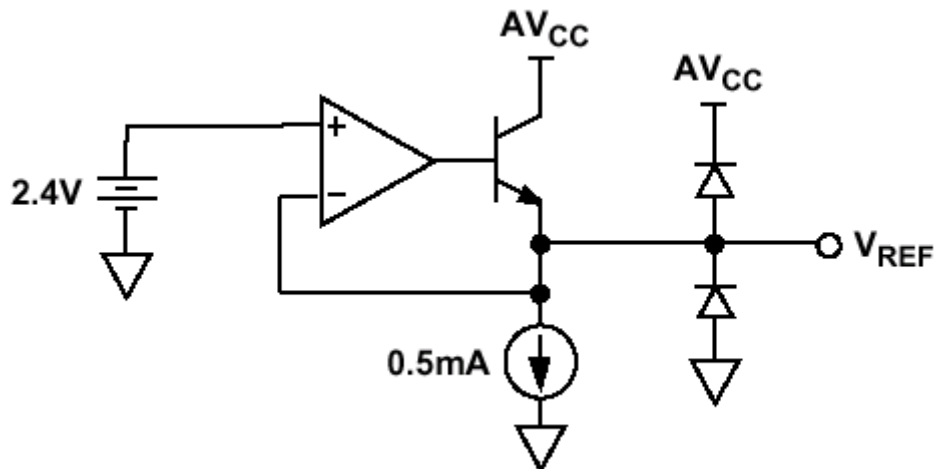

FIGURE 7. SINGLE TONE AT 1.2 MHz

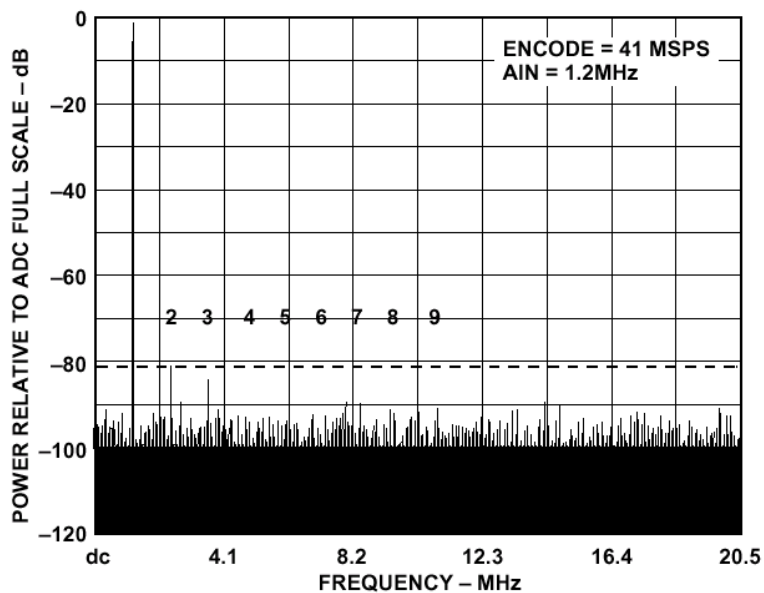

FIGURE 8. SINGLE TONE AT 9.6 MHz

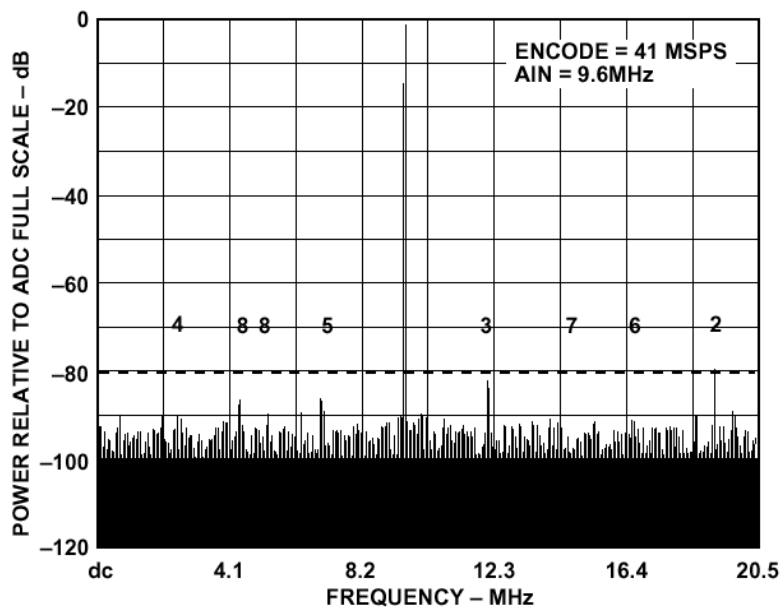

FIGURE 9. SINGLE TONE AT 19.5 MHz

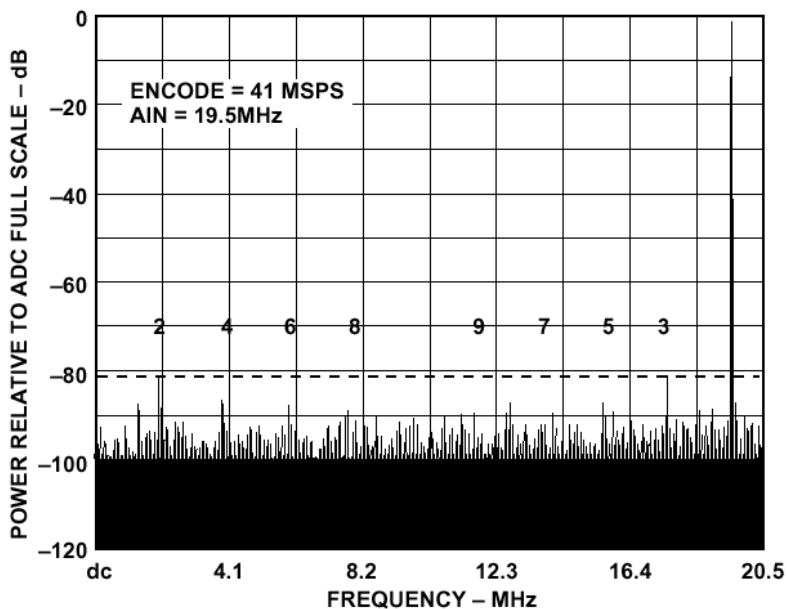

FIGURE 10. HARMONICS VS. AIN

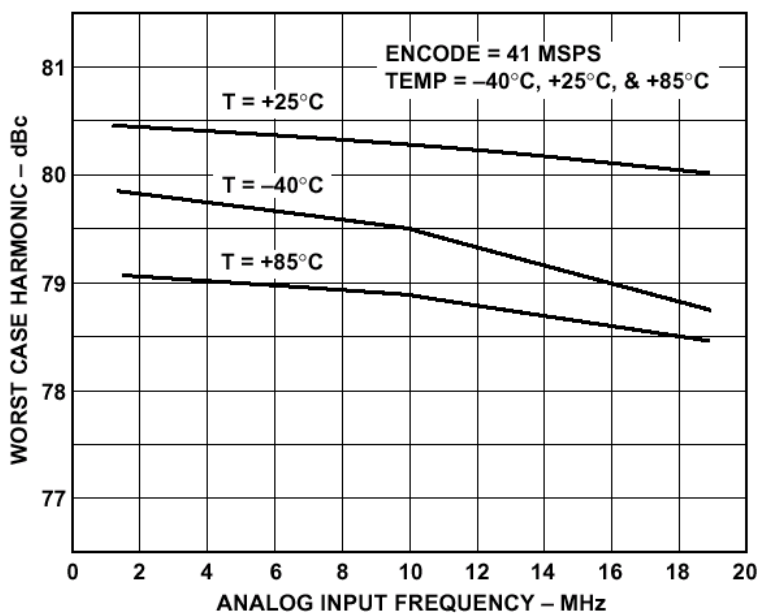

FIGURE 11. NOISE VS. AIN

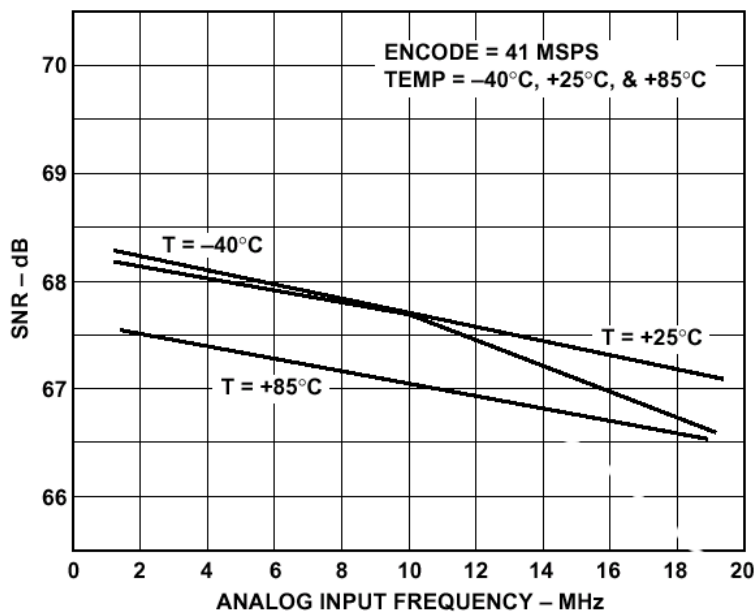

FIGURE 12. HARMONICS VS. AIN

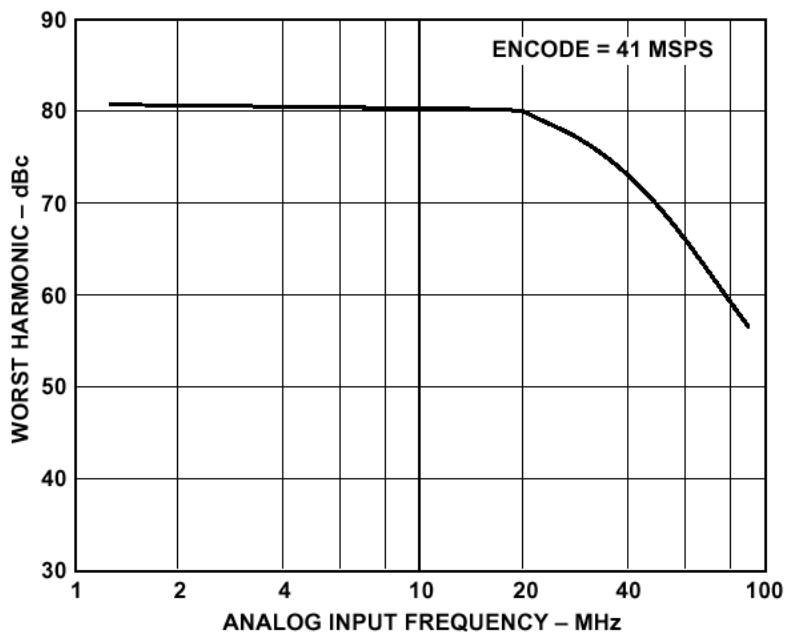

FIGURE 13. TWO TONES AT 15.3 MHz AND 19.5 MHz

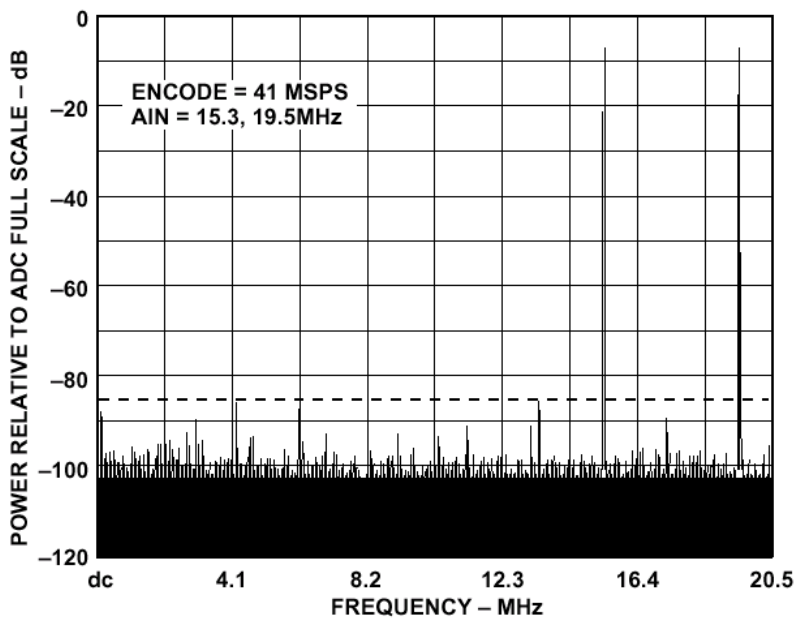

FIGURE 14. SINGLE TONE SFDR

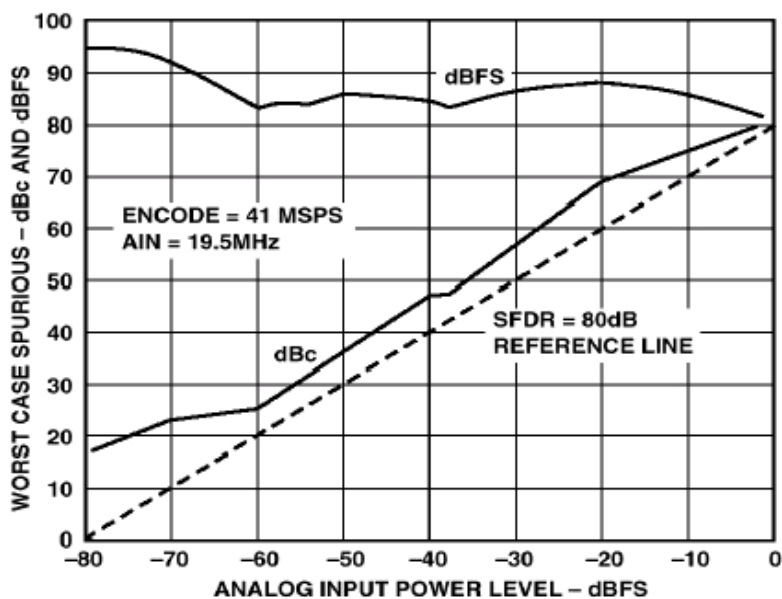

FIGURE 15. TWO TONES SFDR

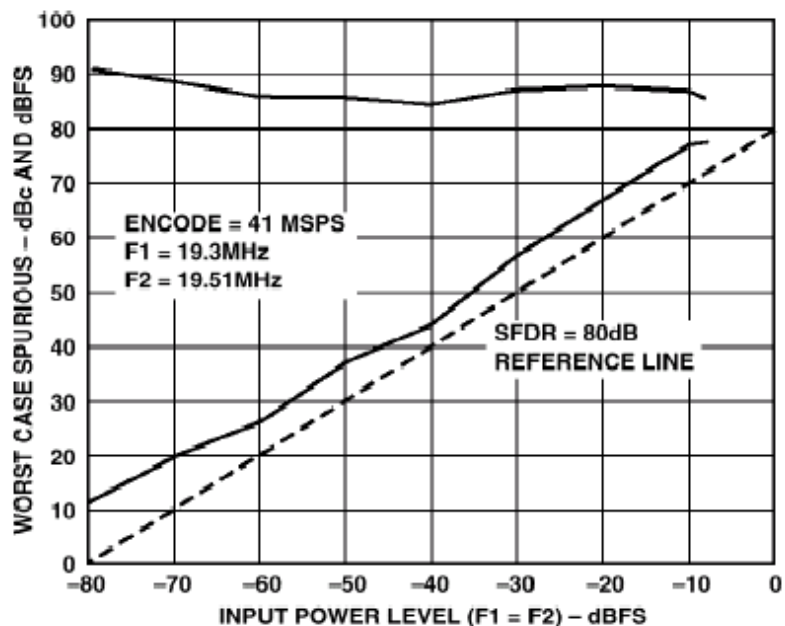

FIGURE 16. SNR WORST HARMONIC VS. ENCODE

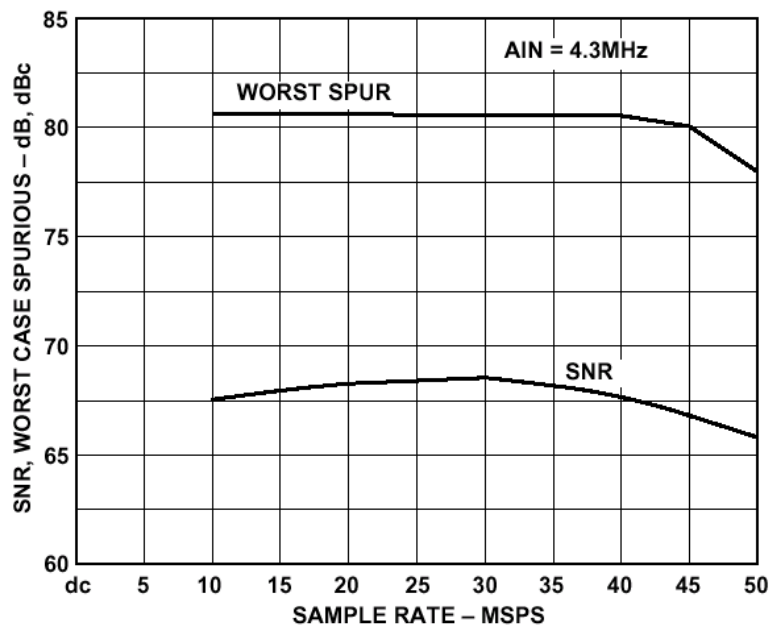

FIGURE 17. SNR WORST CASE SPURIOUS VS. DUTY CYCLE

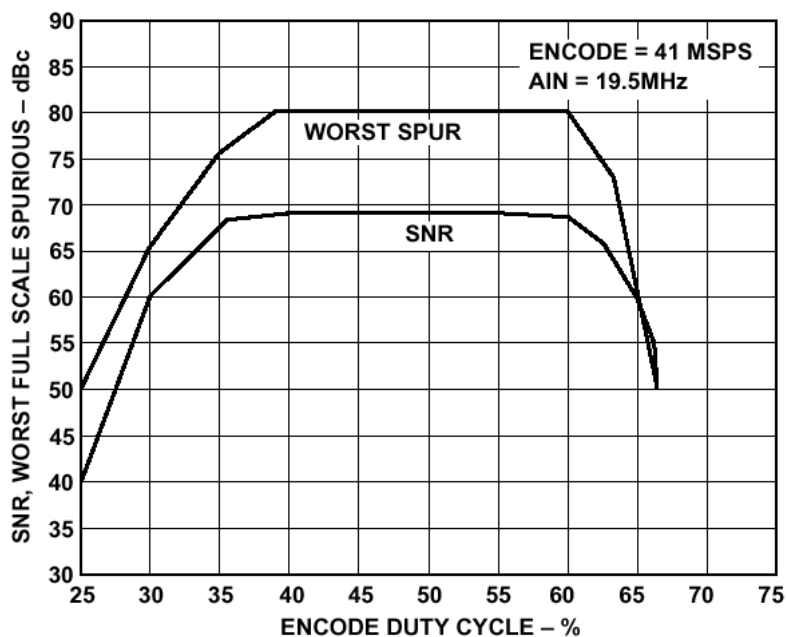
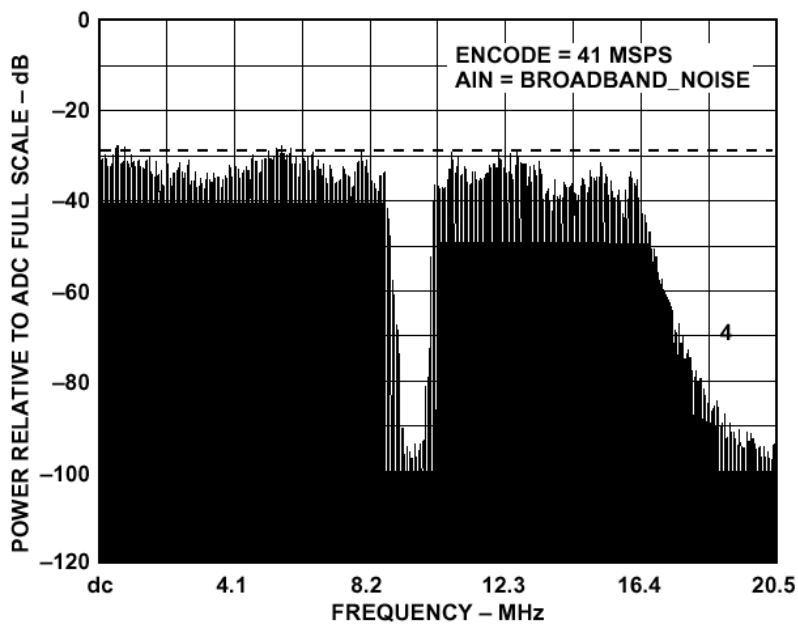

FIGURE 18. NPR OUTPUT SPECTRUM



## THEORY OF OPERATION

The 9042 analog-to-digital converter (ADC) employs a twostage subrange architecture. This design approach ensures 12-bit accuracy, without the need for laser trim, at low power. As shown in the functional block diagram, the 1 V p-p SingleEnded analog input, centered at 2.4 V, drives a single-in to differential-out amplifier, A1. The output of A1 drives the first track-and-hold, TH1. The high state of the ENCODE pulse places TH1 in hold mode. The held value of TH1 is applied to the input of the 6-bit coarse ADC. The digital output of the coarse ADC drives a 6-bit DAC; the DAC is 12 bits accurate. The output of the 6-bit DAC is subtracted from the delayed analog signal at the input to TH3 to generate a residue signal. TH2 is used as an analog pipeline to null out the digital delay of the coarse ADC. The residue signal is passed to TH3 on a subsequent clock cycle where the signal is amplified by the residue amplifier, A2, and converted to a digital word by the 7-bit residue ADC. One bit of overlap is used to accommodate any linearity errors in the coarse ADC.

The 6-bit coarse ADC word and 7-bit residue word are added together and corrected in the digital error correction logic to generate the output word. The result is a 12-bit parallel digital word which is CMOS-compatible, coded as twos complement.

## APPLYING THE 9042

## Encoding the 9042

The 9042 is designed to interface with TTL and CMOS logic families. The source used to drive the ENCODE pin(s) must be clean and free from jitter. Sources with excessive jitter will limit SNR (ref. Equation 1 under "Noise Floor and SNR").

Figure 19. Single-Ended TTL/CMOS Encode

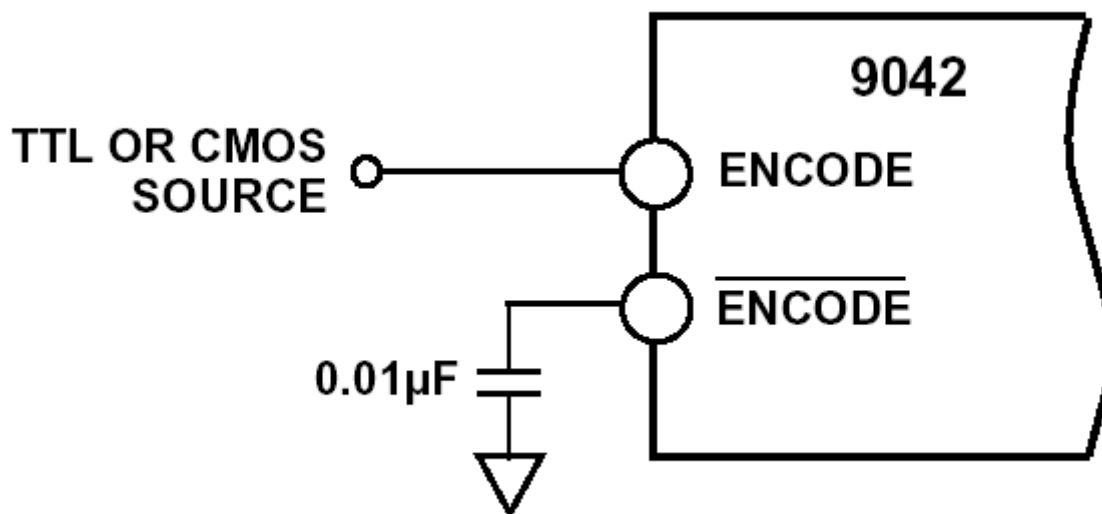

The 9042 encode inputs are connected to a differential input stage (See Figure 3). With no input connected to either the ENCODE or input, the voltage dividers bias the inputs to 1.6 volts. For TTL or CMOS usage, the encode source should be connected to ENCODE. ENCODE should be decoupled using a low inductance or microwave chip capacitor to ground. Devices such as AVX 05085C103MA15, a 0.01 mF capacitor, work well.

If a logic threshold other than the nominal 1.6 V is required, the following equations show how to use an external resistor,  $R_X$ , to raise or lower the trip point (See Figure 3;  $R_1 = 17k$ ,  $R_2 = 8k$ ).

$$V_1 = \frac{5R_2R_X}{R_1R_2 + R_1R_X + R_2R_X}$$

to lower logic threshold.

Figure 20. Lower Logic Threshold for Encode

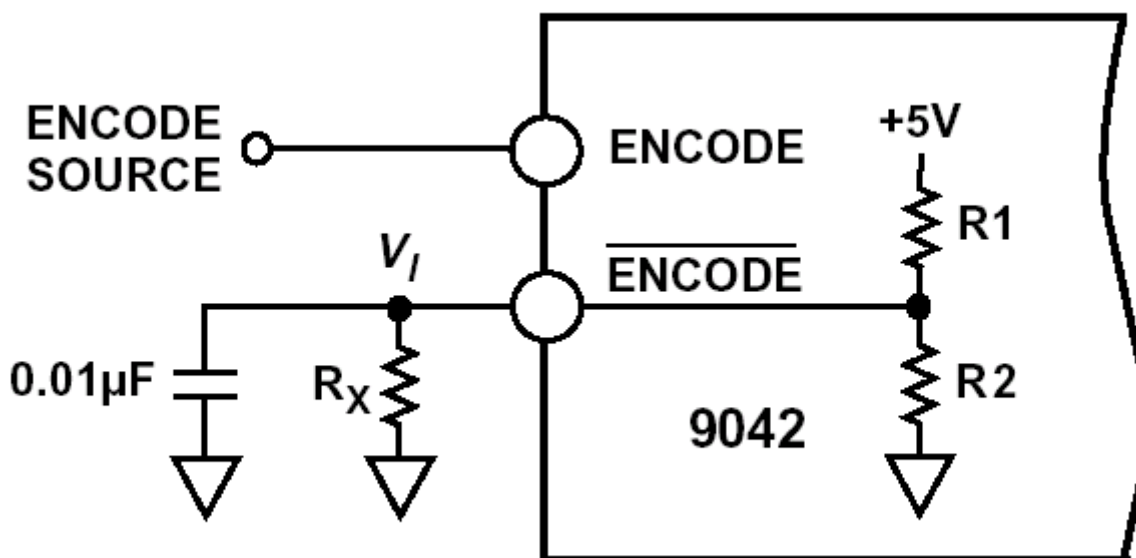

$$V_1 = \frac{5R_2}{R_2 + \frac{R_1R_X}{R_1 + R_X}}$$

to raise logic threshold.



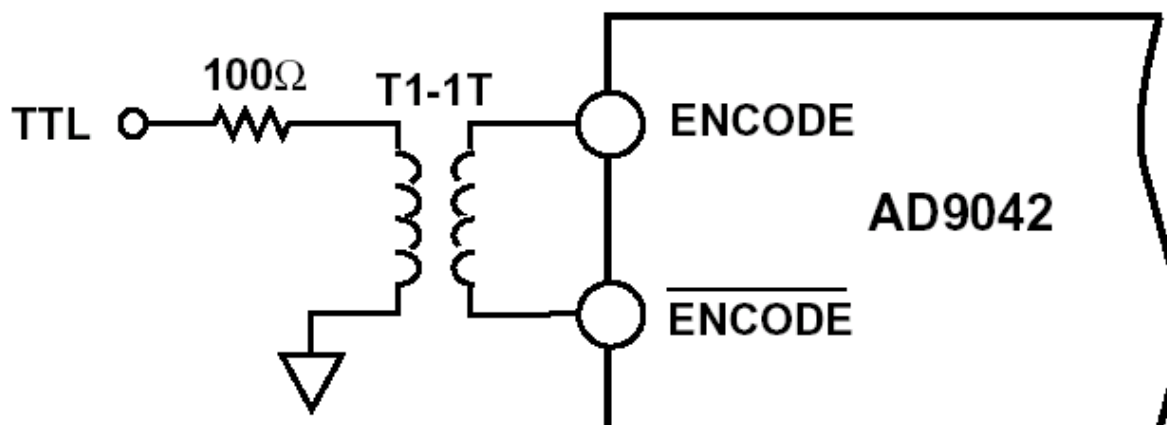

If no TTL source is available, a clean sine wave may be substituted. In the case of the sine source, the matching network is shown below. Since the matching transformer specified is a 1:1 impedance ratio, R, the load resistor should be selected to match the source impedance. The input impedance of the 9042 is negligible in most cases.

Figure 23. Sine Source – Differential Encode

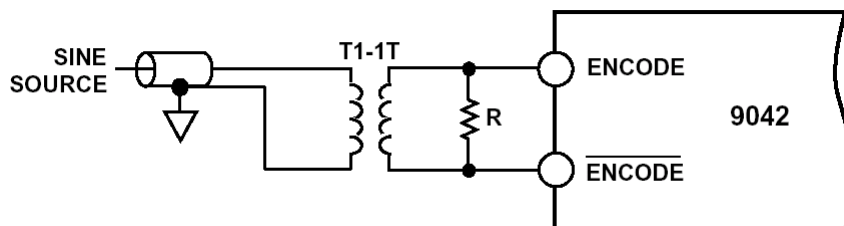

If a low jitter ECL clock is available, another option is to accouple a differential ECL signal to the encode input pins as shown below. The capacitors shown here should be chip capacitors but do not need to be of the low inductance variety.

Figure 24. Differential ECL for Encode

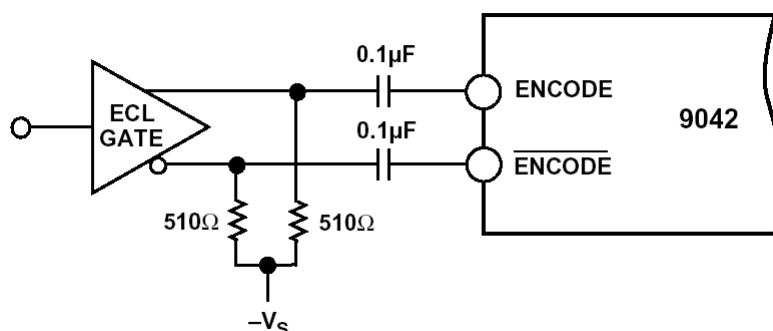

As a final alternative, the ECL gate may be replaced by an ECL comparator. The input to the comparator could then be a logic signal or a sine signal.

Figure 25. ECL Comparator for Encode

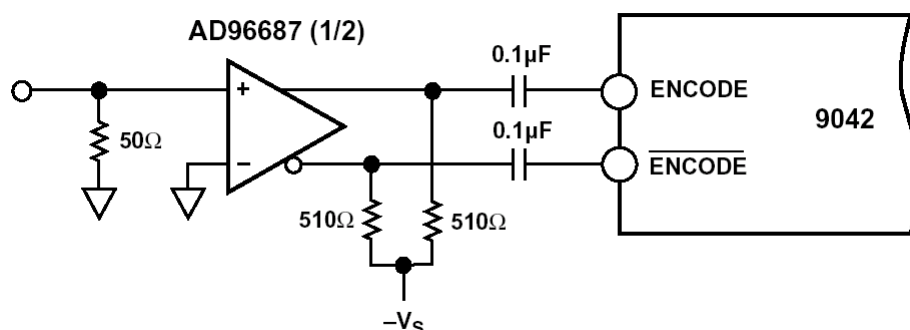

Care should be taken not to overdrive the encode input pin when ac coupled. Although the input circuitry is electrically protected from over or under voltage conditions, improper circuit operations may result from overdriving the encode input pins.

### Driving the Analog Input

Because the 9042 operates off of a single +5 V supply, the analog input range is offset from ground by 2.4 volts. The analog input, AIN, is an operational amplifier configured in an inverting mode (ref. Equivalent Circuits: Analog Input Stage). VOFFSET is the noninverting input which is normally tied through a 50 ohm resistor to VREF (ref. Equivalent Circuits: 2.4 V Reference). Since the operational amplifier forces its inputs to the same voltage, the inverting input is also at 2.4 volts. Therefore, the analog input has a Thevenin equivalent of 250 ohms in series with a 2.4 volt source. It is strongly recommended that the 9042's internal voltage reference be used for the amplifier offset; this reference is designed to track internal circuit shifts over temperature.

Figure 26. Analog Input Offset by +2.4 V Reference

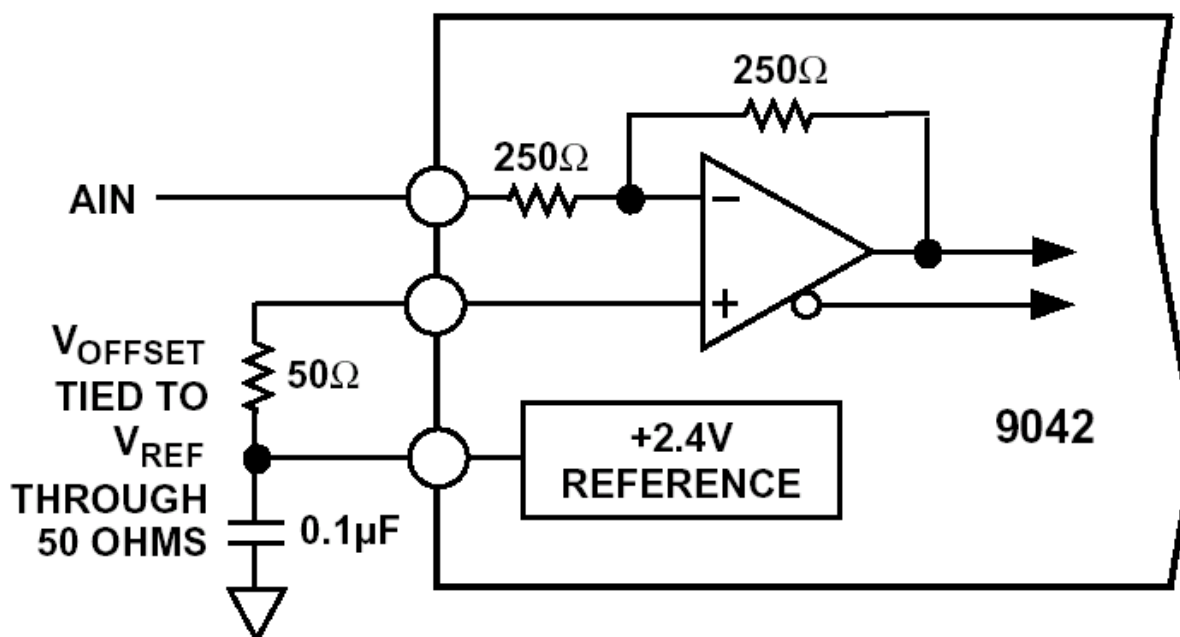

Although the 9042 may be used in many applications, it was specifically designed for communications systems which must digitize wide signal bandwidths. As such, the analog input was designed to be ac-coupled. Since most communications products do not down-convert to dc, this should not pose a problem. One example of a typical analog input circuit is shown below. In this application, the analog input is coupled with a high quality chip capacitor, the value of which can be chosen to provide a low frequency cutoff that is consistent with the signal being sampled; in most cases, a 0.1 mF chip capacitor will work well.

Figure 27. AC-Coupled Analog Input Signal

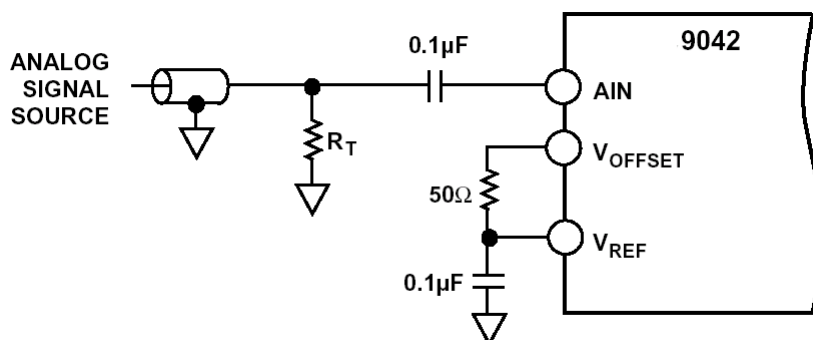

Another option for ac-coupling is a transformer. The impedance ratio and frequency characteristics of the transformer are determined by examining the characteristics of the input signal source (transformer primary connection), and the 9042 input characteristics (transformer secondary connection). “RT” should be chosen to satisfy termination requirements of the source, given the transformer turns ratio. A blocking capacitor is required to prevent 9042 dc bias currents from flowing through the transformer.

Figure 28. Transformer-Coupled Analog Input Signal

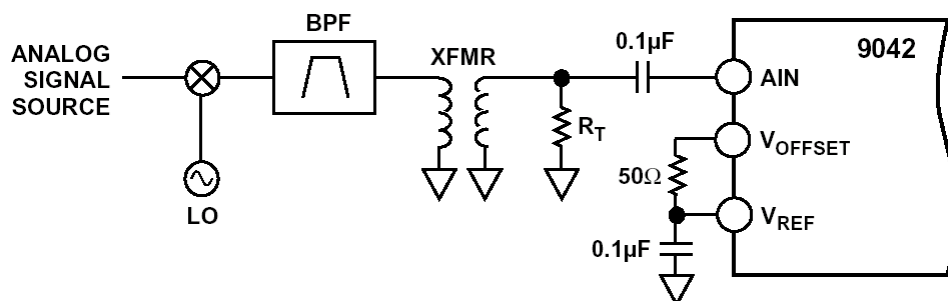

When calculating the proper termination resistor, note that the external load resistor is in parallel with the 9042 analog input resistance, 250 ohms. The external resistor value can be calculated from the following equation:

$$R_T = \frac{1}{\frac{1}{Z} - \frac{1}{250}}$$

where Z is desired impedance.

9042

A dc-coupled input configuration (shown below) is limited by the drive amplifier performance. The 9042's on-chip reference is buffered using the OP279 dual, rail-to-rail operational amplifier. The resulting voltage is combined with the analog source using an AD9631. Pending improvements in drive amplifiers, this dc-coupled approach is limited to ~75 dB–80 dB of dynamic performance depending on which drive amplifier is used. The AD9631 and OP279 run off ±5 V.

Figure 29. DC-Coupled Analog Input Circuit

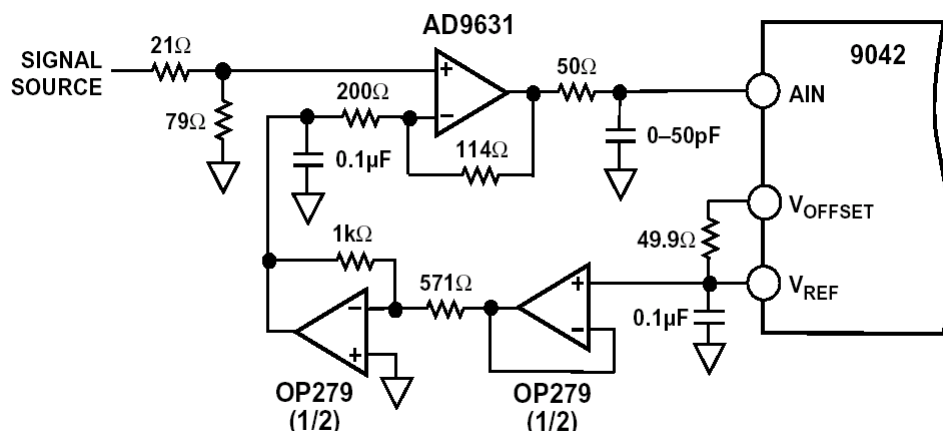

### Power Supplies

Care should be taken when selecting a power source. Linear supplies are strongly recommended as switching supplies tend to have radiated components that may be “received” by the 9042. Each of the power supply pins should be decoupled as closely to the package as possible using 0.1 mF chip capacitors. The 9042 has separate digital and analog +5 V pins. The analog supplies and the denoted  $A_{VCC}$  digital supply pins are denoted  $D_{VCC}$ . Although analog and digital supplies may be tied together, best performance is achieved when the supplies are separate. This is because the fast digital output swings can couple switching noise back into the analog supplies. Note that  $A_{VCC}$  must be held within 5% of 5 volts, however the  $D_{VCC}$  supply may be varied according to output digital logic family (i.e.,  $D_{VCC}$  should be connected to the supply for the digital circuitry).

### Output Loading

Care must be taken when designing the data receivers for the AD9042. It is recommended that the digital outputs drive a series resistor of 499 ohms followed by a CMOS gate like the 74AC574. To minimize capacitive loading, there should only be one gate on each output pin. The digital outputs of the 9042 have a unique constant slew rate output stage. The output slew rate is about 1 V/ns independent of output loading. A typical CMOS gate combined with PCB trace and through hole will have a load of approximately 10 pF. Therefore as each bit switches, 10 mA

$$\left( 10 \text{ pF} \times \frac{1 \text{ V}}{1 \text{ ns}} \right)$$

of dynamic current per bit will flow in or out of the device. A full-scale transition can cause up to 120 mA (12bits  $\times$  10 mA/bit) of current to flow through the digital output stage. The series resistor will minimize the output currents that can flow in the output stage. These switching currents are confined between ground and the  $D_{VCC}$  pin. Standard TTL gates should be avoided since they can appreciably add to the dynamic switching currents of the 9042.

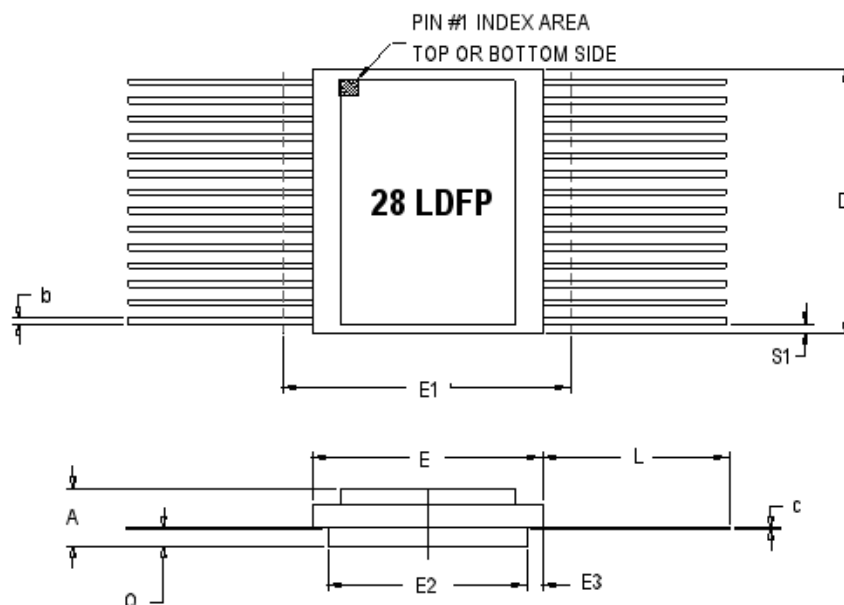

28-PIN RAD-PAK® FLAT PACKAGE

SYMBOL	DIMENSION		
	MIN	NOM	MAX
A	0.129	0.142	0.155
b	0.015	0.017	0.022
c	0.004	0.005	0.009
D	--	0.820	0.828
E	0.474	0.480	0.486
E1	--	--	0.506
E2	0.255	0.260	--
E3	0.000	0.110	--
e	0.050 BSC		
L	0.375	0.385	0.395
Q	0.021	0.025	0.029
S1	0.000	0.077	--
N	28		

Note: All dimensions in inches

## Important Notice:

These data sheets are created using the chip manufacturer's published specifications. Maxwell Technologies verifies functionality by testing key parameters either by 100% testing, sample testing or characterization.

The specifications presented within these data sheets represent the latest and most accurate information available to date. However, these specifications are subject to change without notice and Maxwell Technologies assumes no responsibility for the use of this information.

Maxwell Technologies' products are not authorized for use as critical components in life support devices or systems without express written approval from Maxwell Technologies.

Any claim against Maxwell Technologies must be made within 90 days from the date of shipment from Maxwell Technologies. Maxwell Technologies' liability shall be limited to replacement of defective parts.

## Product Ordering Options

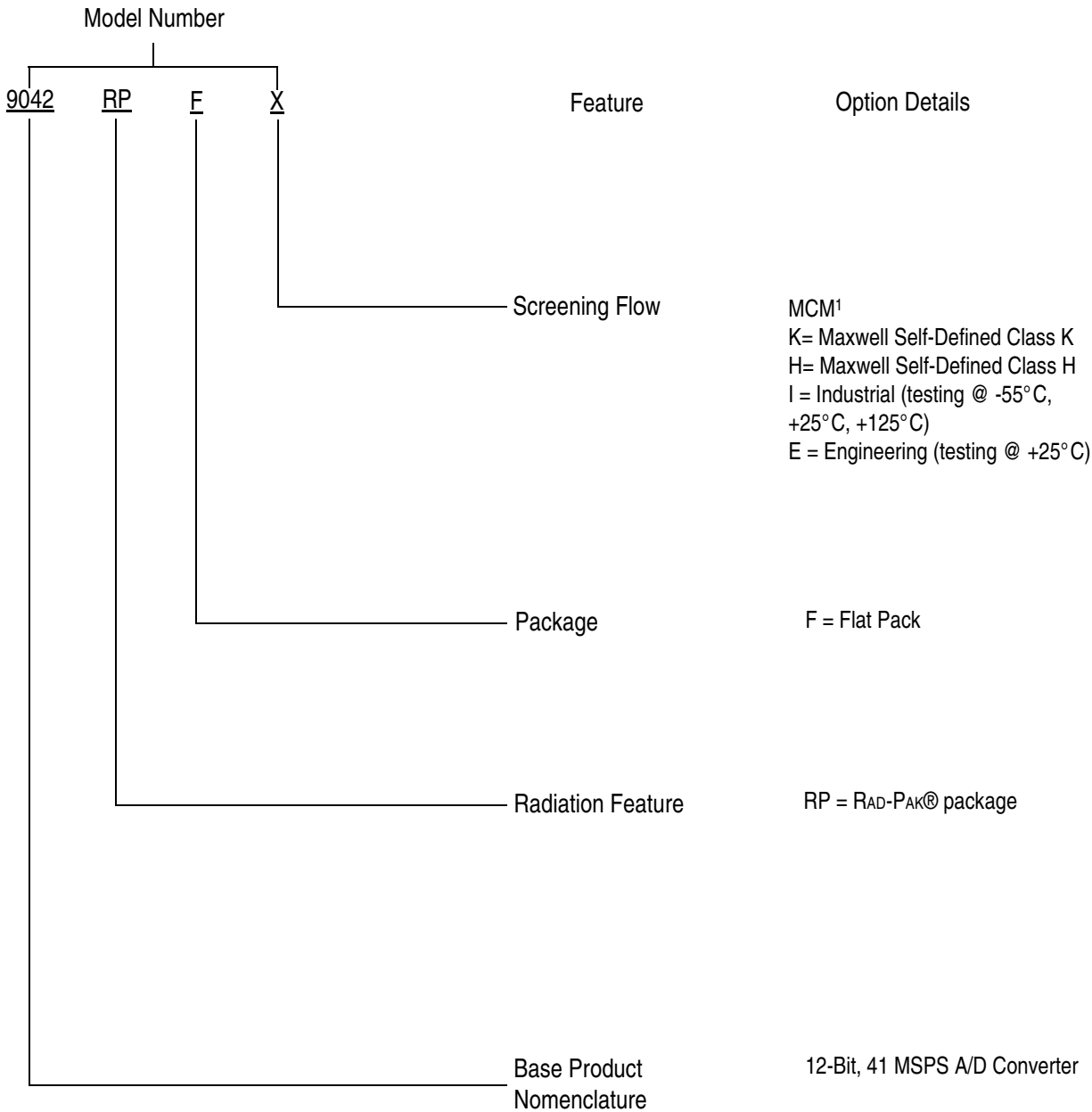

1) Products are manufactured and screened to Maxwell Technologies self-defined Class H and Class K flows.