

PicoEMI™ Programmable Spread Spectrum Clock

FEATURES

- Accepts Crystal or Reference Clock input
 - Crystal: 10MHz - 40MHz
 - Reference Clock: 1MHz - 200MHz
- Output Frequency up to 200MHz
- Center and Down Spread Spectrum Modulation
- Spread Spectrum On / Off Control
- Programmable Drive Strength, 4mA, 8mA or 16mA
- Max 100ps Cycle to Cycle jitter
- Single 2.5V ~ 3.3V, ± 10% power supply
- Operating temperature range from -40°C to 85°C
- Available in SOP-8L and TSSOP-8L GREEN/RoHS compliant packages

PIN CONFIGURATION

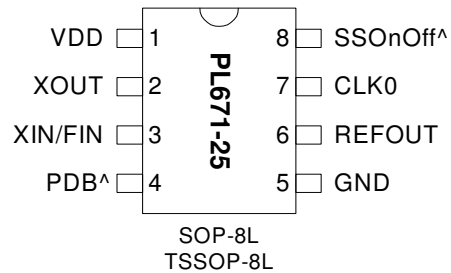

Note: ^ Denotes 60KΩ Pull-up resistor

DESCRIPTION

The PL671-25 is a high performance programmable spread spectrum clock. It allows for programming the modulation type (Center or Down Spread), 16 modulation magnitudes ($\pm 0.125\%$ to $\pm 2.0\%$ or -0.25% to -4.0%) and multiplication factor. The SSOnOff pin can be used to enable and disable the spread on the output for easy system performance comparison during EMI testing.

SSOnOff Pin	CLK0	Input (MHz)	Spread Spectrum Type	Spread Spectrum Modulation Amplitude	Output (MHz)
1	SS Off	10 – 40 (Xtal) 1 – 200 (REF)	Configurable as Center or Down	Configurable as Center: $\pm 0.125\%$ to $\pm 2.0\%$ Down: -0.25% to -4.0%	1 – 200 (Programmable Multiplier)
0	SS On				

BLOCK DIAGRAM

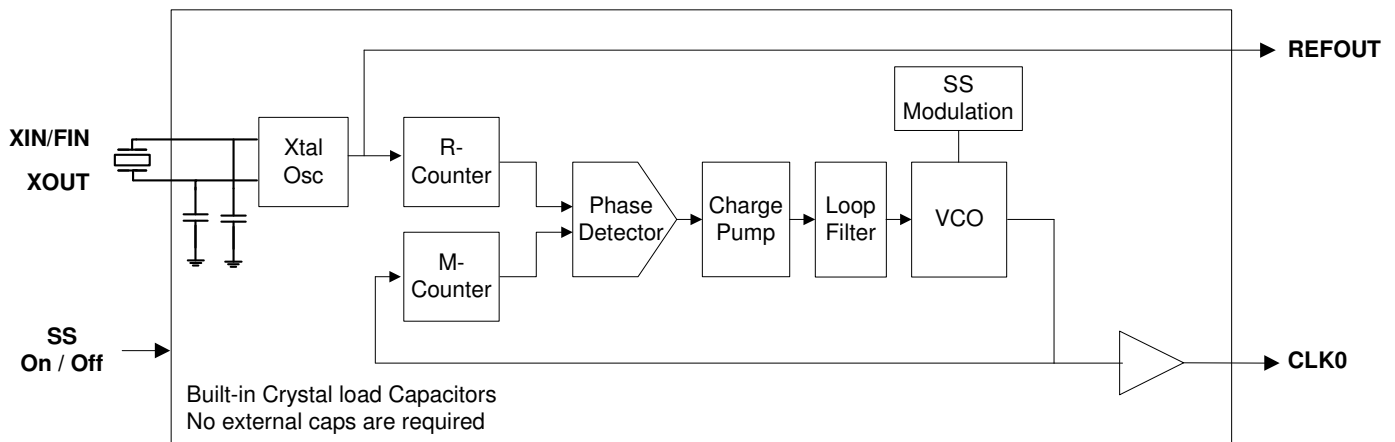

PicoEMI™ Programmable Spread Spectrum Clock

PACKAGE PIN ASSIGNMENT

Name	SOP-8L	Type	Description
VDD	1	P	VDD connection (2.25~3.63V)
XOUT	2	O	Crystal output pin. Do Not Connect when using FIN.
XIN/FIN	3	I	Crystal or Reference input pin
PDB	4	I	Power Down input. 60kΩ internal pull up resistor. Also configurable as Output Enable input.
GND	5	P	GND connection
REFOUT	6	O	Reference Output. Equal to the input frequency, no spread spectrum
CLK0	7	O	Spread Spectrum Clock Output
SSOnOff	8	I	Used to enable / disable the spread on CLK0, see page 1 for settings

LAYOUT RECOMMENDATIONS

The following guidelines are to assist you with a performance optimized PCB design:

Signal Integrity and Termination Considerations

- Keep traces as short as possible.
- Trace = Inductor. With a capacitive load this equals ringing!
- Long trace = Transmission Line. Without proper termination this will cause reflections (looks like ringing).
- Design long traces (>1 inch) as “striplines” or “microstrips” with defined impedance.
- Match trace at one side to avoid reflections bouncing back and forth.

Decoupling and Power Supply Considerations

- Place decoupling capacitors as close as possible to the VDD pin(s) to limit noise from the power supply
- Multiple VDD pins should be decoupled separately for best performance.
- Addition of a ferrite bead in series with VDD can help prevent noise from other board sources
- Value of decoupling capacitor is frequency dependant. Typical values to use are 0.1μF for designs using frequencies < 50MHz and 0.01μF for designs using frequencies > 50MHz.

Typical CMOS termination

Place Series Resistor as close as possible to CMOS output

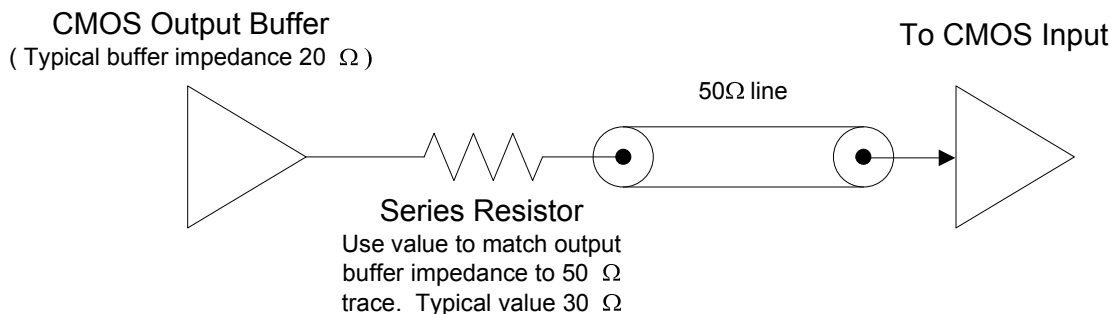

PicoEMI™ Programmable Spread Spectrum Clock

Crystal Tuning Circuit

Series and parallel capacitors used to fine tune the crystal load to the circuit load.

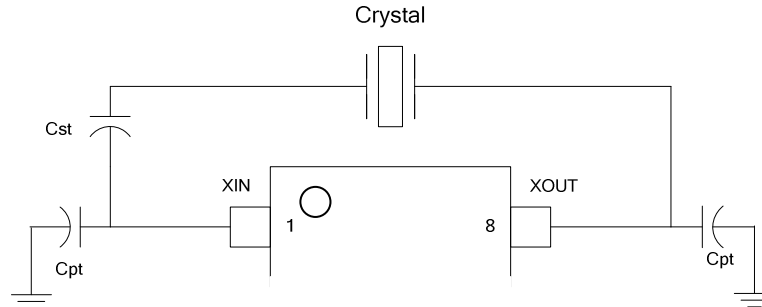

CST - Series Capacitor, used to lower circuit load to match crystal load. Raises frequency offset. This can be eliminated by using a crystal with a Load of equal or greater value than the oscillator.

CPT - Parallel Capacitors, Used to raise the circuit load to match the crystal load. Lowers frequency offset.

ELECTRICAL SPECIFICATIONS

ABSOLUTE MAXIMUM RATINGS

PARAMETERS	SYMBOL	MIN.	MAX.	UNITS
Supply Voltage Range	V_{DD}	-0.5	4.6	V
Input Voltage Range	V_I	-0.5	$V_{DD}+0.5$	V
Output Voltage Range	V_O	-0.5	$V_{DD}+0.5$	V
Soldering Temperature (Green package)			260	°C
Data Retention @ 85°C		10		Year
Storage Temperature	T_S	-65	150	°C
Ambient Operating Temperature*		-40	85	°C

Exposure of the device under conditions beyond the limits specified by Maximum Ratings for extended periods may cause permanent damage to the device and affect product reliability. These conditions represent a stress rating only, and functional operations of the device at these or any other conditions above the operational limits noted in this specification is not implied. *Operating temperature is guaranteed by design. Parts are tested to commercial grade only.

PicoEMI™ Programmable Spread Spectrum Clock
AC SPECIFICATIONS

PARAMETERS	CONDITIONS	MIN.	TYP.	MAX.	UNITS
Crystal Input Frequency(XIN)	Fundamental Crystal	10		40	MHz
Input (FIN) Frequency	@ V _{DD} =3.3V	1		200	MHz
	@ V _{DD} =2.5V			166	
Input (FIN) Signal Amplitude	Internally AC coupled (High Frequency)	0.9		V _{DD}	V _{pp}
Input (FIN) Signal Amplitude	Internally AC coupled (Low Frequency) 3.3V ≤50MHz, 2.5V ≤40MHz	0.1		V _{DD}	V _{pp}
Output Frequency	@ V _{DD} =3.3V			200	MHz
	@ V _{DD} =2.5V			166	MHz
Settling Time	At power-up (after V _{DD} increases over 2.25V)			2	ms
Output Enable Time	PDB Function; Ta=25° C, 15pF Load			2	ms
Output Rise Time	15pF Load, 10/90% V _{DD} , Standard Drive		2.0	3.0	ns
	15pF Load, 10/90% V _{DD} , High Drive		1.2	1.7	ns
Output Fall Time	15pF Load, 90/10% V _{DD} , Standard Drive		2.0	3.0	ns
	15pF Load, 90/10% V _{DD} , High Drive		1.2	1.7	ns
Duty Cycle	At V _{DD} /2	45	50	55	%
Cycle to Cycle Jitter*	T _{CYC-CYC} Over output frequency range @ 3.3V			100	ps

* Note: Jitter performance depends on the programming parameters.

DC SPECIFICATIONS

PARAMETERS	SYMBOL	CONDITIONS	MIN.	TYP.	MAX.	UNITS
Supply Current, Dynamic, with Loaded Outputs	I _{DD}	At 25MHz, 3.3V, load=15pF, (PDB=1)			15	mA
		PDB=0 [with reference input pin (FIN) pulled down]			10	μA
Operating Voltage	V _{DD}		2.25		3.63	V
Output Low Voltage	V _{OL}	I _{OL} = +4mA (Std. Drive)			0.4	V
Output High Voltage	V _{OH}	I _{OH} = -4mA (Std. Drive)	V _{DD} - 0.4			V
Output Current, Low Drive	I _{OSD}	V _{OL} = 0.4V, V _{OH} = 2.4V	4			mA
Output Current, Standard Drive	I _{OSD}	V _{OL} = 0.4V, V _{OH} = 2.4V	8			mA
Output Current, High Drive	I _{OHD}	V _{OL} = 0.4V, V _{OH} = 2.4V	16			mA

PicoEMI™ Programmable Spread Spectrum Clock

CRYSTAL SPECIFICATIONS

PARAMETERS		SYMBOL	MIN.	TYP.	MAX.	UNITS
Fundamental Crystal Resonator Frequency		F_{XIN}	10		40	MHz
Crystal Loading Rating		C_L (xtal)		15		pF
Maximum Sustainable Drive Level					100	μ W
Operating Drive Level				30		μ W
Metal Can Crystal	Shunt Capacitance	C0			5.5	pF
	ESR Max	ESR			50	Ω
Small SMD Crystal	Shunt Capacitance	C0			2.5	pF
	ESR Max	ESR			80	Ω

PACKAGE DRAWING (GREEN PACKAGE COMPLIANT)

8 PIN Package dimensions in mm

Symbol	SOP-8L		TSSOP-8L	
	Min.	Max.	Min.	Max.
A	1.35	1.75	-	1.20
A1	0.10	0.25	0.05	0.15
A2	1.25	1.50	-	1.20
b	0.33	0.53	0.19	0.30
C	0.19	0.27	0.09	0.20
D	4.80	5.00	2.90	3.10
E	3.80	4.00	4.30	4.50
H	5.80	6.20	6.20	6.60
L	0.40	0.89	0.45	0.75
e	1.27 BSC		0.65 BSC	

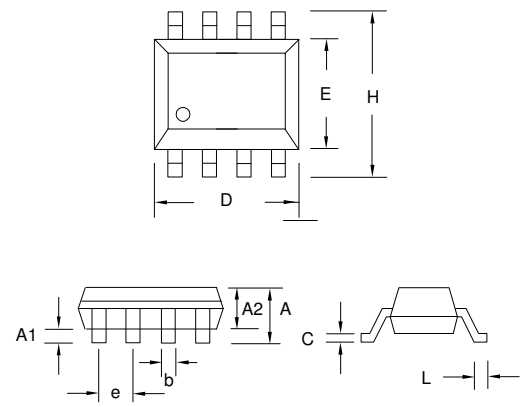

PicoEMI™ Programmable Spread Spectrum Clock

ORDERING INFORMATION (GREEN PACKAGE COMPLIANT)

For part ordering, please contact our Sales Department:

2880 Zanker Rd., San Jose, CA 95134, USA

Tel: (408) 571-1668 Fax: (408) 571-1688

PART NUMBER

The order number for this device is a combination of the following:
Part Number, Package Type and Operating Temperature Range

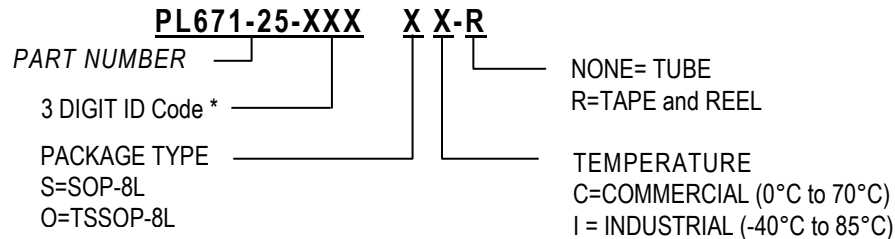

* PhaseLink will assign a unique 3-digit ID code for each approved programmed part number.

Part/Order Number	Marking†	Package Option
PL671-25-XXXSC	P671-25 XXX	8-Pin SOP (Tube)
PL671-25-XXXSC-R	P671-25 XXX	8-Pin SOP (Tape and Reel)
PL671-25-XXXOC	P671-25 XXX	8-Pin TSSOP (Tube)
PL671-25-XXXOC-R	P671-25 XXX	8-Pin TSSOP (Tape and Reel)

† Note: 'XXX' designates marking identifier that, at times, could be independent of the part number.
Please consult your PhaseLink sales representative for marking information.

PhaseLink Corporation, reserves the right to make changes in its products or specifications, or both at any time without notice. The information furnished by Phaselink is believed to be accurate and reliable. However, PhaseLink makes no guarantee or warranty concerning the accuracy of said information and shall not be responsible for any loss or damage of whatever nature resulting from the use of, or reliance upon this product.

LIFE SUPPORT POLICY: PhaseLink's products are not authorized for use as critical components in life support devices or systems without the express written approval of the President of PhaseLink Corporation.

Solder reflow profile available at www.phaselink.com/QA/solderingGreen.pdf