

Ultra Low Power PicoPLL, Programmable 3-PLL Clock IC

FEATURES

- Designed for PCB Space Savings with 3 Low-Power Programmable PLLs
- Ultra Low-Power Consumption
- Ultra-Low Power Down Mode, <math><5\mu\text{A}</math> Typical
- CLK1 Capable of Generating 32.768kHz
- Individual Output Buffer V_{DD} Pins for Flexible Output Voltages, 1.8V to 3.3V, $\pm 10\%$
- Individual PLL Power Down Control
- Output Frequency (based on V_{DD_CORE} voltage):
 - $\leq 65\text{MHz}$ @ 1.8V operation
 - $\leq 90\text{MHz}$ @ 2.5V operation
 - $\leq 125\text{MHz}$ @ 3.3V operation
- Input Frequency:
 - Fundamental Crystal: 10MHz to 40MHz
 - Reference Input: 10MHz to 200MHz
- Active Low or Hi-Z Disabled Output State
- 1.8V to 3.3V, $\pm 10\%$ Core Power Supply
- 1.8V to 3.3V, $\pm 10\%$ Buffer Power Supply
- Operating Temperature Ranges:
 - Commercial: 0°C to 70°C
 - Industrial: -40°C to 85°C
- Available in GREEN/RoHS Compliant 3x3 QFN Package

PIN CONFIGURATION

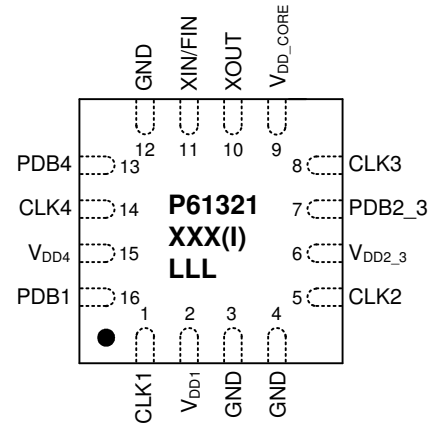

QFN-16L Package

DESCRIPTION

The PL613-21 is an advanced three PLL design based on PhaseLink’s PicoPLL, the world’s smallest programmable clock technology. This advanced technology allows the PL613-21 to fit in to a small 3x3mm QFN package for high performance, low-power, small form-factor applications. By using the individual output buffer V_{DD} pins, the PL613-21 can support multiple output voltage requirements. In addition, CLK1 has the ability to generate kHz outputs and is ideal for generating 32.768kHz outputs.

The unique power down features of the PL613-21 allows the user to shut down individual PLLs when the corresponding clock output is disabled using the PDB pins. The output drive strength can be individually programmed on each output to Low (4mA), Standard (8mA) or High (16mA) drive. In addition, the disabled state of the clock outputs can be programmed as Hi-Z or Active Low.

Besides its small form factor and multiple outputs that can reduce overall system costs, the PL613-21 offers superior phase noise, jitter and power consumption performance.

Ultra Low Power PicoPLL, Programmable 3-PLL Clock IC

BLOCK DIAGRAM

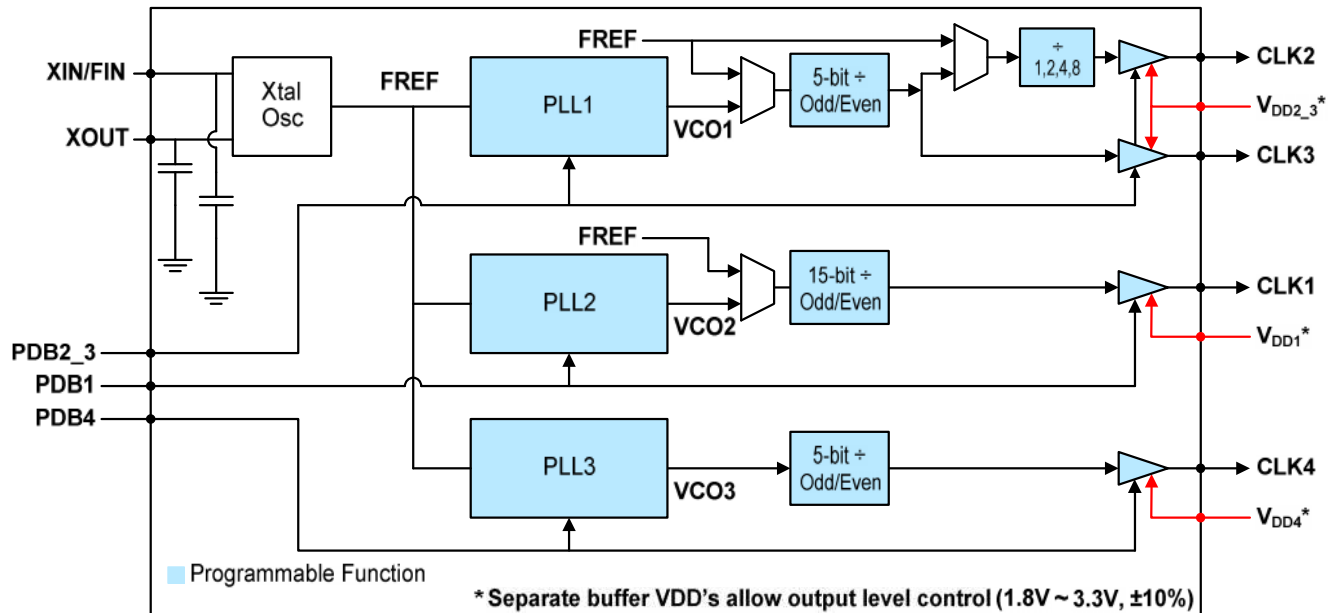

PACKAGE PIN ASSIGNMENT

Name	Package Pin # QFN-16L	Type	Description
CLK1	1	O	Programmable clock output
V _{DD1}	2	P	V _{DD} connection for output buffer CLK1
GND	3, 4, 12	P	GND connection
CLK2	5	O	Programmable clock output
V _{DD2_3}	6	P	V _{DD} connection for output buffers CLK2 and CLK3
PDB2_3*	7	I	Power down input for PLL1, CLK2 and CLK3
CLK3	8	O	Programmable clock output
V _{DD_CORE}	9	P	V _{DD} connection for core
XOUT	10	O	Crystal output pin. Do Not Connect when using FIN
XIN/FIN	11	I	Crystal or Reference Clock input
PDB4*	13	I	Power down input for PLL3 and CLK4
CLK4	14	O	Programmable clock output
V _{DD4}	15	P	V _{DD} connection for output buffer CLK4
PDB1*	16	I	Power down input for PLL2 and CLK1

*Note: The PDB pins have no internal pull up or pull down resistors. These pins must be driven to a logic 1 ($\geq 1.62V$) or logic 0 ($\leq 0.4V$) at startup to stabilize the corresponding output(s).

Ultra Low Power PicoPLL, Programmable 3-PLL Clock IC

POWER DOWN OPERATION

The PL613-21 has three pins which allow the user to power down each PLL and its corresponding clock output(s) when not in use. When all three PDB pins are pulled low the device enters full power down mode and draws <math><5\mu A</math> typical. The disabled state of the clock outputs can be programmed as Hi-Z or Active Low.

PDB INPUT			INTERNAL BLOCK				OUTPUT			
PDB1	PDB2_3	PDB4	Oscillator	PLL1	PLL2	PLL3	CLK1	CLK2	CLK3	CLK4
1	1	1	running	running	running	running	ON	ON	ON	ON
1	1	0	running	running	running	power down	ON	ON	ON	OFF
1	0	1	running	power down	running	running	ON	OFF	OFF	ON
1	0	0	running	power down	running	power down	ON	OFF	OFF	OFF
0	1	1	running	running	power down	running	OFF	ON	ON	ON
0	1	0	running	running	power down	power down	OFF	ON	ON	OFF
0	0	1	running	power down	power down	running	OFF	OFF	OFF	ON
0	0	0	power down	power down	power down	power down	OFF	OFF	OFF	OFF

Note: Typical output enable time is <math><100\mu s</math> for single PDB operation when any other PDB pin is high. When part is in full power down mode (all three PDB pins in low state) the typical output enable time is <math><2mS</math>.

The PDB pins have no internal pull up or pull down resistors. These pins must be driven to a logic 1 ($\geq 1.62V$) or logic 0 ($\leq 0.4V$) at startup to stabilize the corresponding output(s).

If the output from CLK1 and/or CLK4 will not be used in a design then the corresponding PDB pin must be tied to GND.

Power up in Power Down

The PDB pins should be grounded or connected to the corresponding V_{DDs} during power-up. If the PDB pins are grounded during power up the power down current is not guaranteed immediately after power-up. The Power Down current will be in spec if at least one PDB pin is pulled high for at least 2mS after power-up and then pulled low.

CORE AND BUFFER POWER SUPPLIES

The PL613-21 is capable of supporting multiple voltage levels for the core and buffers. The core voltage is supplied at pin 9 (V_{DD_CORE}) and can operate at a nominal V_{DD_CORE} between 1.8V and 3.3V. The tolerance of V_{DD_CORE} is $\pm 10\%$.

There are three output buffer voltage inputs which allow multiple output voltages to be supported by one device.

Pin	CLK Buffer	Operating Voltage
V_{DD1} (Pin 2)	CLK1	1.8V to 3.3V, $\pm 10\%$
V_{DD2_3} (Pin 6)	CLK2 CLK3	1.8V to 3.3V, $\pm 10\%$
V_{DD4} (Pin 15) (See V_{DD_CORE} vs. V_{DD4} Design Considerations and Requirements below)	CLK4	1.8V to 3.3V, $\pm 10\%$

This flexible power supply structure allows the core device to run at the lowest available V_{DD} and still support higher V_{DD} swing outputs.

Ultra Low Power PicoPLL, Programmable 3-PLL Clock IC

V_{DD_CORE} vs. V_{DD4} DESIGN CONSIDERATIONS AND REQUIREMENTS

Power supply voltage (DC) at V_{DD4} must be greater than or equal to power supply voltage (DC) at V_{DD_CORE} (V_{DD4} ≥ V_{DD_CORE}). If V_{DD4} = V_{DD_CORE}, V_{DD4} and V_{DD_CORE} must be supplied from the same power supply.

The ramp time of V_{DD_CORE} and V_{DD4} must be between 100µS and 250mS from 0V to 90% of VDD target. These VDD ramps need to be monotonic rising.

LAYOUT RECOMMENDATIONS

The following guidelines are to assist you with a performance optimized PCB design:

Signal Integrity and Termination Considerations

- Keep traces short!
- Trace = Inductor. With a capacitive load this equals ringing!
- Long trace = Transmission Line. Without proper termination this will cause reflections (looks like ringing).
- Design long traces (<1 inch) as “striplines” or “microstrips” with defined impedance.
- Match trace at one side to avoid reflections bouncing back and forth.

Decoupling and Power Supply Considerations

- Place decoupling capacitors as close as possible to the V_{DD} pin(s) to limit noise from the power supply
- Multiple V_{DD} pins should be decoupled separately for best performance.
- Addition of a ferrite bead in series with V_{DD} can help prevent noise from other board sources
- Value of decoupling capacitor is frequency dependant. Typical values to use are 0.1µF for designs using frequencies < 50MHz and 0.01µF for designs using frequencies > 50MHz.

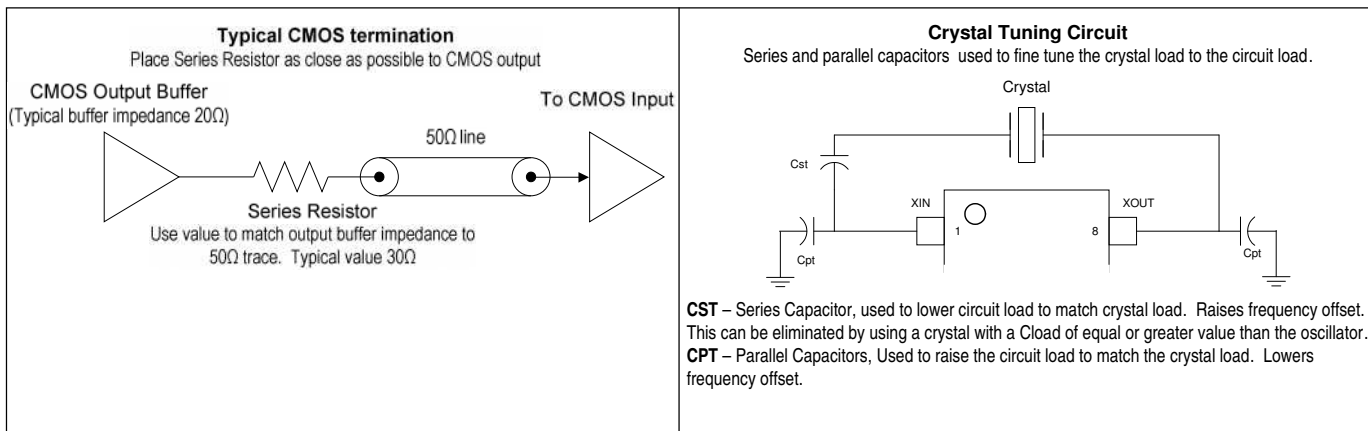

Ultra Low Power PicoPLL, Programmable 3-PLL Clock IC

ELECTRICAL SPECIFICATIONS

ABSOLUTE MAXIMUM RATINGS

PARAMETERS	SYMBOL	MIN	MAX	UNITS
Supply Voltage Range	V_{DD}	-0.5	4.6	V
Input Voltage Range	V_I	-0.5	$V_{DD}+0.5$	V
Output Voltage Range	V_O	-0.5	$V_{DD}+0.5$	V
Soldering Temperature			260	°C
Data Retention @ 85°C		10		Year
Storage Temperature	T_S	-65	150	°C
Ambient Operating Temperature		-40	85	°C

Exposure of the device under conditions beyond the limits specified by Maximum Ratings for extended periods may cause permanent damage to the device and affect product reliability. These conditions represent a stress rating only, and functional operations of the device at these or any other conditions above the operational limits noted in this specification is not implied.

DC SPECIFICATIONS

PARAMETERS	SYMBOL	CONDITIONS	MIN	TYP	MAX	UNITS
Supply Current, All $V_{DD} = 3.3V$	I_{DD}	Input 16.368MHz fundamental mode crystal, CLK2,3,4 outputs at 40MHz, CLK1 output at 32.768kHz, No Load.		9.2		mA
Supply Current, All $V_{DD} = 2.5V$	I_{DD}			6.5		mA
Supply Current, All $V_{DD} = 1.8V$	I_{DD}			4.7		mA
Supply Current	I_{DD}	When all PDB=0, 25°C		5		µA
Typical V_{DD_CORE} Operating Voltages	V_{DD_CORE}	3.3V Operation	2.97	3.3	3.63	V
		2.5V Operation	2.25	2.5	2.75	
		1.8V Operation	1.62	1.8	1.98	
Power Supply Ramp	t_{PU}	Time for V_{DD_CORE} and V_{DD4} to reach 90% target V_{DD} . Power ramp must be monotonic rising.	0.1		250	ms
V_{DDX} Buffer Voltage	V_{DDX}		1.62		3.63	V
Output Low Voltage	V_{OL}	$I_{OL} = +4mA, V_{DDX} = 3.3V$			0.4	V
Output High Voltage	V_{OH}	$I_{OH} = -4mA, V_{DDX} = 3.3V$	2.4			V
Output Current, Low Drive	I_{OLD}	$V_{OL} = 0.4V, V_{OH} = 2.4V, V_{DD}=3.3V$	±4			mA
Output Current, Std Drive	I_{OSD}	$V_{OL} = 0.4V, V_{OH} = 2.4V, V_{DD}=3.3V$	±8			mA
Output Current, High Drive	I_{OHD}	$V_{OL} = 0.4V, V_{OH} = 2.4V, V_{DD}=3.3V$	±16			mA

Ultra Low Power PicoPLL, Programmable 3-PLL Clock IC

AC SPECIFICATIONS

PARAMETERS	CONDITIONS	MIN	TYP	MAX	UNITS
Input (XIN) Frequency	Fundamental Crystal	10		40	MHz
Input (FIN) Frequency	$V_{DD_CORE} \geq 2.5V$	10		200	MHz
	$V_{DD_CORE} = 1.8V$	10		100	
Input (FIN) Signal Amplitude	Internally AC coupled (High Frequency)	0.8		3.3	V _{PP}
Output Frequency CLK2, CLK3, CLK4	$V_{DDx} = 3.3V$	1		125	MHz
	$V_{DDx} = 2.5V$			90	
	$V_{DDx} = 1.8V$			65	
Output Frequency CLK1	$V_{DD1} = 3.3V$	0.0002		13	MHz
	$V_{DD1} = 2.5V$			13	
	$V_{DD1} = 1.8V$			1	
Settling Time	At power-up (after V_{DD_CORE} & $V_{DD4} > 90\% V_{DD}$)		2	5	ms
Output Enable Time	PDBx Function, In operating mode (at least one other PDB=1); Ta=25°C, 15pF Load. Add one clock period to this measurement for a usable clock output.			100	μs
	PDBx Function, from full power down (all PDB=0); Ta=25°C, 15pF Load, F _{IN} or crystal present and > 10MHz		2	5	ms
VDD Sensitivity	Frequency vs. $V_{DD} \pm 10\%$	-2		2	ppm
Output Rise Time	15pF Load, 10/90% V _{DD} , High Drive, 3.3V		1.2	1.7	ns
	15pF Load, 10/90% V _{DD} , Std Drive, 3.3V		2.0	3.0	
	15pF Load, 10/90% V _{DD} , Low Drive, 3.3V		6.0	8.0	
Output Fall Time	15pF Load, 90/10% V _{DD} , High Drive, 3.3V		1.2	1.7	ns
	15pF Load, 90/10% V _{DD} , Std Drive, 3.3V		2.0	3.0	
	15pF Load, 90/10% V _{DD} , Low Drive, 3.3V		6.0	8.0	
Duty Cycle for CLK2, CLK3 & CLK4	PLL Enabled, @ $V_{DD} / 2$, Entire Frequency Range, High Drive	45	50	55	%
Duty Cycle for CLK1	PLL Enabled, $V_{DD} / 2$, CLK1 $\leq 1MHz$	45	50	55	%
	PLL Enabled, $V_{DD} / 2$, $1MHz \leq CLK1 \leq 13MHz$ (See Output Frequency CLK1)	40	50	60	
Period Jitter, Pk-to-Pk* (10,000 samples)	Configuration Dependent, Outputs $\geq 10MHz$		300		ps

*: Jitter performance depends on programming parameters

Ultra Low Power PicoPLL, Programmable 3-PLL Clock IC

CRYSTAL SPECIFICATIONS

PARAMETERS		SYMBOL	MIN	TYP	MAX	UNITS
Fundamental Crystal Resonator Frequency		F_{XIN}	10		40	MHz
Crystal Loading Rating		$C_{L(xtal)}$		15		pF
Operating Drive Level				0.1	1.0	mW
Metal Can Crystal	Shunt Capacitance	C_0			5.5	pF
	ESR Max	ESR			40	
Small SMD Crystal	Shunt Capacitance	C_0			2.5	pF
	ESR Max	ESR			60	

Ultra Low Power PicoPLL, Programmable 3-PLL Clock IC

PACKAGE DRAWING (GREEN PACKAGE COMPLIANT)

QFN-16L

Symbol	Dimension (mm)		
	Min	Nom	Max
A	0.70	0.75	0.80
A1	0.00	-	0.05
A3	0.203 Ref		
b	0.20	0.25	0.30
D	2.95	3.00	3.05
E	2.95	3.00	3.05
D1	1.65	1.70	1.75
E1	1.65	1.70	1.75
L	0.250	0.300	0.350
e	0.50BSC		

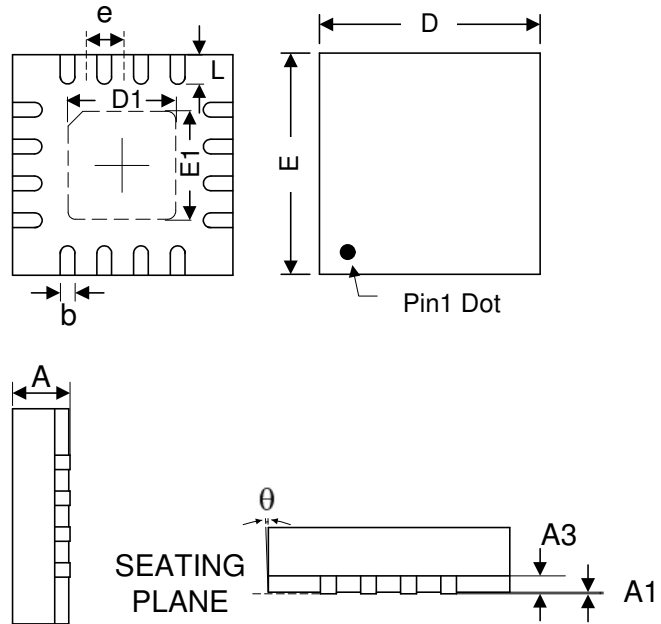

Recommended Land Pattern (mm)

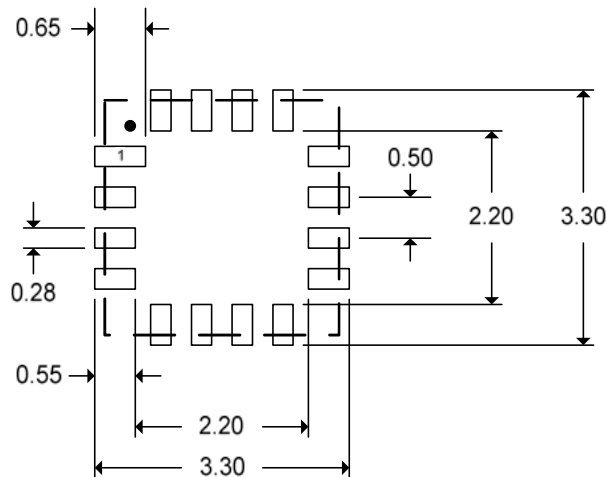

Note: The pad underneath the QFN package is connected to the substrate. There should be no bare traces or bare metal under the package.

Ultra Low Power PicoPLL, Programmable 3-PLL Clock IC

ORDERING INFORMATION (GREEN PACKAGE COMPLIANT)

For part ordering, please contact our Sales Department:

2880 Zanker Rd., Suite 103, San Jose, CA 95134, USA

Tel: (408) 571-1668 Fax: (408) 571-1688

PART NUMBER

The order number for this device is a combination of the following:

Part number, Package type and Operating temperature range

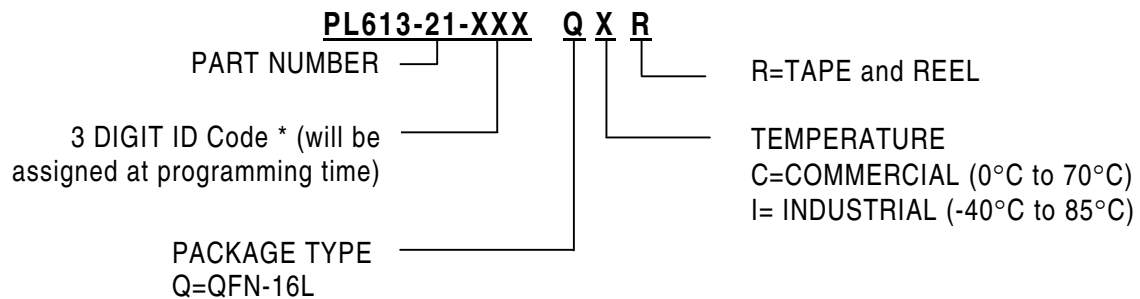

* PhaseLink will assign a unique 3-digit ID code for each approved programmed part number.

Part Number/Order Number	Marking†	Package Option
PL613-21-XXXQC-R	P61321 XXX(I) LLL	16-Pin QFN (Tape and Reel)

† **Marking Notes :**

- 1) The "I" after the three digit programming code will be marked for Industrial Temperature grade products only. Commercial grade products will not have a character in this position.
- 2) LLL represents the production lot number

PhaseLink Corporation, reserves the right to make changes in its products or specifications, or both at any time without notice. The information furnished by Phaselink is believed to be accurate and reliable. However, PhaseLink makes no guarantee or warranty concerning the accuracy of said information and shall not be responsible for any loss or damage of whatever nature resulting from the use of, or reliance upon this product.

LIFE SUPPORT POLICY: PhaseLink's products are not authorized for use as critical components in life support devices or systems without the express written approval of the President of PhaseLink Corporation.

Solder reflow profile available at www.phaselink.com/QA/solderingGreen.pdf