

**Programmable Quick Turn Clock**

**FEATURES**

- Advanced programmable PLL design
- Very low Jitter and Phase Noise (< 40ps Pk-Pk typ.)
- Supports complementary LVCMOS outputs to drive LVPECL and LVDS inputs.
- Output Frequencies:
  - $\leq 400\text{MHz}$  at 3.3V
  - $\leq 350\text{MHz}$  at 2.5V
- Input Frequencies:
  - Fundamental Crystal: 10MHz - 30MHz
  - 3<sup>RD</sup> overtone Crystal: Up to 75MHz
  - Reference Input: Up to 200MHz
- Accepts <1.0V reference signal input voltage
- One programmable I/O pin can be configured as Output Enable (OE) input, Frequency Selection (FSEL) input or Reference Clock (CLK2) output.
- Single 2.5V or 3.3V  $\pm 10\%$  power supply
- Operating temperature range from -40°C to 85°C
- Available in 8-pin MSOP/SOP Green/RoHS compliant packages.

**PIN CONFIGURATION**

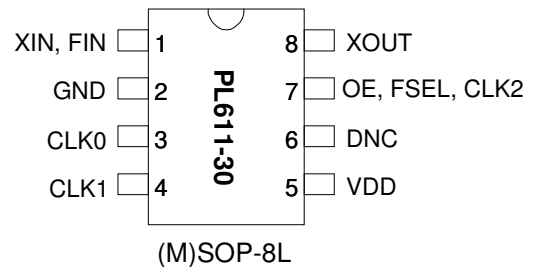

**DESCRIPTION**

The PL611-30 is a low-cost general purpose frequency synthesizer and a member of PhaseLink’s Factory Programmable ‘Quick Turn Clock (QTC)’ family. PhaseLink’s PL611-30 product family can generate any output frequency up to 400MHz from fundamental crystal input between 10MHz - 30MHz, a 3rd overtone crystal of up to 75MHz (3.3V Only) or a Reference Clock from 1MHz to 200MHz. The PL611-30 produces complementary LVCMOS outputs to support LVPECL, LVDS, and LVCMOS inputs.

**BLOCK DIAGRAM**

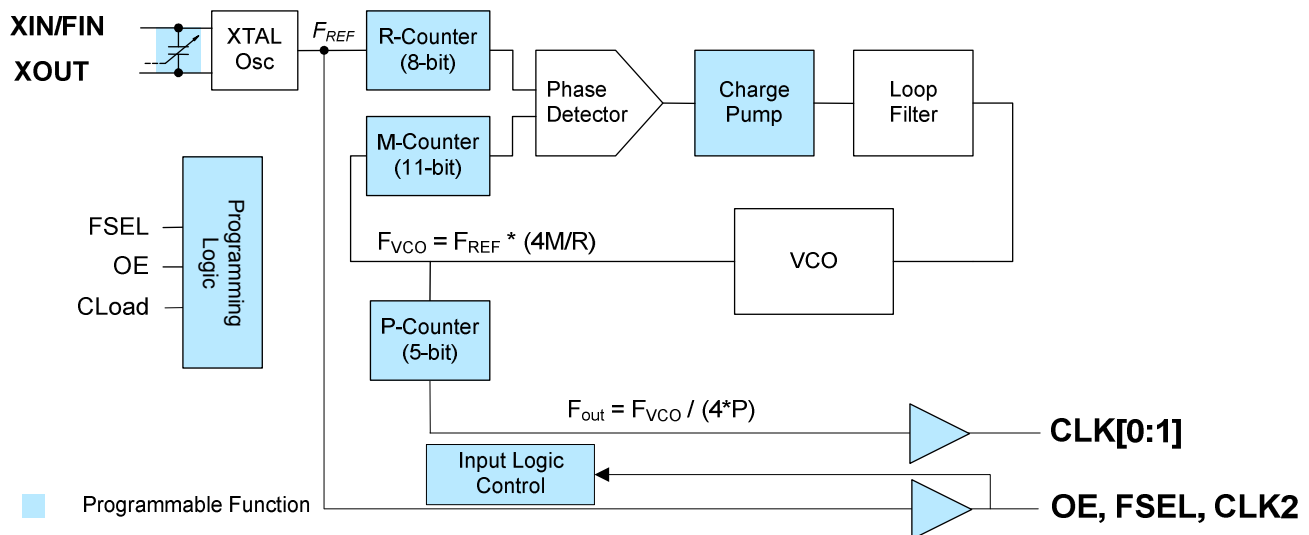

**Programmable Quick Turn Clock**

**KEY PROGRAMMING PARAMETERS**

CLK[0:2] Output Frequency	Output Drive Strength	Crystal Load	Programmable Input/Output (pin #7)	# of Register Banks	Charge-Pump Current
$F_{OUT} = F_{IN} * M / (R * P)$ where M= 11 bit R= 8 bit P= 5 bit 1. CLK[0:1]= $F_{VCO} / (4 * P)$ or $F_{VCO}/2$ 2. CLK[2]= $F_{REF}$	Std: 10mA (default)  High: 24mA	± 200ppm tuning.	One output pin can be configured as 1. CLK2 - output 2. FSEL - input 3. OE - input	2	8 levels of charge-pump current setting

**PIN DESCRIPTION**

Name	Pin #	Type	Description									
	(M)SOP-8L											
XIN, FIN	1	I	Crystal or Reference input pin									
GND	2	P	GND connection									
CLK[0:1]	3,4	O	Programmable Clock Output [note:CLK0=~CLK1]									
VDD	5	P	VDD connection									
DNC	6	-	Do No Connect									
OE, FSEL, CLK2	7	B	This programmable I/O pin can be configured as Output Enable (OE) input, Frequency Select (FSEL) input or CLK2 ( $F_{REF}$ ) output. This pin has an internal 60KΩ pull up resistor when used as OE or FSEL. <table border="1" data-bbox="678 1396 1469 1556" style="margin-left: auto; margin-right: auto;"> <thead> <tr> <th>State</th> <th>OE</th> <th>FSEL</th> </tr> </thead> <tbody> <tr> <td>0</td> <td>Tristate CLK[0:1]</td> <td>Select Bank '0'</td> </tr> <tr> <td>1 (default)</td> <td>Normal mode</td> <td>Select Bank '1'</td> </tr> </tbody> </table>	State	OE	FSEL	0	Tristate CLK[0:1]	Select Bank '0'	1 (default)	Normal mode	Select Bank '1'
State	OE	FSEL										
0	Tristate CLK[0:1]	Select Bank '0'										
1 (default)	Normal mode	Select Bank '1'										
XOUT	8	O	Crystal output pin. Do Not Connect when using $F_{IN}$									

**Programmable Quick Turn Clock**
**ELECTRICAL SPECIFICATIONS**
**ABSOLUTE MAXIMUM RATINGS**

PARAMETERS	SYMBOL	MIN.	MAX.	UNITS
Supply Voltage Range	$V_{DD}$	-0.5	4.6	V
Input Voltage Range	$V_I$	-0.5	$V_{DD}+0.5$	V
Output Voltage Range	$V_O$	-0.5	$V_{DD}+0.5$	V
Data Retention @ 85° C		10		Years
Soldering Temperature			240	°C
Storage Temperature	$T_S$	-65	150	°C
Ambient Operating Temperature*		-40	+85	°C

Exposure of the device under conditions beyond the limits specified by Maximum Ratings for extended periods may cause permanent damage to the device and affect product reliability. These conditions represent a stress rating only, and functional operations of the device at these or any other conditions above the operational limits noted in this specification is not implied. \*Operating temperature is guaranteed by design. Parts are tested to commercial grade only.

**AC SPECIFICATIONS**

PARAMETERS	CONDITIONS	MIN.	TYP.	MAX.	UNITS
Crystal Input Frequency	Fundamental Crystal	10		30	MHz
	3 <sup>rd</sup> Overtone Crystal (3.3V Operation Only)			75	
Input ( $F_{IN}$ ) Frequency				200	MHz
Input ( $F_{IN}$ ) Signal Amplitude	Internally AC coupled	0.9		$V_{DD}$	V <sub>pp</sub>
Output Frequency	At 3.3V $V_{DD}$ , 15pF Load	3		400	MHz
	At 2.5V $V_{DD}$ , 15pF Load	3		350	
OE Enable Time	OE Function; $T_a=25^\circ\text{C}$ , 15pF Load. Add one clock period to this measurement for a usable clock output.			10	ns
Settling Time	At power-up ( $V_{DD} \geq 2.25\text{V}$ )			10	ms
VDD Sensitivity	Frequency vs. $V_{DD} \pm 10\%$	-2		2	ppm
Output Rise Time	15pF Load, 10/90% $V_{DD}$ , Standard Drive		2.5	3.5	ns
	15pF Load, 10/90% $V_{DD}$ , High Drive		1.0	1.5	
Output Fall Time	15pF Load, 90/10% $V_{DD}$ , Standard Drive		2.5	3.5	ns
	15pF Load, 90/10% $V_{DD}$ , High Drive		1.0	1.5	
Duty Cycle	At $V_{DD}/2$	45	50	55	%
Max. output skew between same frequency clocks	Equal loading (15pF). Equal frequency & drive strength			500	ps
Period Jitter, peak-to-peak* (10,000 samples measured)	With capacitive decoupling between $V_{DD}$ and GND. Operating only CLK[0:1] outputs.		40		ps

\* Note: Jitter performance depends on the programming parameters.

**Programmable Quick Turn Clock**
**DC SPECIFICATIONS**

PARAMETERS	SYMBOL	CONDITIONS	MIN.	TYP.	MAX.	UNITS
Supply Current, Dynamic, with Loaded Outputs	$I_{DD}$	At 10MHz, load=15pF			15	mA
Operating Voltage	$V_{DD}$		2.25		3.63	V
Output Low Voltage	$V_{OL}$	$I_{OL} = +4mA$ (Standard Drive)			0.4	V
Output High Voltage	$V_{OH}$	$I_{OH} = -4mA$ (Standard Drive)	$V_{DD}-0.4$			V
Output Current	$I_{OSD}$	$V_{OL} = 0.4V, V_{OH} = 2.4V$ (Standard Drive)	10			mA
	$I_{OHD}$	$V_{OL} = 0.4V, V_{OH} = 2.4V$ (High Drive)	24			mA

**CRYSTAL SPECIFICATIONS**

PARAMETERS	SYMBOL	MIN.	TYP.	MAX.	UNITS
Fundamental Crystal Resonator Frequency	$F_{XIN}$	10		30	MHz
3 <sup>rd</sup> Overtone Crystal Resonator Frequency (3.3V Only)	$F_{XIN}$			75	MHz
Crystal Loading Rating (The IC can be programmed for any value in this range.)	$C_L$ (xtal)	5		20	pF
Maximum Sustainable Drive Level				500	$\mu W$
Operating Drive Level			100		$\mu W$
Crystal Shunt Capacitance	$C_0$			6	pF
Effective Series Resistance, Fundamental, 10MHz - 30MHz	ESR			30	$\Omega$
Effective Series Resistance, 3 <sup>rd</sup> Overtone, 30MHz - 50MHz [CO < 4pF, CL=5pF/8pF]	ESR			100/70	$\Omega$
Effective Series Resistance, 3 <sup>rd</sup> Overtone, 50MHz - 65MHz, [CO < 4pF, CL=5pF/8pF]	ESR			60/40	$\Omega$
Effective Series Resistance, 3 <sup>rd</sup> Overtone, 65MHz - 75MHz [CO < 4pF, CL=5pF/8pF]	ESR			45/30	$\Omega$

**Programmable Quick Turn Clock**

**TERMINATING COMPLEMENTARY LVCMOS OUTPUTS**

Figure 1 below describes how to terminate the complementary LVCMOS outputs of PhaseLink’s PL611-30 Programmable QTC clock for use with LVPECL or LVDS inputs.

The unique feature of complementary LVCMOS outputs allows great flexibility for board designers. By standardizing on one termination scheme you can use the PL611-30 for all your LVDS and LVPECL clock requirements up to 400MHz.

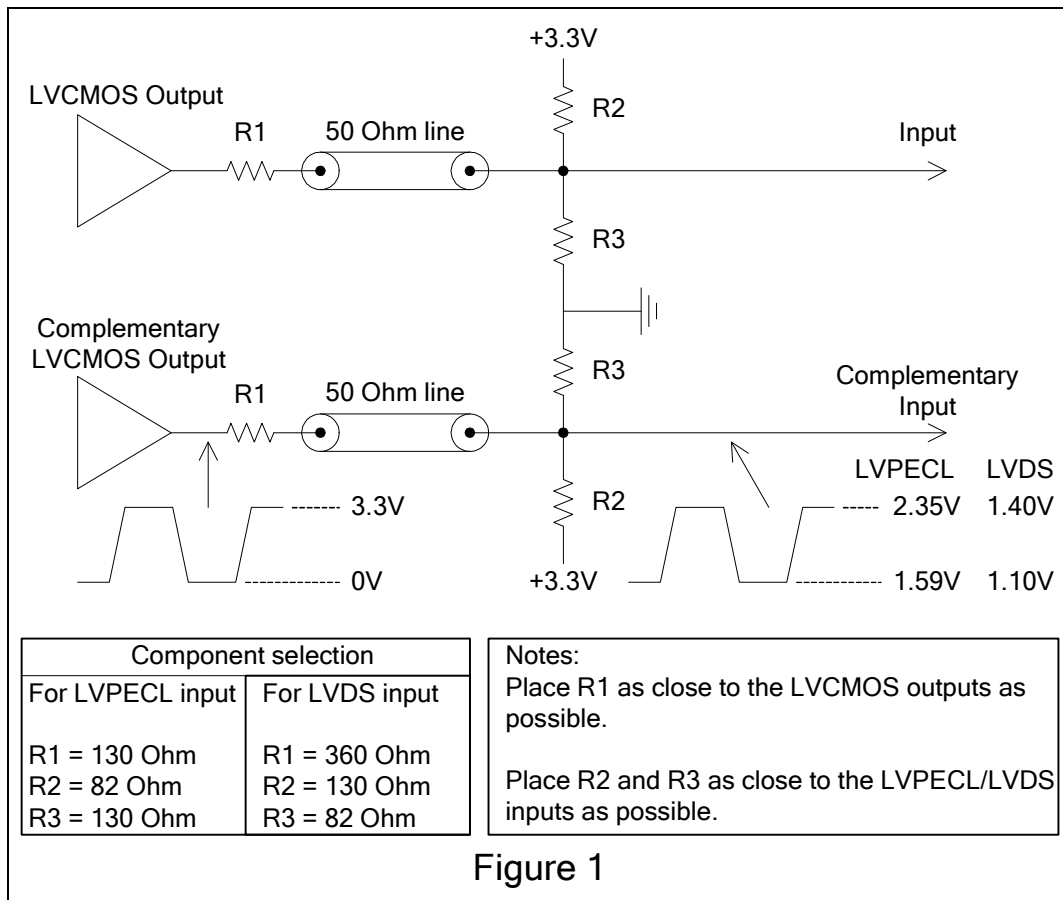

The above layout allows the PL611-30 to drive either LVPECL or LVDS inputs by simply changing the value of R1.

**Programmable Quick Turn Clock**

**PACKAGE DRAWINGS (GREEN PACKAGE COMPLIANT)**

**MSOP-8L**

Symbol	Dimension in MM	
	Min.	Max.
A	---	1.10
A1	0.05	0.15
A2	0.81	0.91
B	0.25	0.40
C	0.13	0.23
D	2.90	3.10
E	2.90	3.10
H	4.90 BSC	
L	0.445	0.648
e	0.65 BSC	

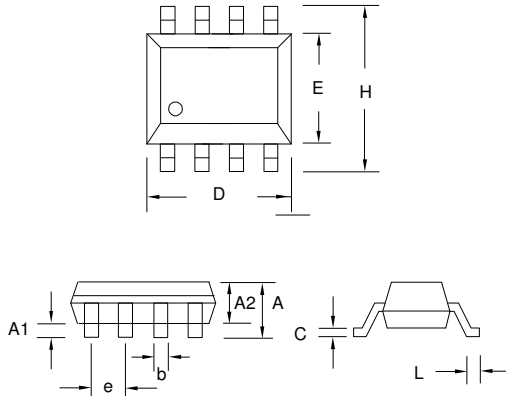

**SOP-8L**

Symbol	Dimension in MM	
	Min.	Max.
A	1.35	1.75
A1	0.10	0.25
A2	1.25	1.50
B	0.33	0.53
C	0.19	0.27
D	4.80	5.00
E	3.80	4.00
H	5.80	6.20
L	0.40	0.89
e	1.27 BSC	

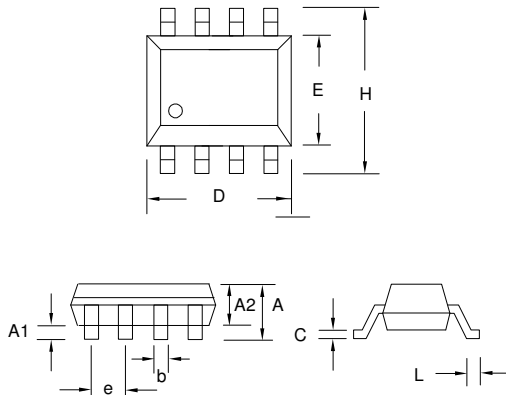

**Programmable Quick Turn Clock**

**ORDERING INFORMATION (GREEN PACKAGE COMPLIANT)**

**For part ordering, please contact our Sales Department:**

2880 Zanker Rd., San Jose, CA 95134, USA  
Tel: (408) 571-1668 Fax: (408) 517-1688

**PART NUMBER**

The order number for this device is a combination of the following:  
Part number, Package type and Operating temperature range

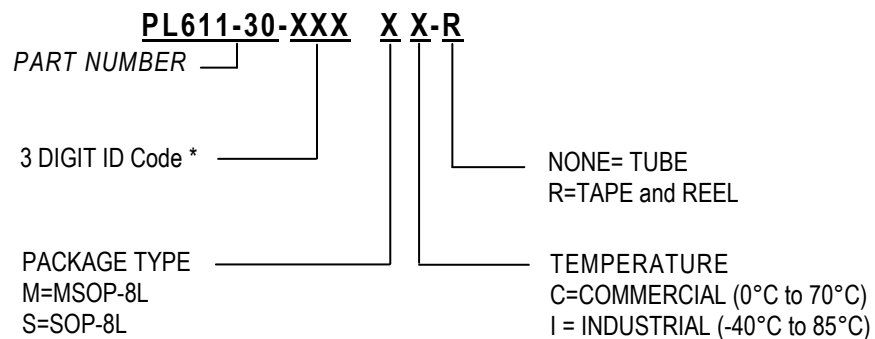

\* PhaseLink will assign a unique 3-digit ID code for each approved programmed part number.

Part / Order Number	Marking	Part / Order Number	Marking	Package Option
PL611-30-XXXMC	C3XXX	PL611-30-XXXMI	C3XXX	8-Pin MSOP (Tube)
PL611-30-XXXMC-R	LLL	PL611-30-XXXMI-R	LLLI	8-Pin MSOP (Tape and Reel)
PL611-30-XXXSC	P611-30 XXX	PL611-30-XXXSI	P611-30 XXXI	8-Pin SOP (Tube)
PL611-30-XXXSC-R	LLLLL	PL611-30-XXXSI-R	LLLLL	8-Pin SOP (Tape and Reel)

PhaseLink Corporation, reserves the right to make changes in its products or specifications, or both at any time without notice. The information furnished by Phaselink is believed to be accurate and reliable. However, PhaseLink makes no guarantee or warranty concerning the accuracy of said information and shall not be responsible for any loss or damage of whatever nature resulting from the use of, or reliance upon this product.

**LIFE SUPPORT POLICY:** PhaseLink's products are not authorized for use as critical components in life support devices or systems without the express written approval of the President of PhaseLink Corporation.