

19MHz to 800MHz Low Phase-Noise XO

FEATURES

- < 0.5ps RMS phase jitter (12kHz to 20MHz) at 622.08MHz
- 30ps max peak to peak period jitter
- 8bit Switch Capacitor for ± 50 PPM crystal CLoad tuning
 - o Load Capacitance Tuning Range: 8pF to 12pF
- Ultra Low-Power Consumption
 - o < 90 mA @622MHz PECL output
 - o < 10 μ A at Power Down (PDB) Mode
- Input Frequency:
 - o Fundamental Crystal: 19MHz to 40MHz
- Output Frequency:
 - o 19MHz to 800MHz output.
- Output types: LVPECL.
- Programmable OE input polarity selection.
- Power Supply: 3.3V, $\pm 10\%$
- Operating Temperature Ranges:
 - o Commercial: 0°C to 70°C
 - o Industrial: -40°C to 85°C
- Available in Die or Wafer

DESCRIPTION

The PL685 is a Dual LC core monolithic IC clock, capable of maintaining sub-1ps RMS phase jitter, while covering a wide frequency output range up to 800MHz, without the use of external components. The high performance and high frequency output is achieved using a low cost fundamental crystal of between 19MHz and 40 MHz. The PL685 is designed to address the demanding requirements of high performance applications such as Fiber Channel, serial ATA, Ethernet, SAN, SONET/SDH, etc.

PAD CONFIGURATION

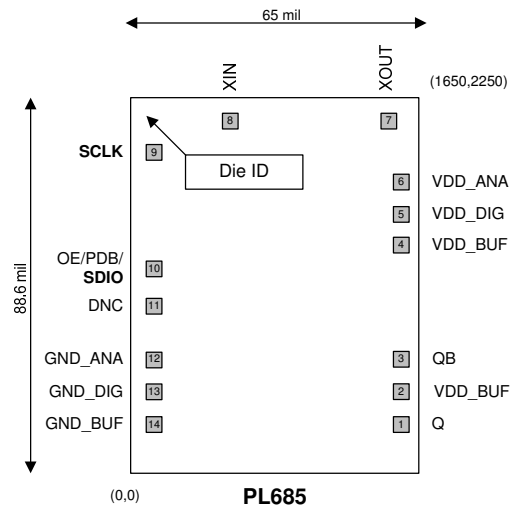

DIE SPECIFICATIONS

Name	Value
Size	65 x 88.6 mil
Reverse side	GND
Pad dimensions	80 micron x 80 micron
Thickness	8 mils

OUTPUT ENABLE CONTROL

OE Select (Programmable)	OE	State
0	0 (Default)	Output enabled
	1	Tri-state
1 (Default)	0	Tri-state
	1 (Default)	Output enabled

BLOCK DIAGRAM

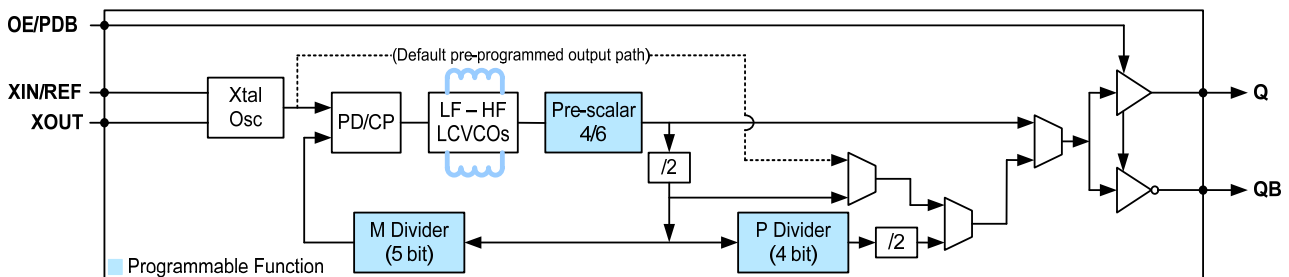

19MHz to 800MHz Low Phase-Noise XO
PAD ASSIGNMENT

Name	Pad #	X (μm)	Y (μm)	Description
Q	1	1551	220	Output buffer
VDD_BUF	2	1551	448	VDD connection for buffer circuitry
QB	3	1551	676	Output buffer
VDD_BUF	4	1551	1390	VDD connection for buffer circuitry
VDD_DIG	5	1551	1552	VDD connection for digital circuitry
VDD_ANA	6	1551	1790	VDD connection for analog circuitry
XOUT	7	1503	2156	Output connection to crystal
XIN	8	630	2156	Crystal input connection
SCLK	9	99	2060	The serial interface uses this pin for the serial clock input (SCLK), during programming.
OE/PDB/SDIO	10	99	1256	This pin may be programmed as output enable (OE), or power-down (PDB) pin. The serial interface uses this pin for the serial data input (SDIO) during programming. This pin incorporates an Internal pull-up resistor of 60KΩ for OE, PDB operations.
DNC	11	99	970	Do not connect
GND_ANA	12	99	700	GND connection for analog circuitry
GND_DIG	13	99	532	GND connection for digital circuitry
GND_BUF	14	99	364	GND connection for buffer circuitry

19MHz to 800MHz Low Phase-Noise XO

FUNCTIONAL DESCRIPTION

PL685 family of products is an advanced, programmable LCVCO clock IC that is designed to meet the most stringent performance specifications for phase noise, jitter, and power consumption.

There are two main types of VCOs, a) Ring Oscillator, b) LC Tank oscillator. An LCVCO is made up of an LC tank oscillator. Although a Ring Oscillator has very good performance, and has a good tuning range, its phase noise and jitter performance, in particular at higher frequencies, degrades.

On the other hand, an LCVCO has an outstanding phase noise and jitter performance, even at higher frequencies. PhaseLink's PL685 family of products takes advantage of this state of the art technology, and incorporates the LC tank on-chip, for optimal performance.

PL685 family of products exhibit very low phase noise/phase jitter and peak to peak jitter, wide tuning range, and very low-power. All members of the PL685 family accept a low-cost fundamental crystal input of 19MHz to 40MHz or a reference clock input of up to 800MHz and its flexible core is capable of producing any output frequency between 19MHz to 800MHz.

PLL Programming

The PLL in the PL685 family is fully programmable. The PLL is equipped with a Prescaler to divide down the VCO frequency, and a 5-bit VCO frequency feedback loop divider (M-Counter). The output of the PLL is transferred to a 4-bit post VCO divider (P-Counter), to achieve the desired output frequency.

OE (Output Enable)

The OE pin in PL685 family, through programming, can be configured to support OE pin activation with a logic '1' or logic '0', to provide you with the desired enable polarity.

OE Select (Programmable)	OE	State
0	0 (Default)	Output enabled
	1	Tri-state
1 (Default)	0	Tri-state
	1 (Default)	Output enabled

The OE pin incorporates a 60KΩ resistor to either pull-up or pull-down to the default state when the OE pin is left open.

19MHz to 800MHz Low Phase-Noise XO

ELECTRICAL SPECIFICATIONS

1. ABSOLUTE MAXIMUM RATINGS

PARAMETERS	SYMBOL	MIN	MAX	UNITS
Supply Voltage	V_{DD}		4.6	V
Input Voltage, dc	V_I	-0.5	$V_{DD}+0.5$	V
Output Voltage, dc	V_O	-0.5	$V_{DD}+0.5$	V
Storage Temperature	T_S	-65	150	°C
Ambient Operating Temperature (industrial temperature)*	T_{AI}	-40	85	°C
Ambient Operating Temperature (commercial temperature)	T_{AC}	0	70	°C
Junction Temperature	T_J		125	°C
ESD Protection, Machine Model		200		V
ESD Protection, Human Body Model		2		kV

Exposure of the device under conditions beyond the limits specified by Maximum Ratings for extended periods may cause permanent damage to the device and affect product reliability. These conditions represent a stress rating only, and functional operations of the device at these or any other conditions above the operational limits noted in this specification is not implied. *Operating temperature is guaranteed by design. Parts are tested to commercial grade only.

2. GENERAL ELECTRICAL SPECIFICATIONS

PARAMETERS	SYMBOL	CONDITIONS	MIN	TYP	MAX	UNITS
Supply Current, Dynamic	I_{DDQ}	LVPECL, 622.08MHz, 3.3V			90	mA
Supply Current, Dynamic PDB Enabled		PDB = 0, 3.3V			10	uA
Output Enable Time	t_{OE}	OE logic 0 to logic 1, $T_a=25^\circ C$. Add one clock period to this measurement for a usable clock output.			50	ns
Power Up Time	T_{PU}	PDB logic 0 to logic 1, $T_a=25^\circ C$			10	ms
Operating Voltage	V_{DD}		2.97	3.3	3.63	V
Power Up Ramp Rate	t_{PU}	Time for V_{DD} to reach 90% V_{DD} . Power ramp must be monotonic.	0.1		100	ms
Auto-Calibration Time	t_{AC}	At power up			10	ms
Output Clock Duty Cycle		@ $V_{DD} - 1.3V$	45	50	55	%

19MHz to 800MHz Low Phase-Noise XO

4. CRYSTAL SPECIFICATIONS

PARAMETERS	SYMBOL	CONDITIONS	MIN	TYP	MAX	UNITS
Crystal Resonator Frequency	F_{XIN}	Parallel Fundamental Mode	19		40	MHz
Crystal Cload	$C_{L_Crystal}$	$V_{DD} = 3.3V$, programmable	8		12	pF
Shunt Capacitance	$C_{0_Crystal}$				3.5	pF
Recommended ESR	R_E	AT cut			50	Ω

5. JITTER SPECIFICATIONS

PARAMETERS	FREQUENCY	CONDITIONS	MIN	TYP	MAX	UNITS
RMS Phase Jitter	622.08MHz	10kHz to 20MHz, $XIN=38.88MHz$		0.5		ps
Period Jitter, Pk-to-Pk	622.08MHz	10K cycles, $XIN=38.88MHz$		30		ps

6. PHASE NOISE SPECIFICATIONS

PARAMETERS	Freq. (MHz)	@ 10Hz	@ 100Hz	@ 1KHz	@ 10KHz	@ 100KHz	@ 1MHz	@ 10MHz	UNITS
Phase Noise, relative to carrier (typical)	155.52	-58	-95	-119	-124	-129	135	148	dBc/Hz
	622.08	-56	-87	-106	-111	-115	-125	-145	

7. LVPECL OUTPUTS (Q, QB)

PARAMETERS	SYMBOL	CONDITIONS	MIN	TYP	MAX	UNITS
Output High Voltage	V_{OH}	Q, QB Standard LVPECL Termination, $V_{DD} = 3.3V$	2.275	2.350	2.420	V
Output Low Voltage	V_{OL}		1.490	1.600	1.680	V
Output Frequency	F_{out}	3.3V	19		800	MHz
Output Rise, Fall Times	t_r, t_f	20% - 80% of Q_{pp}/QB_{pp}		200	300	ns
Output Voltage Swing	V_{pp}	Q, QB	550	800	900	mV

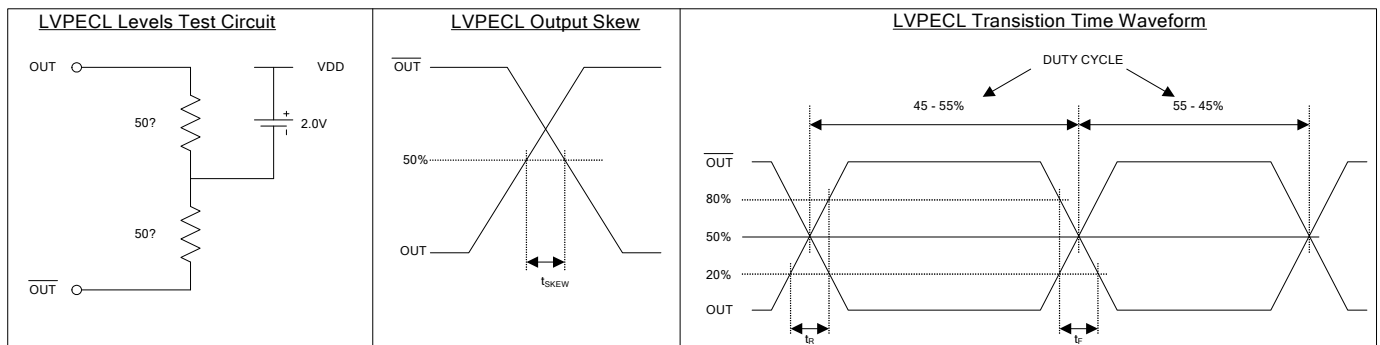

19MHz to 800MHz Low Phase-Noise XO

ORDERING INFORMATION

For part ordering, please contact our Sales Department:

2880 Zanker Road, San Jose, CA, USA
Tel: (408) 571-1668 Fax: (408) 571-1688

PART NUMBER

The order number for this device is a combination of the following:
Part number, Package type, Thickness and Operating temperature range

Part Number **PL685-88 XX**

Packaging Option

D = Die
W = Wafer

Temperature Range

C=Commercial (0°C to 70°C)

Order Number P/N	Output Frequency Range	Packaging Option
PECL		
PL685-88DC	≤800MHz	Waffle Pack (Die)
PL685-88WC	≤800MHz	Wafer

PhaseLink Corporation, reserves the right to make changes in its products or specifications, or both at any time without notice. The information furnished by Phaselink is believed to be accurate and reliable. However, PhaseLink makes no guarantee or warranty concerning the accuracy of said information and shall not be responsible for any loss or damage of whatever nature resulting from the use of, or reliance upon this product.

LIFE SUPPORT POLICY: PhaseLink's products are not authorized for use as critical components in life support devices or systems without the express written approval of the President of PhaseLink Corporation.