

40Gb/s CFP Optical Transceiver Module

SCF0400E4 Series

(40Gbps 40km, 4-lane x 10Gb/s CWDM, DFB-LD, APD-PD)

Features

- ◆ 4-lane x 10Gb/s CWDM Optical Interface
 - High quality and reliability optical sub-assemblies
 - 1310nm Un-cooled CWDM DFB-DML Transmitter with optical MUX
 - High performance APD-PD with optical DEMUX
 - 1271, 1291, 1311, 1331nm CWDM grid in ITU-T G.694.2 up to 40km over a SMF
- ◆ IEEE802.3ba Compliant
 - IEEE802.3 Clause 87 40GBASE-ER4
 - XLAUI(4x10G) Electrical Interface
 - MDIO Interface for module management
- ◆ OUT-3 Rate Operation
 - 4x10.75 Gb/s lane operation
- ◆ CFP MSA Compliant
 - Easy supply management for hot pluggability
 - CFP MSA Form Factor
 - 148pin Electrical Connector
 - Duplex SC or LC Receptacle
- ◆ Low Power Consumption
 - 3.3V single power supply
 - Power consumption less than 8W (Class 1)
- ◆ RoHS6 Compliant



Applications

- 40GE Enterprise switches and routers
- Carrier Grade 40GE Core-routers
- CWDM Point to Point and Ring Application
- Inter Rack Connection
- Other high speed data connections

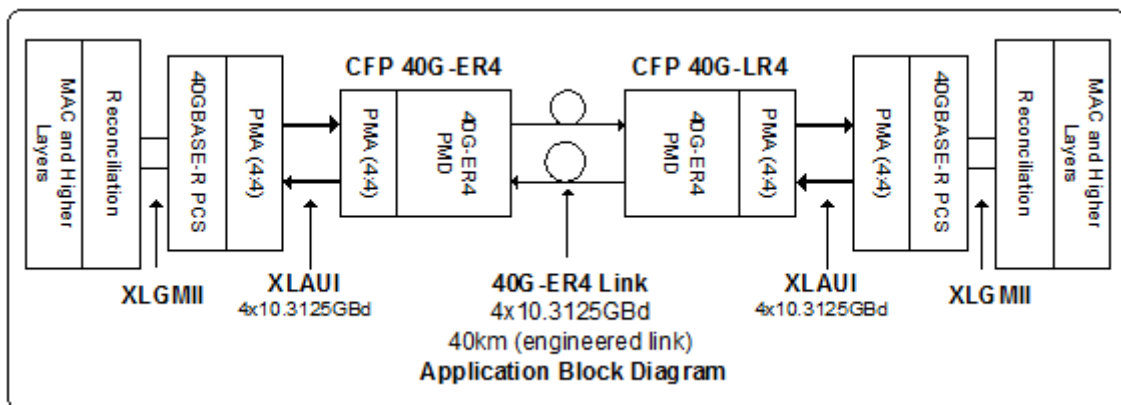

1. General Description

The SCF0400E4 is the CFP optical transceiver module which is a hot pluggable form factor designed for high speed optical networking application. The SCF0400E4 is designed for 40Gigabit Ethernet and other 40Gb/s transport application, provides IEEE802.3ba compliant XLAUI electrical interface and MDIO module management interface. The SCF0400E4 converts 4-lane 10Gb/s electrical data streams to 4-lane CWDM10Gb/s optical output signal and 4-lane CWDM 10Gb/s optical input signal to 4-lane 10Gb/s electrical data streams. This 4-lane 10Gb/s electrical signal is fully compliant with 802.3ba XLAUI specification and allows FR4 host PCB trace up to 25cm.

The high performance uncooled CWDM DFB-LD transmitters and high sensitivity APD receivers provide superior performance for 40Gigabit Ethernet applications up to 30km and 40km engineered link such as 0.4dB/km fiber loss or 2.0dB max of connector loss.

2. Functional Description

The SCF0400E4 CFP transceiver is a bi-directional module with a transmitter and receiver in one package. The SCF0400E4 contains a duplex SC or LC connector for the optical interface and a 148-pin connector for the electrical interface. Figure 2.1 shows the functional block diagram of SCF0400E4 CFP transceiver. SCF0400E4 contains 4-lane optical transmitter, 4-lane optical receiver and module management block including MDIO interface.

Transmitter Operation

The transceiver module receives 4-lane 10Gb/s XLAUI electrical inputs. CDR reshapes and retimes received electrical signal to compensate the degraded electrical signal which comes through host board and host connectors. The transmitter converts 4-lane XLAUI signals to an optical signal through 4 Laser drivers and Lasers diodes which are packaged in the Transmitter Optical Sub-Assembly (TOSA). Each Laser launches optical signal in specific wavelength specified in IEEE802.3ba 40GBASE-LR4 requirements. These 4-lane optical signals will be multiplexed into one fiber by 4 to1 WDM Optical MUX. The optical output power is held constant by an automatic power control (APC) circuit. The transmitter output can be turned off by TX_DIS hardware signal and/or through MDIO module management Interface.

Receiver Operation

The SCF0400E4 receives 4-lane CWDM optical signal. The optical signal will be de-multiplexed by 1 to 4 WDM optical DEMUX and fed into each Receiver Optical

Sub-Assembly. Each ROSA converts optical signal to electrical signal. The regenerated electrical signals are retimed and de-jittered by CDRs. CDRs generate 4-lane 10Gb/s electrical output signal which is compliant with XLAUI interface requirements. Each received optical signal is monitored by the DOM section. The monitored value is reported through the MDIO section. If one or more received optical signal is weaker than the threshold level, RX_LOS hardware alarm will be launched.

Management Data I/O (MDIO)

The SCF0400E4 supports the MDIO interface specified in IEEE802.3 Clause 45. This 2-wire management data I/O interface is provided for the module status monitoring and control. The management data clock (MDC) provides clocking for the data that is passed on the MDIO port. Five further pins allow for loading of a port address (PORT_ADDR0-4) into the module.

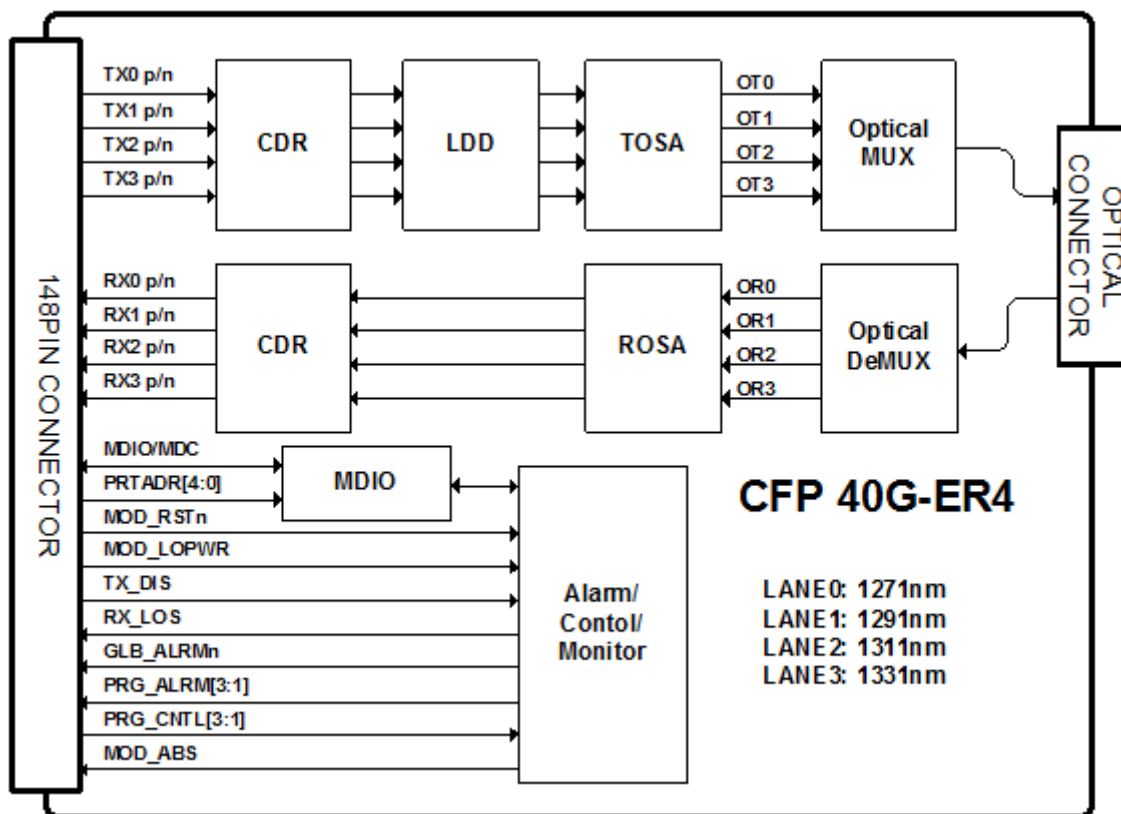
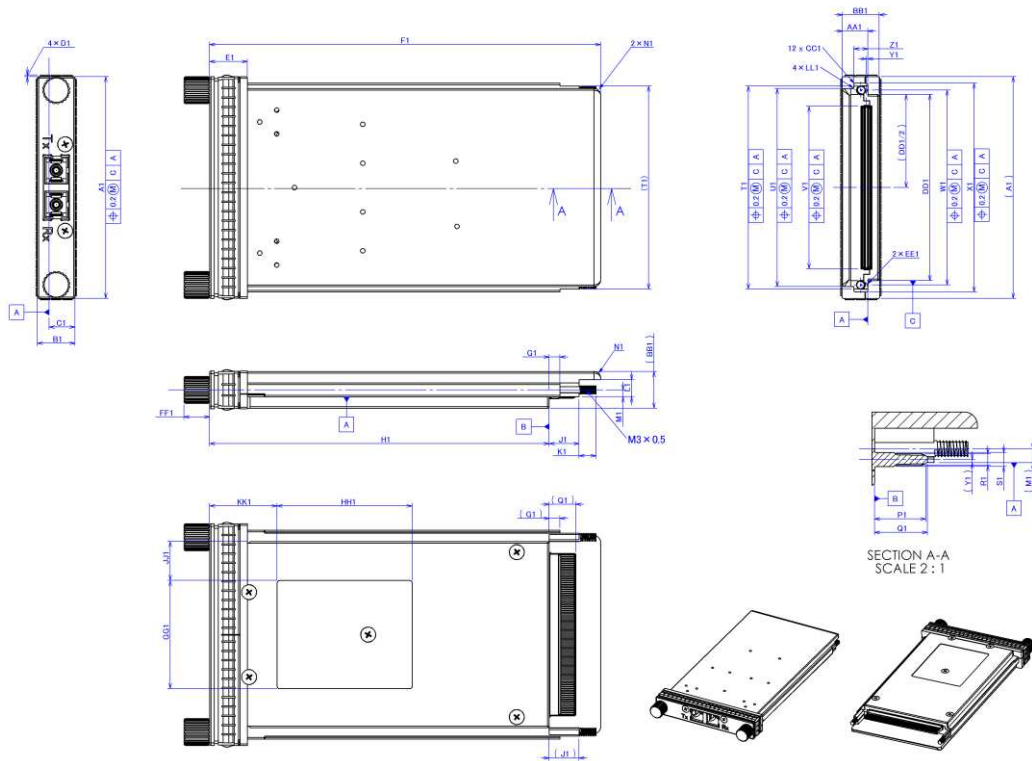

Figure 2.1. Functional Block Diagram

3. Package Dimensions

Figure 3.1 shows the package dimensions of SCF0400E4. The SCF0400E4 transceiver is designed to be compliant with CFP MSA specification.



Dimensions in mm

Figure 3.1. (a) SC with Flat Top Package Drawing

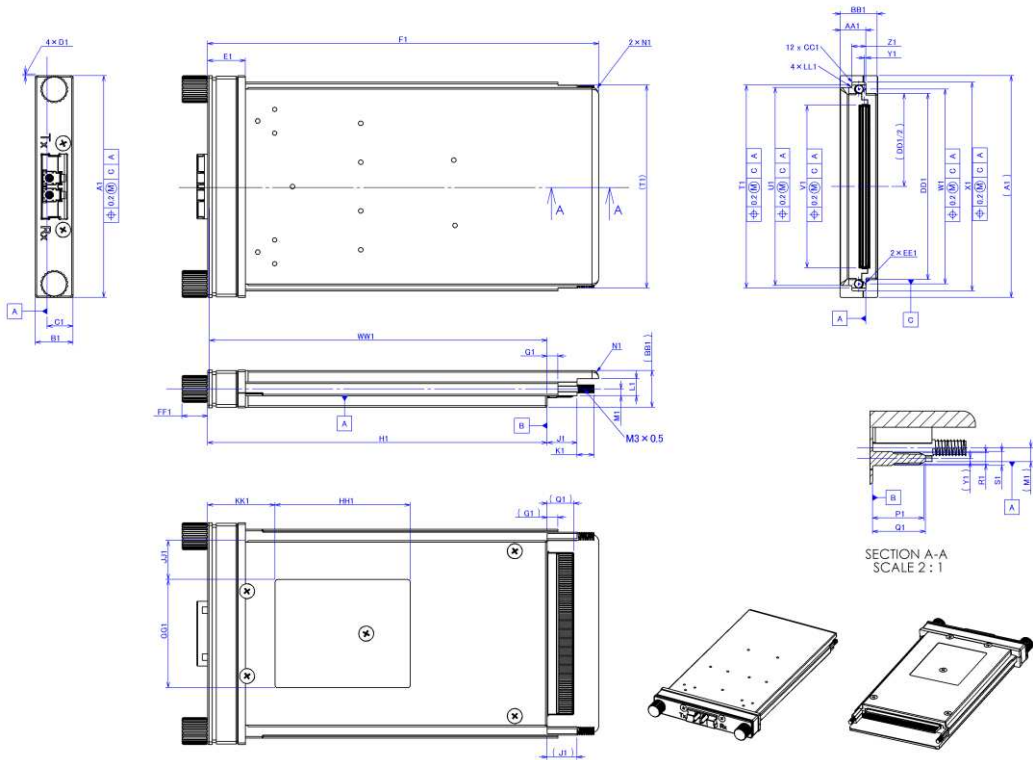

Dimensions in mm

Figure 3.1. (b) LC with Flat Top Package Drawing

Table 3.1. Package dimensions

MODULE DIMENSIONS				Note
KEY	VALUE	TOLERANCE	DESCRIPTION	
A1	82.00	±0.10	WIDTH OF MODULE FACEPLATE, OVERALL	
B1	14.00	±0.10	HEIGHT OF MODULE FACEPLATE, OVERALL	
C1	9.60	±0.20	HEIGHT OF MODULE FACEPLATE TO DATUM -A-	
D1	0.65	MIN.	HEIGHT OF EMI SPRING FINGERS	
E1	14.00	±0.50	LENGTH OF MODULE FACEPLATE, OVERALL	
F1	144.75	±0.20	LENGTH OF MODULE, OVERALL	
G1	4.00	±0.20	LENGTH OF MODULE RAIL SHOULDER	
H1	125.70	±0.20	DISTANCE FROM MODULE FACEPLATE TO HARDSTOP DATUM -B-	
J1	11.00	±0.20	DISTANCE FROM CONNECTOR PROTECTOR TO HARDSTOP DATUM -B-	
K1	6.00	±0.50	M3 THUMBSCREW THREAD LENGTH IN FULLY LOADED POSITION	
L1	6.40	±0.20	DISTANCE FROM DATUM -A- TO BOTTOM SURFACE OF MODULE TAIL	
M1	2.60	±0.20	DISTANCE FROM DATUM -A- TO CENTERLINE OF M3 THUMBSCREW HOLE	
N1	R2.00	MIN.	TOP MODULE LEAD-IN RADIUS	
P1	9.08	±0.15	LENGTH OF CONNECTOR CONTACT PIN FROM DATUM -B-	
Q1	9.80	±0.08	LENGTH OF CONNECTOR END FROM DATUM -B-	
R1	2.18	±0.08	CONNECTOR TIP THICKNESS, OVERALL	
S1	2.62	±0.08	CONNECTOR SHOULDER THICKNESS, OVERALL	
T1	75.00	±0.20	WIDTH OF MODULE CONNECTOR PROTECTOR, OVERALL	
U1	73.20	±0.20	WIDTH, TOP SHOULDER, MODULE, OVERALL	
V1	60.05	±0.08	WIDTH, CONNECTOR, OVERALL	
W1	72.00	±0.20	CENTERLINE TO CENTERLINE DISTANCE OF M3 THUMB SCREW HOLES	
X1	77.20	±0.20	WIDTH, MODULE BODY, OVERALL	
Y1	0.60	±0.15	DATUM -A- TO CENTERLINE OF CONNECTOR	
Z1	5.20	±0.20	HEIGHT, RAIL SHOULDER, MODULE, OVERALL	
AA1	9.40	±0.20	DATUM -A- TO TOP OF MODULE	
BB1	13.60	±0.20	HEIGHT, MODULE BODY, OVERALL	
CC1	R0.6	±0.10	MODULE OUTSIDE CORNER RADIUS	
DD1	68.80	±0.20	WIDTH, MODULE BOTTOM, OVERALL	
EE1	R2.60	±0.20	RADIUS, CLEARANCE, MODULE, CONNECTOR PROTECTOR FEATURE	
FF1	9.50	±0.50	THUMBSCREW HEIGHT FROM MODULE FACEPLATE TOP FRONT SURFACE	
GG1	40.00	±0.20	LABEL RECESS WIDTH	
HH1	50.00	±0.20	LABEL RECESS LENGTH	
JJ1	14.40	±0.20	LABEL RECESS TO SIDE OF MODULE	
KK1	25.00	±0.20	LABEL RECESS TO MODULE FACEPLATE	
LL1	R0.4	MAX.	MODULE INSIDE CORNER RADIUS	
WW1	125.00	±0.50	CFP module stopper to LC connector Latch	1

Note1 : Apply to LC Duplex Option

4. Pin Assignment and Pin Description

4.1. CFP Transceiver Electrical Pin Assignment

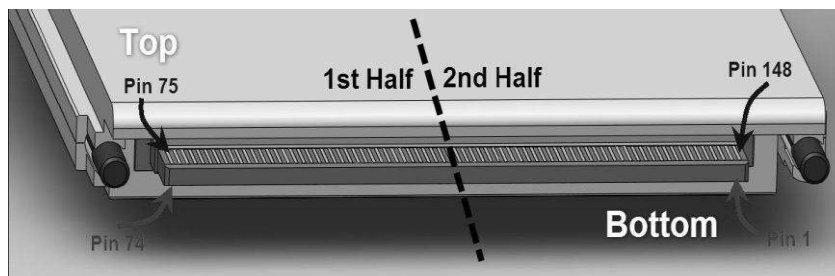

Figure 4.1. CFP Transceiver Electrical Pin Numbering

Table 4.1. CFP Transceiver Electrical Pin Assignment

Top Row 2nd Half		Bottom Row 2nd Half		Top Row 1st Half		Bottom Row 1st Half	
PIN#	Name	PIN#	Name	PIN#	Name	PIN#	Name
148	GND	1	3.3V_GND	111	GND	38	MOD_ABS
147	NC (note1)	2	3.3V_GND	110	NC	39	MOD_RSTn
146	NC (note1)	3	3.3V_GND	109	NC	40	RX_LOS
145	GND	4	3.3V_GND	108	GND	41	GLB_ALRMn
144	NC (note2)	5	3.3V_GND	107	NC	42	PRTADR4
143	NC (note2)	6	3.3V	106	NC	43	PRTADR3
142	GND	7	3.3V	105	GND	44	PRTADR2
141	NC (note2)	8	3.3V	104	NC	45	PRTADR1
140	NC (note2)	9	3.3V	103	NC	46	PRTADR0
139	GND	10	3.3V	102	GND	47	MDIO
138	NC (note2)	11	3.3V	101	NC	48	MDC
137	NC (note2)	12	3.3V	100	NC	49	GND
136	GND	13	3.3V	99	GND	50	NUC (note3)
135	NC (note2)	14	3.3V	98	NC	51	NUC (note3)
134	NC (note2)	15	3.3V	97	NC	52	GND
133	GND	16	3.3V_GND	96	GND	53	NUC (note3)
132	NC (note2)	17	3.3V_GND	95	NC	54	NUC (note3)
131	NC (note2)	18	3.3V_GND	94	NC	55	3.3V_GND
130	GND	19	3.3V_GND	93	GND	56	3.3V_GND
129	NC (note2)	20	3.3V_GND	92	NC	57	3.3V_GND
128	NC (note2)	21	NUC (note3)	91	NC	58	3.3V_GND
127	GND	22	NUC (note3)	90	GND	59	3.3V_GND
126	NC (note2)	23	GND	89	RX3n	60	3.3V
125	NC (note2)	24	NC	88	RX3p	61	3.3V
124	GND	25	NC	87	GND	62	3.3V
123	TX3n	26	GND	86	RX2n	63	3.3V
122	TX3p	27	NUC (note3)	85	RX2p	64	3.3V
121	GND	28	NUC (note3)	84	GND	65	3.3V
120	TX2n	29	NUC (note3)	83	RX1n	66	3.3V
119	TX2p	30	PRG_CNTL1	82	RX1p	67	3.3V
118	GND	31	PRG_CNTL2	81	GND	68	3.3V
117	TX1n	32	PRG_CNTL3	80	RX0n	69	3.3V
116	TX1p	33	PRG_ALRM1	79	RX0p	70	3.3V_GND
115	GND	34	PRG_ALRM2	78	GND	71	3.3V_GND
114	TX0n	35	PRG_ALRM3	77	NC	72	3.3V_GND
113	TX0p	36	TX_DIS	76	NC	73	3.3V_GND
112	GND	37	MOD_LOPWR	75	GND	74	3.3V_GND

- 1: These pins are not used for this product. These pins are internally terminated by AC 100ohm.
- 2: These pins are not used for this product. The paired pins are internally terminated by AC 100ohm
- 3: These pins are internally used and NOT allowed to connect any signal, power supply and GND.

4.2. Host PCB CFP Foot Print

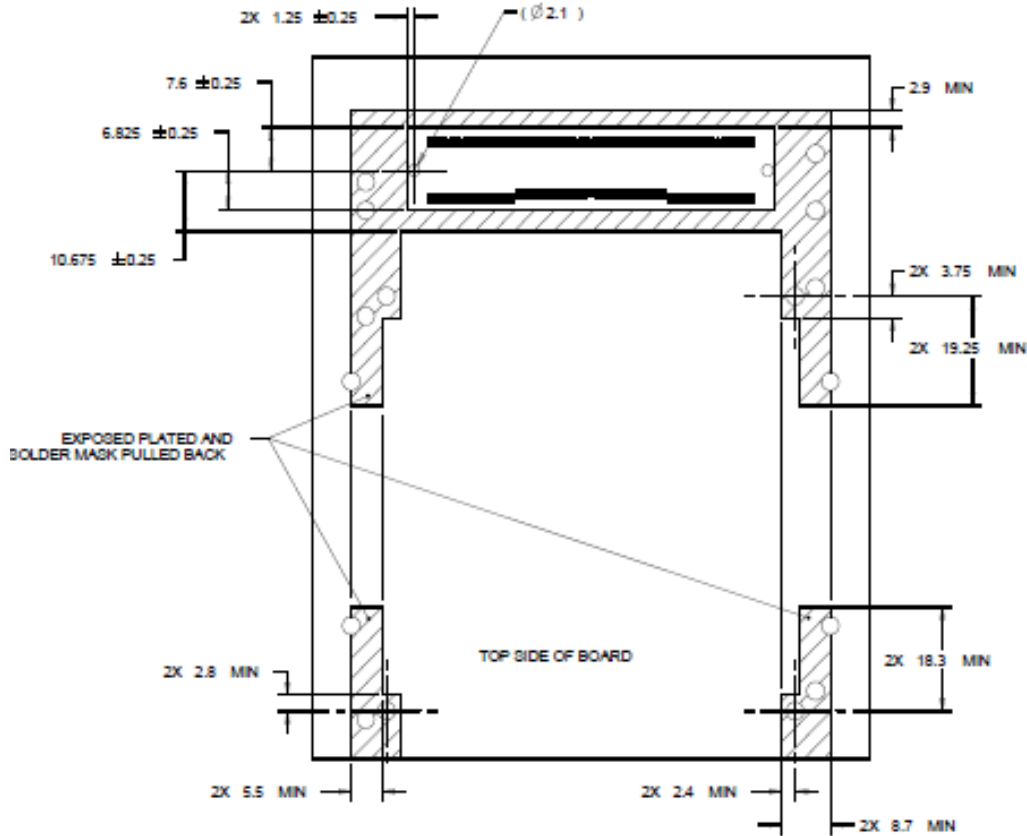

Figure 4.2. Host PCB CFP Foot Print

Table 4.2. Host Connector Assembly Information

Part Name	Supplier	Part Number
External Bracket Assy.	Tyco Electronics	2057626-1
Guide Rail	Tyco Electronics	2057592-2
Host Connector Cover Assy.	Tyco Electronics	2057631-1
Backer Plate Assy.	Tyco Electronics	2057930-1
Host Connector	Tyco Electronics	2057630-1

4.3. Pin Descriptions

Table 4.3. Pin Description

PIN#	Name	I/O	Logic	Description
1	3.3V_GND			3.3V Module Supply Voltage Return Ground, can be separate or tied together with Signal Ground
2	3.3V_GND			
3	3.3V_GND			
4	3.3V_GND			
5	3.3V_GND			
6	3.3V			3.3V Module Supply Voltage
7	3.3V			3.3V Module Supply Voltage
8	3.3V			3.3V Module Supply Voltage
9	3.3V			3.3V Module Supply Voltage
10	3.3V			3.3V Module Supply Voltage
11	3.3V			3.3V Module Supply Voltage
12	3.3V			3.3V Module Supply Voltage
13	3.3V			3.3V Module Supply Voltage
14	3.3V			3.3V Module Supply Voltage
15	3.3V			3.3V Module Supply Voltage
16	3.3V_GND			3.3V Module Supply Voltage Return Ground, can be separate or tied together with Signal Ground
17	3.3V_GND			
18	3.3V_GND			
19	3.3V_GND			
20	3.3V_GND			
21	NUC			Module Vendor I/O. Must No Connect at host board
22	NUC			Module Vendor I/O. Must No Connect at host board
23	GND			
24	NC			Not Connected Internally
25	NC			Not Connected Internally
26	GND			
27	NUC			Module Vendor I/O. Must No Connect at host board
28	NUC			Module Vendor I/O. Must No Connect at host board
29	NUC			Module Vendor I/O. Must No Connect at host board
30	PRG_CNTL1	I	LVC MOS w/ PUR	Programmable Control 1 set over MDIO, MSA Default: TRXIC_RSTn, TX & RX ICs reset, "0": reset, "1" or NC: enabled = not used
31	PRG_CNTL2	I	LVC MOS w/ PUR	Programmable Control 2 set over MDIO, MSA Default: Hardware Interlock LSB, "00": ≤8W, "01": ≤16W, "10": ≤24W, "11" or NC: ≤32W = not used
32	PRG_CNTL3	I	LVC MOS w/ PUR	Programmable Control 2 set over MDIO, MSA Default: Hardware Interlock LSB, "00": ≤8W, "01": ≤16W, "10": ≤24W, "11" or NC: ≤32W = not used
33	PRG_ALARM1	O	LVC MOS	Programmable Alarm 1 set over MDIO, MSA Default: HIPWR_ON, "1": module power up completed, "0": module not high powered up
34	PRG_ALARM2	O	LVC MOS	Programmable Alarm 2 set over MDIO, MSA Default: MOD_READY, "1": Ready, "0": not Ready.
35	PRG_ALARM3	O	LVC MOS	Programmable Alarm 3 set over MDIO, MSA Default: MOD_FAULT, fault detected, "1": Fault, "0": No Fault
36	TX_DIS	I	LVC MOS w/ PUR	Transmitter Disable for all lanes, "1" or NC = transmitter disabled, "0" = transmitter enabled
37	MOD_LOPWR	I	LVC MOS w/ PUR	Module Low Power Mode. "1" or NC: module in low power (safe) mode, "0": power-on enabled

Table 4.3. Pin Description (Continued)

PIN#	Name	I/O	Logic	Description
38	MOD_ABS	O	GND	Module Absent. "1" or NC: module absent, "0": module present, Pull Up Resistor on Host
39	MOD_RSTn	I	LVC MOS w/ PUR	Module Reset. "0" resets the module, "1" or NC = module enabled, Pull Down Resistor in Module
40	RX_LOS	O	LVC MOS	Receiver Loss of Optical Signal, "1": low optical signal, "0": normal condition
41	GLB_ALRMn	O	LVC MOS	Global Alarm. "0": alarm condition in any MDIO Alarm register, "1": no alarm condition, Open Drain, Pull Up Resistor on Host
42	PRTADR4	I	1.2V CMOS	MDIO Physical Port address bit 4
43	PRTADR3	I	1.2V CMOS	MDIO Physical Port address bit 3
44	PRTADR2	I	1.2V CMOS	MDIO Physical Port address bit 2
45	PRTADR1	I	1.2V CMOS	MDIO Physical Port address bit 1
46	PRTADR0	I	1.2V CMOS	MDIO Physical Port address bit 0
47	MDIO	I/O	1.2V CMOS	Management Data I/O bi-directional data (electrical specs as per 802.3ae and ba)
48	MDC	I	1.2V CMOS	Management Data Clock (electrical specs as per 802.3ae and ba)
49	GND			
50	NUC			Module Vendor I/O. Must No Connect at host board
51	NUC			Module Vendor I/O. Must No Connect at host board
52	GND			
53	NUC			Module Vendor I/O. Must No Connect at host board
54	NUC			Module Vendor I/O. Must No Connect at host board
55	3.3V_GND			3.3V Module Supply Voltage Return Ground, can be separate or tied together with Signal Ground
56	3.3V_GND			
57	3.3V_GND			
58	3.3V_GND			
59	3.3V_GND			
60	3.3V			3.3V Module Supply Voltage
61	3.3V			3.3V Module Supply Voltage
62	3.3V			3.3V Module Supply Voltage
63	3.3V			3.3V Module Supply Voltage
64	3.3V			3.3V Module Supply Voltage
65	3.3V			3.3V Module Supply Voltage
66	3.3V			3.3V Module Supply Voltage
67	3.3V			3.3V Module Supply Voltage
68	3.3V			3.3V Module Supply Voltage
69	3.3V			3.3V Module Supply Voltage
70	3.3V_GND			3.3V Module Supply Voltage Return Ground, can be separate or tied together with Signal Ground
71	3.3V_GND			
72	3.3V_GND			
73	3.3V_GND			
74	3.3V_GND			

Table 4.3. Pin Description (Continued)

PIN#	Name	I/O	Logic	Description
75	GND			
76	NC			Not Connected Internally
77	NC			Not Connected Internally
78	GND			
79	RX0p	O	HS I/O	Lane 0 Receiver Output (Positive)
80	RX0n	O	HS I/O	Lane 0 Receiver Output (Negative)
81	GND			
82	RX1p	O	HS I/O	Lane 1 Receiver Output (Positive)
83	RX1n	O	HS I/O	Lane 1 Receiver Output (Negative)
84	GND			
85	RX2p	O	HS I/O	Lane 2 Receiver Output (Positive)
86	RX2n	O	HS I/O	Lane 2 Receiver Output (Negative)
87	GND			
88	RX3p	O	HS I/O	Lane 3 Receiver Output (Positive)
89	RX3n	O	HS I/O	Lane 3 Receiver Output (Negative)
90	GND			
91	NC			Not Connected Internally
92	NC			Not Connected Internally
93	GND			
94	NC			Not Connected Internally
95	NC			Not Connected Internally
96	GND			
97	NC			Not Connected Internally
98	NC			Not Connected Internally
99	GND			
100	NC			Not Connected Internally
101	NC			Not Connected Internally
102	GND			
103	NC			Not Connected Internally
104	NC			Not Connected Internally
105	GND			
106	NC			Not Connected Internally
107	NC			Not Connected Internally
108	GND			
109	NC			Not Connected Internally
110	NC			Not Connected Internally
111	GND			

Table 4.3. Pin Description (Continued)

PIN#	Name	I/O	Logic	Description
112	GND			
113	TX0p	I	HS I/O	Lane 0 Transmitter Input (Positive)
114	TX0n	I	HS I/O	Lane 0 Transmitter Input (Negative)
115	GND			
116	TX1p	I	HS I/O	Lane 1 Transmitter Input (Positive)
117	TX1n	I	HS I/O	Lane 1 Transmitter Input (Negative)
118	GND			
119	TX2p	I	HS I/O	Lane 2 Transmitter Input (Positive)
120	TX2n	I	HS I/O	Lane 2 Transmitter Input (Negative)
121	GND			
122	TX3p	I	HS I/O	Lane 3 Transmitter Input (Positive)
123	TX3n	I	HS I/O	Lane 3 Transmitter Input (Negative)
124	GND			
125	NC			Internally terminated with AC 100 Ohm
126	NC			
127	GND			
128	NC			Internally terminated with AC 100 Ohm
129	NC			
130	GND			
131	NC			Internally terminated with AC 100 Ohm
132	NC			
133	GND			
134	NC			Internally terminated with AC 100 Ohm
135	NC			
136	GND			
137	NC			Internally terminated with AC 100 Ohm
138	NC			
139	GND			
140	NC			Internally terminated with AC 100 Ohm
141	NC			
142	GND			
143	NC			Not Connected Internally
144	NC			Not Connected Internally
145	GND			
146	NC			Internally terminated with AC 100 Ohm
147	NC			
148	GND			

5. Absolute Maximum Ratings and Recommended Operating Conditions

Table 5.1. Absolute Maximum Ratings

Parameter	Symbol	Min	Max	Unit	Note
Storage Temperature	T _{st}	-40	85	degC	
Relative Humidity (non-condensation)	RH		85	%	
Operating Case Temperature	T _{opc}	-5	70	degC	
Supply Voltage	V _{cc}	-0.3	3.6	V	
Voltage on any XLAUI pin	V _{XAUI}	-0.3	1.9	V	
Voltage on any 3.3V LVCMOS pin	V _{LVCMOS}	-0.3	V _{cc} +0.3	V	
Voltage on any 1.2V LVCMOS pin	V _{LVCMOS}	-0.3	1.65	V	
Receiver Input Optical Power each lane	M _{ip}		3.8	dBm	

Table 5.2. Recommended Operating Conditions and supply requirements

Parameter	Symbol	Min	Max	Unit	Note
Operating Case Temperature	T _{opc}	-5	70	degC	
Relative Humidity (non-condensing)	R _{hop}		85	%	
Power Supply Voltage	V _{cc}	3.135	3.465	V	
Power Supply Current for 3.3V			2.5	A	
Total Power Dissipation	P _w	-	8	W	
Low Power Mode dissipation	P _{low}	-	2	W	
In-rush Current (Class 1 and 2)	I _{inrush}	-	50	mA/us	
Turn-off rush Current (Class 1 and 2)	I _{turnoff}	-50	-	mA/us	
Power Supply Noise	V _{rip}	-	2	%	DC-1MHz
		-	3	%	1-10MHz

6. Electrical Interface

6.2. Electrical High Speed I/O Interface

Table 6.1.1. XLAUI Input Interface

XLAUI Receiver Parameters	symbol	Min	Typ	Max	Units	Note
Signal Rate Per Lane			10.3125		Gb/s	
Signal Rate tolerance		-100		100	ppm	
AC Common Mode Voltage Tolerance, RMS	CMVLTac			20	mV	
Minimum Differential Input Return Loss	Rldiff	IEEE802.3ba Equation 83B-5			dB	
Total Input Jitter Tolerance	Tjin			0.62	UI	
Deterministic Input Jitter Tolerance	Tdin			0.42	UI	
Transmitter Input Eye Mask (X1, X2)		(0.31, 0.5)			UI	1
Transmitter Input Eye Mask (Y1, Y2)		(42.5, 425)			mV	1

Table 6.1.2 XLAUI Output Interface

XLAUI Driver Parameters	symbol	Min	Typ	Max	Units	Note
Signal Rate Per Lane			10.3125		Gb/s	
Signal Rate tolerance		-100		100	ppm	
Single-end Output Voltage	Vosingle	-0.4		4	V	
Output AC Common Mode Voltage, RMS	Vocomac			15	mV	
Output Rise and Fall Time (20%-80%)	Trftl	24			ps	
Minimum Differential Output Return Loss	Rldiff	IEEE802.3ba Equation 83B-6			dB	
Total Output Jitter	Tjo			0.4	UI	
Deterministic Output Jitter	Tdo			0.25	UI	
Receiver Output Eye Mask (X1, X2)		(0.2, 0.5)			UI	2
Receiver Output Eye Mask (Y1, Y2)		(136, 380)			mV	2

1: Refer to Figure 6.1.1

2: Refer to Fig.6.1.2

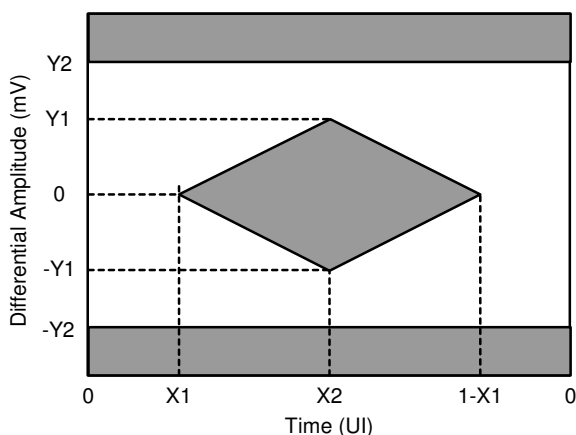

Figure 6.1.1. XLAUI Receiver Eye Mask

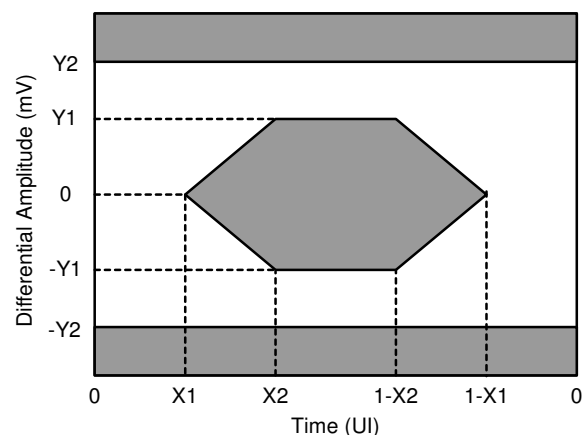

Figure 6.1.2. XLAUI Transmitter Eye Mask

6.2. Electrical Low Speed I/O Interface

Table 6.2.1. 3.3V CMOS DC parameters

(MOD_RSTn, MOD_LOPWR, TX_DIS, PRG_CNTL, MOD_ABS, RX_LOS, GLB_ALRMn, PRG_ALARM)

Parameter	symbol	Min	Typ	Max	Units	Note
Input High Voltage	Vih	2		Vcc+0.3	V	
Input Low Voltage	Vil	-0.3		0.8	V	
Input Leakage Current	IIN	-10		10	μA	
Output High Voltage (IOH=-100uA)	Voh	Vcc-0.2		Vcc+0.3	V	
Output Low Voltage (IOL=100uA)	Vol	-0.3		0.2	V	
Minimum Pulse Width of Control Pin Signal	t_CNTL	100			μS	

Table 6.2.2. 1.2V CMOS DC parameters (MDIO, MDC, PRTADR4:0)

Parameter	symbol	Min	Typ	Max	Units	Note
Input High Voltage	Vih	0.84		1.5	V	
Input Low Voltage	Vil	-0.3		0.36	V	
Input Leakage Current	IIN	-100		100	μA	
Output High Voltage	Voh	1.0		1.5	V	
Output Low Voltage	Vol	-0.3		0.2	V	
Output high current (Vi = 1.0V)	Iioh			-4	mA	
Output low current (Vi = 0.2V)	Iol	4			mA	
Input Capacitance	Ci			10	pF	

Table 6.2.3. MDIO and MDC AC parameters

Parameter	symbol	Min	Max	Units	Note
Hardware MOD_LOPWR assert	t_MOD_LOPWR_assert		1	ms	
Hardware MOD_LOPWR deassert	t_MOD_LOPWR_deassert		2000	ms	
Receiver Loss of Signal Assert Time	t_loss_assert		100	μs	
Receiver Loss of Signal De-Assert Time	t_loss_deassert		100	μs	
Global Alarm Assert Delay Time	GLB_ALRMn_assert		150	ms	
Global Alarm De-Assert Delay Time	GLB_ALRMn_deassert		150	ms	
Initialization time from Reset	t_initialize		2.5	s	
Transmitter Disabled (TX_DIS asserted)	t_deassert		100	μs	
Transmitter Enabled (TX_DIS de-asserted)	t_assert		100	ms	

Table 6.2.4. MDIO and MDC AC parameters

Parameter	symbol	Min	Typ	Max	Units	Note
MDC clock Frequency	fMDC	0.1		4	MHz	
MDC clock period	tprd	250		10000	ns	
MDIO data hold time	Thold	10			ns	
MDIO data setup time	Tsetup	10			ns	
MDC high and low time	twidth	40		60	%	
		160			ns	
Delay from MDC rising edge to MDIO data change	Tdelay			175	ns	
MDIO/MDC termination in CFP	Zt	100			kOhm	

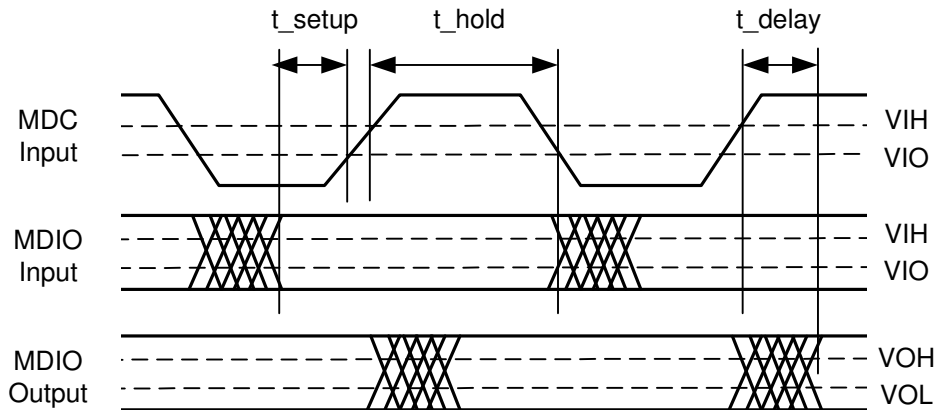

Table 6.2.1. MDIO and MDC AC parameters

7 Optical Interface

Table 7.1. Optical Interface for 40GBASE-ER4

CFP 40GBASE-ER4						
Parameter	Symbol	Min	Typical	Max	Unit	Note
Fiber type			SMF			
Signaling speed, each lane		10.3125 ± 100ppm			Gbps	
Operating Reach		10 – 30 (40)			km	1
Lane wavelength (range): L0	L0	1264.5	1271	1277.5	nm	
Lane wavelength (range): L1	L1	1284.5	1291	1297.5	nm	
Lane wavelength (range): L2	L2	1304.5	1311	1317.5	nm	
Lane wavelength (range): L3	L3	1324.5	1331	1337.5	nm	
Transmitter Optical Interface						
Parameter	Symbol	Min	Typical	Max	Unit	Note
SMSR	SMSR	30		-	dB	
Total average launch power(max)	Po2	9.8			dBm	
Average launch power, each lane (max) 1	Polnmax	3.8			dBm	
Average launch power, each lane (min) 1	Polnmin	-1.1			dBm	
OMA, each lane (max) 1	TOMAmx1	4.6			dBm	
OMA, each lane (min) 1	TOMAmn1	0.8			dBm	
DifferenceOMA between any two lanes (max)	TdOMA	3.8			dB	
OMA - TDP, each lane (min)	OMA-tdp	0			dBm	
Transmitter and Dispersion Penalty (TDP), each lane (max)	TDP	2.6			dB	
Average power Disabled, each lane (max)	Podis	-30			dBm	
Extinction Ratio 1	ER2	6	7	-	dB	
RIN12OMA	RIN			-128	dB/Hz	
Optical Return Loss Tolerance	Torlt			20	dB	
Transmitter Reflectance	TORF			-12	dB	
Eye Mask {X1, X2, X3, Y1, Y2, Y3}	PM	{0.25, 0.4, 0.45, 0.25, 0.28, 0.4}				2
Receiver Optical Interface						
Parameter	Symbol	Min	Typical	Max	Unit	Note
Damage threshold	Pindm	3.8			dBm	
Average receive power, each lane (max) 1	Pinmx1	-1.3			dBm	
Receive power, each lane (OMA) (max)	ROMAmx	-0.5			dBm	
Difference in OMA between any two lanes	RdOMA			4.2	dB	
Receiver reflectance	RORF	-26			dB	
Receiver Sensitivity (OMA) , each lane	ROMAmin	-18			dBm	3
Stressed Sensitivity in OMA	OMAst	-15.8			dBm	
Vertical eye closure penalty 2.2dB						
Stressed eye jitter 0.3 UI						
Rx-Lane LOS Assert	LOSas	-30	-28	-20	dBm	
Rx-Lane LOS Deassert	LOSdea		-26.5	-17	dBm	
Rx-Lane LOS Hysteresis	LOShys	0.5			dB	
Receiver reflectance (max)	ORL			-26	dB	

1: 40km is engineered link with 0.4dB/km fiber loss and 2.0dB connector loss

2: Refer to Fig.7.1,

3: BER <10⁻¹²

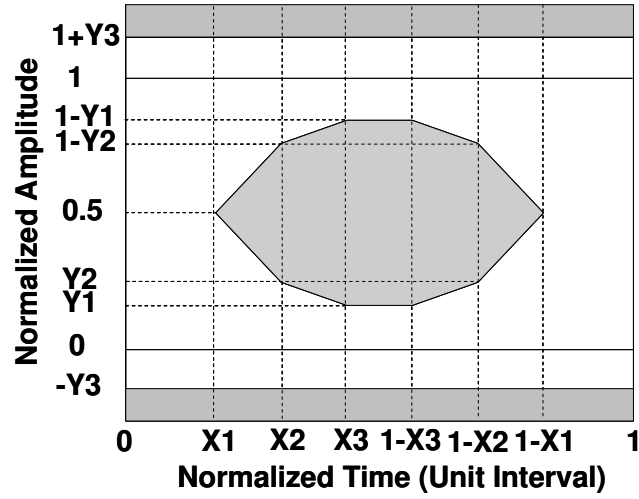
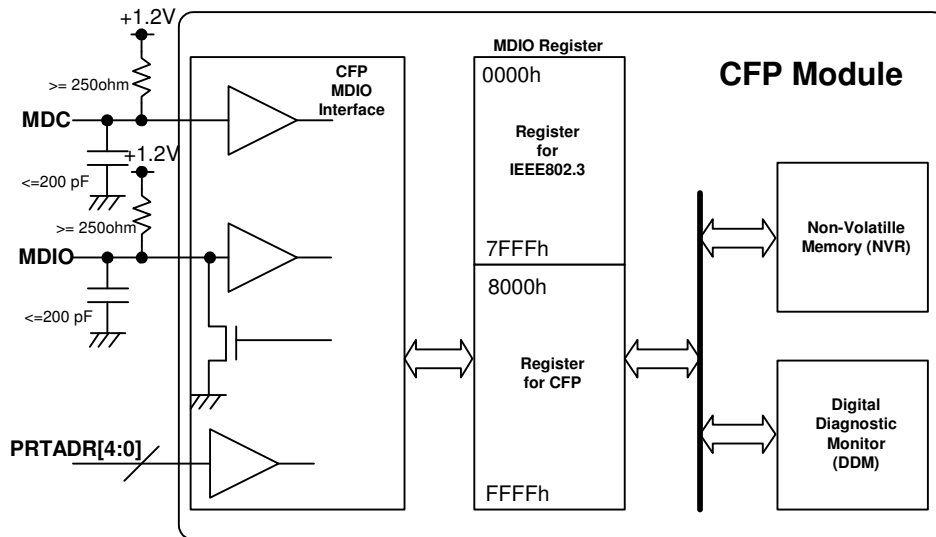

Fig 7.1. Transmission eye mask definition

8 MDIO and Non-Volatile Registers Map

8.1 MDIO Interface and CFP Register Allocation



Note: Capacitor represents stray capacity
> 600ohm pull-up is preferred

Figure 8.1. CFP MDIO Interface

Table 8.1. CFP Register Allocation

Starting Address in Hex	Ending Address in Hex	Access Type	Allocated Size	Data Bit Width	Table Name and Description
0000	7FFF	N/A	32768	N/A	Reserved for IEEE 802.3 Use.
8000	807F	RO	128	8	CFP NVR 1. Basic ID registers.
8080	80FF	RO	128	8	CFP NVR 2. Extended ID registers.
8100	817F	RO	128	8	CFP NVR 3. Network lane specific registers.
8180	81FF	RO	128	8	CFP NVR 4.
8200	83FF	RO	4x128	N/A	MSA Reserved.
8400	847F	RO	128	8	Vendor NVR 1. Vendor data registers.
8480	84FF	RO	128	8	Vendor NVR 2. Vendor data registers.
8500	86FF	RO	6x128	N/A	Reserved by CFP MSA.
8800	887F	R/W	128	8	User NVR 1. User data registers.
8880	88FF	R/W	128	8	User NVR 2. User data registers.
8900	8FFF	RO	14x128	N/A	Reserved by CFP MSA.
9000	9FFF	RO	4096	N/A	Reserved for vendor private use.
A000	A07F	R/W	128	16	CFP Module VR 1. CFP Module level control / DDM registers.
A080	A0FF	RO	128	16	Reserved by CFP MSA.
A100	A1FF	RO	2x128	N/A	Reserved by CFP MSA.
A200	A27F	R/W	128	16	Network Lane VR 1. Network lane specific registers.
A280	A2FF	R/W	128	16	Network Lane VR 2. Network lane specific registers.
A300	A3FF	RO	2x128	N/A	Reserved by CFP MSA.
A400	A47F	R/W	128	16	Host Lane VR 1. Host lane specific registers.
A480	AFFF	RO	23x128	N/A	Reserved by CFP MSA.
B000	FFFF	RO	5x4096	N/A	Reserved by CFP MSA.

8.2 Non-Volatile Register (NVR) Map

Table 8.2.1. CFP NVR-1

Hex Addr	Size	Access Type	Bit	Register Name Bit Filed Name	Value		Description	LSB Unit	
					Value	Hex			
Base ID Information									
8000	1	RO		Module Identifier		0Eh	0Eh: CFP	N/A	
8001	1	RO		Extended Identifier		22h	00100010	N/A	
			7	Power Class	0		00b: Class 1 (= < 8W)	N/A	
			6		0			N/A	
			5	Lane Ratio Type	1		10b: n : n Parallel Type	N/A	
			4		0			N/A	
			3		0			N/A	
			2	WDM Type	0		001b: CWDM	N/A	
			1		1			N/A	
			0	CLEI Presence	0		0: No CLEI code present	N/A	
8002	1	RO		Connector Type Code		01h	01h: SC	N/A	
8003	1	RO		Ethernet Application Code		00h	00h: Undefined type	N/A	
8004	1	RO		Fiber Channel Application Code		00h	00h: Undefined type	N/A	
8005	1	RO		Copper Link Application Code		00h	00h: Undefined type	N/A	
8006	1	RO		SONET/SDH Application Code		00h	00h: Undefined type	N/A	
8007	1	RO		OTN Application Code		00h	00h: Undefined type	N/A	
8008	1	RO		Additional Capable Rates Supported		04h	00000100	N/A	
			7	Reserved	0		0: Reserved	N/A	
			6	Reserved	0		0: Reserved	N/A	
			5	Reserved	0		0: Reserved	N/A	
			4	111.8 Gbps	0		0: Not supported	N/A	
			3	103.125 Gbps	0		0: Not supported	N/A	
			2	41.25 Gbps	1		1: Supported	N/A	
			1	43 Gbps	0		0: Not supported	N/A	
0	39.8 Gbps	0		0: Not supported	N/A				
8009	1	RO		Number of Lanes Supported		44h	01000100	N/A	
			7		0			N/A	
			6	Number of Network Lanes	1		0100: 4 lanes		
			5		0				
			4		0				
			3		0				
			2	Number of Host Lanes	1		0100: 4 lanes		
			1		0				
0	0								
0	0				N/A				
800A	1	RO		Media Properties		11h	00010001	N/A	
			7	Media Type	0		00b: SMF		
			6		0				
			5	Directionality	0		0: Normal		
			4	Optical Mux and DeMux	1		1: with optical MUX/DEMUX		
			3	Active Fiber per Connector	0			N/A	
			2		0		0001b: 1 TX lane and 1 RX lane	N/A	
			1		0			N/A	
0	0				N/A				
0	1								
800B	1	RO		Maximum Network Lane Bit Rate		34h	34h: 10.3125Gbps / 0.2	0.2 Gbps	
800C	1	RO		Maximum Host Lane Bit Rate		34h	34h: 10.3125Gbps / 0.2	0.2 Gbps	
800D	1	RO		Maximum Single Mode Optical Fiber		28h	28h: 40km	1 km	
800E	1	RO		Maximum Multi-Mode Optical Fiber		00h	0: Not supported	10 m	
800F	1	RO		Maximum Copper Cable Length		00h	0: Not supported	1 m	
8010	1	RO		Transmitter Spectral Characteristics 1		01h	00000001	N/A	
			7	Reserved	0		0: Reserved	N/A	
			6		0		0: Reserved		
			5		0		0: Reserved		
			4	Number of Active Transmit Fibers	0			00001b: 1 Fiber	N/A
			3		0				
			2		0				
			1		0				
0	1								

Table 8.2.1. CFP NVR-1 (Continued)

Hex Addr	Size	Access Type	Bit	Register Name Bit Filed Name	Value		Description	LSB Unit
					Value	Hex		
Base ID Information								
8011	1	RO		Transmitter Spectral Characteristics 2		04h	00000100	N/A
			7	Reserved	0		0: Reserved	N/A
			6		0		0: Reserved	N/A
			5		0		0: Reserved	N/A
			4	Number of Wavelengths per active Transmit Fiber	0		00100b: 4 Wavelengths	N/A
			3		0			
			2		1			
			1		0			
0		0						
8012	2	RO		Minimum Wavelength per Active Fiber		C5h 94h	C594h: 1264.5 nm	0.025 nm
8013								
8014	2	RO		Maximum Wavelength per Active Fiber		D0h FCh	D0FCh: 1337.5 nm	0.025 nm
8015								
8016	2	RO		Maximum per Lane Optical Width		32h C8h	32C8h: 13 nm	1 pm
8017								
8018	1	RO		Device Technology 1		20h	00100000	N/A
			7	Laser Source Technology	0		0010b: DFB	N/A
			6		0			N/A
			5		1			N/A
			4		0			N/A
			3	Transmitter modulation technology	0		0000b: DML	N/A
			2		0			N/A
			1		0			N/A
0	0		N/A					
8019	1	RO		Device Technology 2		08h	00001000	N/A
			7	Wavelength control	0		0: No wavelength control	N/A
			6	Cooled transmitter	0		0: Uncooled transmitter device	N/A
			5	Tunability	0		0: Transmitter NOT Tunable	N/A
			4	VOA implemented	0		0: Detector side VOA NOT implement	N/A
			3	Detector Type	1		10b: APD Detector	N/A
			2		0			
			1	CDR with EDC	0		0: CDR without EDC	N/A
0	Reserved	0		0: Reserved	N/A			
801A	1	RO		Signal Code		40h	01000000	N/A
			7	Modulation	0		01b: NRZ	N/A
			6		1			
			5	Signal coding	0		0000b: Non-PSK	N/A
			4		0			
			3		0			
			2		0			
			1	Reserved	0		0: Reserved	N/A
0	0		0: Reserved		N/A			
801B	1	RO		Maximum Total Optical Output Power per Connector		5Fh	5Fh: 9550 uW	100 uW
801C	1	RO		Maximum Optical Input Power per Network Lane		17h	17h: 2399 uW	100 uW
801D	1	RO		Maximum Power Consumption		28h	28h: 8 W	200 mW
801E	1	RO		Maximum Power Consumption in Low Power Mode		64h	64h: 2 W	20 mW
801F	1	RO		Maximum Operating Case Temp Range		46h	46h: 70 deg. C	1 degC
8020	1	RO		Minimum Operating Case Temp Range		FBh	FBh: -5 deg. C	1 degC

Table 8.2.1. CFP NVR-1 (Continued)

Hex Addr	Size	Access Type	Bit	Register Name Bit Filed Name	Value		Description	LSB Unit
					Value	Hex		
Base ID Information								
8021	16	RO		Vendor Name	S	53h	SumitomoElectric	ASCII
8022					u	75h		ASCII
8023					m	6Dh		ASCII
8024					i	69h		ASCII
8025					t	74h		ASCII
8026					o	6Fh		ASCII
8027					m	6Dh		ASCII
8028					o	6Fh		ASCII
8029					E	45h		ASCII
802A					l	6Ch		ASCII
802B					e	65h		ASCII
802C					c	63h		ASCII
802D					t	74h		ASCII
802E					r	72h		ASCII
802F					i	69h		ASCII
8030					c	63h		ASCII
8031	3	RO		Vendor OUI		00h	00005Fh	N/A
8034	16	RO		Vendor Part Number	S	53h	SCF0410E4CNGG01	ASCII
8035					C	43h		ASCII
8036					F	46h		ASCII
8037					0	30h		ASCII
8038					4	34h		ASCII
8039					l	31h		ASCII
803A					0	30h		ASCII
803B					E	45h		ASCII
803C					4	34h		ASCII
803D					C	43h		ASCII
803E					N	4Eh		ASCII
803F					G	47h		ASCII
8040					G	47h		ASCII
8041					0	30h		ASCII
8042					l	31h		ASCII
8043						20h		ASCII
8044	16	RO		Vendor Serial Number	\$	24h	Manufacturer serial number in ASCII code.	ASCII
8054	8	RO		Date Code	\$	24h	Date code in YYYYMMDD	ASCII
805C	2	RO		Lot Code	\$	24h	Lot code in ASCII code.	ASCII
805D				\$	24h			ASCII
805E	10	RO		CLEI Code		20h	' ' in ASCII code.	ASCII
805F						20h		ASCII
8060						20h		ASCII
8061						20h		ASCII
8062						20h		ASCII
8063						20h		ASCII
8064						20h		ASCII
8065						20h		ASCII
8066						20h		ASCII
8067						20h		ASCII
8068	1	RO	7-0	CFP MSA Hardware Specification Revision Number		0Eh	0Eh: Rev. 1.4	N/A
8069	1	RO	7-0	CFP MSA Management Interface Specification Revision Number		0Eh	0Eh: Rev. 1.4	N/A
806A	2	RO	7-0	Module Hardware Version Number		00h	Version: 0.2 (0.2: ES, 1.0 and higher: CS)	N/A
806B						02h		
806C	2	RO	7-0	Module Firmware Version Number		00h	Version: 0.2 (0.2: ES, 1.0 and higher: CS)	N/A
806D						02h		

Table 8.2.1. CFP NVR-1 (Continued)

Hex Addr	Size	Access Type	Bit	Register Name Bit Filed Name	Value		Description	LSB Unit
					Value	Hex		
Base ID Information								
806E	1	RO		Digital Diagnostic Monitoring Type		0Ch	00001100	N/A
			7	Reserved	0		0: Reserved	N/A
			6		0		0: Reserved	N/A
			5		0		0: Reserved	N/A
			4		0		0: Reserved	N/A
			3	Received power measurement type	1		1: Averaged Power	N/A
			2	Transmitted power measurement type	1		1: Averaged Power	N/A
			1	Reserved	0		0: Reserved	N/A
0	0		0: Reserved		N/A			
806F	1	RO		DDM Capability 1		03h	00000011	N/A
			7	Transceiver auxiliary monitor 2	0		00b: Not supported	N/A
			6		0		00b: Not supported	N/A
			5	Transceiver auxiliary monitor 1	0		00b: Not supported	N/A
			4		0		00b: Not supported	N/A
			3	Reserved	0		0: Reserved	N/A
			2	Transceiver SOA Ibias monitor	0		0: Not supported	N/A
			1	Transceiver Supply voltage monitor	1		1: Supported	N/A
			0	Transceiver temperature monitor	1		1: Supported	N/A
8070	1	RO		DDM Capability 2 (per Lane)		0Eh	00001110	N/A
			7	Reserved	0		0: Reserved	N/A
			6		0		0: Reserved	N/A
			5		0		0: Reserved	N/A
			4		0		0: Reserved	N/A
			3	Network Lane received power monitor	1		1: Supported	N/A
			2	Network Lane laser output power	1		1: Supported	N/A
			1	Network Lane laser bias current	1		1: Supported	N/A
			0	Network Lane laser temperature	0		0: Not supported	N/A
8071	1	RO		Module Enhanced Options		00h	00000000	N/A
			7	Host Lane Loop-back	0		0: Not supported	N/A
			6	Host Lane PRBS Supported	0		0: Not supported	N/A
			5	Host Lane emphasis control	0		0: Not supported	N/A
			4	Network Lane Loop-back	0		0: Not supported	N/A
			3	Network Lane PRBS	0		0: Not supported	N/A
			2	Decision Threshold Voltage control	0		0: Not supported	N/A
			1	Decision Phase control functions	0		0: Not supported	N/A
			0	Unidirectional TX/RX only Operation	0		0: Not supported	N/A
8072	1	RO		Maximum High-Power-up Time		02h	02h: 2 sec.	1 sec
8073	1	RO		Maximum TX-Turn-on Time		02h	02h: 2 sec.	1 sec
8074	1	RO		Host Lane Signal Spec		02h	02h: XLAUI	N/A
8075	1	RO		Heat Sink Type		00h	00000000	N/A
			7	Reserved	0		0: Reserved	N/A
			6		0		0: Reserved	N/A
			5		0		0: Reserved	N/A
			4		0		0: Reserved	N/A
			3		0		0: Reserved	N/A
			2		0		0: Reserved	N/A
			1		0		0: Reserved	N/A
			0	Heat Sink Type	0		0: Flat Top	N/A
8076	1	RO		Maximum TX-Turn-off Time		96h	96h: 150 ms	1ms
8077	1	RO		Maximum High-Power-down Time		01h	01h: 1 sec.	1sec

Table 8.2.1. CFP NVR-1 (Continued)

Hex Addr	Size	Access Type	Bit	Register Name Bit Filed Name	Value		Description	LSB Unit	
					Value	Hex			
Base ID Information									
8078	1	RO		Module Enhanced Options 2		00h	00000000		
			7	Reserved		0		0: Reserved	N/A
			6			0		0: Reserved	N/A
			5			0		0: Reserved	N/A
			4	Active Decision Voltage and Phase Function		0		0: Not supported	N/A
			3	RX FIFO Reset		0		0: Not supported	N/A
			2	RX FIFO Auto Reset		0		0: Not supported	N/A
			1	TX FIFO Reset		0		0: Not supported	N/A
0	TX FIFO Auto Reset		0		0: Not supported	N/A			
8079	1	RO		Transmitter Monitor Clock Options		00h	00000000		
			7	1/16 of Host Lane Rate		0		0: Not supported	N/A
			6	1/16 of Network Lane Rate		0		0: Not supported	N/A
			5	1/64 of Host Lane Rate		0		0: Not supported	N/A
			4	1/64 of Network Lane Rate		0		0: Not supported	N/A
			3	Reserved		0		0: Reserved	N/A
			2	1/8 of Network Lane Rate		0		0: Not supported	N/A
			1	Reserved		0		0: Reserved	N/A
0	Monitor Clock Option		0		0: Not supported	N/A			
807A	1	RO		Receiver Monitor Clock Options		00h	00000000		
			7	1/16 of Host Lane Rate		0		0: Not supported	N/A
			6	1/16 of Network Lane Rate		0		0: Not supported	N/A
			5	1/64 of Host Lane Rate		0		0: Not supported	N/A
			4	1/64 of Network Lane Rate		0		0: Not supported	N/A
			3	Reserved		0		0: Reserved	N/A
			2	1/8 of Network Lane Rate		0		0: Not supported	N/A
			1	Reserved		0		0: Reserved	N/A
0	Monitor Clock Option		0		0: Not supported	N/A			
807B	1	RO		Reserved		00h	0: Reserved	N/A	
807C	1	RO		Reserved		00h	0: Reserved	N/A	
807D	1	RO		Reserved		00h	0: Reserved	N/A	
807E	1	RO		Reserved		00h	0: Reserved	N/A	
807F	1	RO		CFP NVR 1 Checksum	\$	24h	The 8-bit unsigned sum of all CFP NVR 1 contents from address 8000h through 807Eh inclusive.	N/A	

Table 8.2.2. CFP NVR-2

Hex Addr	Size	Access Type	Bit	Register Name Bit Filed Name	Value		Description	LSB Unit
					Value	Hex		
Alarm/Warning Threshold Registers								
8080	2	RO		Transceiver Temp High Alarm	50h	5000h: 80 degC	1/256 degC	
8081				Threshold	00h			
8082	2	RO		Transceiver Temp High Warning	4Bh	4B00h: 75 degC		
8083				Threshold	00h			
8084	2	RO		Transceiver Temp Low Warning	F6h	F600h: -10 degC		
8085				Threshold	00h			
8086	2	RO		Transceiver Temp Low Alarm	F1h	F100h: -15 degC		
8087				Threshold	00h			
8088	2	RO		VCC High Alarm Threshold	94h	943Eh: 3.795V	0.1 mV	
8089				Threshold	3Eh			
808A	2	RO		VCC High Warning Threshold	8Dh	8DCCh: 3.63V		
808B				Threshold	CCh			
808C	2	RO		VCC Low Warning Threshold	74h	7404h: 2.97V		
808D				Threshold	04h			
808E	2	RO		VCC Low Alarm Threshold	6Dh	6D92h: 2.805V		
808F				Threshold	92h			
80A8	2	RO		Laser Bias Current High Alarm	C3h	C350h: 100 mA	2uA	
80A9				Threshold	50h			
80AA	2	RO		Laser Bias Current High Warning	9Ch	9C40h: 80 mA		
80AB				Threshold	40h			
80AC	2	RO		Laser Bias Current Low Warning	09h	9C4h: 5 mA		
80AD				Threshold	C4h			
80AE	2	RO		Laser Bias Current Low Alarm	00h	0h: 0 mA		
80AF				Threshold	00h			
80B0	2	RO		Laser Output Power High Alarm	BAh	BAF7h: 6.8 dBm	0.1 uW	
80B1				Threshold	F7h			
80B2	2	RO		Laser Output Power High Warning	75h	75F7h: 4.8 dBm		
80B3				Threshold	F7h			
80B4	2	RO		Laser Output Power Low Warning	18h	1815h: -2.1 dBm		
80B5				Threshold	15h			
80B6	2	RO		Laser Output Power Low Alarm	0Fh	0F32h: -4.1 dBm		
80B7				Threshold	32h			
80C0	2	RO		Receive Optical Power High Alarm	39h	39C7h: 1.7 dBm	0.1 uW	
80C1				Threshold	C7h			
80C2	2	RO		Receive Optical Power High Warning	24h	2474h: -0.3 dBm		
80C3				Threshold	74h			
80C4	2	RO		Receive Optical Power Low Warning	00h	003Fh: -22 dBm		
80C5				Threshold	3Fh			
80C6	2	RO		Receive Optical Power Low Alarm	00h	0027h: -24 dBm		
80C7				Threshold	27h			
80C8	55	RO		Reserved	00h	0000h: Reserved	N/A	
80FF	1	RO		CFP NVR 2 Checksum	\$	24h	The 8-bit unsigned sum of all CFP NVR 2 contents from address 8080h through 80FEh inclusive.	N/A

Table 8.2.3. CFP NVR-3

Hex Addr	Size	Access Type	Bit	Register Name Bit Filed Name	Value		Description	LSB Unit
					Value	Hex		
Network Lane BOL Measurements								
8100	2	RO		RX Sensitivity for network lanes 0		F7h	F7CCh: -21 dBm	0.01 dBm
8101						CCh		
8102	2	RO		RX Sensitivity for network lanes 1		F7h	F7CCh: -21 dBm	
8103						CCh		
8104	2	RO		RX Sensitivity for network lanes 2		F7h	F7CCh: -21 dBm	
8105						CCh		
8106	2	RO		RX Sensitivity for network lanes 3		F7h	F7CCh: -21 dBm	
8107						CCh		
8120	2	RO		TX Power Spec for network lanes 0		00h	0064h: 1 dBm	0.01 dBm
8121						64h		
8122	2	RO		TX Power Spec for network lanes 1		00h	0064h: 1 dBm	
8123						64h		
8124	2	RO		TX Power Spec for network lanes 2		00h	0064h: 1 dBm	
8125						64h		
8126	2	RO		TX Power Spec for network lanes 3		00h	0064h: 1 dBm	
8127						64h		
8140	2	RO		Measured ER for network lanes 0		02h	02BCh: 7 dB	0.01 dB
8141						BCh		
8142	2	RO		Measured ER for network lanes 1		02h	02BCh: 7 dB	
8143						BCh		
8144	2	RO		Measured ER for network lanes 2		02h	02BCh: 7 dB	
8145						BCh		
8146	2	RO		Measured ER for network lanes 3		02h	02BCh: 7 dB	
8147						BCh		
8160	2	RO		Path Penalty for network lanes 0		00h	0064h: 1 dB	0.01 dB
8161						64h		
8162	2	RO		Path Penalty for network lanes 1		00h	0064h: 1 dB	
8163						64h		
8164	2	RO		Path Penalty for network lanes 2		00h	0064h: 1 dB	
8165						64h		
8166	2	RO		Path Penalty for network lanes 3		00h	0064h: 1 dB	
8167						64h		

Comment: It doesn't measure Path Penalty for guaranteed design.

Table 8.2.4. CFP NVR-4

Hex Addr	Size	Access Type	Bit	Register Name Bit Filed Name	Value		Description	LSB Unit
					Value	Hex		
User data registers.								
8180	1	RO	7~0	CFP NVR 3 Checksum	\$	24h	The 8-bit unsigned sum of all CFP NVR 3 contents from address 8100h through 817Fh inclusive.	N/A
8181	127	RO	7~1	Reserved		00h	00h: Reserved	N/A

8.3 Registers for Digital Diagnostic Monitors (DDM)

Table 8.3.1. Network Lane VR2 A/D value measurement Registers DDM

CFP Module VR1						
Hex Addr.	Size	Access Type	Bit	Register Name Bit Field Name	Description	Init Value
Module Analog A/D Value Registers						
A02F	1	RO	15~0	Module Temp Monitor A/D Value	Internally measured temperature in degrees Celsius, a 16-bit signed integer with LSB = 1/256 of a degree Celsius, representing a total range from -128 to + 127 255/256 degC. MSA valid range is between -40 and +125C. Accuracy shall be better than +/- 3 degC over the whole temperature range.	0000h
A030	1	RO	15~0	Module Power supply 3.3 V Monitor A/D Value	Internally measured transceiver supply voltage, a 16-bit unsigned integer with LSB = 0.1 mV, yielding a total measurement range of 0 to 6.5535 Volts. Accuracy shall be better than +/-3% of the nominal value over specified operating temperature and voltage range.	0000h

Table 8.3.2. Network Lane VR2 A/D value measurement Registers

Network Lane VR 2						
Hex Addr.	Size	Access Type	Bit	Register Name Bit Field Name	Description	Init Value
Network Lane A/D value Measurement Registers						
A2A0	16	RO	15~0	Network Lane n Laser Bias Current monitor A/D value	16 registers, one for each network lane, represent 16 network lanes. n = 0, 1, ..., N-1. N_max = 16. Actual N is module dependent. Measured laser bias current in uA, a 16-bit unsigned integer with LSB = 2 uA, representing a total measurement range of 0 to 131.072 mA. Minimum accuracy shall be +/- 10% of the nominal value over temperature and voltage.	0000h
A2B0	16	RO	15~0	Network Lane n Laser Output Power monitor A/D value	16 registers, one for each network lane, represent 16 network lanes. n = 0, 1, ..., N-1. N_max = 16. Actual N is module dependent. Measured TX output power in uW, a 16-bit unsigned integer with LSB = 0.1 uW, representing a range of laser output power from 0 to 6.5535 mW (-40 to +8.2 dBm). Accuracy must be better than +/- 2 dB over temperature and voltage range. Relative accuracy must be better than 1 dB.	0000h
A2D0	16	RO	15~0	Network Lane n Receiver Input Power monitor A/D value	16 registers, one for each network lane, represent 16 network lanes. n = 0, 1, ..., N-1. N_max = 16. Actual N is module dependent. Measured received input power in uW, a 16-bit unsigned integer with LSB = 0.1 uW, representing a power range from 0 to 6.5535 mW (-40 to +8.2 dBm). Value can represent either average received power or OMA depending upon how bit 3 of Register 8080h is set. Accuracy must be better than +/- 2dB over temperature and voltage. This accuracy shall be maintained for input power levels up to the lesser of maximum transmitted or maximum received optical power per the appropriate standard. It shall be maintained down to the minimum transmitted power minus cable plant loss per the appropriate standard. Relative accuracy shall be better than 1 dB over the received power range, temperature range, voltage range, and the life of the product.	0000h

9. Qualification Testing

The SCF0400E4 series 40Gb/s transceivers are qualified to Sumitomo Electric Industries internal design and manufacturing standards. Telecordia GR-468-CORE reliability test standards, using methods per MIL-STD-883 for mechanical integrity, endurance, moisture, flammability and ESD thresholds, are followed.

10 RoHS COMPLIANCY

Compliance versus requirements contained inside the following reference document is guaranteed: "Directive 2002/95/EC of 27 January 2003 on the restriction of the use of certain hazardous substances in electrical and electronic equipment" from official journal of European Union (European Parliament and of the Council). This product is Compliant at RoHS-6/6 level and contains no leaded solders.

11. Laser Safety Information

The SCF0400E4 series transceivers use a semiconductor laser that is classified as Class 1 laser products per the laser safety requirements of FDA/CDRH, 21 CFR1040.10 and 1040.11. These products have also been tested and certified as Class 1 laser products per IEC60825-1:2007 and IEC60825-1:2001 International standards.

Caution

If this product is used under conditions not recommended in the specification or is used with unauthorized revision, the classification for laser product safety is invalid. Reclassify the product at your responsibility and take appropriate safety measures.

12. Electromagnetic Compatibility

EMI (Emission)

The SCF0400E4 series 40Gb/s transceivers are designed to meet FCC Class B limits for emissions and noise immunity per CENELEC EN50 081 and 082 specifications.

RF Immunity

The SCF0400E4 has an immunity to operate when tested in accordance with IEC 61000-4-3 (80- 1000MHz, Test Level 3) and GR-1089.

Electrostatic Discharge (ESD) Immunity

The SCF0400E4 has an immunity against direct and indirect ESD when tested accordance with IEC 61000-4-2.

13. Ordering Information

Part Numbering System

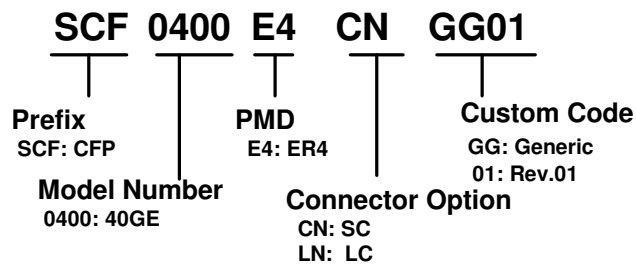

Evaluation Board Kit

For test purposes the evaluation board model number SK0400A may be ordered to use with the SCF0400L4 series transceivers.

SK0400A : SCF0400/0410 CFP evaluation board

Ordering Number

Table 14. SCF0400L4 Series Part Number Information

MPN	Optical I/F		Operating Lane Data Rate				
	40GE-ER4	C4S1-2D1	9.95328Gb/s	10.3125Gb/s	10.75460Gb/s	11.14274Gb/s	11.14584Gb/s
SC and Flat Top							
SCF0400E4CN01	V			V			
SCF0420E4CN01	V	V		V	V		
LC and Flat Top							
SCF0400E4LN01	V			V			
SCF0420E4LN01	V	V		V	V		

Contact Information

U.S.A.

Sumitomo Electric Device Innovations, U.S.A., Inc.

<West Coast (USA Headquarters)>

2355 Zanker Rd. San Jose, CA 95131-1138, USA

Tel: +1-408-232-9500

Fax: +1-408-428-9111

<East Coast>

4021 Stirrup Creek Drive, Suite 200, Durham, NC 27703, USA

Tel: +1-919-361-1600

Fax: +1-919-361-1619

Email: information@sei-device.com

<http://www.sei-device.com/>

Europe

Sumitomo Electric Europe Ltd.

220 Centennial Park, Elstree, Herts, WD6 3SL UK

Tel: +44-208-953-8681

Fax: +44-208-207-5950

E-mail: photonics@sumielectric.com

<http://www.sumielectric.com>

Asia

Sumitomo Electrics Asia Ltd.

Photonics Department

Room 2624 - 2637, 26F., Sun Hung Kai Center, 30 Harbour Road, Wanchai, Hongkong.

Tel: +852-2576-0080

Fax: +852-2576-6412

Japan

Sumitomo Electric Industries, Ltd.

Device Sales Department

<Tokyo>

3-9-1, Shibaura, Minato-ku, Tokyo 108-8539, Japan

TEL +81-3-6722-3286

FAX +81-3-6722-3284

<Osaka>

4-5-33, Kitahama, Chuo-ku, Osaka 541-0041, Japan

Tel: +81-6-6220-4245

Fax: +81-6-6222-6231

E-mail: optoele-sales-pro-sml@list.sei.jp

<http://www.sei.co.jp/products/index.html>