

FLK027XP, FLK027XV

GaAs FET & HEMT Chips

FEATURES

- High Output Power: $P_{1dB} = 24.0dBm(Typ.)$
- High Gain: $G_{1dB} = 7.0dB(Typ.)$
- High PAE: $\eta_{add} = 32\%(Typ.)$
- Proven Reliability

DESCRIPTION

The FLK027XP, and FLK027XV chip is a power GaAs FET that is designed for general purpose applications in the Ku-Band frequency range as it provides superior power, gain, and efficiency.

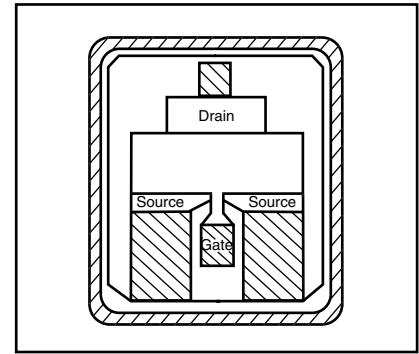

Eudyna stringent Quality Assurance Program assures the highest reliability and consistent performance.

ABSOLUTE MAXIMUM RATING (Ambient Temperature $T_a=25^\circ C$)

Item	Symbol	Condition	Rating	Unit
Drain-Source Voltage	V_{DS}		15	V
Gate-Source Voltage	V_{GS}		-5	V
Total Power Dissipation	P_{tot}	$T_c = 25^\circ C$	1.88	W
Storage Temperature	T_{stg}		-65 to +175	$^\circ C$
Channel Temperature	T_{ch}		175	$^\circ C$

Eudyna recommends the following conditions for the reliable operation of GaAs FETs:

1. The drain-source operating voltage (V_{DS}) should not exceed 10 volts.
2. The forward and reverse gate currents should not exceed 2.2 and -0.1 mA respectively with gate resistance of 2000 Ω .
3. The operating channel temperature (T_{ch}) should not exceed 145 $^\circ C$.

ELECTRICAL CHARACTERISTICS (Ambient Temperature $T_a=25^\circ C$)

Item	Symbol	Test Conditions	Limit			Unit
			Min.	Typ.	Max.	
Saturated Drain Current	I_{DSS}	$V_{DS} = 5V, V_{GS} = 0V$	-	100	150	mA
Transconductance	g_m	$V_{DS} = 5V, I_{DS} = 65mA$	-	50	-	mS
Pinch-off Voltage	V_p	$V_{DS} = 5V, I_{DS} = 5mA$	-1.0	-2.0	-3.5	V
Gate Source Breakdown Voltage	V_{GSO}	$I_{GS} = -5\mu A$	-5	-	-	V
Output Power at 1dB Gain Compression Point	P_{1dB}	$V_{DS} = 10V$ $I_{DS} \approx 0.6I_{DSS}$ $f = 14.5GHz$	23	24	-	dBm
Power Gain at 1dB Gain Compression Point	G_{1dB}		6	7	-	dB
Power-added Efficiency	η_{add}		-	32	-	%
Thermal Resistance	R_{th}	Channel to Case	-	40	80	$^\circ C/W$

Note: RF parameter sample size 10pcs. criteria (accept/reject)=(2/3)

The chip must be enclosed in a hermetically sealed environment for optimum performance and reliability.

Eudyna

FLK027XP, FLK027XV

GaAs FET & HEMT Chips

POWER DERATING CURVE

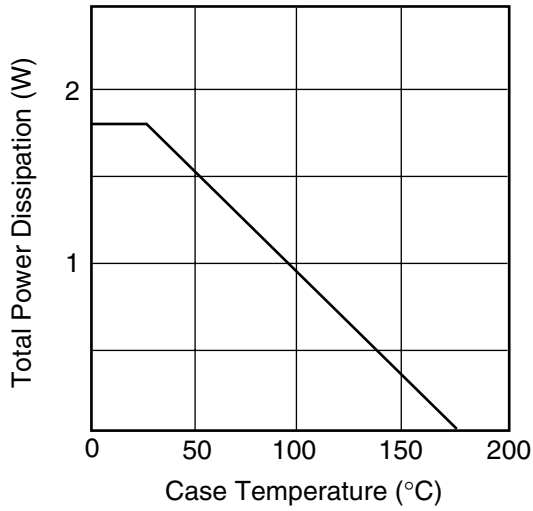

DRAIN CURRENT vs. DRAIN-SOURCE VOLTAGE

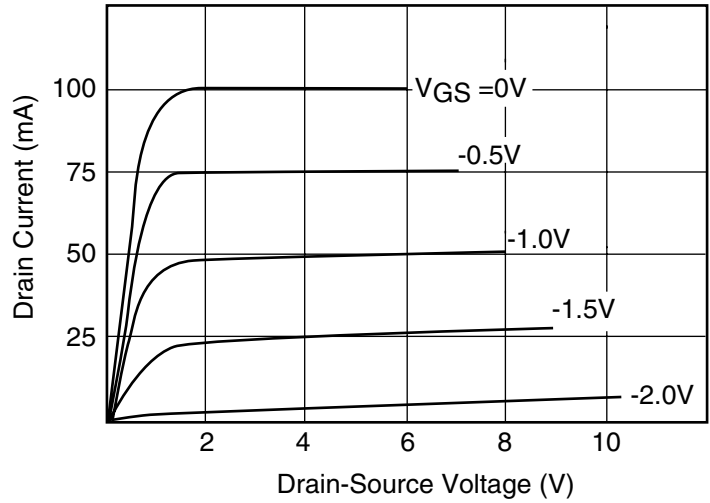

OUTPUT POWER vs. INPUT POWER

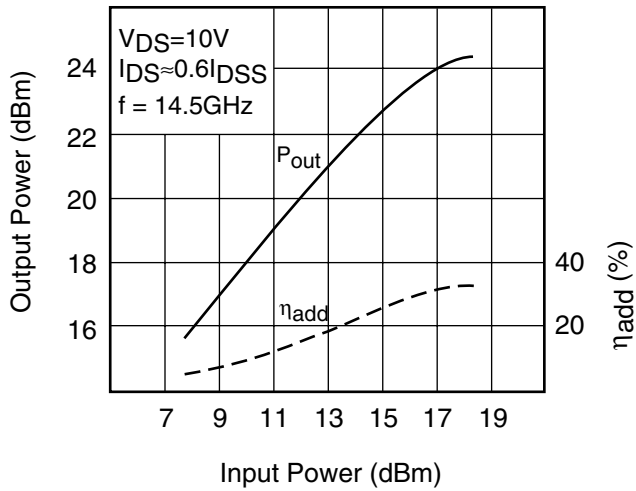

P_{1dB} & η_{add} vs. V_{DS}

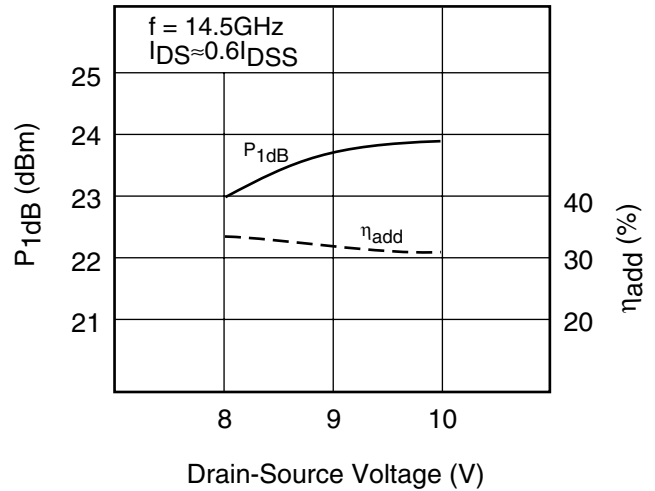

FLK027XP, FLK027XV

GaAs FET & HEMT Chips

S-PARAMETERS

$V_{DS} = 10V, I_{DS} = 60mA$

FLK027XP

FLK027XV

FREQUENCY (MHZ)	S11		S21		S12		S22	
	MAG	ANG	MAG	ANG	MAG	ANG	MAG	ANG
100	1.000	-3.3	4.479	177.6	.003	88.1	.735	-1.1
500	.996	-16.4	4.436	168.1	.013	80.7	.732	-5.4
1000	.984	-32.4	4.309	156.4	.025	71.7	.721	-10.6
1500	.967	-47.6	4.121	145.3	.035	63.2	.705	-15.4
2000	.947	-61.7	3.894	135.0	.044	55.5	.687	-19.8
2500	.926	-74.7	3.651	125.3	.052	48.5	.668	-23.7
3000	.907	-86.5	3.407	116.4	.058	42.2	.649	-27.3
3500	.890	-97.2	3.174	108.2	.063	36.6	.633	-30.6
4000	.874	-107.0	2.956	100.5	.067	31.6	.618	-33.7
4500	.861	-115.8	2.756	93.4	.070	27.	.605	-36.6
5000	.850	-123.9	2.573	86.7	.072	22.9	.594	-39.4
5500	.841	-131.3	2.409	80.4	.074	19.2	.585	-42.1
6000	.834	-138.0	2.259	74.4	.076	15.8	.578	-44.8
6500	.828	-144.3	2.125	68.6	.077	12.6	.571	-47.5
7000	.823	-150.1	2.003	63.1	.078	9.6	.566	-50.2
7500	.820	-155.5	1.892	57.8	.079	6.9	.562	-52.9
8000	.817	-160.6	1.792	52.6	.080	4.3	.559	-55.7
8500	.815	-165.4	1.700	47.6	.080	1.8	.556	-58.4
9000	.813	-169.8	1.616	42.8	.080	-0.5	.555	-61.2
9500	.812	-174.1	1.538	38.0	.080	-2.8	.553	-64.1
10000	.812	-178.1	1.467	33.4	.081	-4.9	.553	-66.9
10500	.812	-178.1	1.401	28.8	.081	-6.9	.553	-69.9
11000	.812	-174.4	1.340	24.3	.080	-8.9	.553	-72.8
11500	.813	-171.0	1.283	19.9	.080	-10.9	.554	-75.8
12000	.814	-167.6	1.230	15.6	.080	-12.7	.555	-78.8
12500	.815	-164.4	1.181	11.3	.080	-14.5	.557	-81.9
13000	.816	-161.3	1.134	7.1	.080	-16.3	.559	-85.0
13500	.818	-158.4	1.090	3.0	.079	-18.0	.562	-88.1
14000	.819	-155.5	1.048	-1.1	.079	-19.7	.565	-91.3
14500	.821	-152.8	1.009	-5.2	.078	-21.3	.568	-94.4
15000	.823	-150.1	0.971	-9.2	.078	-23.0	.571	-97.6
15500	.825	-147.6	0.936	-13.1	.078	-24.5	.575	-100.8
16000	.827	-145.1	0.902	-17.1	.077	-26.1	.580	-104.1
16500	.829	-142.7	0.869	-21.0	.076	-27.6	.584	-107.3
17000	.831	-140.4	0.838	-24.8	.076	-29.1	.589	-110.6
17500	.834	-138.1	0.808	-28.6	.075	-30.6	.594	-113.9
18000	.836	-135.9	0.780	-32.4	.075	-32.0	.600	-117.1
18500	.838	-133.8	0.752	-36.2	.074	-33.5	.606	-120.4
19000	.841	-131.7	0.725	-39.9	.073	-34.9	.612	-123.7
19500	.843	-129.7	0.700	-43.6	.073	-36.2	.618	-127.0
20000	.846	-127.8	0.675	-47.2	.072	-37.6	.625	-130.2

NOTE:* The data includes bonding wires.

n: number of wires

Gate n=1 (0.2mm length, 25µm Dia Au wire)

Drain n=1 (0.2mm length, 25µm Dia Au wire)

Source n=4 (0.3mm length, 25µm Dia Au wire)

FREQUENCY (MHZ)	S11		S21		S12		S22	
	MAG	ANG	MAG	ANG	MAG	ANG	MAG	ANG
100	1.000	-3.3	4.479	177.6	.003	88.1	.735	-1.1
500	.996	-16.4	4.436	168.1	.013	80.7	.732	-5.4
1000	.984	-32.4	4.310	156.5	.025	71.6	.721	-10.6
1500	.968	-47.6	4.122	145.4	.035	63.1	.705	-15.4
2000	.948	-61.7	3.896	135.0	.044	55.4	.687	-19.8
2500	.928	-74.7	3.653	125.4	.052	48.3	.668	-23.8
3000	.909	-86.5	3.410	116.5	.058	42.0	.649	-27.4
3500	.892	-97.2	3.177	108.3	.063	36.3	.633	-30.7
4000	.877	-107.0	2.959	100.6	.067	31.2	.618	-33.8
4500	.864	-115.8	2.759	93.5	.070	26.6	.605	-36.7
5000	.854	-123.9	2.576	86.8	.073	22.5	.594	-39.5
5500	.845	-131.2	2.411	80.4	.075	18.7	.585	-42.2
6000	.837	-138.0	2.262	74.4	.077	15.2	.577	-44.9
6500	.831	-144.3	2.127	68.7	.078	11.9	.571	-47.6
7000	.827	-150.1	2.005	63.1	.079	8.9	.566	-50.3
7500	.823	-155.5	1.894	57.8	.080	6.0	.562	-53.0
8000	.820	-160.5	1.793	52.7	.081	3.3	.558	-55.8
8500	.818	-165.3	1.701	47.7	.081	0.8	.556	-58.5
9000	.816	-169.7	1.617	42.8	.082	-1.6	.554	-61.3
9500	.815	-174.0	1.539	38.0	.082	-4.0	.553	-64.1
10000	.814	-178.0	1.468	33.4	.082	-6.2	.552	-67.0
10500	.814	-178.2	1.402	28.8	.082	-8.4	.552	-69.9
11000	.814	-174.6	1.341	24.3	.083	-10.5	.553	-72.8
11500	.814	-171.1	1.284	19.9	.083	-12.5	.553	-75.8
12000	.815	-167.8	1.231	15.6	.083	-14.5	.555	-78.8
12500	.816	-164.6	1.181	11.3	.082	-16.4	.556	-81.8
13000	.817	-161.5	1.135	7.1	.082	-18.3	.558	-84.9
13500	.818	-158.6	1.091	3.0	.082	-20.2	.561	-88.0
14000	.820	-155.8	1.049	-1.1	.082	-22.0	.564	-91.1
14500	.821	-153.0	1.010	-5.2	.082	-23.8	.567	-94.3
15000	.823	-150.4	.973	-9.2	.081	-25.6	.570	-97.4
15500	.825	-147.8	.937	-13.2	.081	-27.4	.574	-100.6
16000	.827	-145.4	.904	-17.1	.081	-29.1	.578	-103.8
16500	.829	-143.0	.872	-21.0	.080	-30.8	.583	-107.0
17000	.831	-140.7	.841	-24.9	.080	-32.5	.588	-110.3
17500	.833	-138.4	.811	-28.7	.079	-34.2	.593	-113.5
18000	.835	-136.2	.783	-32.5	.079	-35.8	.598	-116.7
18500	.837	-134.1	.756	-36.2	.078	-37.5	.604	-120.0
19000	.839	-132.1	.729	-39.9	.078	-39.1	.610	-123.2
19500	.842	-130.1	.704	-43.6	.077	-40.7	.616	-126.4
20000	.844	-128.1	.680	-47.3	.077	-42.3	.623	-129.6

NOTE:* The data includes bonding wires.

n: number of wires

Gate n=1 (0.2mm length, 25µm Dia Au wire)

Drain n=1 (0.2mm length, 25µm Dia Au wire)

FLK027XP, FLK027XV

GaAs FET & HEMT Chips

CHIP OUTLINE

