

FLK207MH-14

X, Ku Band Power GaAs FET

FEATURES

- High Output Power: $P_{1dB} = 32.5dBm(Typ.)$
- High Gain: $G_{1dB} = 6.0dB(Typ.)$
- High PAE: $\eta_{add} = 27%(Typ.)$
- Proven Reliability
- Hermetic Metal/Ceramic Package

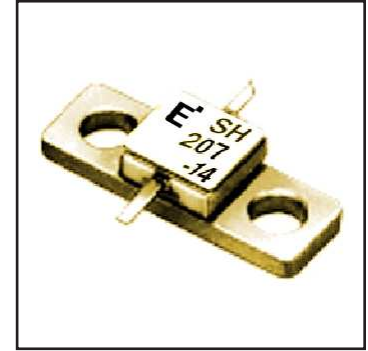

DESCRIPTION

The FLK207MH-14 is a power GaAs FET that is designed for general purpose applications in the Ku-Band frequency range as it provides superior power, gain, and efficiency.

Eudyna stringent Quality Assurance Program assures the highest reliability and consistent performance.

ABSOLUTE MAXIMUM RATING (Ambient Temperature $T_a=25^\circ C$)

Item	Symbol	Condition	Rating	Unit
Drain-Source Voltage	V_{DS}		15	V
Gate-Source Voltage	V_{GS}		-5	V
Total Power Dissipation	P_T	$T_c = 25^\circ C$	12.5	W
Storage Temperature	T_{stg}		-65 to +175	$^\circ C$
Channel Temperature	T_{ch}		175	$^\circ C$

Eudyna recommends the following conditions for the reliable operation of GaAs FETs:

1. The drain-source operating voltage (V_{DS}) should not exceed 10 volts.
2. The forward and reverse gate currents should not exceed 17.8 and -1.0 mA respectively with gate resistance of 250 Ω .
3. The operating channel temperature (T_{ch}) should not exceed 145 $^\circ C$.

ELECTRICAL CHARACTERISTICS (Ambient Temperature $T_a=25^\circ C$)

Item	Symbol	Test Conditions	Limit			Unit
			Min.	Typ.	Max.	
Saturated Drain Current	I_{DSS}	$V_{DS} = 5V, V_{GS} = 0V$	-	800	1200	mA
Transconductance	g_m	$V_{DS} = 5V, I_{DS} = 500mA$	-	400	-	mS
Pinch-off Voltage	V_p	$V_{DS} = 5V, I_{DS} = 40mA$	-1.0	-2.0	-3.5	V
Gate Source Breakdown Voltage	V_{GSO}	$I_{GS} = -40\mu A$	-5	-	-	V
Output Power at 1dB G.C.P.	P_{1dB}	$V_{DS} = 10V,$ $I_{DS} = 0.6 I_{DSS} (Typ.),$ $f = 14.5 GHz$	31.5	32.5	-	dBm
Power Gain at 1dB G.C.P.	G_{1dB}		5.0	6.0	-	dB
Power-added Efficiency	η_{add}		-	27	-	%
Thermal Resistance	R_{th}	Channel to Case	-	10	12	$^\circ C/W$

CASE STYLE: MH

G.C.P.: Gain Compression Point

FLK207MH-14

X, Ku Band Power GaAs FET

POWER DERATING CURVE

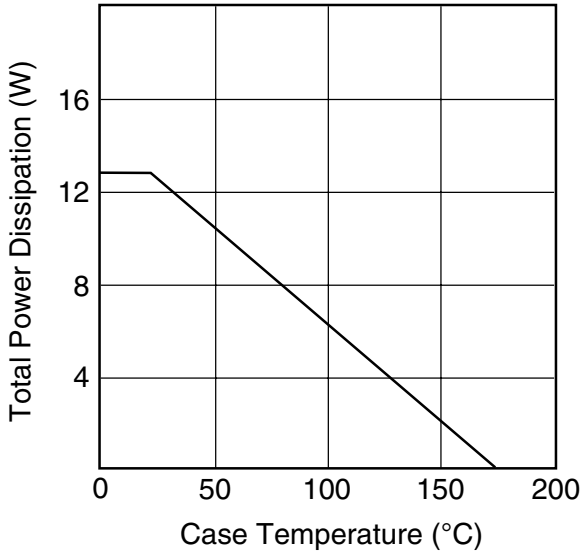

DRAIN CURRENT vs. DRAIN-SOURCE VOLTAGE

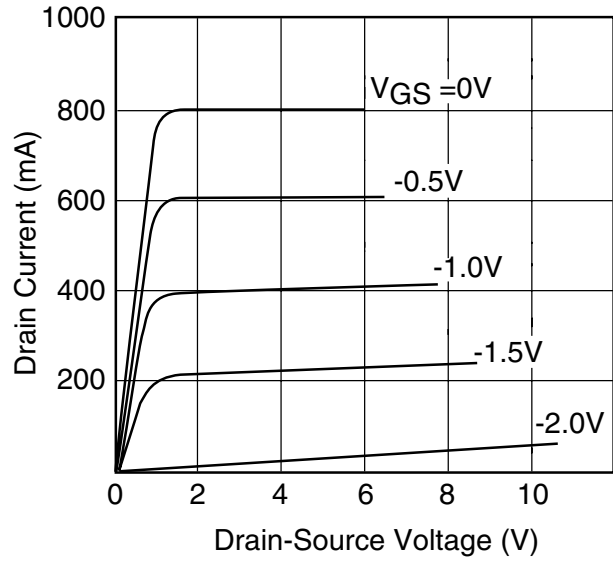

OUTPUT POWER vs. INPUT POWER

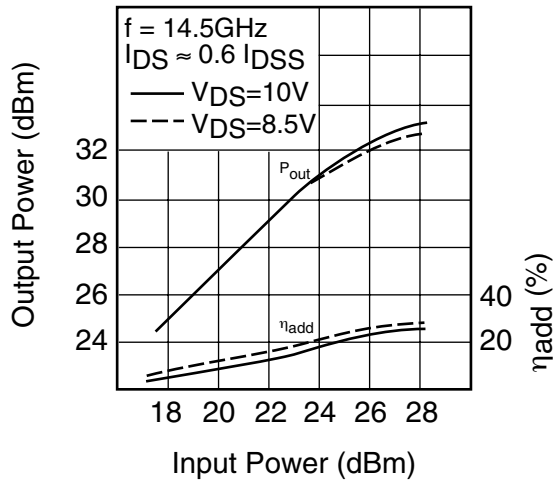

P_{1dB} & η_{add} vs. V_{DS}

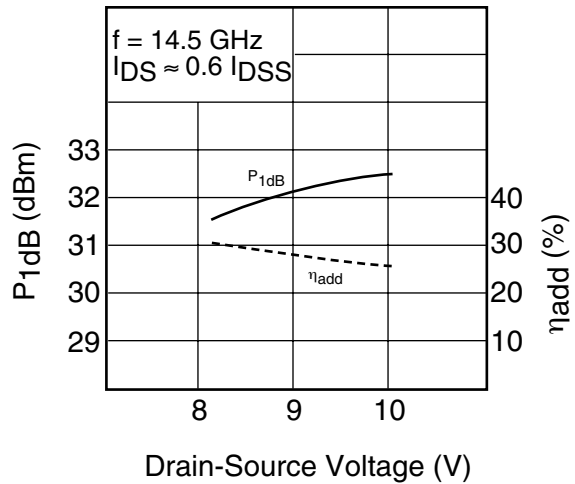

FLK207MH-14

X, Ku Band Power GaAs FET

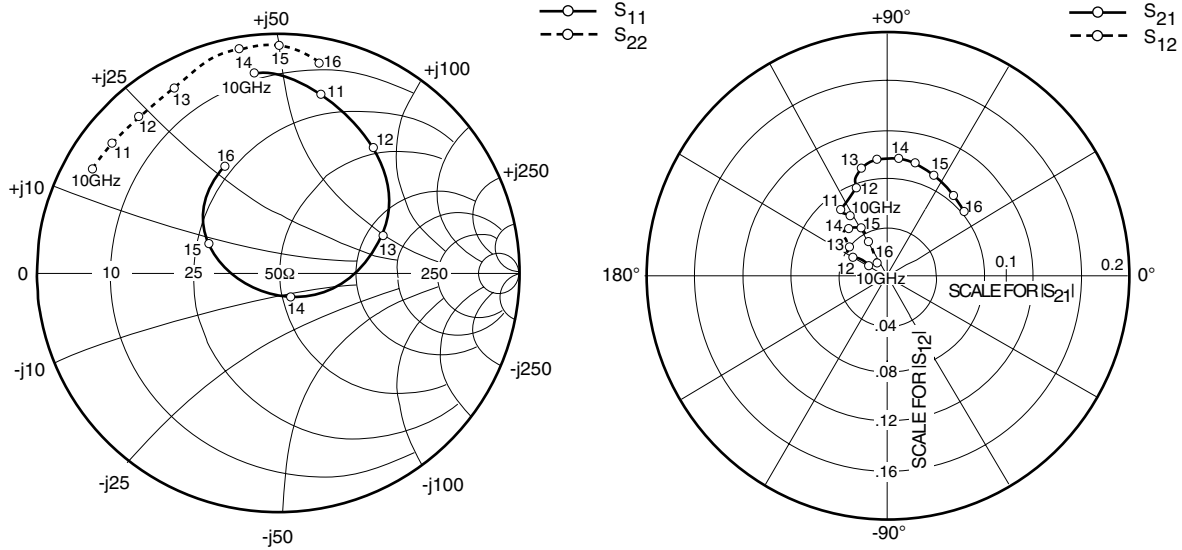

S-PARAMETERS

$V_{DS} = 10V, I_{DS} = 480mA$

FREQUENCY (MHZ)	S11		S21		S12		S22	
	MAG	ANG	MAG	ANG	MAG	ANG	MAG	ANG
500	.951	-135.0	7.948	115.3	.023	32.8	.291	-139.9
1000	.938	-159.2	4.366	104.8	.024	29.8	.348	-143.6
10000	.846	96.5	.594	123.2	.018	154.8	.889	151.1
10500	.813	86.6	.623	126.4	.023	149.7	.896	147.0
11000	.772	77.0	.674	125.9	.024	146.4	.880	142.6
11500	.721	65.2	.701	119.2	.027	148.3	.875	137.4
12000	.657	53.6	.781	110.3	.030	152.1	.884	132.1
12500	.565	38.8	.842	109.1	.039	148.5	.875	125.8
13000	.458	20.2	.905	105.1	.040	143.5	.885	119.5
13500	.263	-9.4	.955	95.5	.048	139.4	.921	113.1
14000	.109	-59.8	.969	85.3	.050	130.7	.949	100.2
14500	.166	-168.0	.948	76.9	.047	127.3	.950	95.0
15000	.314	156.4	.913	65.9	.045	119.9	.953	90.5
15500	.436	134.4	.843	50.5	.033	120.6	.928	86.0
16000	.503	116.8	.812	39.8	.014	129.2	.889	79.7

FLK207MH-14

X, Ku Band Power GaAs FET

Case Style "MH" Metal-Ceramic Hermetic Package

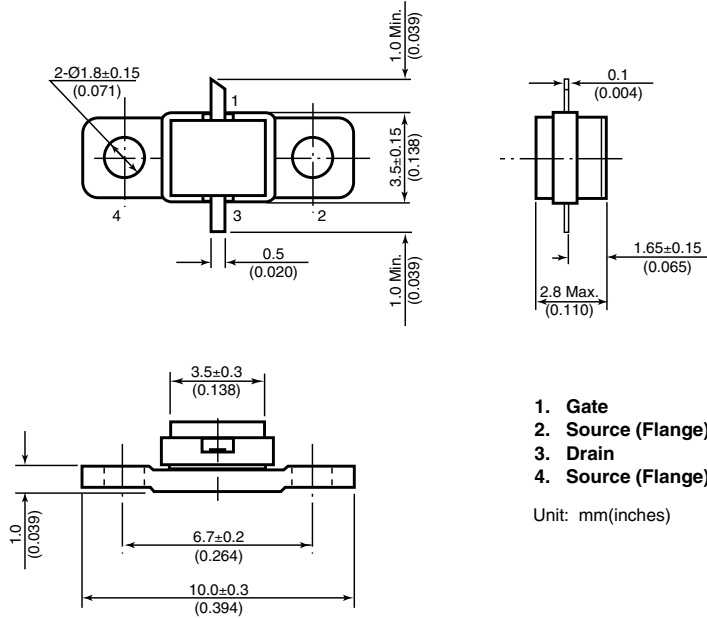

1. Gate
2. Source (Flange)
3. Drain
4. Source (Flange)

Unit: mm(inches)