

FLC257MH-8

C-Band Power GaAs FET

FEATURES

- High Output Power: $P_{1dB} = 34.0\text{dBm(Typ.)}$
- High Gain: $G_{1dB} = 8.0\text{dB(Typ.)}$
- High PAE: $\eta_{add} = 35\%\text{(Typ.)}$
- Proven Reliability
- Hermetic Metal/Ceramic Package

DESCRIPTION

The FLC257MH-8 is a power GaAs FET that is designed for general purpose applications in the C-Band frequency range as it provides superior power, gain, and efficiency.

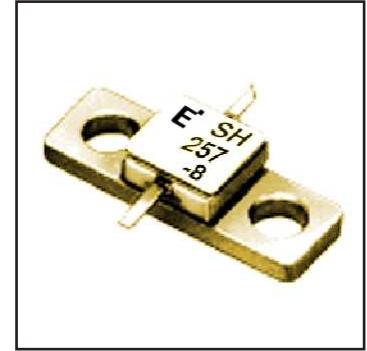

Eudyna stringent Quality Assurance Program assures the highest reliability and consistent performance.

ABSOLUTE MAXIMUM RATING (Ambient Temperature $T_a=25^\circ\text{C}$)

Item	Symbol	Condition	Rating	Unit
Drain-Source Voltage	V_{DS}		15	V
Gate-Source Voltage	V_{GS}		-5	V
Total Power Dissipation	P_T	$T_C = 25^\circ\text{C}$	15	W
Storage Temperature	T_{stg}		-65 to +175	$^\circ\text{C}$
Channel Temperature	T_{ch}		175	$^\circ\text{C}$

Eudyna recommends the following conditions for the reliable operation of GaAs FETs:

1. The drain-source operating voltage (V_{DS}) should not exceed 10 volts.
2. The forward and reverse gate currents should not exceed 17.8 and -1.2 mA respectively with gate resistance of 200Ω .
3. The operating channel temperature (T_{ch}) should not exceed 145°C .

ELECTRICAL CHARACTERISTICS (Ambient Temperature $T_a=25^\circ\text{C}$)

Item	Symbol	Test Conditions	Limit			Unit
			Min.	Typ.	Max.	
Saturated Drain Current	I_{DSS}	$V_{DS} = 5\text{V}, V_{GS} = 0\text{V}$	-	1000	1500	mA
Transconductance	g_m	$V_{DS} = 5\text{V}, I_{DS} = 600\text{mA}$	-	500	-	mS
Pinch-off Voltage	V_p	$V_{DS} = 5\text{V}, I_{DS} = 50\text{mA}$	-1.0	-2.0	-3.5	V
Gate Source Breakdown Voltage	V_{GSO}	$I_{GS} = -50\mu\text{A}$	-5	-	-	V
Output Power at 1dB G.C.P.	P_{1dB}	$V_{DS} = 10\text{V},$ $I_{DS} = 0.6 I_{DSS} \text{(Typ.)},$ $f = 8.5 \text{GHz}$	32.5	34.0	-	dBm
Power Gain at 1dB G.C.P.	G_{1dB}		7.0	8.0	-	dB
Power-added Efficiency	η_{add}		-	35	-	%
Thermal Resistance	R_{th}	Channel to Case	-	8	10	$^\circ\text{C/W}$

CASE STYLE: MH

G.C.P.: Gain Compression Point

FLC257MH-8

C-Band Power GaAs FET

POWER DERATING CURVE

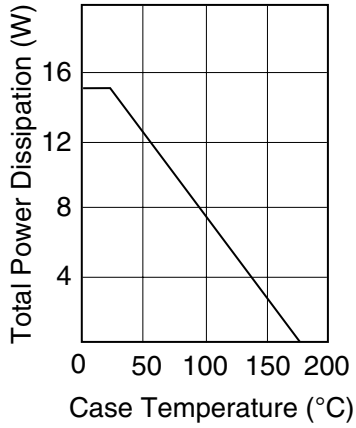

DRAIN CURRENT vs. DRAIN-SOURCE VOLTAGE

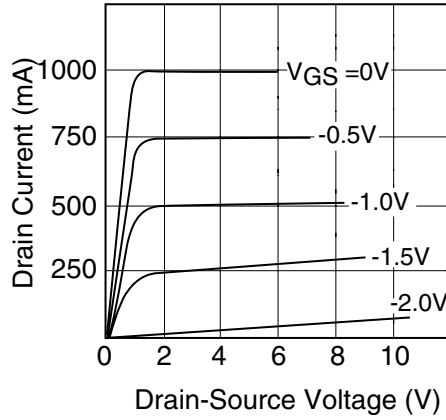

OUTPUT POWER & IM₃ vs. INPUT POWER

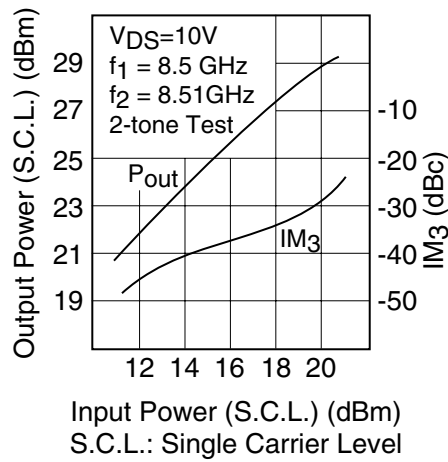

OUTPUT POWER vs. INPUT POWER

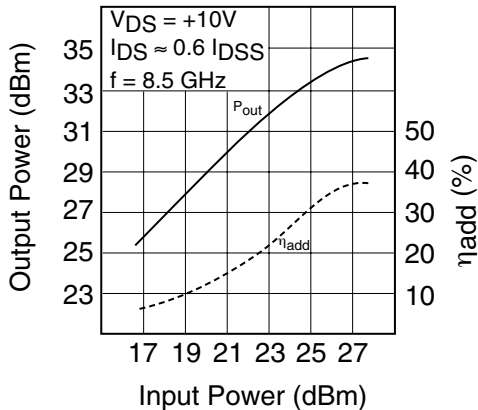

P_{1dB} & η_{add} vs. V_{DS}

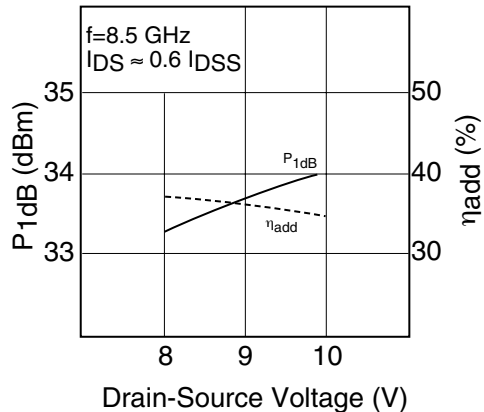

FLC257MH-8

C-Band Power GaAs FET

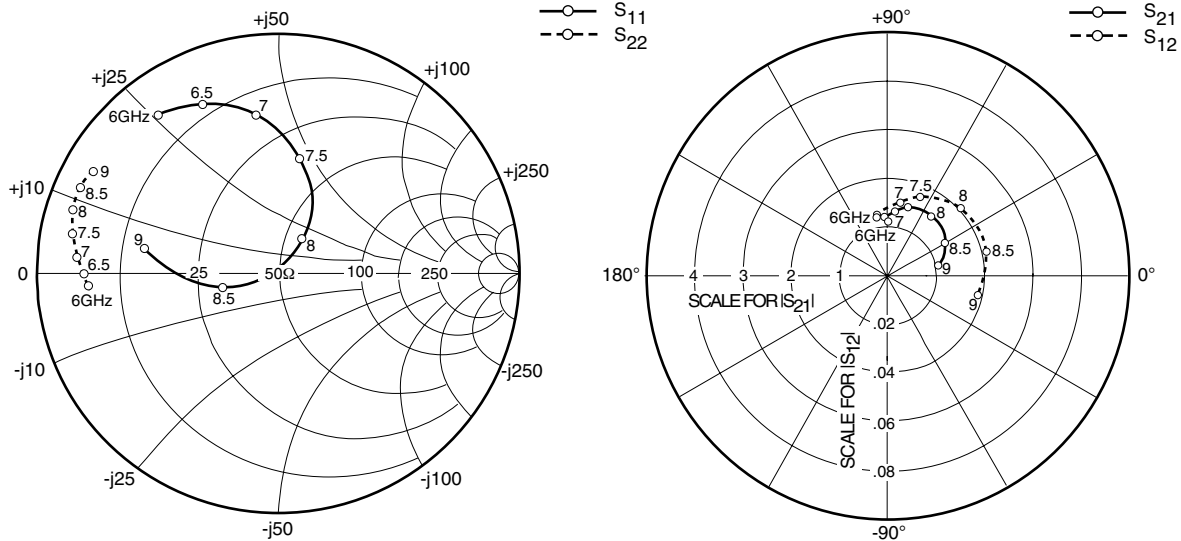

S-PARAMETERS

$V_{DS} = 10V, I_{DS} = 600mA$

FREQUENCY (MHZ)	S11		S21		S12		S22	
	MAG	ANG	MAG	ANG	MAG	ANG	MAG	ANG
500	.928	-142.8	7.163	109.2	.021	28.8	.344	-157.2
6000	.826	127.2	1.097	90.1	.025	99.3	.778	-174.5
6500	.770	114.2	1.179	92.6	.026	98.5	.798	-179.6
7000	.666	98.0	1.270	84.3	.030	81.0	.834	175.7
7500	.485	78.9	1.453	73.2	.035	67.7	.863	169.2
8000	.170	55.0	1.500	53.1	.041	43.3	.894	162.7
8500	.243	-164.9	1.368	29.9	.042	14.0	.889	156.1
9000	.561	170.0	1.053	10.3	.038	-12.0	.874	150.6
9500	.740	150.0	.758	-1.9	.029	-29.6	.848	146.0
10000	.828	134.3	.569	-9.3	.023	-40.1	.846	143.4

FLC257MH-8

C-Band Power GaAs FET

Case Style "MH" Metal-Ceramic Hermetic Package

