

# FLC257MH-6

## C-Band Power GaAs FET

### FEATURES

- High Output Power:  $P_{1dB} = 34.0dBm(Typ.)$
- High Gain:  $G_{1dB} = 9.0dB(Typ.)$
- High PAE:  $\eta_{add} = 36\%(Typ.)$
- Proven Reliability
- Hermetic Metal/Ceramic Package

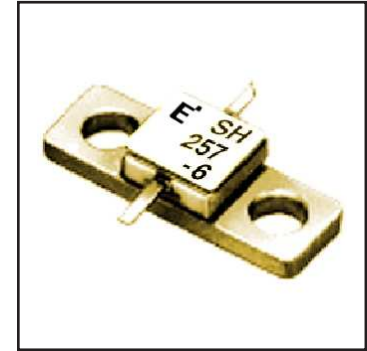

### DESCRIPTION

The FLC257MH-6 is a power GaAs FET that is designed for general purpose applications in the C-Band frequency range as it provides superior power, gain, and efficiency.

Eudyna stringent Quality Assurance Program assures the highest reliability and consistent performance.

### ABSOLUTE MAXIMUM RATING (Ambient Temperature $T_a=25^\circ C$ )

Item	Symbol	Condition	Rating	Unit
Drain-Source Voltage	$V_{DS}$		15	V
Gate-Source Voltage	$V_{GS}$		-5	V
Total Power Dissipation	$P_T$	$T_C = 25^\circ C$	15	W
Storage Temperature	$T_{stg}$		-65 to +175	$^\circ C$
Channel Temperature	$T_{ch}$		175	$^\circ C$

Eudyna recommends the following conditions for the reliable operation of GaAs FETs:

1. The drain-source operating voltage ( $V_{DS}$ ) should not exceed 10 volts.
2. The forward and reverse gate currents should not exceed 17.8 and -1.2 mA respectively with gate resistance of 200 $\Omega$ .
3. The operating channel temperature ( $T_{ch}$ ) should not exceed 145 $^\circ C$ .

### ELECTRICAL CHARACTERISTICS (Ambient Temperature $T_a=25^\circ C$ )

Item	Symbol	Test Conditions	Limit			Unit
			Min.	Typ.	Max.	
Saturated Drain Current	$I_{DSS}$	$V_{DS} = 5V, V_{GS} = 0V$	-	1000	1500	mA
Transconductance	$g_m$	$V_{DS} = 5V, I_{DS} = 600mA$	-	500	-	mS
Pinch-off Voltage	$V_p$	$V_{DS} = 5V, I_{DS} = 50mA$	-1.0	-2.0	-3.5	V
Gate Source Breakdown Voltage	$V_{GSO}$	$I_{GS} = -50\mu A$	-5	-	-	V
Output Power at 1dB G.C.P.	$P_{1dB}$	$V_{DS} = 10V,$ $I_{DS} = 0.6 I_{DSS} (Typ.),$ $f = 6.4 GHz$	32.5	34.0	-	dBm
Power Gain at 1dB G.C.P.	$G_{1dB}$		8.0	9.0	-	dB
Power-added Efficiency	$\eta_{add}$		-	36	-	%
Thermal Resistance	$R_{th}$	Channel to Case	-	8	10	$^\circ C/W$

CASE STYLE: MH

G.C.P.: Gain Compression Point

**Eudyna**

# FLC257MH-6

## C-Band Power GaAs FET

**POWER DERATING CURVE**

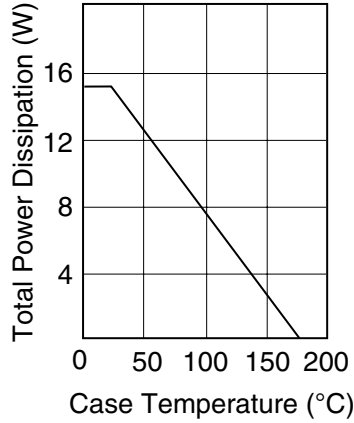

**DRAIN CURRENT vs. DRAIN-SOURCE VOLTAGE**

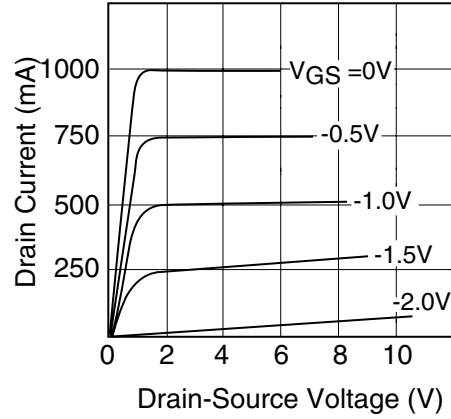

**OUTPUT POWER & IM<sub>3</sub> vs. INPUT POWER**

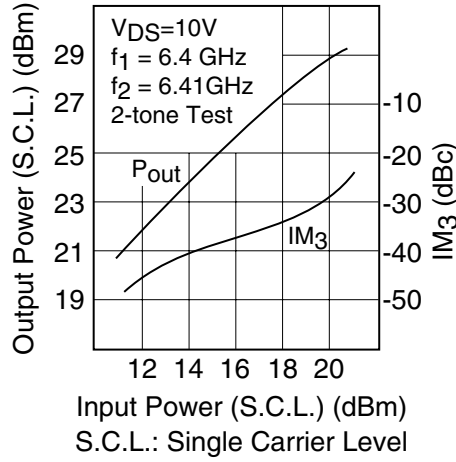

**OUTPUT POWER vs. INPUT POWER**

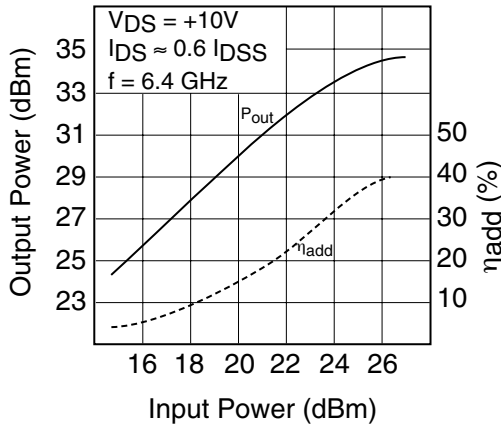

**P<sub>1dB</sub> & η<sub>add</sub> vs. V<sub>DS</sub>**

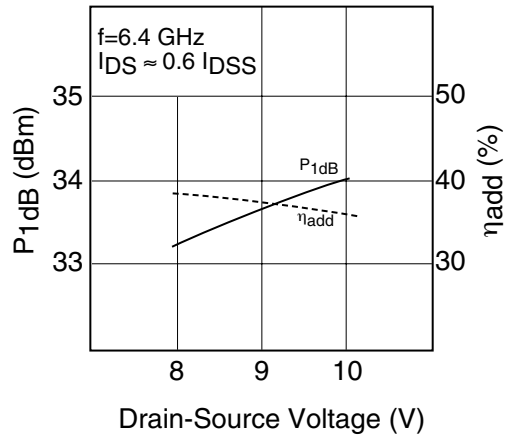

# FLC257MH-6

## C-Band Power GaAs FET

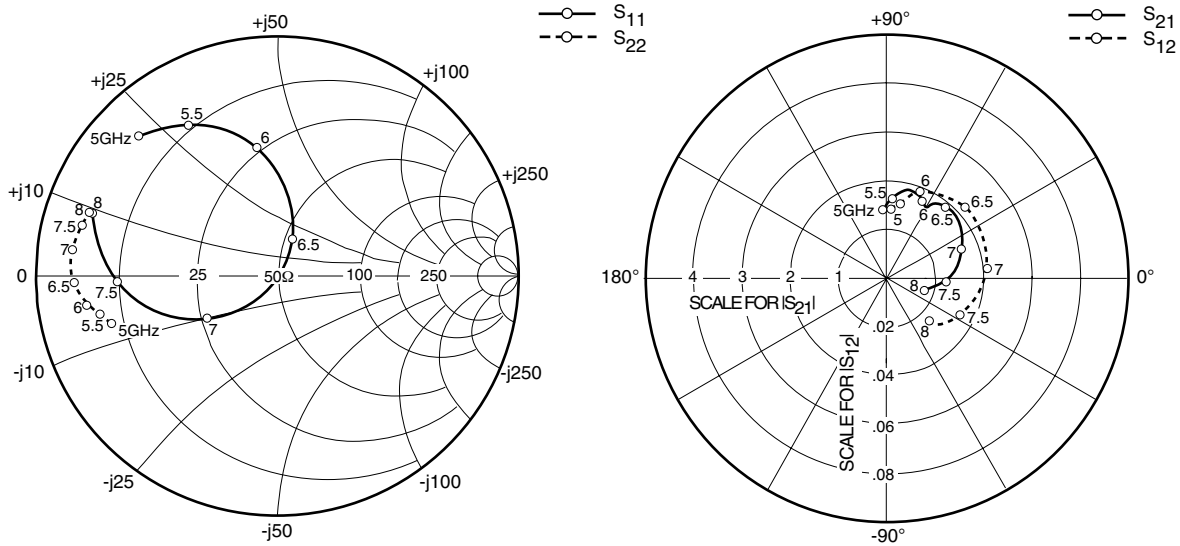

### S-PARAMETERS

$V_{DS} = 10V, I_{DS} = 600mA$

FREQUENCY (MHZ)	S11		S21		S12		S22	
	MAG	ANG	MAG	ANG	MAG	ANG	MAG	ANG
500	.937	-142.8	7.241	109.5	.020	30.3	.351	-157.1
5000	.818	134.9	1.418	91.8	.029	86.1	.719	-163.9
5500	.729	120.3	1.596	85.8	.031	79.7	.751	-167.5
6000	.542	99.1	1.737	64.9	.038	69.2	.800	-170.6
6500	.166	67.8	1.912	50.3	.044	41.5	.839	-178.0
7000	.338	-148.2	1.664	20.5	.042	5.6	.856	172.9
7500	.667	-177.6	1.231	-1.8	.034	-25.6	.832	165.7
8000	.814	161.6	.810	-16.0	.025	-44.4	.825	160.9

# FLC257MH-6

C-Band Power GaAs FET

## Case Style "MH" Metal-Ceramic Hermetic Package

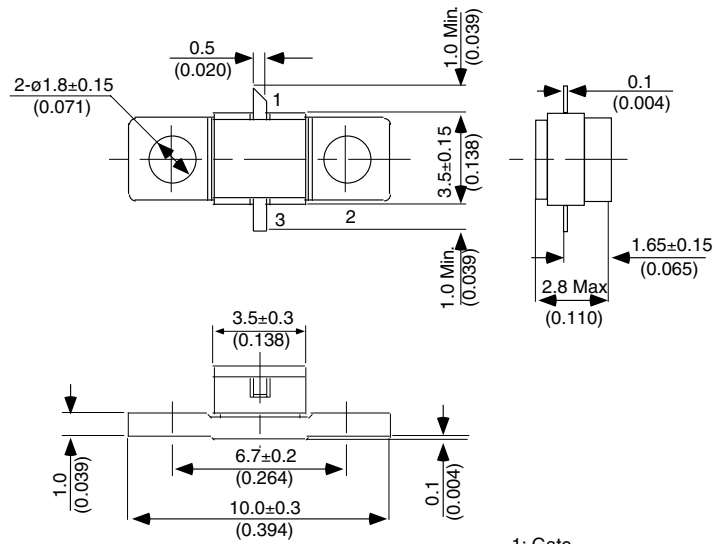

1: Gate  
2: Source (Flange)  
3: Drain  
Unit: mm (Inches)