

# FLC167WF

## C-Band Power GaAs FET

### FEATURES

- High Output Power:  $P_{1dB} = 31.8\text{dBm(Typ.)}$
- High Gain:  $G_{1dB} = 7.5\text{dB(Typ.)}$
- High PAE:  $\eta_{add} = 35\%(\text{Typ.})$
- Proven Reliability
- Hermetic Metal/Ceramic Package

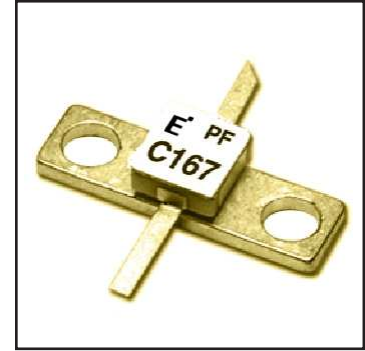

### DESCRIPTION

The FLC167WF is a power GaAs FET that is designed for general purpose applications in the C-Band frequency range as it provides superior power, gain, and efficiency.

Eudyna stringent Quality Assurance Program assures the highest reliability and consistent performance.

### ABSOLUTE MAXIMUM RATING (Ambient Temperature $T_a=25^\circ\text{C}$ )

Item	Symbol	Condition	Rating	Unit
Drain-Source Voltage	$V_{DS}$		15	V
Gate-Source Voltage	$V_{GS}$		-5	V
Total Power Dissipation	$P_T$	$T_C = 25^\circ\text{C}$	7.5	W
Storage Temperature	$T_{stg}$		-65 to +175	$^\circ\text{C}$
Channel Temperature	$T_{ch}$		175	$^\circ\text{C}$

Eudyna recommends the following conditions for the reliable operation of GaAs FETs:

1. The drain-source operating voltage ( $V_{DS}$ ) should not exceed 10 volts.
2. The forward and reverse gate currents should not exceed 9.6 and -1.0 mA respectively with gate resistance of  $200\Omega$ .
3. The operating channel temperature ( $T_{ch}$ ) should not exceed  $145^\circ\text{C}$ .

### ELECTRICAL CHARACTERISTICS (Ambient Temperature $T_a=25^\circ\text{C}$ )

Item	Symbol	Test Conditions	Limit			Unit
			Min.	Typ.	Max.	
Saturated Drain Current	$I_{DSS}$	$V_{DS} = 5\text{V}, V_{GS} = 0\text{V}$	-	600	900	mA
Transconductance	$g_m$	$V_{DS} = 5\text{V}, I_{DS} = 400\text{mA}$	-	300	-	mS
Pinch-off Voltage	$V_p$	$V_{DS} = 5\text{V}, I_{DS} = 30\text{mA}$	-1.0	-2.0	-3.5	V
Gate Source Breakdown Voltage	$V_{GSO}$	$I_{GS} = -30\mu\text{A}$	-5	-	-	V
Output Power at 1dB G.C.P.	$P_{1dB}$	$V_{DS} = 10\text{V},$ $I_{DS} = 0.6 I_{DSS} (\text{Typ.}),$ $f = 6\text{GHz}$	30.5	31.8	-	dBm
Power Gain at 1dB G.C.P.	$G_{1dB}$		6.5	7.5	-	dB
Power-added Efficiency	$\eta_{add}$		-	35	-	%
Thermal Resistance	$R_{th}$	Channel to Case	-	15	20	$^\circ\text{C/W}$

CASE STYLE: WF

G.C.P.: Gain Compression Point

**Eudyna**

# FLC167WF

## C-Band Power GaAs FET

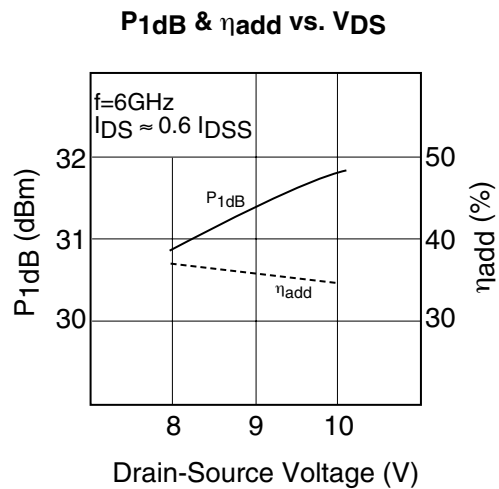
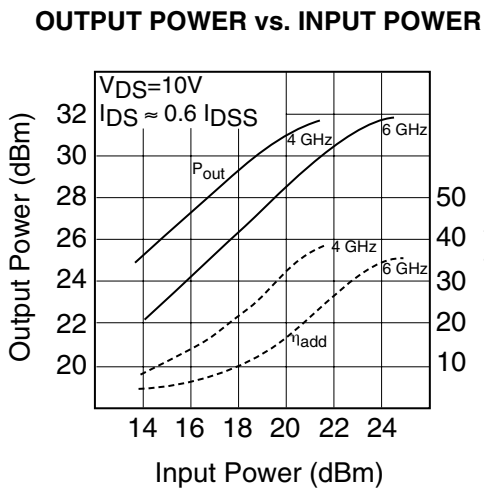
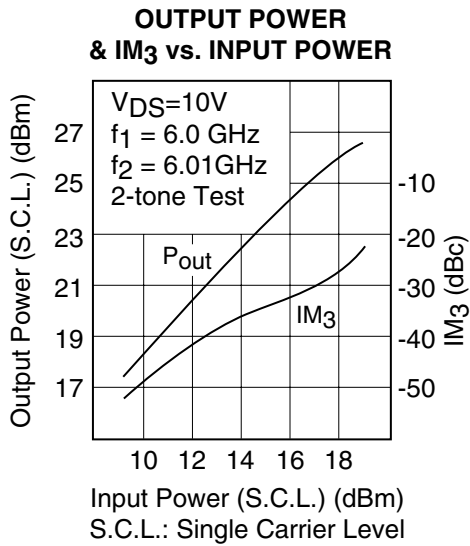
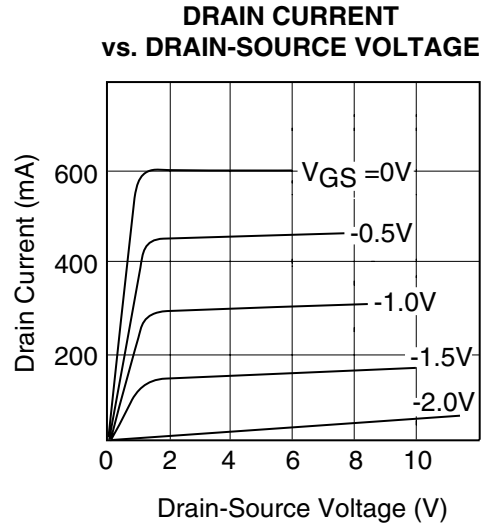
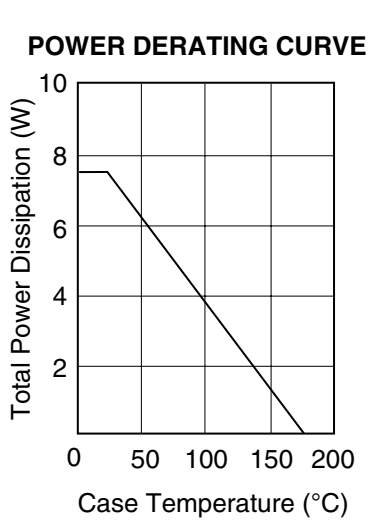

# FLC167WF

## C-Band Power GaAs FET

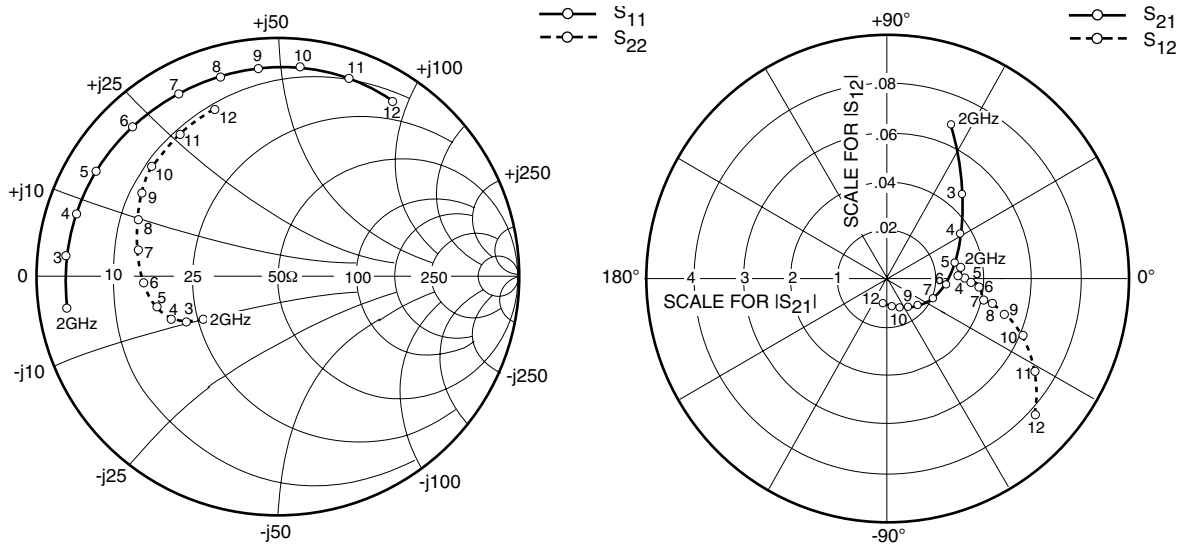

### S-PARAMETERS

$V_{DS} = 10V, I_{DS} = 360mA$

FREQUENCY (MHZ)	S11		S21		S12		S22	
	MAG	ANG	MAG	ANG	MAG	ANG	MAG	ANG
500	.922	-104.6	11.190	119.4	.025	36.5	.234	-124.6
1000	.895	-142.7	6.587	94.0	.029	18.2	.290	-142.9
2000	.887	-171.4	3.424	67.1	.030	5.3	.360	-150.5
3000	.884	174.4	2.295	47.9	.030	1.0	.423	-153.5
4000	.877	163.1	1.762	30.6	.031	0.1	.475	-158.3
5000	.873	149.8	1.452	13.0	.034	-1.9	.511	-165.9
6000	.870	134.2	1.227	-6.0	.038	-5.5	.547	-177.6
7000	.867	118.6	1.019	-24.9	.040	-12.7	.585	168.5
8000	.860	106.0	.843	-40.9	.044	-13.1	.625	157.3
9000	.866	95.5	.725	-54.7	.051	-17.7	.664	148.4
10000	.875	84.0	.656	-69.2	.060	-22.9	.692	138.4
11000	.877	70.5	.596	-85.7	.072	-32.1	.717	124.3
12000	.871	57.3	.525	-101.4	.082	-42.2	.747	110.6

### Case Style "WF"

### Metal-Ceramic Hermetic Package

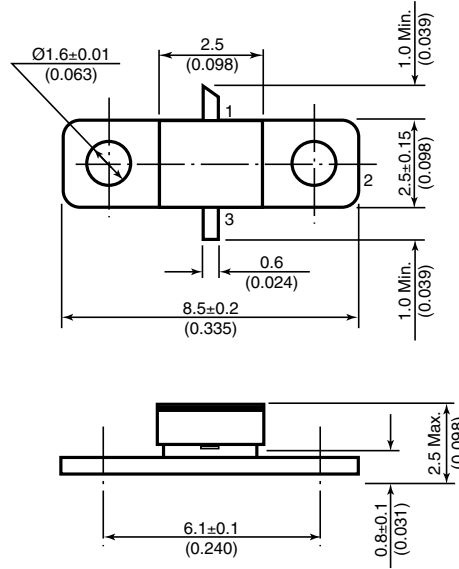

1. Gate
2. Source (Flange)
3. Drain
4. Source (Flange)

Unit: mm(inches)