

FEATURES

- High Output Power: $P_{1dB} = 36.0\text{dBm}$ (Typ.)
- High Gain: $G_{1dB} = 11.5\text{dB}$ (Typ.)
- High PAE: $\eta_{add} = 37\%$ (Typ.)
- Proven Reliability
- Hermetically Sealed Package

DESCRIPTION

The FLL57MK is a Power GaAs FET that is specifically designed to provide high power at L-Band frequencies with gain, linearity and efficiency superior to that of silicon devices. The performance in multitone environments for Class AB operation make them ideally suited for base station applications.

Fujitsu's stringent Quality Assurance Program assures the highest reliability and consistent performance.



ABSOLUTE MAXIMUM RATING (Ambient Temperature $T_a=25^\circ\text{C}$)

Item	Symbol	Condition	Rating	Unit
Drain-Source Voltage	V_{DS}		15	V
Gate-Source Voltage	V_{GS}		-5	V
Total Power Dissipation	P_T	$T_C = 25^\circ\text{C}$	21.4	W
Storage Temperature	T_{stg}		-65 to +175	$^\circ\text{C}$
Channel Temperature	T_{ch}		175	$^\circ\text{C}$

Fujitsu recommends the following conditions for the reliable operation of GaAs FETs:

1. The drain-source operating voltage (V_{DS}) should not exceed 10 volts.
2. The forward and reverse gate currents should not exceed 32.2 and -2.2 mA respectively with gate resistance of 100Ω .
3. The operating channel temperature (T_{ch}) should not exceed 145°C .

ELECTRICAL CHARACTERISTICS (Ambient Temperature $T_a=25^\circ\text{C}$)

Item	Symbol	Test Conditions	Limit			Unit
			Min.	Typ.	Max.	
Saturated Drain Current	I_{DSS}	$V_{DS} = 5\text{V}, V_{GS} = 0\text{V}$	-	1800	2700	mA
Transconductance	g_m	$V_{DS} = 5\text{V}, I_{DS} = 1100\text{mA}$	-	1000	-	mS
Pinch-off Voltage	V_p	$V_{DS} = 5\text{V}, I_{DS} = 90\text{mA}$	-1.0	-2.0	-3.5	V
Gate Source Breakdown Voltage	V_{GSO}	$I_{GS} = -90\mu\text{A}$	-5	-	-	V
Output Power at 1dB G.C.P.	P_{1dB}	$V_{DS} = 10\text{V}$ $I_{DS} = 0.55I_{DSS}$ (Typ.), $f = 2.3\text{GHz}$	35.5	36.0	-	dBm
Power Gain at 1dB G.C.P.	G_{1dB}		10.5	11.5	-	dB
Power-added Efficiency	η_{add}		-	37	-	%
Thermal Resistance	R_{th}	Channel to Case	-	6.2	7.0	$^\circ\text{C}/\text{W}$

CASE STYLE: MK

G.C.P.: Gain Compression Point

FLL57MK

L-Band Medium & High Power GaAs FET

POWER DERATING CURVE

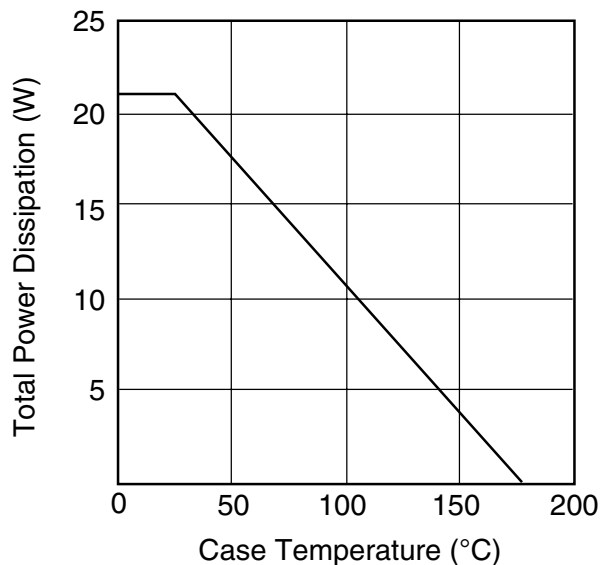

DRAIN CURRENT vs. DRAIN-SOURCE VOLTAGE

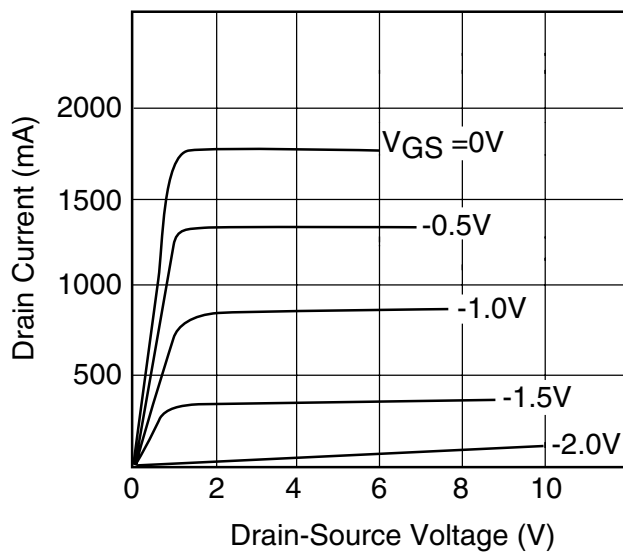

OUTPUT POWER vs. INPUT POWER

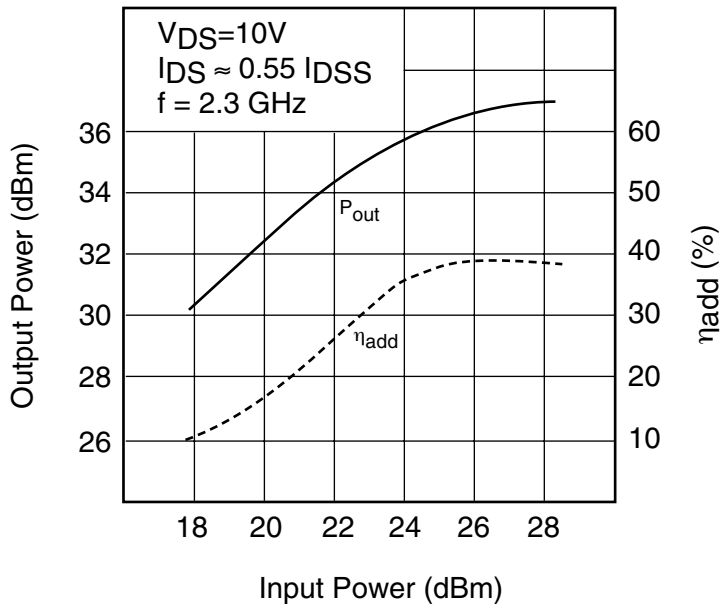

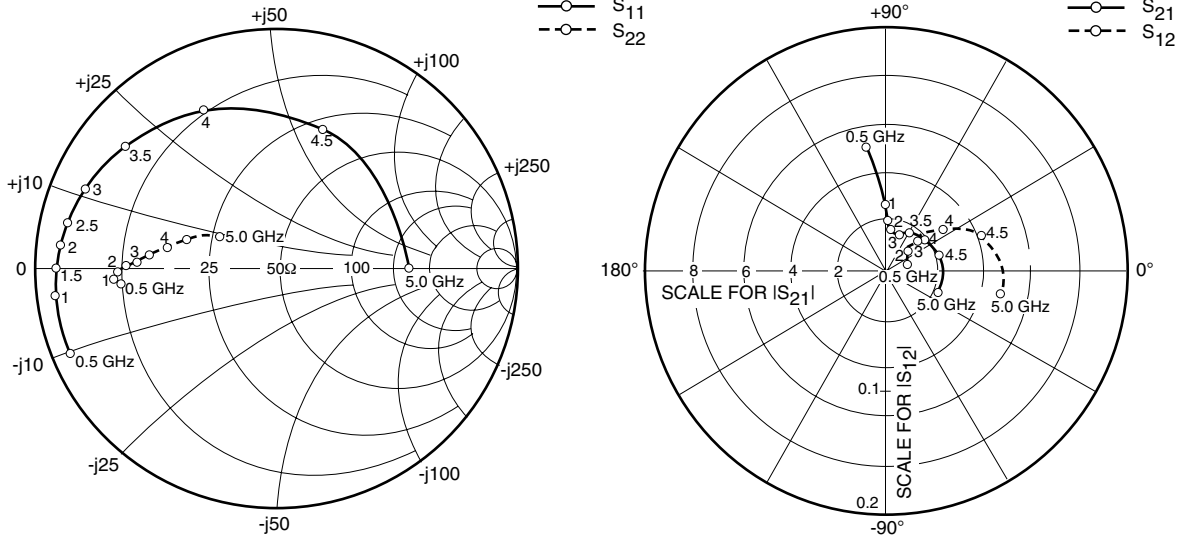

S-PARAMETERS

$V_{DS} = 10V, I_{DS} = 800mA$

FREQUENCY (MHZ)	S11		S21		S12		S22	
	MAG	ANG	MAG	ANG	MAG	ANG	MAG	ANG
500	.929	-157.5	5.115	99.7	.017	21.7	.661	-175.9
1000	.927	-172.6	2.718	91.4	.018	24.6	.669	-176.5
1500	.914	179.9	1.988	88.3	.020	34.4	.660	-177.7
2000	.902	174.0	1.653	83.8	.022	41.1	.651	-178.8
2500	.887	167.6	1.558	79.4	.026	48.7	.621	179.8
3000	.856	157.0	1.534	72.3	.034	42.7	.584	177.7
3500	.806	140.9	1.782	60.2	.040	47.0	.527	174.3
4000	.725	114.8	1.888	39.3	.057	35.5	.465	169.3
4500	.609	71.9	2.199	15.8	.082	19.7	.396	162.0
5000	.548	-0.6	2.278	-24.0	.096	-11.8	.270	151.1

FLL57MK

L-Band Medium & High Power GaAs FET

Case Style "MK" Metal-Ceramic Hermetic Package

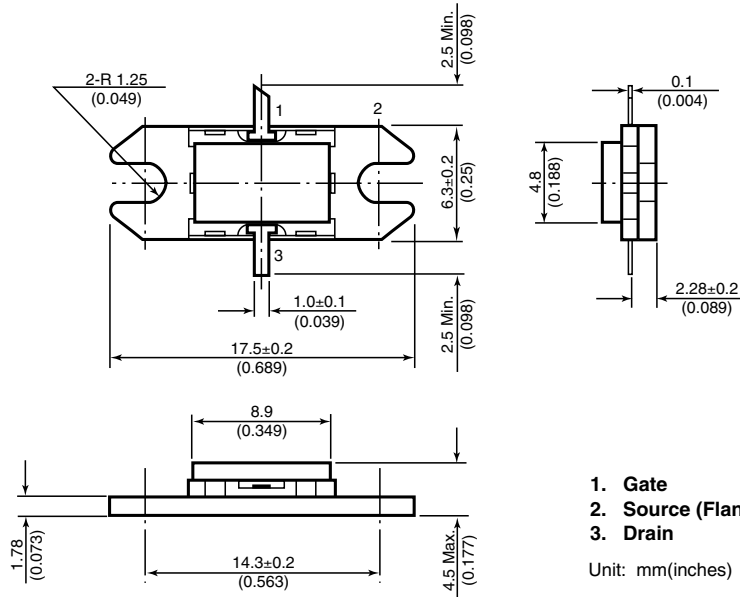

For further information please contact:

FUJITSU COMPOUND SEMICONDUCTOR, INC.

2355 Zanker Rd.
San Jose, CA 95131-1138, U.S.A.
Phone: (408) 232-9500
FAX: (408) 428-9111
www.fcsi.fujitsu.com

FUJITSU MICROELECTRONICS, LTD.

Compound Semiconductor Division
Network House
Norreys Drive
Maidenhead, Berkshire SL6 4FJ
Phone: +44 (0)1628 504800
FAX: +44 (0)1628 504888

CAUTION

Fujitsu Compound Semiconductor Products contain **gallium arsenide (GaAs)** which can be hazardous to the human body and the environment. For safety, observe the following procedures:

- Do not put these products into the mouth.
- Do not alter the form of this product into a gas, powder, or liquid through burning, crushing, or chemical processing as these by-products are dangerous to the human body if inhaled, ingested, or swallowed.
- Observe government laws and company regulations when discarding this product. This product must be discarded in accordance with methods specified by applicable hazardous waste procedures.

Fujitsu Limited reserves the right to change products and specifications without notice. The information does not convey any license under rights of Fujitsu Limited or others.

© 1998 FUJITSU COMPOUND SEMICONDUCTOR, INC.

Printed in U.S.A. FCSI0598M200

FUJITSU