

FEATURES

- High Output Power: $P_{1dB}=35.5dBm$ (Typ.)
- High Gain: $G_{1dB}=11.5dB$ (Typ.)
- High PAE: $\eta_{add}=46%$ (Typ.)
- Proven Reliability
- Hermetically Sealed Package



DESCRIPTION

The FLL357ME is a Power GaAs FET that is specifically designed to provide high power at L-Band frequencies with gain, linearity and efficiency superior to that of silicon devices. The performance in multitone environments for Class AB operation make them ideally suited for base station applications. This device is assembled in hermetic metal/ceramic package.

Eudyna stringent Quality Assurance Program assures the highest reliability and consistent performance.

ABSOLUTE MAXIMUM RATING (Ambient Temperature $T_a=25^\circ C$)

Item	Symbol	Condition	Rating	Unit
Drain-Source Voltage	V_{DS}		15	V
Gate-Source Voltage	V_{GS}		-5	V
Total Power Dissipation	P_{tot}	$T_c = 25^\circ C$	15	W
Storage Temperature	T_{stg}		-65 to +175	$^\circ C$
Channel Temperature	T_{ch}		175	$^\circ C$

Eudyna recommends the following conditions for the reliable operation of GaAs FETs:

1. The drain-source operating voltage (V_{DS}) should not exceed 10 volts.
2. The forward and reverse gate currents should not exceed 19.4 and -2.0 mA respectively with gate resistance of 100 Ω .
3. The operating channel temperature (T_{ch}) should not exceed 145 $^\circ C$.

ELECTRICAL CHARACTERISTICS (Ambient Temperature $T_a=25^\circ C$)

Item	Symbol	Test Conditions	Limit			Unit
			Min.	Typ.	Max.	
Saturated Drain Current	I_{DSS}	$V_{DS} = 5V, V_{GS} = 0V$	-	1200	1800	mA
Transconductance	g_m	$V_{DS} = 5V, I_{DS} = 800mA$	-	600	-	mS
Pinch-off Voltage	V_p	$V_{DS} = 5V, I_{DS} = 60mA$	-1.0	-2.0	-3.5	V
Gate Source Breakdown Voltage	V_{GSO}	$I_{GS} = -60\mu A$	-5	-	-	V
Output Power at 1dB G.C.P.	P_{1dB}	$V_{DS} = 10V$ $I_{DS} \approx 0.6I_{DSS}$ (Typ.), $f = 2.3GHz$	34.5	35.5	-	dBm
Power Gain at 1dB G.C.P.	G_{1dB}		10.5	11.5	-	dB
Power-added Efficiency	η_{add}		-	46	-	%
Thermal Resistance	R_{th}	Channel to Case	-	7.5	10	$^\circ C/W$

CASE STYLE: ME

G.C.P.: Gain Compression Point

FLL357ME

L-Band Medium & High Power GaAs FET

POWER DERATING CURVE

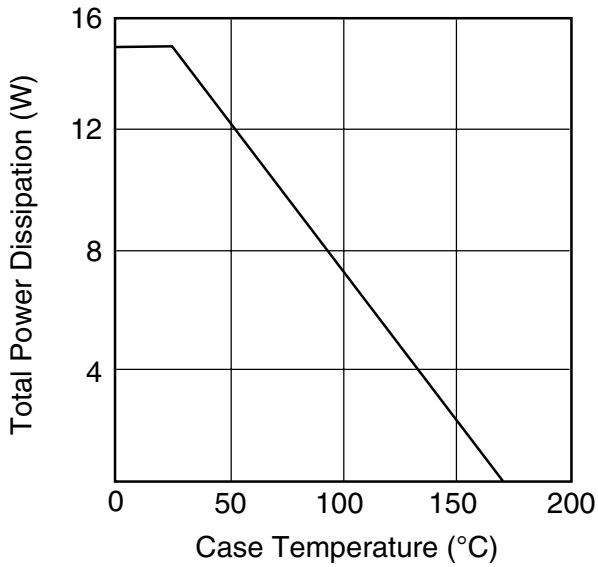

DRAIN CURRENT vs. DRAIN-SOURCE VOLTAGE

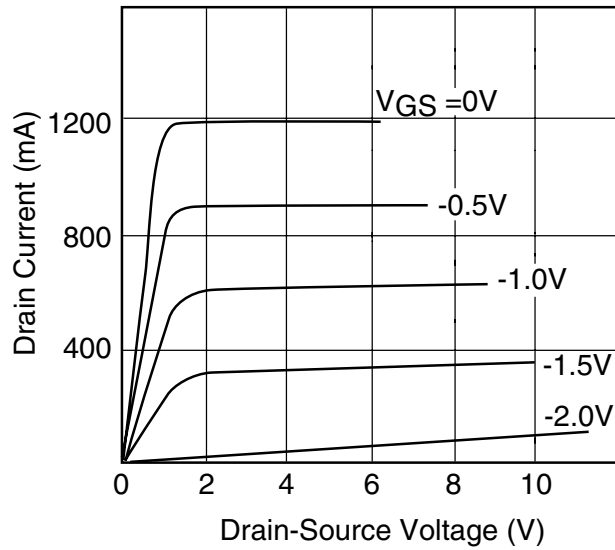

OUTPUT POWER vs. INPUT POWER

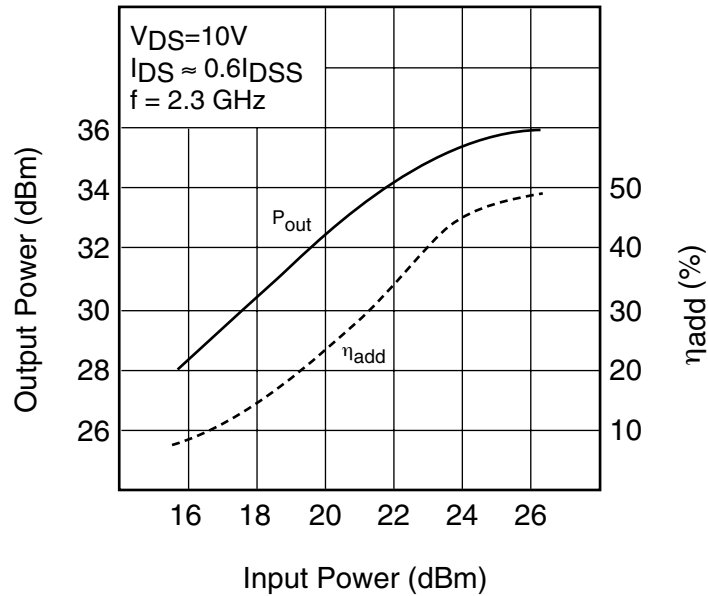

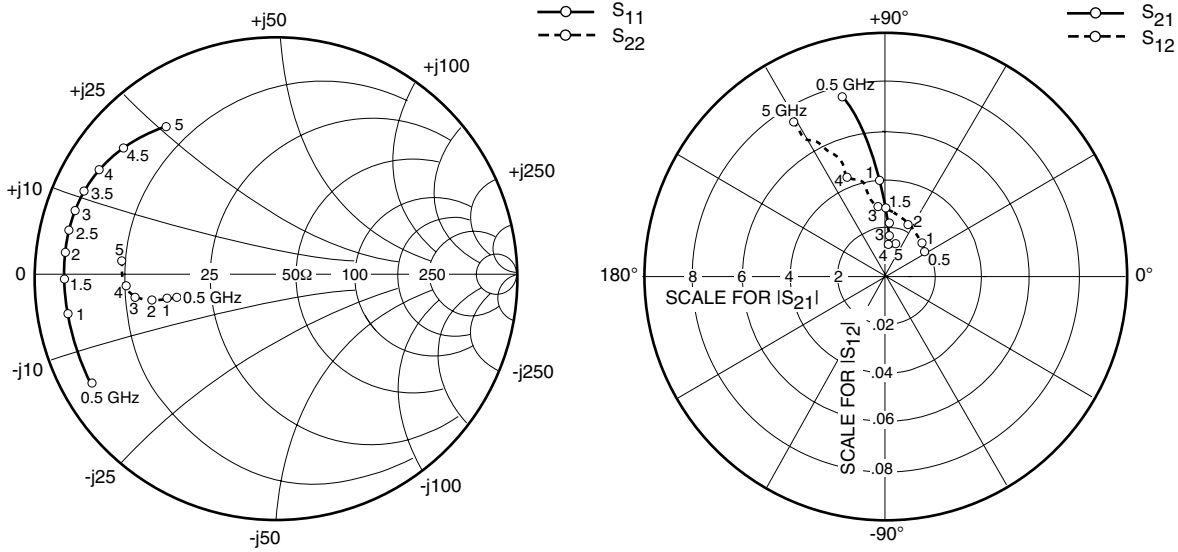

S-PARAMETERS

$V_{DS} = 10V, I_{DS} = 720mA$

FREQUENCY (MHZ)	S11		S21		S12		S22	
	MAG	ANG	MAG	ANG	MAG	ANG	MAG	ANG
500	.890	-149.0	7.584	103.7	.019	30.4	.427	-167.0
1000	.881	-169.3	3.963	94.3	.020	36.9	.461	-167.5
1500	.883	-179.0	2.747	90.3	.022	50.9	.491	-168.0
2000	.883	173.9	2.099	87.5	.023	64.9	.529	-168.1
2500	.882	168.1	1.708	87.1	.027	81.5	.560	-168.9
3000	.879	162.5	1.515	86.2	.028	94.6	.592	-170.5
3500	.872	156.7	1.304	86.6	.039	103.3	.613	-172.9
4000	.858	149.8	1.366	84.3	.044	111.8	.624	-175.1
4500	.826	140.4	1.223	81.5	.052	111.2	.639	-179.1
5000	.768	126.9	1.303	76.6	.074	120.7	.639	175.1

FLL357ME

L-Band Medium & High Power GaAs FET

Case Style "ME" Metal-Ceramic Hermetic Package

