

### FEATURES

- High Output Power:  $P_{1dB}=29.5\text{dBm}$  (Typ.)
- High Gain:  $G_{1dB}=14.5\text{dB}$  (Typ.)
- High PAE:  $\eta_{add}=47\%$  (Typ.)
- Hermetic Metal/Ceramic (SMT) Package
- Tape and Reel Available

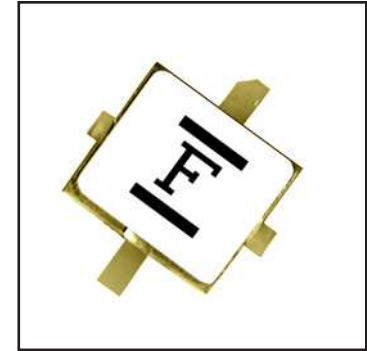

### DESCRIPTION

The FLU10XM is a GaAs FET designed for base station applications in the PCN/PCS frequency range. This is a new product series that uses a surface mount package that has been optimized for high volume cost driven applications.

Fujitsu's stringent Quality Assurance Program assures the highest reliability and consistent performance.

### ABSOLUTE MAXIMUM RATINGS (Ambient Temperature $T_a=25^\circ\text{C}$ )

Item	Symbol	Condition	Rating	Unit
Drain-Source Voltage	$V_{DS}$		15	V
Gate-Source Voltage	$V_{GS}$		-5	V
Total Power Dissipation	PT	$T_c = 25^\circ\text{C}$	4.16	W
Storage Temperature	$T_{stg}$		-65 to +175	$^\circ\text{C}$
Channel Temperature	$T_{ch}$		+175	$^\circ\text{C}$

Fujitsu recommends the following conditions for the reliable operation of GaAs FETs:

1. The drain-source operating voltage ( $V_{DS}$ ) should not exceed 10 volts.
2. The forward and reverse gate currents should not exceed 4.8 and -0.5 mA respectively with gate resistance of  $400\Omega$ .
3. The operating channel temperature ( $T_{ch}$ ) should not exceed  $145^\circ\text{C}$ .

### ELECTRICAL CHARACTERISTICS (Ambient Temperature $T_a=25^\circ\text{C}$ )

Item	Symbol	Conditions	Limits			Unit
			Min.	Typ.	Max.	
Drain Current	$I_{DSS}$	$V_{DS} = 5\text{V}, V_{GS}=0\text{V}$	-	300	450	mA
Transconductance	gm	$V_{DS} = 5\text{V}, I_{DS}=200\text{mA}$	-	150	-	mS
Pinch-Off Voltage	$V_p$	$V_{DS} = 5\text{V}, I_{DS}=15\text{mA}$	-1.0	-2.0	-3.5	V
Gate-Source Breakdown Voltage	$V_{GSO}$	$I_{GS} = -15\mu\text{A}$	-5	-	-	V
Output Power at 1 dB G.C.P.	$P_{1dB}$	$V_{DS} = 10\text{V}$ $f=2.0\text{GHz}$ $I_{DS}=0.6I_{DSS}$	28.5	29.5	-	dBm
Power Gain at 1 dB G.C.P.	$G_{1dB}$		13.5	14.5	-	dB
Power Added Efficiency	$\eta_{add}$		-	47	-	%
Thermal Resistance	$R_{th}$	Channel to Case	-	25	36	$^\circ\text{C}/\text{W}$

#### Case Style: XM

G.C.P.: Gain Compression Point

Note: The RF parameters are measured on a lot basis by sample testing at an AQL = 0.1%, Level-II inspection. Any lot failure shall be 100% retested.

# FLU10XM

## L-Band Medium & High Power GaAs FET

POWER DERATING CURVE

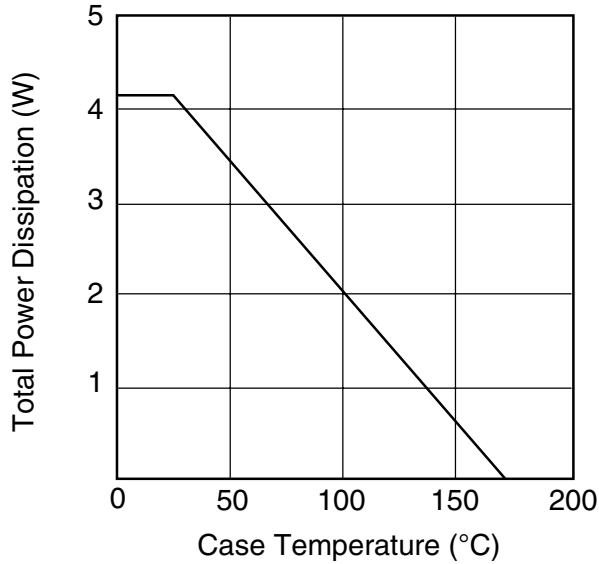

DRAIN CURRENT vs. DRAIN-SOURCE VOLTAGE

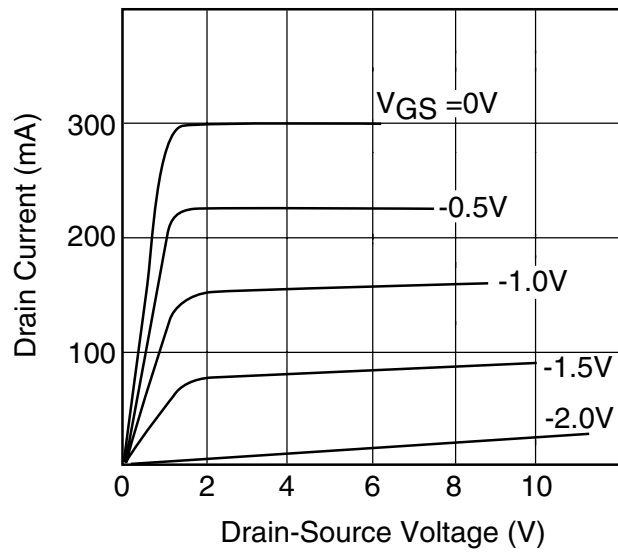

OUTPUT POWER vs. INPUT POWER

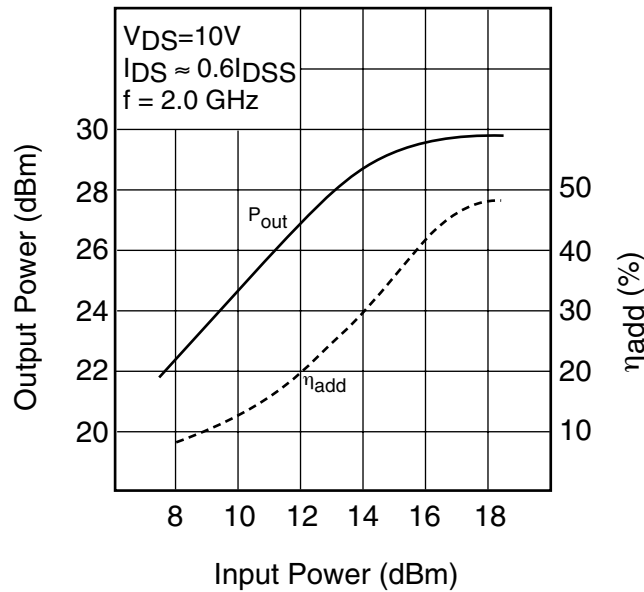

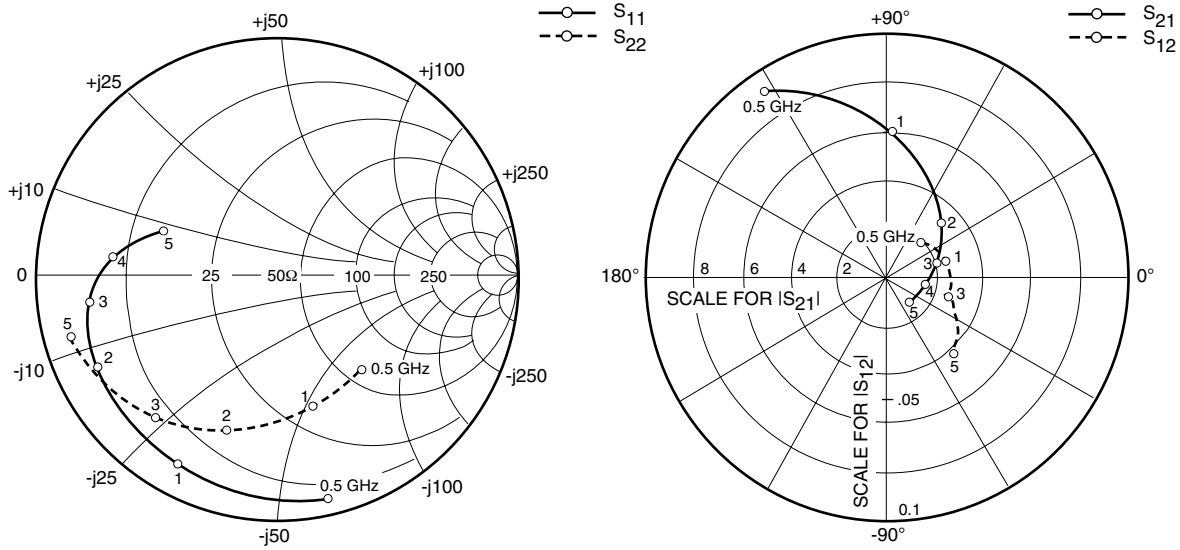

### S-PARAMETERS

$V_{DS} = 10V, I_{DS} = 180mA$

FREQUENCY (MHZ)	S11		S21		S12		S22	
	MAG	ANG	MAG	ANG	MAG	ANG	MAG	ANG
100	1.000	-17.7	11.904	167.3	.005	78.4	.535	-9.1
500	.922	-76.7	9.080	123.4	.020	43.2	.511	-46.1
1000	.864	-118.5	5.928	88.3	.026	14.5	.536	-74.7
1500	.841	-140.9	4.153	64.2	.028	4.8	.594	-94.0
2000	.825	-154.9	3.121	45.1	.028	-3.7	.654	-108.7
2500	.809	-164.9	2.498	28.4	.028	-12.0	.709	-120.9
3000	.783	-173.1	2.097	13.1	.028	-16.9	.755	-131.4
3500	.746	179.4	1.833	-1.9	.031	-20.5	.794	-140.9
4000	.692	172.0	1.655	-17.3	.034	-28.4	.830	-149.5
4500	.615	164.1	1.529	-33.6	.037	-36.3	.861	-157.3
5000	.507	156.6	1.429	-51.3	.042	-48.5	.886	-164.5

# FLU10XM

## L-Band Medium & High Power GaAs FET

### Case Style "XM" Metal-Ceramic Hermetic Package

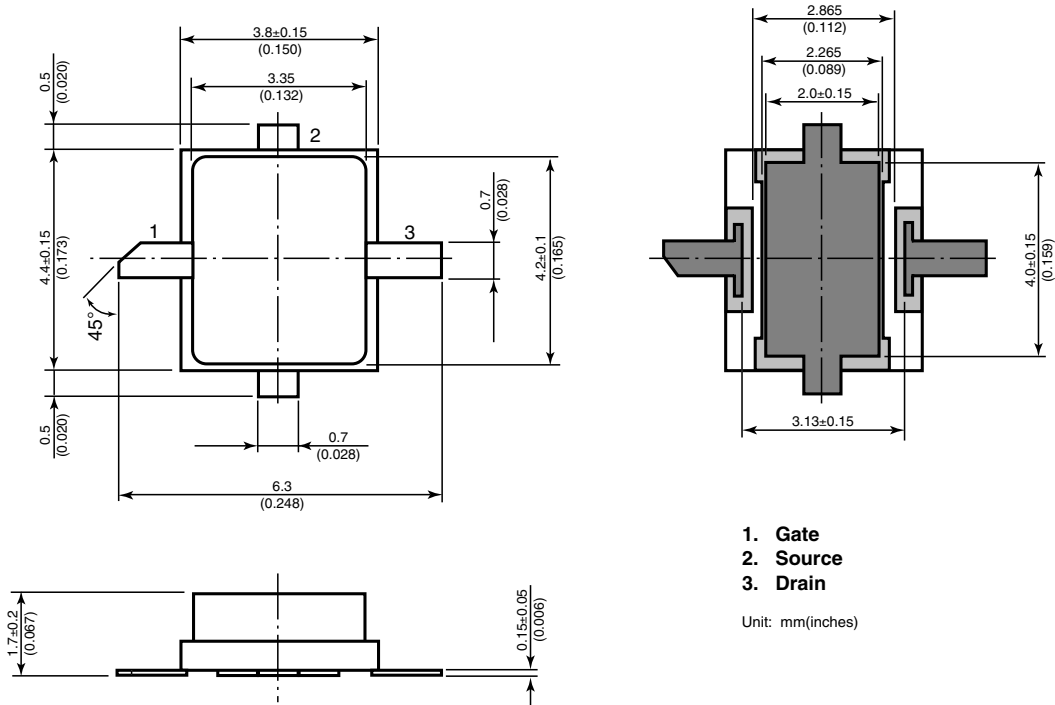

For further information please contact:

#### FUJITSU COMPOUND SEMICONDUCTOR, INC.

2355 Zanker Rd.  
San Jose, CA 95131-1138, U.S.A.  
Phone: (408) 232-9500  
FAX: (408) 428-9111  
www.fcsi.fujitsu.com

#### FUJITSU MICROELECTRONICS, LTD.

Compound Semiconductor Division  
Network House  
Norreys Drive  
Maidenhead, Berkshire SL6 4FJ  
Phone: +44 (0)1628 504800  
FAX: +44 (0)1628 504888

#### CAUTION

Fujitsu Compound Semiconductor Products contain **gallium arsenide (GaAs)** which can be hazardous to the human body and the environment. For safety, observe the following procedures:

- Do not put these products into the mouth.
- Do not alter the form of this product into a gas, powder, or liquid through burning, crushing, or chemical processing as these by-products are dangerous to the human body if inhaled, ingested, or swallowed.
- Observe government laws and company regulations when discarding this product. This product must be discarded in accordance with methods specified by applicable hazardous waste procedures.

Fujitsu Limited reserves the right to change products and specifications without notice. The information does not convey any license under rights of Fujitsu Limited or others.

© 1998 FUJITSU COMPOUND SEMICONDUCTOR, INC.

Printed in U.S.A. FCSI0598M200

**FUJITSU**