

### FEATURES

- High Output Power:  $P_{1dB} = 43.0\text{dBm}$  (Typ.)
- High Gain:  $G_{1dB} = 8.5\text{dB}$  (Typ.)
- High PAE:  $\eta_{add} = 35\%$  (Typ.)
- Low IM3 =  $-46\text{dBc}@P_o = 32.0\text{dBm}$
- Broad Band: 5.3 to 5.9GHz
- Impedance Matched  $Z_{in}/Z_{out} = 50\text{ohm}$

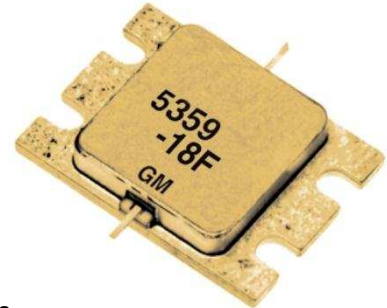

### DESCRIPTION

The FLM5359-18F is a power GaAs FET that is internally matched for standard communication bands to provide optimum power and gain in a 50 ohm system.

SEDI's stringent Quality Assurance Program assures the highest reliability and consistent performance.

### ABSOLUTE MAXIMUM RATING (Ambient Temperature $T_a=25\text{deg.C}$ )

Item	Symbol	Condition	Rating	Unit
Drain-Source Voltage	$V_{DS}$		15	V
Gate-Source Voltage	$V_{GS}$		-5	V
Total Power Dissipation	$P_T$	$T_c = 25\text{deg.C}$	83.3	W
Storage Temperature	$T_{stg}$		-65 to +175	deg.C
Channel Temperature	$T_{ch}$		175	deg.C

SEDI recommends the following conditions for the reliable operation of GaAs FETs:

1. The drain-source operating voltage ( $V_{DS}$ ) should not exceed 10 volts.
2. The forward and reverse gate currents should not exceed 26.0 and -11.6 mA respectively with gate resistance of 25ohm.

### ELECTRICAL CHARACTERISTICS (Ambient Temperature $T_a=25\text{deg.C}$ )

Item	Symbol	Test Conditions	Limit			Unit
			Min.	Typ.	Max.	
Saturated Drain Current	$I_{DSS}$	$V_{DS}=5V, V_{GS}=0V$	-	9.0	13.5	A
Transconductance	$g_m$	$V_{DS}=5V, I_{DS}=4800\text{mA}$	-	4000	-	mS
Pinch-off Voltage	$V_p$	$V_{DS}=5V, I_{DS}=480\text{mA}$	-1.0	-2.0	-3.5	V
Gate Source Breakdown Voltage	$V_{GSO}$	$I_{GS}=-480\text{uA}$	-5.0	-	-	V
Output Power at 1dB G.C.P.	$P_{1dB}$	$V_{DS}=10V,$	42.0	43.0	-	dBm
Power Gain at 1dB G.C.P.	$G_{1dB}$	$I_{DS}=0.55 I_{DSS}$ (Typ.),	7.5	8.5	-	dB
Drain Current	$I_{dsr}$	$f=5.3$ to $5.9$ GHz,	-	4800	6000	mA
Power-added Efficiency	$\eta_{add}$	$Z_S=Z_L=50\text{ohm}$	-	35	-	%
Gain Flatness	$\Delta G$		-	-	+/-0.6	dB
3rd Order Intermodulation Distortion	$IM_3$	$f = 5.9$ GHz, $\Delta f = 10$ MHz 2-Tone Test $P_{out} = 32.0\text{dBm}$ S.C.L.	-44	-46	-	dBc
Thermal Resistance	$R_{th}$	Channel to Case	-	1.6	1.8	deg.C/W
Channel Temperature Rise	$\Delta T_{ch}$	$10V \times I_{dsr} \times R_{th}$	-	-	80	deg.C

G.C.P.: Gain Compression Point, S.C.L.: Single Carrier Level

<b>CASE STYLE</b>	<b>IK</b>
-------------------	-----------

<b>ESD</b>	<b>Class 3A</b>	<b>4000V to 8000V</b>
------------	-----------------	-----------------------

Note : Based on EIAJ ED-4701 C-111A (C=100pF, R=1.5kohm)

<b>RoHS Compliance</b>	<b>Yes</b>
------------------------	------------

**POWER DERATING CURVE**

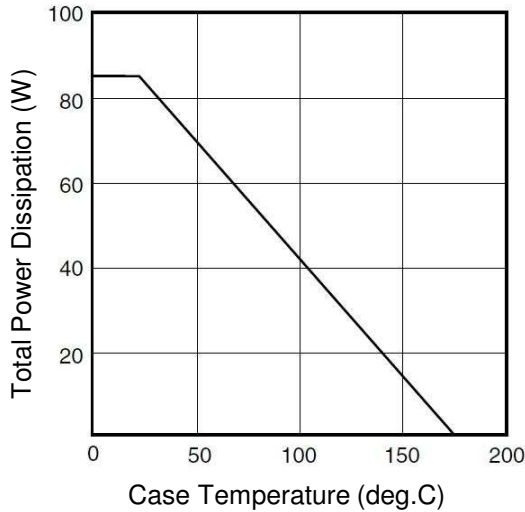

**OUTPUT POWER & IM<sub>3</sub> vs. INPUT POWER**

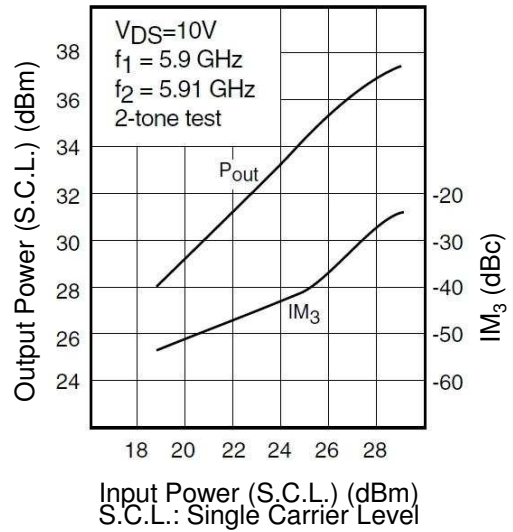

**OUTPUT POWER vs. FREQUENCY**

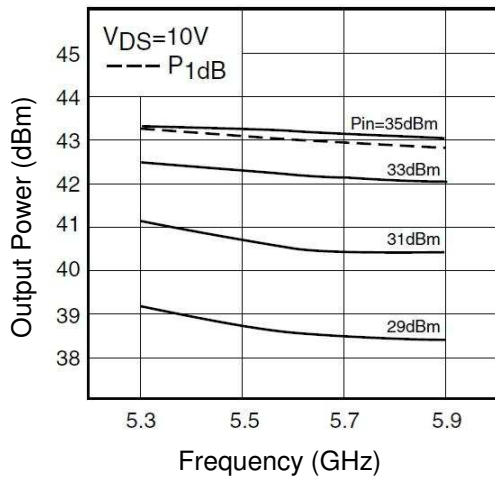

**OUTPUT POWER vs. INPUT POWER**

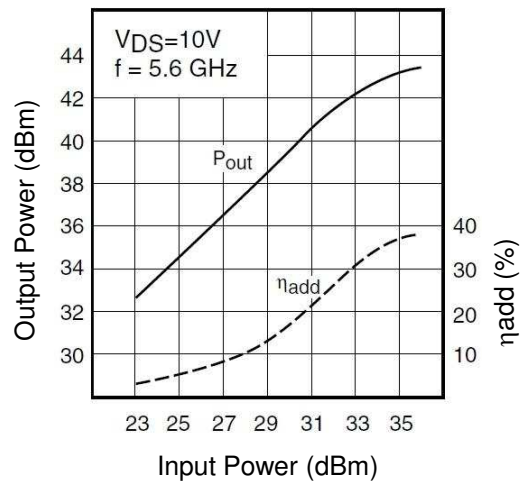

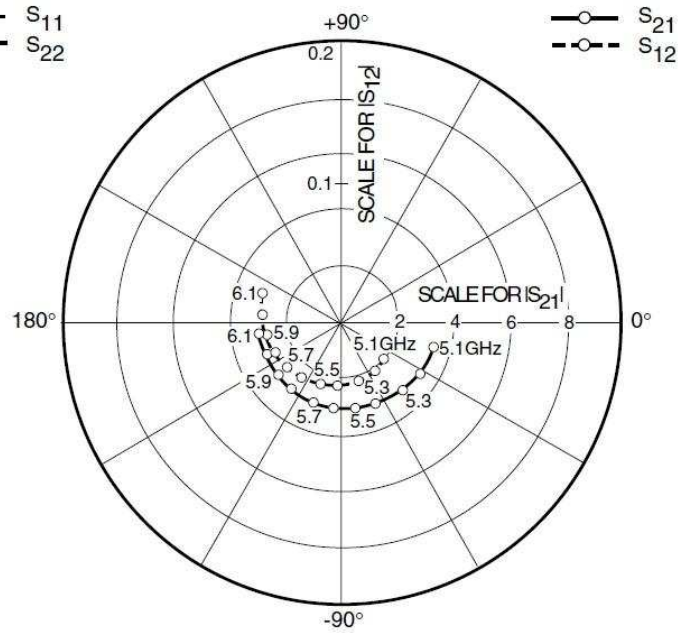
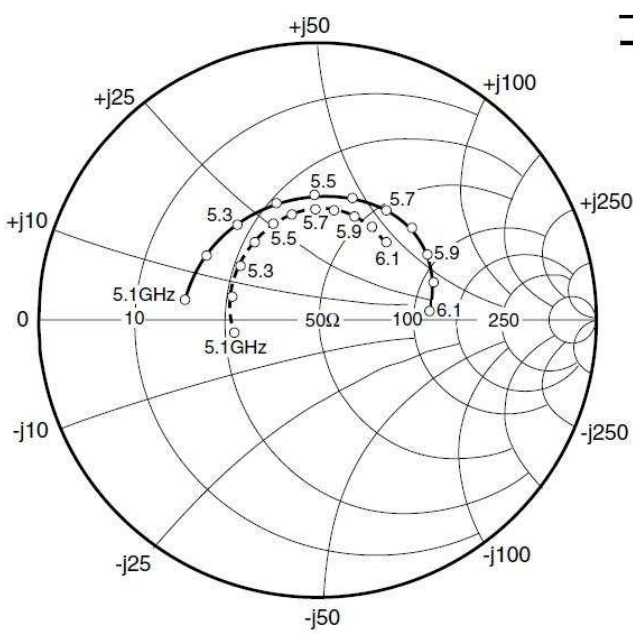

### S-PARAMETERS

$V_{DS} = 10V, I_{DS} = 4800mA$

FREQUENCY (MHz)	S11		S21		S12		S22	
	MAG	ANG	MAG	ANG	MAG	ANG	MAG	ANG
5100	0.482	171.6	3.358	-14.2	0.039	-35.6	0.308	-173.8
5200	0.461	150.2	3.295	-31.5	0.040	-56.5	0.324	164.7
5300	0.449	129.5	3.220	-48.2	0.043	-74.9	0.343	146.1
5400	0.447	109.5	3.136	-64.6	0.045	-93.3	0.364	129.8
5500	0.451	90.9	3.058	-79.9	0.047	-110.9	0.382	116.4
5600	0.459	73.8	2.997	-95.4	0.048	-126.7	0.394	104.3
5700	0.467	58.3	2.954	-110.5	0.051	-141.6	0.398	93.0
5800	0.471	44.1	2.933	-125.8	0.053	-156.6	0.398	82.1
5900	0.463	30.6	2.937	-141.1	0.055	-170.4	0.396	71.4
6000	0.443	17.5	2.973	-156.8	0.058	174.8	0.388	60.8
6100	0.406	3.6	3.040	-173.4	0.061	159.6	0.368	49.7

**Case Style "IK"**  
**Metal-Ceramic Hermetic Package**

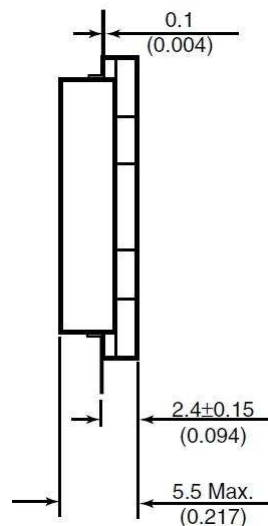
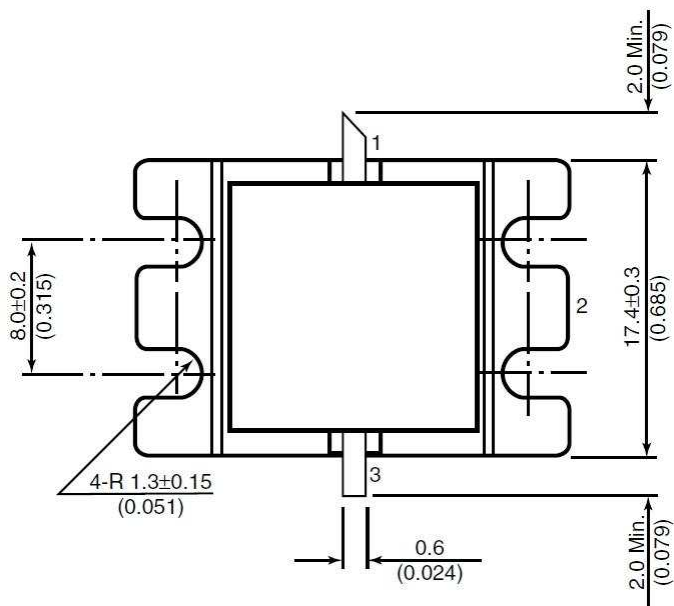

1. Gate
2. Source (Flange)
3. Drain

Unit: mm(inches)



# **FLM5359-18F**

***C-Band Internally Matched FET***

**For further information please contact:**

**<http://global-sei.com/Electro-optic/about/office.html>**

### **CAUTION**

This product contains **gallium arsenide (GaAs)** which can be hazardous to the human body and the environment. For safety, observe the following procedures:

- Do not put these products into the mouth.
- Do not alter the form of this product into a gas, powder, or liquid through burning, crushing, or chemical processing as these by-products are dangerous to the human body if inhaled, ingested, or swallowed.
- Observe government laws and company regulations when discarding this product. This product must be discarded in accordance with methods specified by applicable hazardous waste procedures.