

FEATURES

- High Output Power: $P_{1dB} = 39.5\text{dBm}$ (Typ.)
- High Gain: $G_{1dB} = 11.0\text{dB}$ (Typ.)
- High PAE: $\eta_{add} = 37\%$ (Typ.)
- Low IM3 = $-45\text{dBc}@P_o = 28.5\text{dBm}$
- Broad Band: 3.1 to 3.5GHz
- Impedance Matched $Z_{in}/Z_{out} = 50\text{ohm}$
- Hermetically Sealed Package

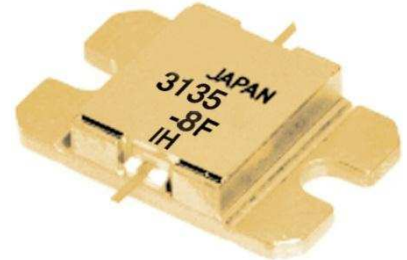

DESCRIPTION

The FLM3135-8F is a power GaAs FET that is internally matched for standard communication bands to provide optimum power and gain in a 50 ohm system.

SEDI's stringent Quality Assurance Program assures the highest reliability and consistent performance.

ABSOLUTE MAXIMUM RATING (Ambient Temperature $T_a=25\text{deg.C}$)

Item	Symbol	Condition	Rating	Unit
Drain-Source Voltage	V_{DS}		15	V
Gate-Source Voltage	V_{GS}		-5	V
Total Power Dissipation	P_T	$T_c = 25\text{deg.C}$	42.8	W
Storage Temperature	T_{stg}		-65 to +175	deg.C
Channel Temperature	T_{ch}		175	deg.C

SEDI recommends the following conditions for the reliable operation of GaAs FETs:

1. The drain-source operating voltage (V_{DS}) should not exceed 10 volts.
2. The forward and reverse gate currents should not exceed 32.0 and -4.4 mA respectively with gate resistance of 100ohm.

ELECTRICAL CHARACTERISTICS (Ambient Temperature $T_a=25\text{deg.C}$)

Item	Symbol	Test Conditions	Limit			Unit
			Min.	Typ.	Max.	
Saturated Drain Current	I_{DSS}	$V_{DS}=5V, V_{GS}=0V$	-	3900	5850	mA
Transconductance	g_m	$V_{DS}=5V, I_{DS}=2200\text{mA}$	-	2000	-	mS
Pinch-off Voltage	V_p	$V_{DS}=5V, I_{DS}=180\text{mA}$	-1.0	-2.0	-3.5	V
Gate Source Breakdown Voltage	V_{GSO}	$I_{GS}=-180\text{uA}$	-5.0	-	-	V
Output Power at 1dB G.C.P.	P_{1dB}	$V_{DS}=10V,$	38.5	39.5	-	dBm
Power Gain at 1dB G.C.P.	G_{1dB}	$I_{DS}=0.55 I_{DSS}$ (Typ.),	10.0	11.0	-	dB
Drain Current	I_{dsr}	$f=3.1$ to 3.5 GHz,	-	2200	2600	mA
Power-added Efficiency	η_{add}	$Z_S=Z_L=50\text{ohm}$	-	37	-	%
Gain Flatness	ΔG		-	-	+/-0.6	dB
3rd Order Intermodulation Distortion	IM_3	$f = 3.5$ GHz, $\Delta f = 10$ MHz 2-Tone Test $P_{out} = 28.5\text{dBm}$ S.C.L.	-42	-45	-	dBc
Thermal Resistance	R_{th}	Channel to Case	-	3.0	3.5	deg.C/W
Channel Temperature Rise	ΔT_{ch}	$10V \times I_{dsr} \times R_{th}$	-	-	80	deg.C

G.C.P.: Gain Compression Point, S.C.L.: Single Carrier Level

CASE STYLE	IB	
ESD	Class 3A	4000V to 8000V
Note : Based on EIAJ ED-4701 C-111A (C=100pF, R=1.5kohm)		
RoHS Compliance	Yes	

POWER DERATING CURVE

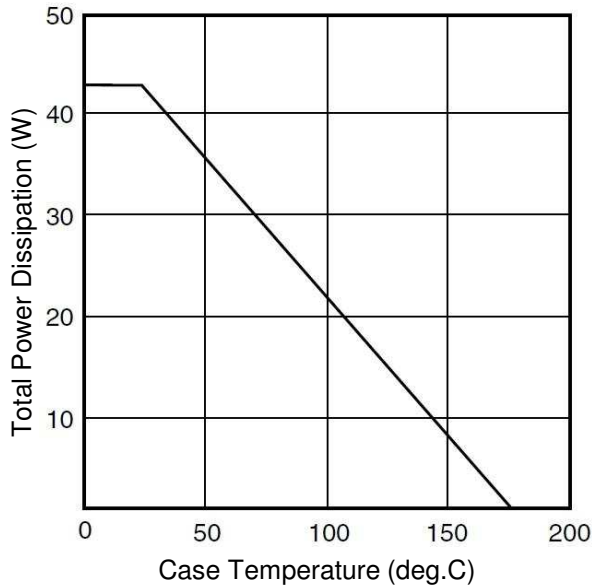

OUTPUT POWER & IM₃ vs. INPUT POWER

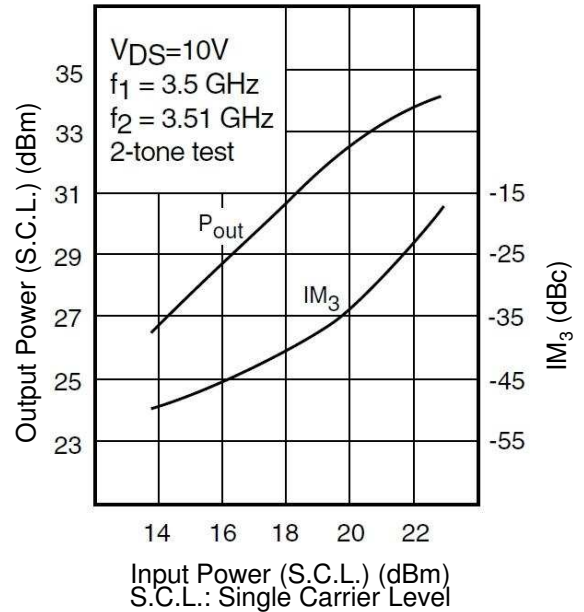

OUTPUT POWER vs. FREQUENCY

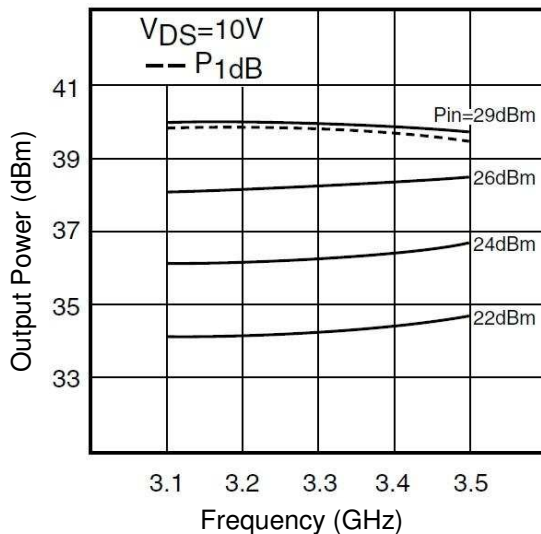

OUTPUT POWER vs. INPUT POWER

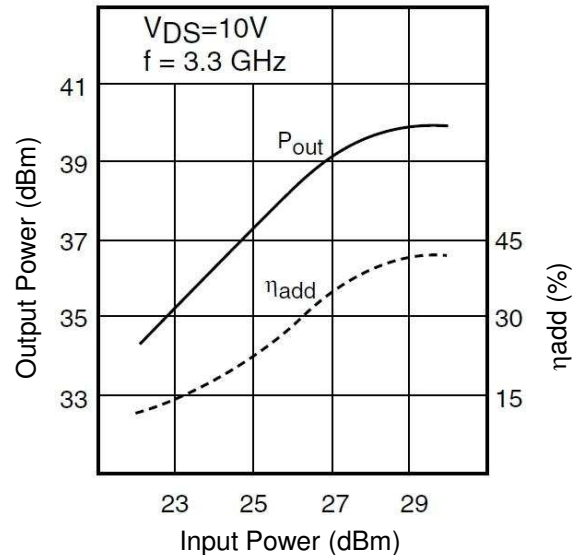

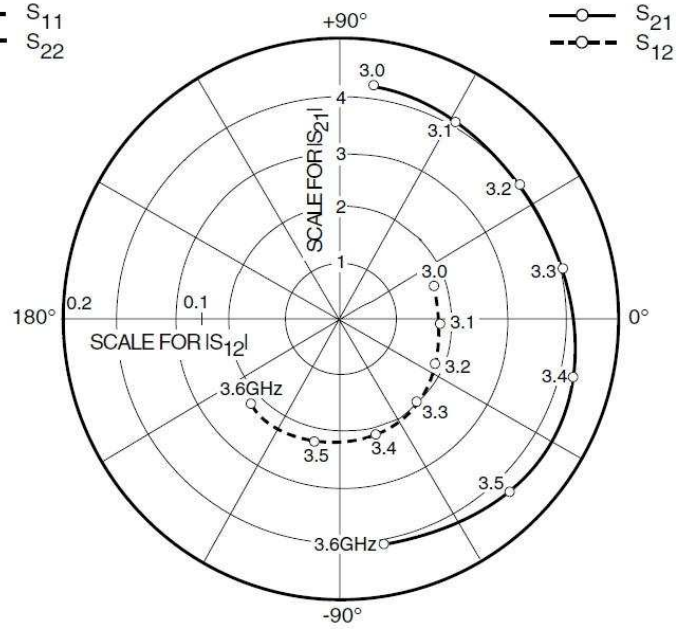
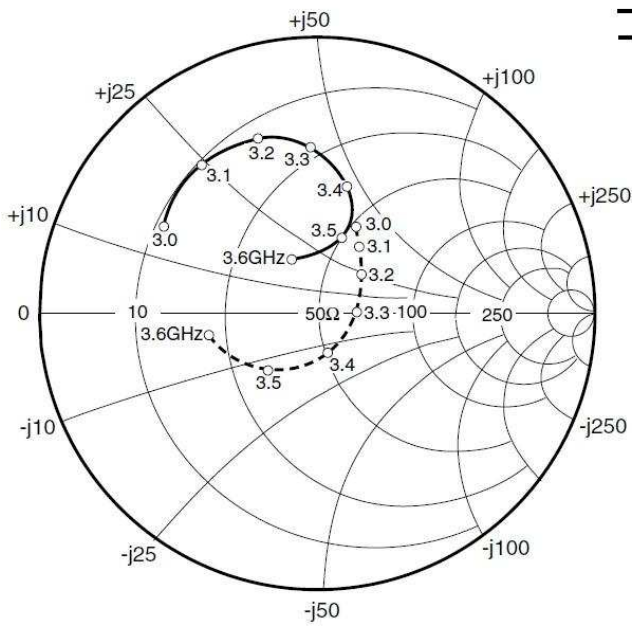

S-PARAMETERS

$V_{DS} = 10V, I_{DS} = 2200mA$

FREQUENCY (MHz)	S11		S21		S12		S22	
	MAG	ANG	MAG	ANG	MAG	ANG	MAG	ANG
3000	0.638	150.7	4.214	81.8	0.071	20.0	0.333	66.1
3100	0.683	128.0	4.042	59.0	0.071	-2.4	0.274	58.9
3200	0.670	109.1	4.005	36.5	0.073	-24.8	0.206	41.6
3300	0.604	92.2	4.105	13.0	0.078	-47.5	0.135	0.1
3400	0.475	77.0	4.264	-13.8	0.085	-73.5	0.155	-78.8
3500	0.284	72.3	4.333	-44.9	0.090	-102.8	0.285	-130.6
3600	0.217	116.0	4.095	-79.5	0.088	-136.1	0.402	-168.7

Case Style "IB"
Metal-Ceramic Hermetic Package

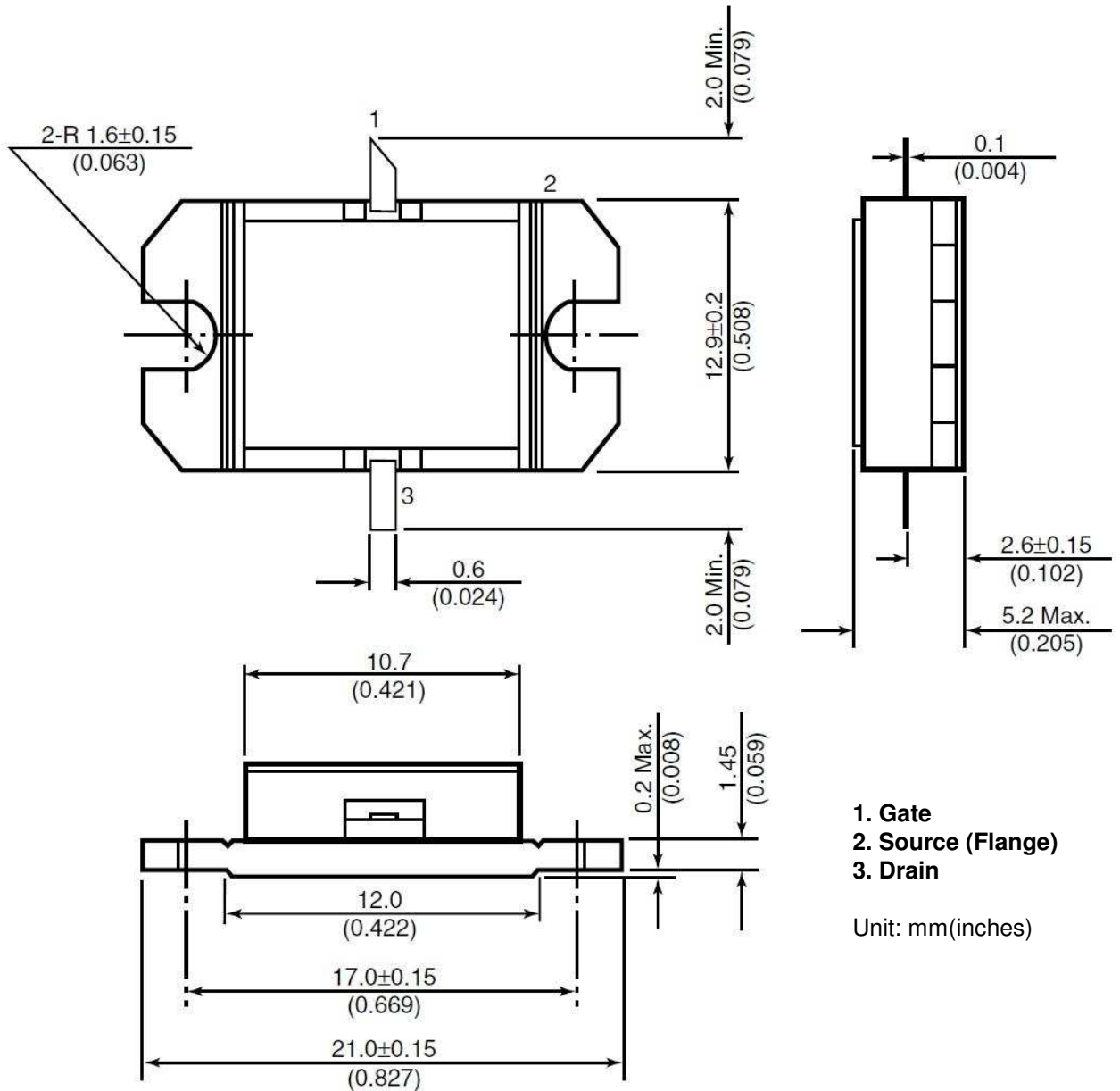



FLM3135-8F

C-Band Internally Matched FET

For further information please contact:

<http://global-sei.com/Electro-optic/about/office.html>

CAUTION

This product contains **gallium arsenide (GaAs)** which can be hazardous to the human body and the environment. For safety, observe the following procedures:

- Do not put these products into the mouth.
- Do not alter the form of this product into a gas, powder, or liquid through burning, crushing, or chemical processing as these by-products are dangerous to the human body if inhaled, ingested, or swallowed.
- Observe government laws and company regulations when discarding this product. This product must be discarded in accordance with methods specified by applicable hazardous waste procedures.