

FMM5715X

60GHz Power Amplifier

FEATURES

- High Output Power; P1dB = 16 dBm (Typ.) @ f = 60 GHz
- High Linear Gain: $|S_{21}| = 17$ dB(Typ) @ f = 60 GHz
- Wide Frequency Band : 57 - 64 GHz
- Impedance Matched $Z_{in}/Z_{out} = 50\Omega$

DESCRIPTION

The FMM5715X is a power amplifier MMIC designed for applications in the 57-64 GHz frequency range. This product is well suited for wireless LAN and point-to-point radio.

Eudyna's stringent Quality Assurance Program assures the highest reliability and consistent performance.

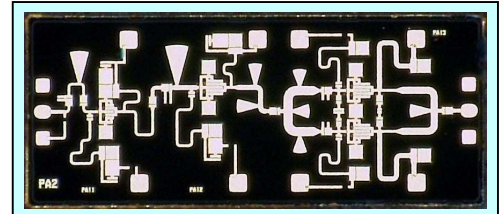

ABSOLUTE MAXIMUM RATING (Case Temperature $T_c=25^\circ\text{C}$)

Item	Symbol	Rating	Unit
DC Input Voltage	VDD	+4	V
DC Input Voltage	VGG	-3	V
Input Power	Pin	3	dBm
Storage Temperature	Tstg	-55 to +125	$^\circ\text{C}$

RECOMMENDED OPERATING CONDITION (Case Temperature $T_c=25^\circ\text{C}$)

Item	Symbol	Condition	Unit
DC Input Voltage	VDD	3	V
Backside Temperature	T_B	-45 to +85	$^\circ\text{C}$

ELECTRICAL CHARACTERISTICS (Case Temperature $T_c=25^\circ\text{C}$)

Item	Symbol	Condition	Limit			Unit
			Min.	Typ.	Max.	
Output Power at 1dB G.C.P.	P1dB	$V_{DD}=3V$	12	16	-	dBm
Linear Gain	$ S_{21} $	$V_{GG}=0V$	14	18	-	dB
Total Drain Current	IDDt	$f = 57\sim 64$ GHz	-	150	-	mA
Input Return Loss	$ S_{11} $		-	8	-	dB
Output Return Loss	$ S_{22} $		-	8	-	dB

These values are representative for CW on chip measurements that are made without bonding wires at the RF ports.

ESD	Class 0	~ 199V
-----	---------	--------

Note : Based on EIAJ ED-4701 C-111A(C=100pF, R=1.5k Ω)

FMM5715X

60GHz Power Amplifier MMIC

Output Power vs. Input Power
Bias Conditions: $V_{DD} = 3V$, $V_{GG} = 0V$

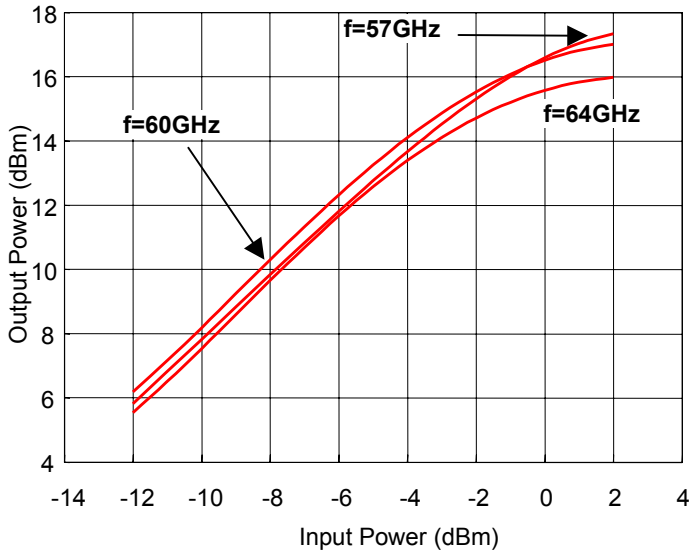

Output Power vs. Frequency
Bias Conditions: $V_{DD} = 3V$, $V_{GG} = 0V$

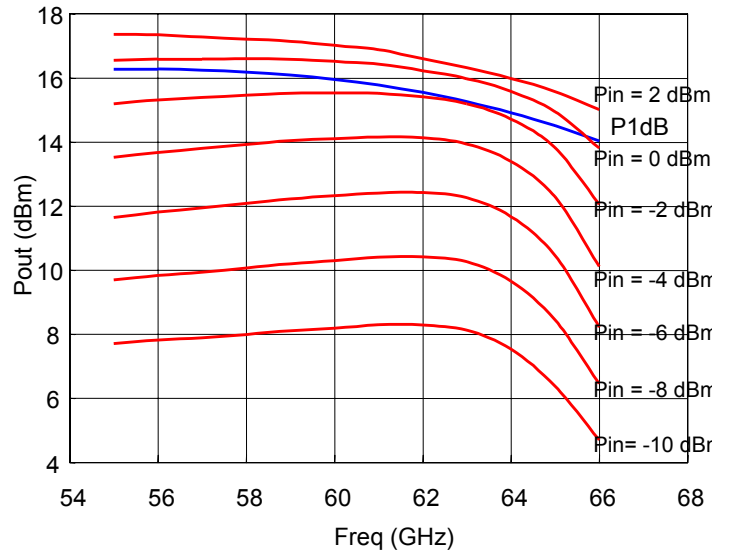

FMM5715X

60GHz Power Amplifier

Linear Gain vs. Frequency

Bias Conditions: $V_{DD} = 3V$, $V_{GG} = 0, -0.1, -0.2 V$

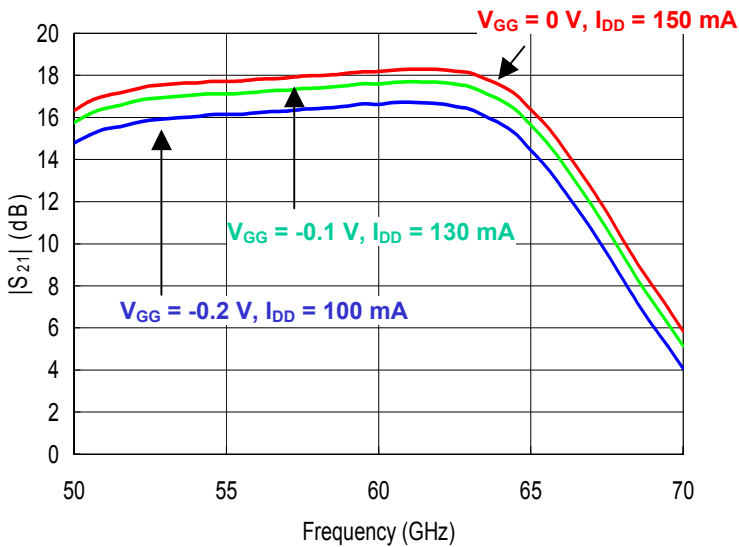

Input Return Loss vs. Frequency

Bias Conditions: $V_{DD} = 3V$, $V_{GG} = 0, -0.1, -0.2 V$

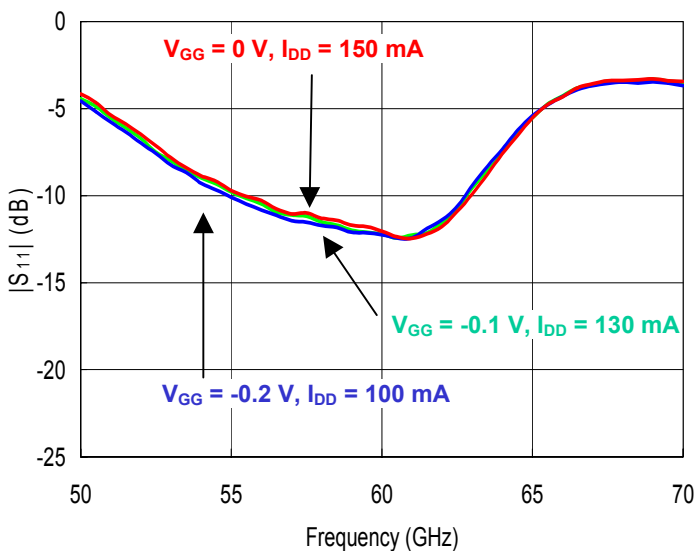

Output Return Loss vs. Frequency

Bias Conditions: $V_{DD} = 3V$, $V_{GG} = 0, -0.1, -0.2 V$

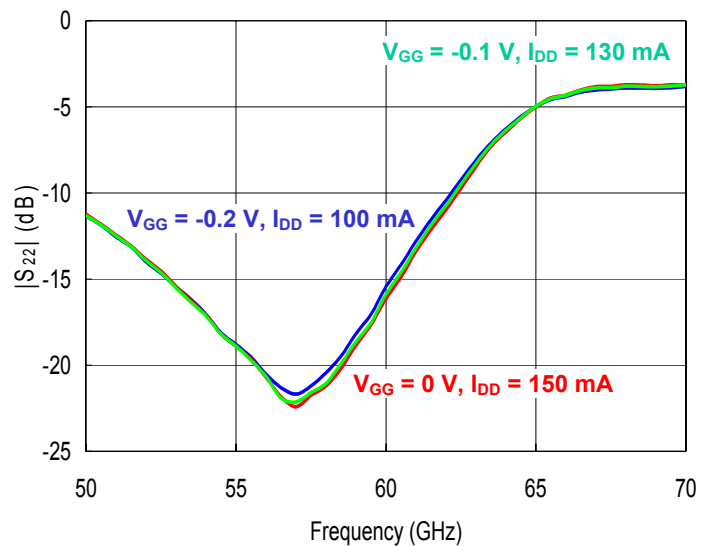

Typical on chip measurements

Eudyna

FMM5715X

60GHz Power Amplifier MMIC

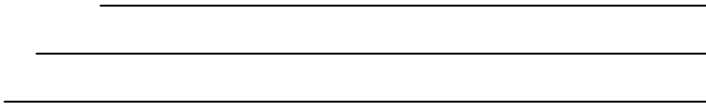

S-PARAMETERS
 $V_{DD} = 3V, V_{GG} = 0V, I_{DD} = 150\text{ mA}$

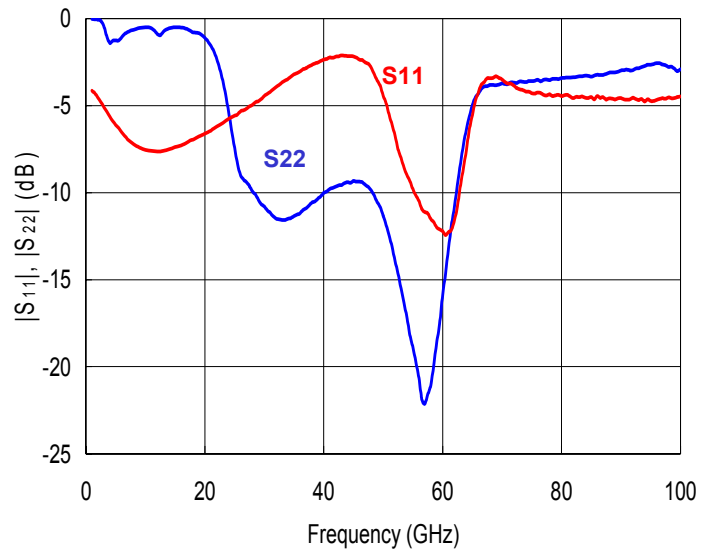
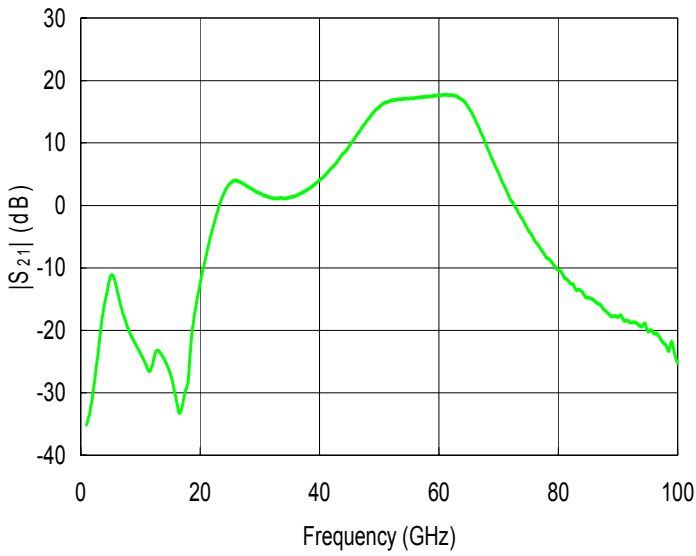

FMM5715X

60GHz Power Amplifier

S-PARAMETERS

VDD = 3V, VGG = 0V, IDD= 150 mA

Freq GHz	S11		S21		S12		S22		Freq GHz	S11		S21		S12		S22	
	MAG	ANG	MAG	ANG	MAG	ANG	MAG	ANG		MAG	ANG	MAG	ANG	MAG	ANG	MAG	ANG
1	0.621	-14.4	0.017	-120.8	0.00014	-72.6	0.997	-11.7	51	0.539	63.0	7.091	-170.0	0.00308	86.8	0.239	126.3
2	0.594	-27.8	0.031	163.7	0.00010	99.9	0.994	-23.8	52	0.474	51.1	7.366	164.1	0.00443	77.6	0.203	119.0
3	0.557	-39.5	0.075	95.4	0.00029	65.9	0.952	-37.4	53	0.406	40.2	7.559	138.8	0.00442	66.8	0.170	112.6
4	0.523	-49.5	0.170	10.6	0.00060	-7.4	0.851	-43.9	54	0.360	29.1	7.621	113.2	0.00520	48.4	0.140	104.9
5	0.496	-57.9	0.290	-71.5	0.00072	-95.9	0.867	-50.7	55	0.327	17.3	7.686	89.6	0.00858	35.4	0.114	94.2
6	0.472	-65.8	0.237	-153.2	0.00037	-155.0	0.884	-57.2	56	0.306	3.3	7.781	64.9	0.00716	3.4	0.092	73.9
7	0.451	-72.3	0.153	164.6	0.00018	155.9	0.913	-65.9	57	0.280	-11.1	7.841	41.7	0.00672	-5.2	0.076	47.1
8	0.436	-77.8	0.110	139.6	0.00012	118.3	0.930	-74.8	58	0.272	-26.2	7.938	17.2	0.00558	-17.1	0.087	14.3
9	0.425	-82.9	0.086	122.5	0.00007	-41.9	0.939	-83.6	59	0.260	-41.3	8.046	-7.1	0.00725	-22.4	0.114	-12.7
10	0.419	-87.5	0.071	109.1	0.00017	-169.4	0.944	-92.3	60	0.250	-52.8	8.118	-32.4	0.00711	-57.6	0.156	-29.2
11	0.416	-91.7	0.056	101.6	0.00015	-161.2	0.938	-101.0	61	0.238	-58.3	8.218	-59.3	0.00784	-84.1	0.214	-39.9
12	0.415	-95.6	0.056	112.7	0.00035	-177.6	0.904	-108.5	62	0.258	-59.3	8.207	-86.5	0.00681	-108.3	0.282	-49.9
13	0.416	-99.0	0.074	90.6	0.00032	36.7	0.916	-113.1	63	0.319	-62.2	8.059	-117.0	0.00671	-137.5	0.377	-60.3
14	0.420	-102.4	0.063	70.8	0.00026	8.6	0.938	-120.7	64	0.417	-70.1	7.527	-148.2	0.00818	-168.1	0.475	-73.7
15	0.426	-105.7	0.048	59.9	0.00017	-4.8	0.945	-128.4	65	0.529	-82.9	6.591	-179.3	0.00671	149.7	0.562	-87.0
16	0.431	-108.9	0.030	63.3	0.00059	-101.0	0.943	-136.1	66	0.608	-99.0	5.437	150.7	0.00734	112.2	0.608	-100.5
17	0.439	-111.8	0.026	110.9	0.00032	-106.7	0.934	-144.1	67	0.662	-114.1	4.272	122.6	0.00429	98.2	0.643	-111.5
18	0.449	-115.0	0.044	150.1	0.00101	-142.6	0.913	-151.4	68	0.678	-127.9	3.252	98.8	0.00629	70.4	0.651	-120.4
19	0.457	-118.3	0.135	142.7	0.00121	147.0	0.909	-159.4	69	0.685	-139.7	2.512	77.2	0.00633	70.3	0.647	-127.7
20	0.465	-120.9	0.254	122.9	0.00060	93.4	0.881	-168.6	70	0.672	-149.3	1.962	58.0	0.00578	61.1	0.652	-133.5
21	0.477	-123.9	0.424	99.8	0.00019	-167.5	0.834	-178.2	71	0.652	-158.2	1.543	39.8	0.00716	52.8	0.652	-138.5
22	0.488	-126.5	0.668	73.6	0.00028	-175.4	0.765	-171.7	72	0.644	-165.6	1.209	23.7	0.00683	33.0	0.656	-143.0
23	0.501	-129.5	0.995	42.7	0.00055	-99.4	0.664	-162.6	73	0.628	-171.6	1.007	7.4	0.00710	25.4	0.659	-147.5
24	0.513	-132.1	1.341	8.8	0.00103	-157.2	0.540	-155.6	74	0.619	-177.6	0.827	-8.1	0.00660	20.9	0.663	-151.0
25	0.525	-135.2	1.607	-27.4	0.00193	168.1	0.424	-154.7	75	0.609	-177.7	0.675	-21.7	0.00819	19.7	0.658	-154.5
26	0.541	-137.9	1.713	-62.7	0.00154	159.5	0.355	-160.3	76	0.605	-172.2	0.562	-34.4	0.00823	14.0	0.665	-158.0
27	0.551	-141.2	1.633	-93.4	0.00174	149.5	0.340	-165.3	77	0.611	-167.2	0.497	-47.0	0.00701	-4.7	0.667	-160.9
28	0.565	-144.1	1.530	-118.8	0.00157	115.7	0.321	-166.5	78	0.608	-161.8	0.420	-60.0	0.01034	-3.8	0.663	-163.9
29	0.578	-146.8	1.431	-141.8	0.00233	105.5	0.304	-168.0	79	0.600	-156.2	0.367	-72.4	0.00994	-20.5	0.673	-166.8
30	0.599	-150.1	1.355	-161.5	0.00132	94.0	0.291	-170.1	80	0.602	-150.6	0.328	-84.8	0.00836	-20.5	0.674	-169.3
31	0.615	-153.4	1.284	-179.5	0.00094	64.0	0.279	-172.7	81	0.599	-145.5	0.288	-96.8	0.00812	-35.3	0.675	-172.2
32	0.636	-157.1	1.241	-164.4	0.00089	83.0	0.268	-174.8	82	0.594	-139.6	0.262	-112.8	0.00798	-44.6	0.676	-174.6
33	0.655	-160.8	1.223	-148.5	0.00098	118.6	0.264	-177.4	83	0.592	-134.8	0.233	-123.3	0.00873	-59.2	0.680	-177.4
34	0.671	-165.2	1.221	-133.4	0.00110	117.8	0.266	-179.6	84	0.591	-129.0	0.214	-136.8	0.01010	-62.9	0.683	-179.3
35	0.693	-169.3	1.249	-118.5	0.00084	100.7	0.269	-178.2	85	0.596	-122.6	0.179	-147.9	0.00993	-79.3	0.679	-178.1
36	0.708	-173.5	1.277	-105.4	0.00137	97.6	0.274	-177.0	86	0.592	-116.9	0.180	-162.7	0.00722	-97.1	0.683	-176.0
37	0.723	-178.4	1.349	91.1	0.00151	101.2	0.282	-176.1	87	0.594	-110.4	0.174	-175.5	0.00510	-117.5	0.688	-174.2
38	0.733	-176.6	1.432	77.2	0.00222	84.0	0.294	-176.7	88	0.588	-103.9	0.157	-168.8	0.00493	-104.3	0.697	-172.0
39	0.752	-171.3	1.544	63.4	0.00159	75.6	0.301	-177.0	89	0.591	97.1	0.149	154.2	0.00488	-92.7	0.699	169.4
40	0.764	-165.7	1.702	49.2	0.00181	85.4	0.313	-178.1	90	0.584	90.6	0.139	137.5	0.00399	-97.3	0.703	167.0
41	0.775	-159.6	1.878	34.0	0.00218	51.3	0.321	-179.6	91	0.593	82.6	0.133	123.7	0.00317	-136.6	0.714	164.4
42	0.782	-153.3	2.114	19.3	0.00182	70.5	0.327	-177.2	92	0.584	75.9	0.123	108.4	0.00200	-111.8	0.712	162.3
43	0.788	-146.0	2.388	3.2	0.00176	47.2	0.331	-174.1	93	0.586	68.4	0.125	91.0	0.00256	-104.6	0.721	159.8
44	0.787	-138.6	2.779	-14.0	0.00248	60.8	0.337	-170.8	94	0.583	59.6	0.113	72.3	0.00254	14.5	0.735	157.6
45	0.785	-130.4	3.178	-32.0	0.00156	37.4	0.341	-166.8	95	0.582	53.5	0.115	52.9	0.00210	-8.0	0.737	154.5
46	0.776	-121.7	3.717	-50.8	0.00149	38.9	0.340	-162.1	96	0.584	45.5	0.104	27.2	0.00369	-8.0	0.743	151.1
47	0.759	-110.9	4.379	-71.9	0.00133	123.7	0.333	-155.8	97	0.582	37.5	0.091	13.9	0.00491	-9.6	0.739	147.0
48	0.730	99.9	5.101	-93.8	0.00158	65.1	0.321	-148.7	98	0.589	30.9	0.078	-13.9	0.00359	-27.7	0.731	144.9
49	0.680	87.9	5.891	-118.2	0.00239	89.0	0.299	-142.1	99	0.587	23.4	0.082	-34.7	0.00488	-22.7	0.715	142.2
50	0.620	75.0	6.554	-143.2	0.00188	97.9	0.275	-134.2	100	0.595	15.9	0.057	-63.6	0.00667	-38.3	0.717	141.6

Typical on chip measurements

FMM5715X

60GHz Power Amplifier MMIC

CHIP OUTLINE

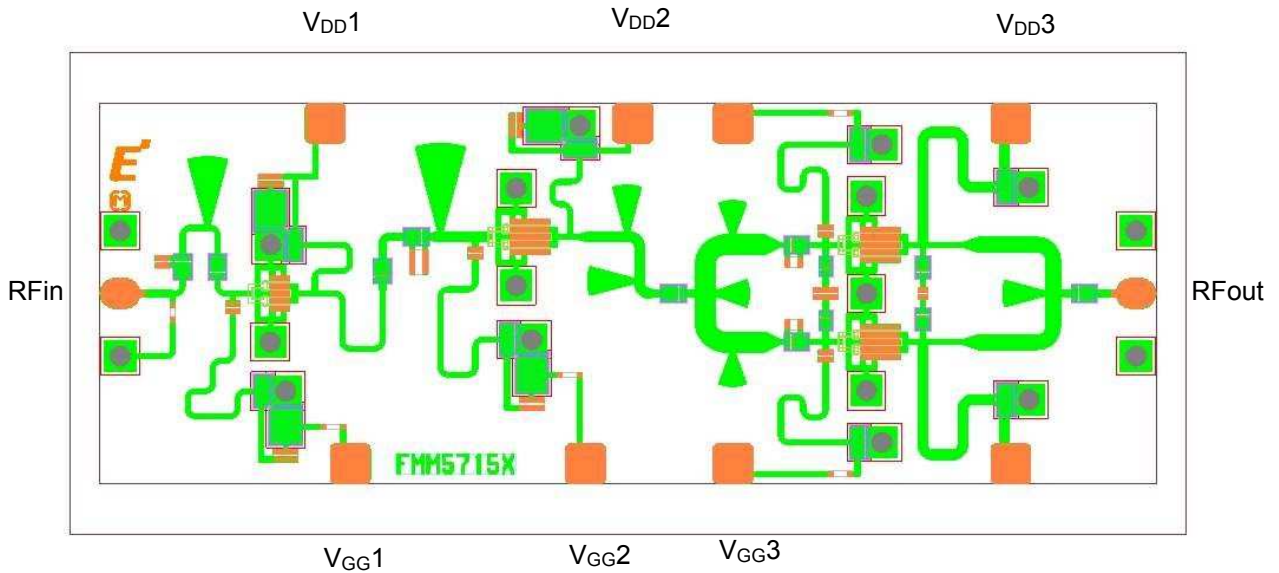

Bonding Pad Locations (Dimension in Micron Meters)

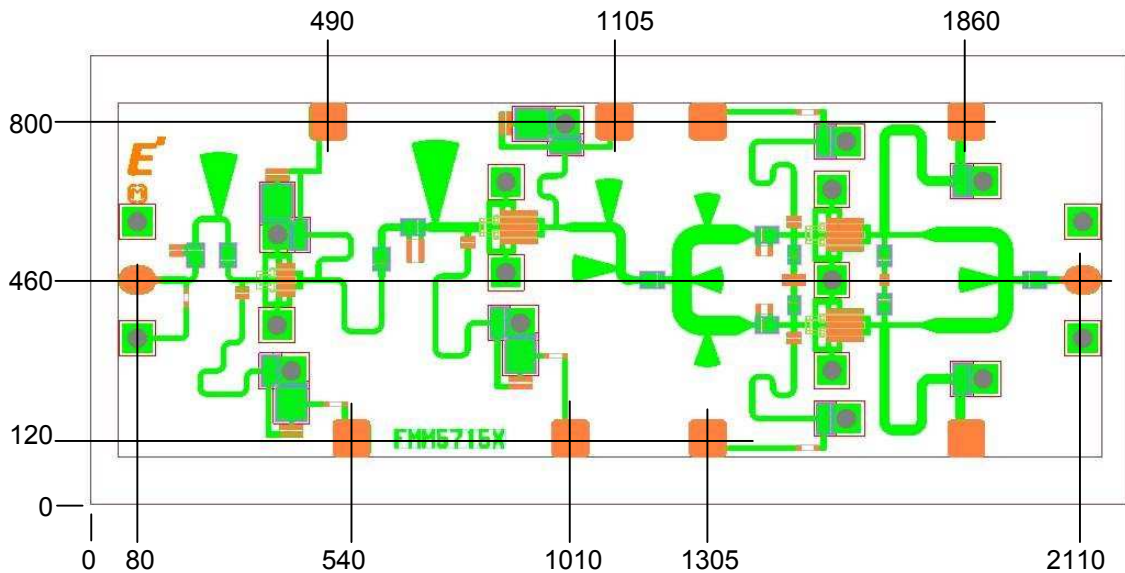

Pad Dimensions
 DC Pads; 80 x 80 μm
 RF Pads; 80 x 60 μm

Unit; μm
 Chip size; 2190 x 920 μm
 Chip Thickness; 70 μm

FMM5715X

60GHz Power Amplifier MMIC

Assembly Diagrams

Recommendation assembly

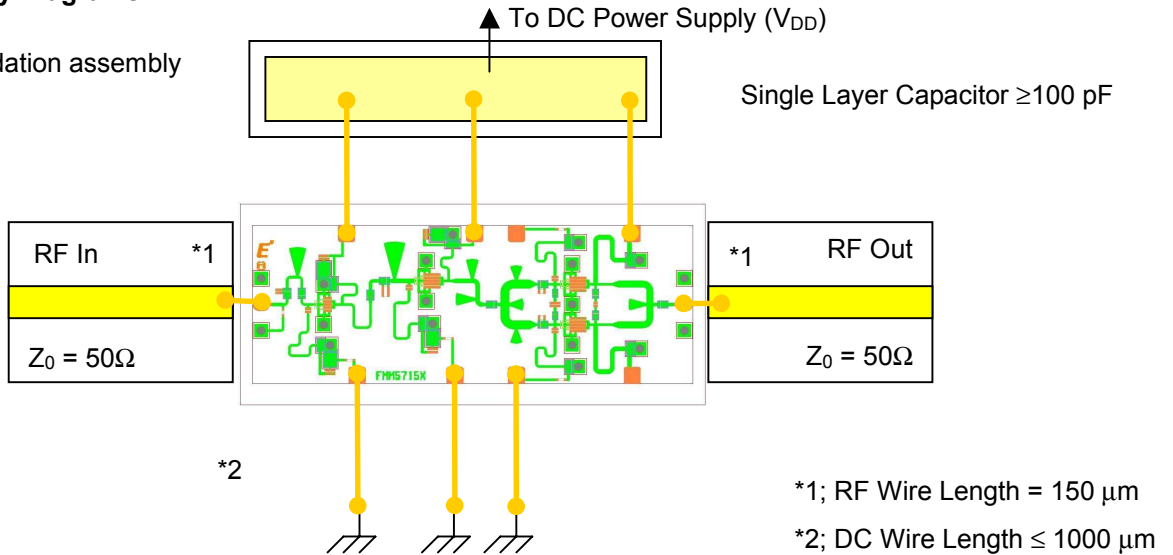

DC Power Supply for a Custom Application

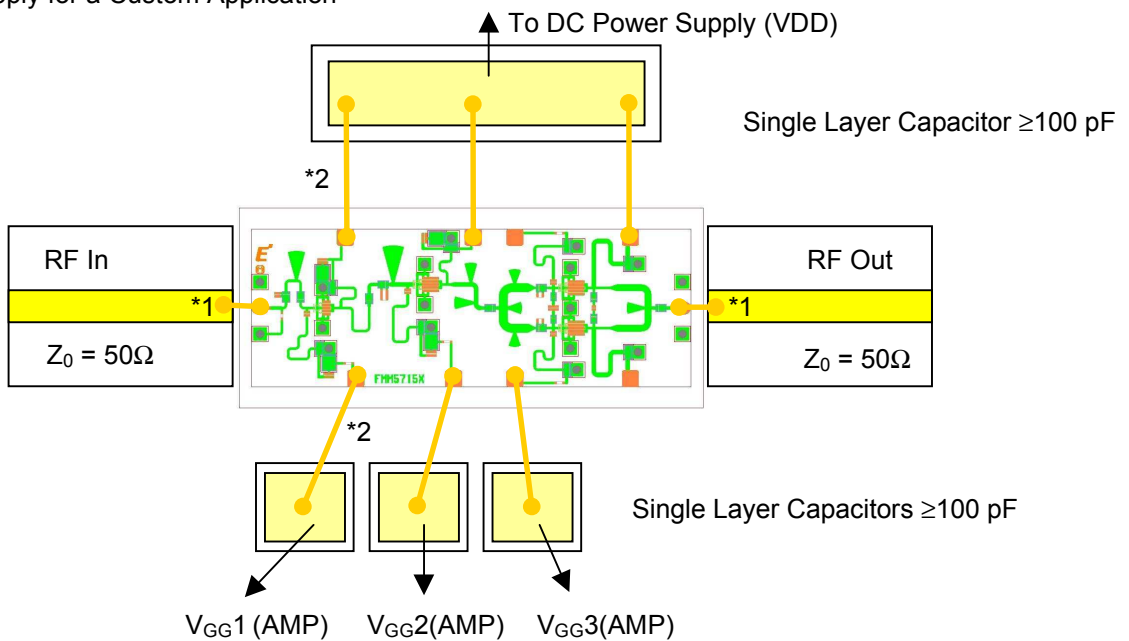

FMM5715X

60GHz Power Amplifier MMIC

MTTF vs. Backside Temperature

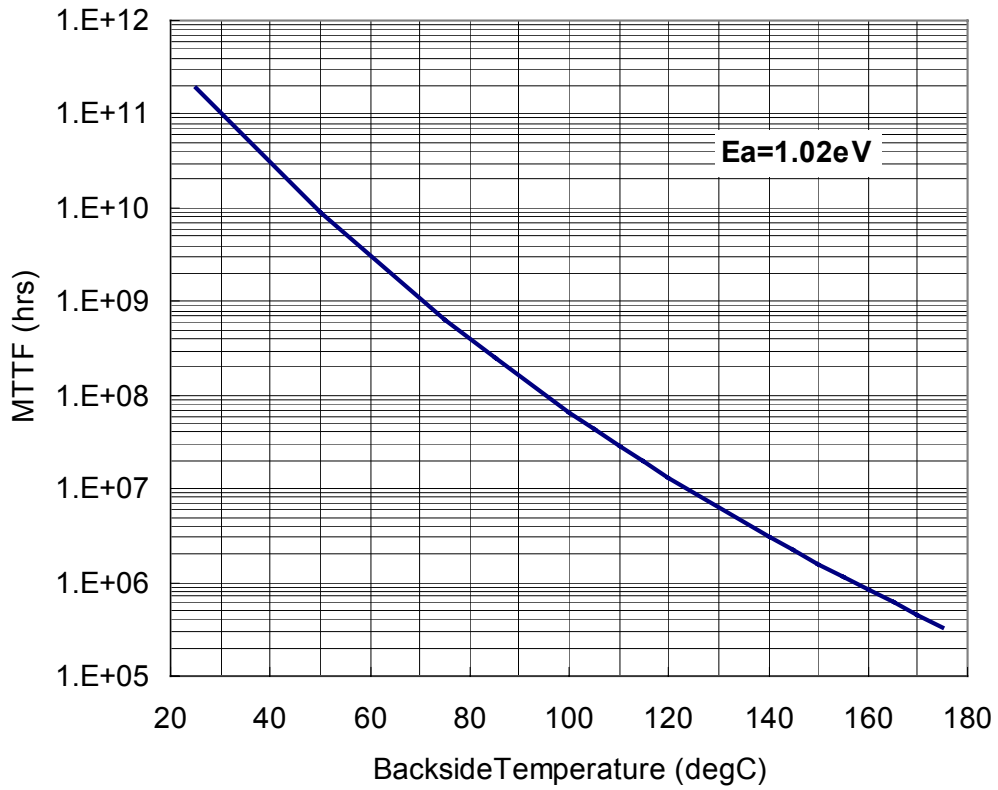

FMM5715X

60GHz Power Amplifier MMIC

DIE ATTACH

- 1) The die-attach station must have accurate temperature control, and an inert forming gas should be used.
- 2) Chips should be kept at room temperature except during die-attach.
- 3) Place package or carrier on the heated stage.
- 4) Lightly grasp the chip edges by the longer side using tweezers.

Die attach conditions

Stage Temperature : 300 to 310 deg.C

Time : less than 15 seconds

AuSn Perform Volume : per next Figure

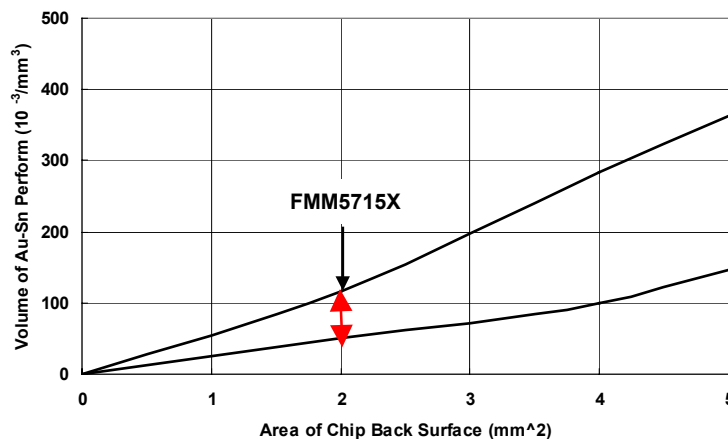

WIRE BONDING

The bonding equipment must be properly grounded. The following or equivalent equipment, tools, materials, and conditions are recommended.

1) Bonding Equipment and Bonding Tool.

Bonding Equipment : West Bond Model 7400 (Manual Bonder)

Bonding Tool : CCOD-1/16-S-437-60-F-2010-MP (Deweyl)

2) Bonding Wire

Material : Hard or Half hard gold

Diameter : 0.7 to 1.0 mil

3) Bonding Conditions

Method : Thermal Compression Bonding with Ultrasonic Power

Tool Force : 0.196 N +/- 0.0196 N

Stage Temperature : 215 deg.C +/- 5 deg.C

Tool Heater : None

Ultrasonic Power Transmitter : West Bond Model 1400

Duration : 150 mS/Bond

Eudyna

FMM5715X

60GHz Power Amplifier MMIC

Eudyna Devices USA Inc.
2355 Zanker Rd.
San Jose, CA 95131-1138, U.S.A.
TEL: (408) 232-9500
FAX: (408) 428-9111
www.us.eudyna.com

Eudyna Devices Europe Ltd.
Network House
Norreys Drive
Maidenhead, Berkshire SL6 4FJ
United Kingdom
TEL: +44 (0) 1628 504800
FAX: +44 (0) 1628 504888

Eudyna Devices Asia Pte. Ltd.
Hong Kong Branch
Suite 1906B, Tower 6, China Hong Kong City
33 Canton Road, Tsimshatsui, Kowloon
Hong Kong
TEL: +852-2377-0227
FAX: +852-2377-3921

Eudyna Devices Inc.
Sales Division
1, Kanai-cho, Sakae-ku
Yokohama, 244-0845, Japan
TEL +81-45-853-8156
FAX +81-45-853-8170

CAUTION

Eudyna Devices Inc. products contain **gallium arsenide (GaAs)** which can be hazardous to the human body and the environment. For safety, observe the following procedures:

- Do not put these products into the mouth.
- Do not alter the form of this product into a gas, powder, or liquid through burning, crushing, or chemical processing as these by-products are dangerous to the human body if inhaled, ingested, or swallowed.
- Observe government laws and company regulations when discarding this product. This product must be discarded in accordance with methods specified by applicable hazardous waste procedures.

Eudyna Devices Inc. reserves the right to change products and specifications without notice. The information does not convey any license under rights of Eudyna Devices Inc. or others.

© 2005 Eudyna Devices USA Inc.
Printed in U.S.A.

Eudyna