

FMM5820X

Ka-Band Power Amplifier MMIC

FEATURES

- High Output Power; Pout = 35.5 dBm (Typ.)
- High Linear Gain; GL = 24 dB(Typ.)
- Frequency Band ; 29.5 - 30.0 GHz
- Impedance Matched Zin/Zout = 50Ω

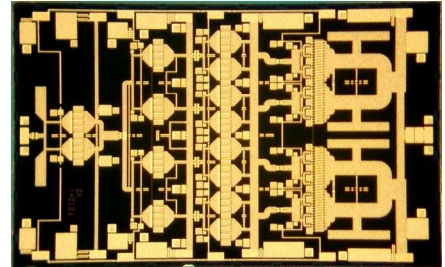

DESCRIPTION

The FMM5820X is a power amplifier MMIC that contains a four-stages amplifier, internally matched, for standard communications band in the 29.5 to 30.0GHz frequency range. This product is well suited for Ka-band V-SAT applications.

Eudyna's stringent Quality Assurance Program assures the highest reliability and consistent performance.

ABSOLUTE MAXIMUM RATING

Item	Symbol	Rating	Unit
Drain-Source Voltage	VDD	10	V
Gate-Source Voltage	VGG	-3	V
Input Power	Pin	21	dBm
Storage Temperature	Tstg	-55 to +125	°C

RECOMMENDED OPERATING CONDITIONS

Item	Symbol	Condition	Unit
Drain-Source Voltage	VDD	≤ 7	V
Input Power	Pin	≤ 18	dBm
Operating Backside Temperature	Top	-40 to +85	°C

This product should be hermetically packaged.

ELECTRICAL CHARACTERISTICS (Ambient Temperature Ta=25°C)

Item	Symbol	Test Conditions	Limits			Unit
			Min.	Typ.	Max.	
Frequency Range	f	VDD=7.0V	29.5	-	30	GHz
Output Power at Pin=15dBm	Pout	IDD(DC)=1500mA typ.	34.5	35.5	-	dBm
Output Power at 1dB G.C.P.	P1dB	Zs=Zl=50ohm	-	35	-	dBm
Linear Gain	GL		20	24	-	dB
Power Added Efficiency at Pin=15dBm	Nadd		-	23	-	%
Drain Current at Pin=15dBm	Iddrf		-	2200	2800	mA
Input Return Loss at Pin=-20dBm	RLin		-	-8	-	dB
Output Return Loss at Pin=-20dBm	RLout		-	-10	-	dB

Note : RF parameter sample size 10ps. Criteria (accept/reject)=(0/1)

G.C.P. : Gain Compression Point

ESD	Class 0	~ 199V
------------	----------------	---------------

Note : Based on EIAJ ED-4701 C-111A(C=100pF, R=1.5kΩ)

FMM5820X

Ka-Band Power Amplifier MMIC

Output Power vs. Frequency

@VDD=7V, IDD(DC)=1500mA

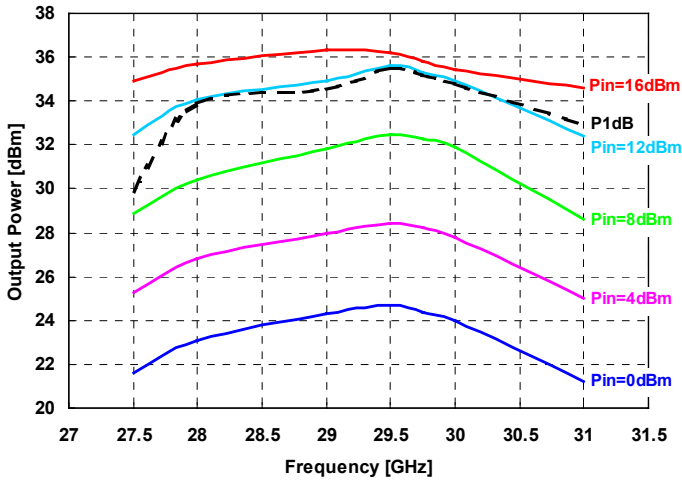

Output Power, Drain Current vs. Input Power

@VDD=7V, IDD(DC)=1500mA

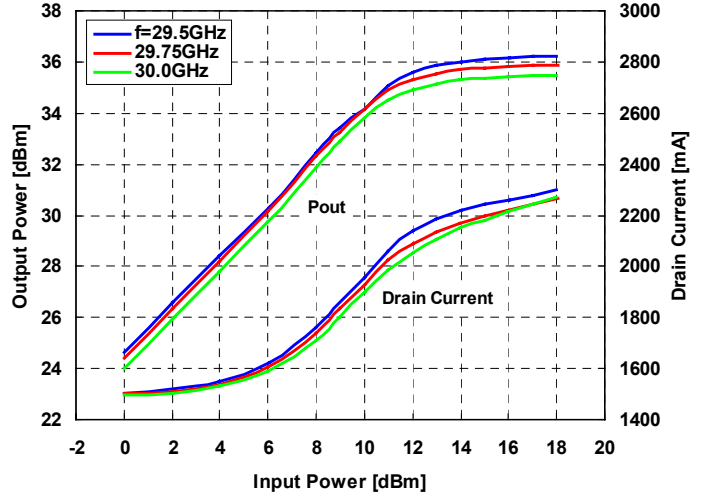

Power Added Efficiency vs. Frequency

@VDD=7V, IDD(DC)=1500mA

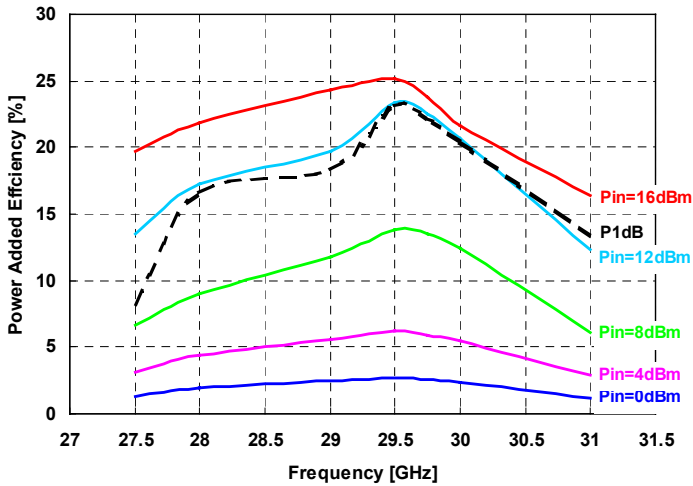

IMD vs. Output Power

@VDD=7V, IDD(DC)=1500mA

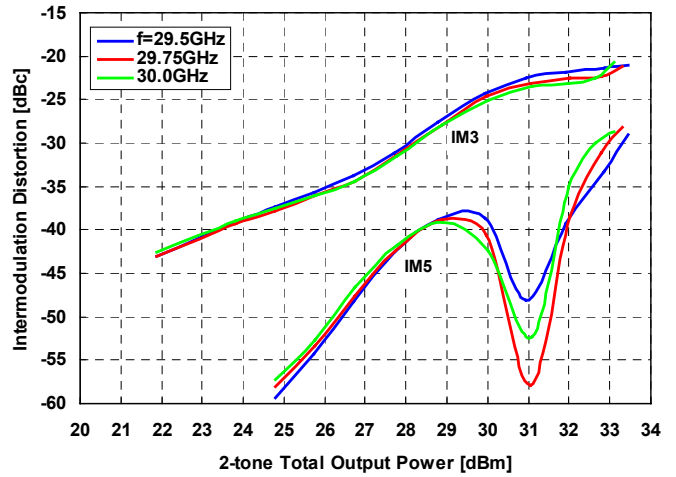

FMM5820X

Ka-Band Power Amplifier MMIC

Output Power, Drain Current vs. Input Power by Drain Voltage

@f=29.5GHz, IDD(DC)=1500mA

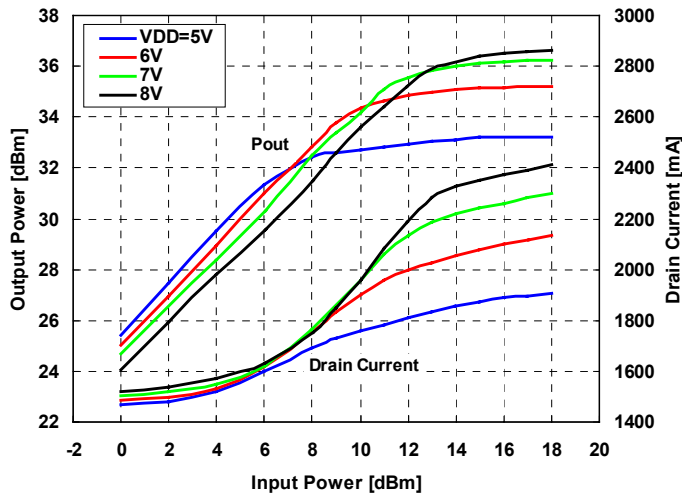

Output Power, Drain Current vs. Input Power by Drain Voltage

@f=29.75GHz, IDD(DC)=1500mA

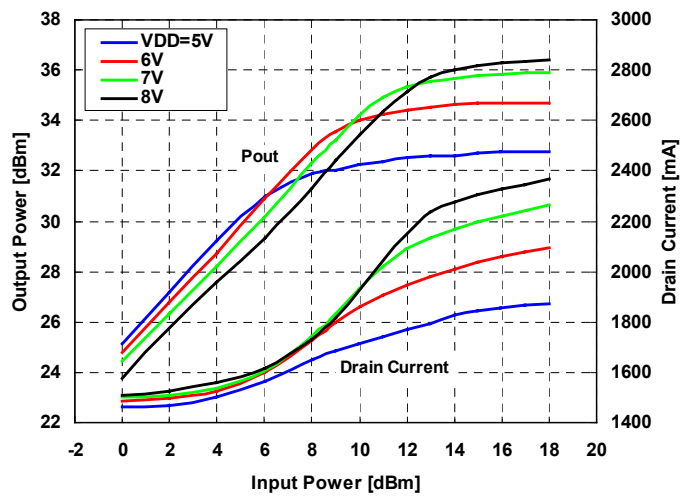

Output Power, Drain Current vs. Input Power by Drain Voltage

@f=30.0GHz, IDD(DC)=1500mA

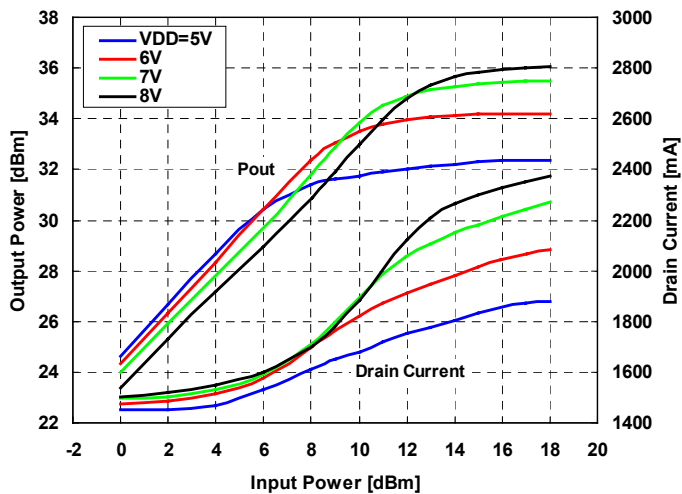

Output Power, Gain vs. Drain Voltage

@IDD(DC)=1500mA

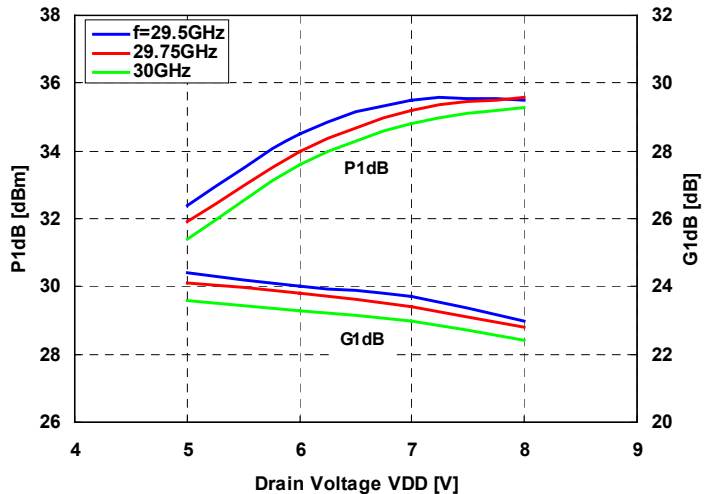

FMM5820X

Ka-Band Power Amplifier MMIC

Output Power, Drain Current vs. Input Power by Drain Current

@f=29.5GHz, VDD=7V

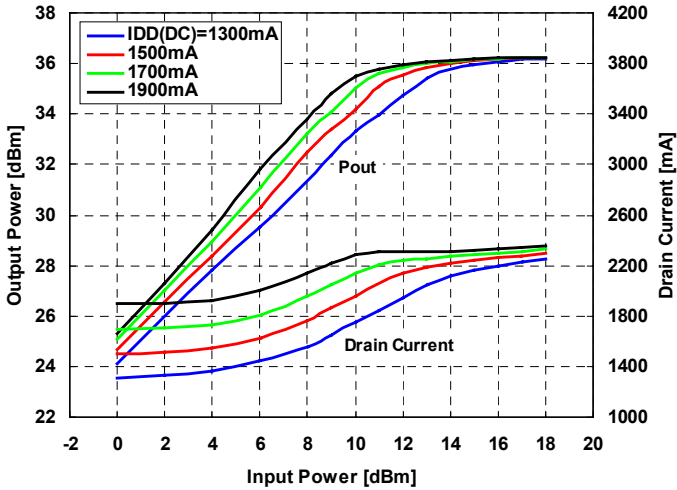

Output Power, Drain Current vs. Input Power by Drain Current

@f=29.75GHz, VDD=7V

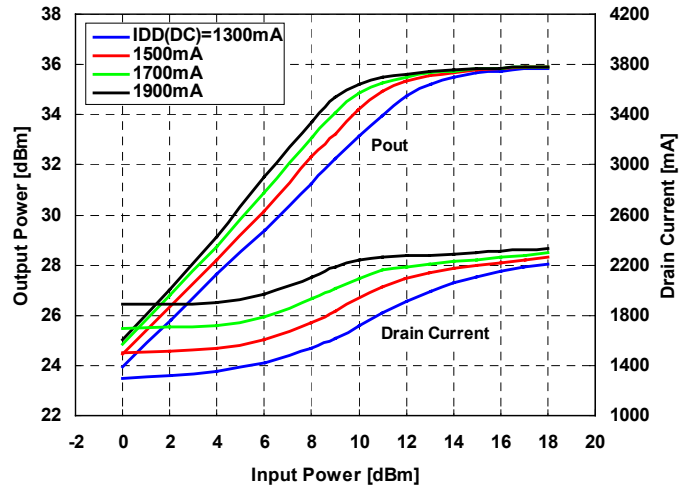

Output Power, Drain Current vs. Input Power by Drain Current

@f=30.0GHz, VDD=7V

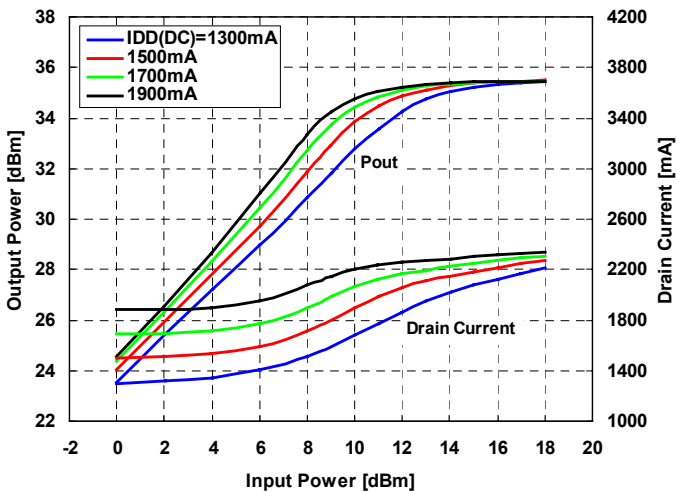

Output Power, Gain vs. Drain Current

@VDD=7V

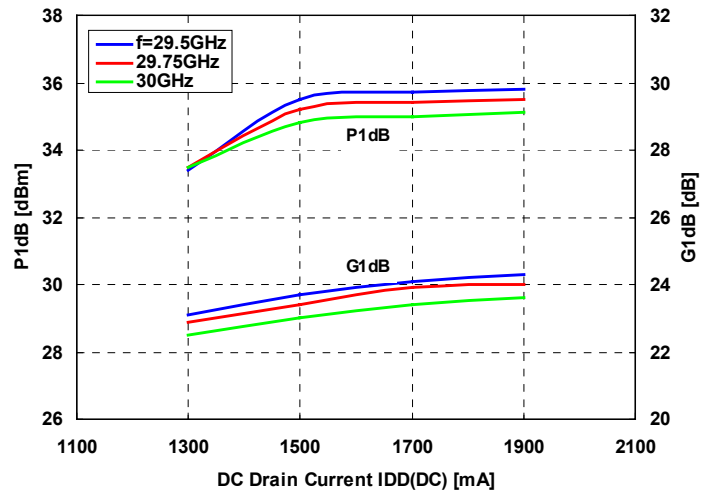

FMM5820X

Ka-Band Power Amplifier MMIC

IMD vs. Output Power by Drain Voltage

@f=29.5GHz, IDD(DC)=1500mA

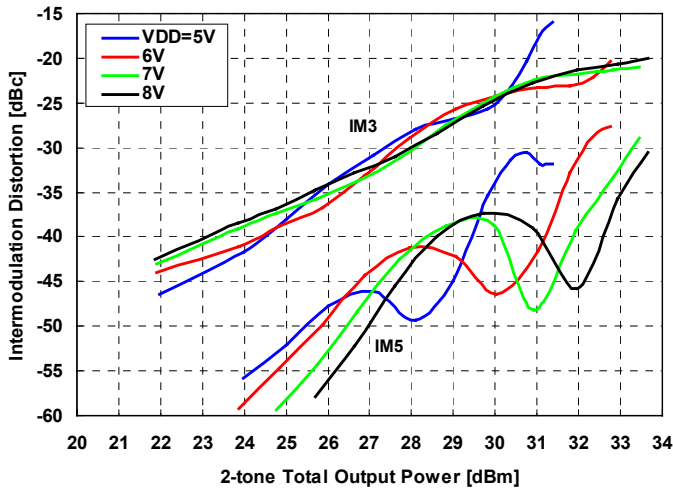

IMD vs. Output Power by Drain Voltage

@f=29.75GHz, IDD(DC)=1500mA

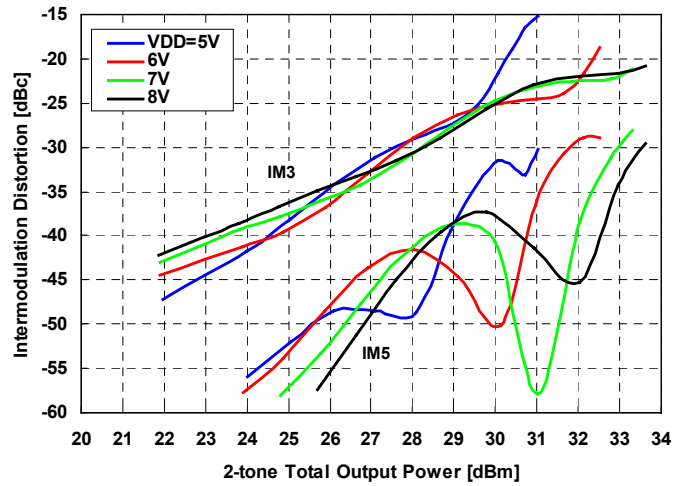

IMD vs. Output Power by Drain Voltage

@f=30.0GHz, IDD(DC)=1500mA

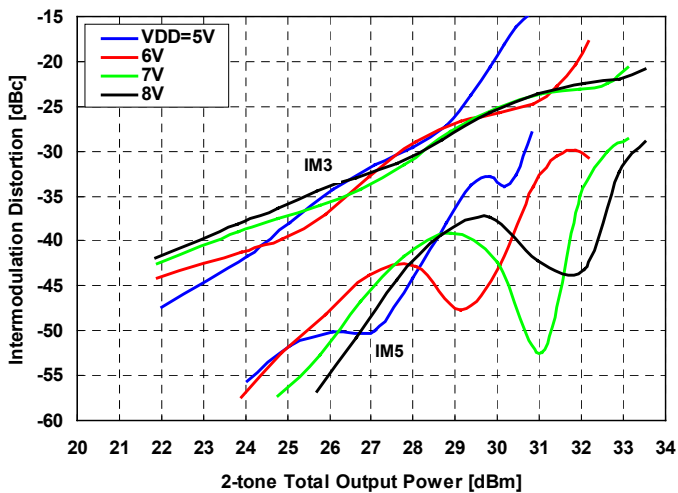

FMM5820X

Ka-Band Power Amplifier MMIC

IMD vs. Output Power
by Drain Current

@f=29.5GHz, VDD=7V

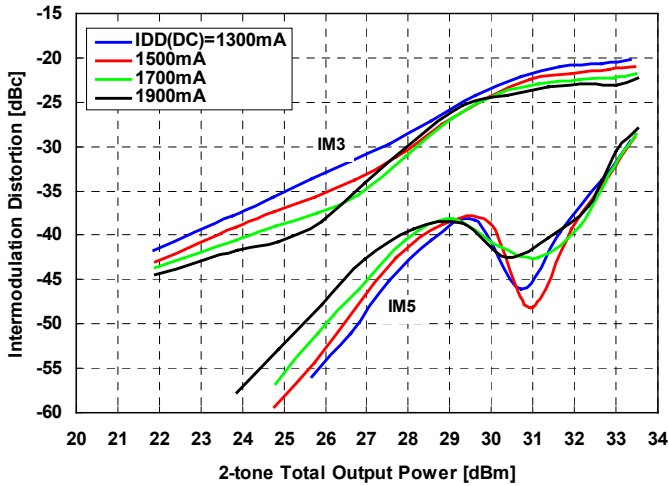

IMD vs. Output Power
by Drain Current

@f=29.75GHz, VDD=7V

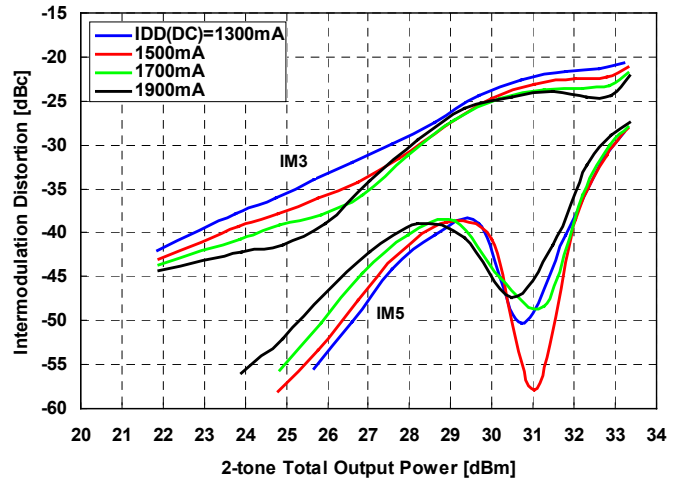

IMD vs. Output Power
by Drain Current

@f=30.0GHz, VDD=7V

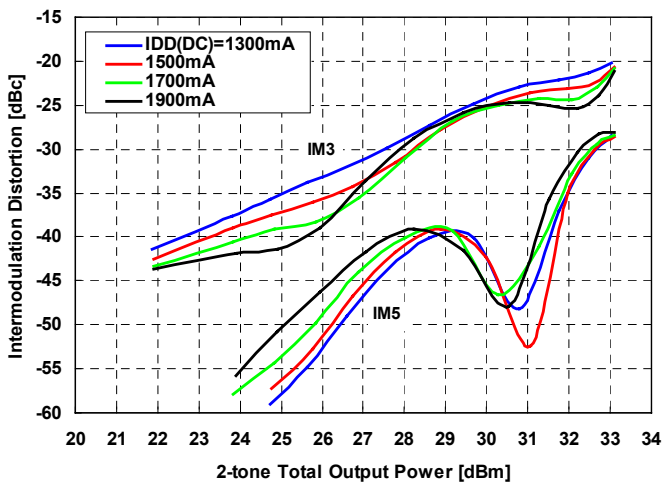

FMM5820X

Ka-Band Power Amplifier MMIC

S-Parameter

@VDD=7V, IDD(DC)=1500mA

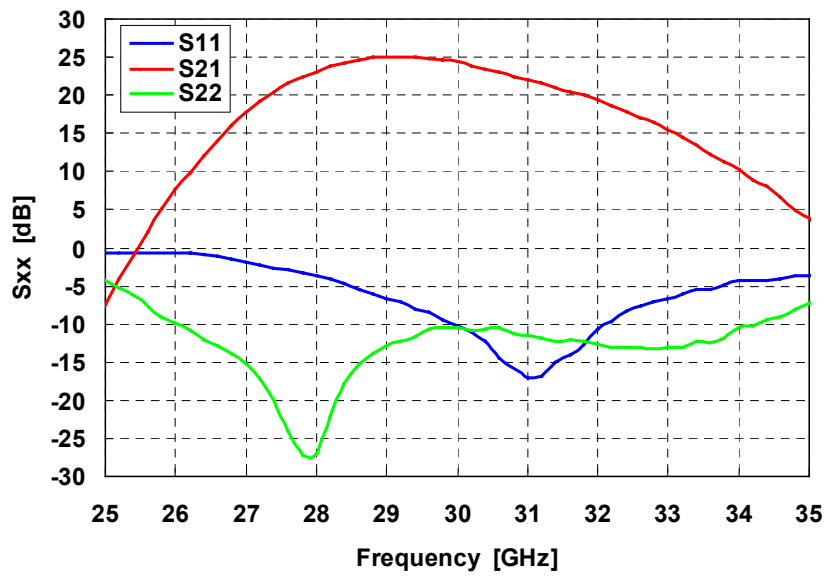
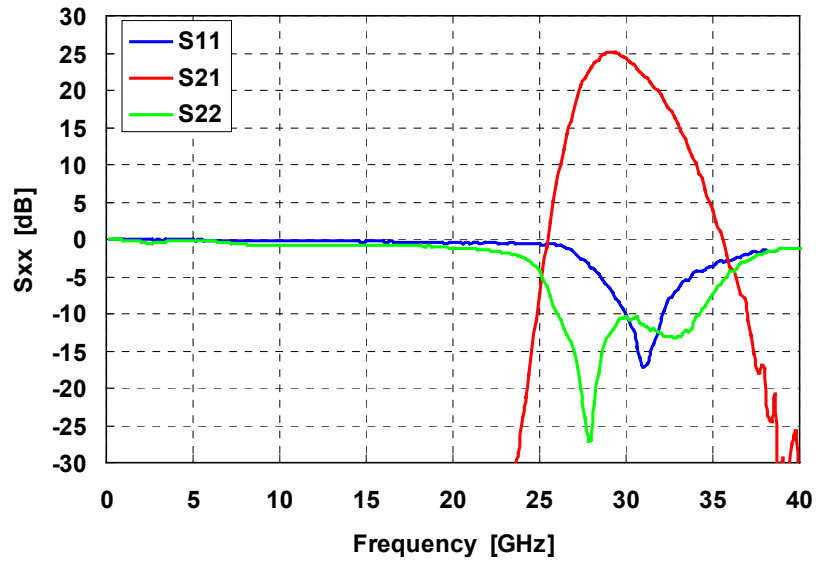

FMM5820X

Ka-Band Power Amplifier MMIC

S-Parameter

VDD=7V, IDD=1500mA

Freq. GHz	S11		S21		S12		S21	
	Mag.	Ang.	Mag.	Ang.	Mag.	Ang.	Mag.	Ang.
1	1.000	-8.84	0.018	36.54	0.001	124.01	0.984	-61.76
2	0.999	-17.66	0.015	143.44	0.000	15.28	0.962	-102.23
3	0.996	-26.37	0.006	-82.94	0.001	-45.86	0.947	-123.54
4	0.996	-34.93	0.002	163.03	0.001	-154.12	0.975	-138.63
5	0.989	-43.05	0.005	-123.49	0.001	-86.15	0.982	-150.35
6	0.987	-50.92	0.003	-96.08	0.003	-85.88	0.972	-159.39
7	0.983	-58.34	0.003	-62.12	0.002	-108.04	0.948	-166.26
8	0.982	-65.47	0.004	-122.20	0.002	-100.39	0.923	-171.16
9	0.982	-72.29	0.004	-67.33	0.003	-87.88	0.909	-174.58
10	0.975	-78.95	0.005	44.42	0.003	-83.82	0.904	-177.70
11	0.976	-85.28	0.005	-44.57	0.003	-101.83	0.908	179.04
12	0.972	-91.04	0.003	-149.21	0.002	-94.18	0.910	175.78
13	0.969	-96.64	0.005	-47.61	0.004	-99.30	0.914	172.35
14	0.975	-101.60	0.006	-77.32	0.006	-94.51	0.914	168.68
15	0.969	-107.14	0.008	52.24	0.005	-82.14	0.914	165.11
16	0.971	-113.35	0.013	-23.85	0.004	-106.79	0.913	161.20
17	0.952	-117.39	0.007	-73.84	0.005	-112.94	0.905	156.88
18	0.955	-122.71	0.020	-95.86	0.005	-65.11	0.903	152.43
19	0.950	-126.63	0.010	-79.59	0.005	-108.92	0.895	147.82
20	0.951	-131.24	0.011	-61.73	0.006	-90.82	0.877	141.79
21	0.937	-135.73	0.008	23.94	0.001	-42.84	0.861	134.93
22	0.949	-140.89	0.005	-29.90	0.001	-170.93	0.839	127.19
23	0.936	-145.71	0.011	43.99	0.006	-70.45	0.803	117.33
24	0.937	-150.80	0.063	-13.13	0.006	-121.97	0.756	102.26
25	0.931	-158.12	0.424	-89.02	0.006	-77.70	0.615	76.43
26	0.914	-167.84	2.398	159.23	0.006	-95.63	0.321	61.83
27	0.804	179.46	7.722	34.35	0.008	-84.40	0.173	47.18
28	0.647	171.95	14.224	-92.06	0.003	-114.00	0.045	-104.08
29	0.468	167.28	17.900	146.98	0.009	-98.96	0.230	-169.24
29.2	0.440	166.82	17.789	123.51	0.011	-99.31	0.245	-175.41
29.4	0.399	167.70	17.899	100.05	0.010	-89.98	0.263	179.90
29.6	0.380	165.35	17.595	79.78	0.016	-68.23	0.291	175.02
29.8	0.337	165.07	16.941	57.74	0.010	-75.84	0.297	166.30
30	0.306	165.99	16.452	36.28	0.007	-146.43	0.300	158.16
30.2	0.282	165.32	15.515	15.36	0.005	-102.11	0.287	153.01
30.4	0.243	166.41	14.801	-4.24	0.008	-93.97	0.293	148.54
30.6	0.188	172.86	14.021	-24.82	0.011	-78.28	0.301	141.72
30.8	0.160	-176.97	13.350	-43.74	0.004	-132.86	0.274	138.48
31	0.140	-160.53	12.746	-63.98	0.009	-84.49	0.267	134.17
32	0.294	-108.35	9.312	-162.05	0.013	-69.16	0.232	107.88
33	0.465	-114.03	5.954	99.72	0.003	-115.53	0.222	66.80
34	0.606	-122.32	3.266	10.14	0.015	-141.11	0.303	6.06
35	0.657	-124.85	1.550	-74.90	0.004	-141.37	0.430	-38.89
36	0.722	-131.46	0.650	-147.68	0.010	-113.61	0.605	-68.64
37	0.799	-137.43	0.290	152.90	0.006	-27.36	0.722	-92.46
38	0.851	-145.04	0.135	119.98	0.008	-102.47	0.808	-111.31
39	0.859	-147.72	0.034	-45.15	0.001	-29.35	0.861	-126.53
40	0.869	-151.54	0.011	2.17	0.009	-123.73	0.866	-138.77

FMM5820X

Ka-Band Power Amplifier MMIC

ΔT_{ch} vs. Drain Voltage
(Reference)

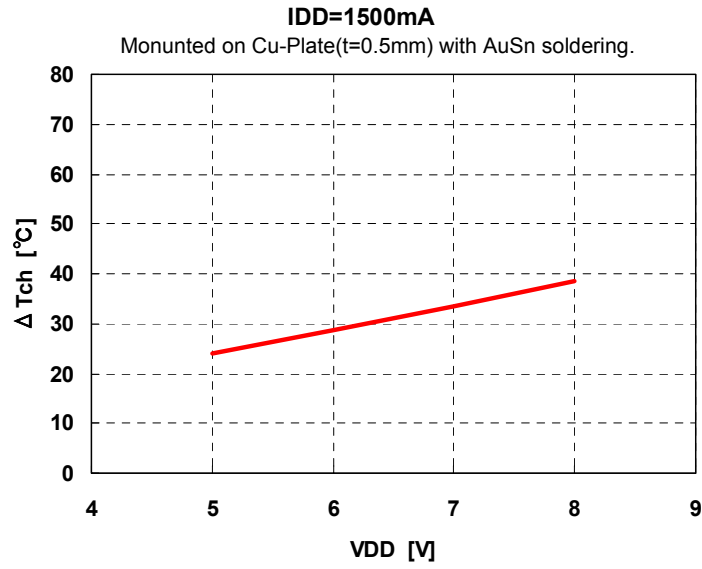

MTTF vs. T_{ch}

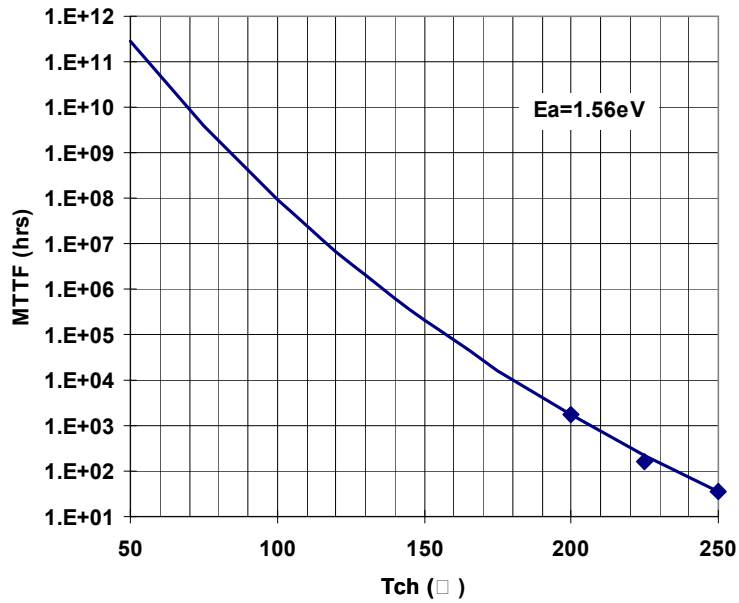

FMM5820X

Ka-Band Power Amplifier MMIC

■ Chip Outline and Bonding Pad Locations (Dimension in Micro-Meters)

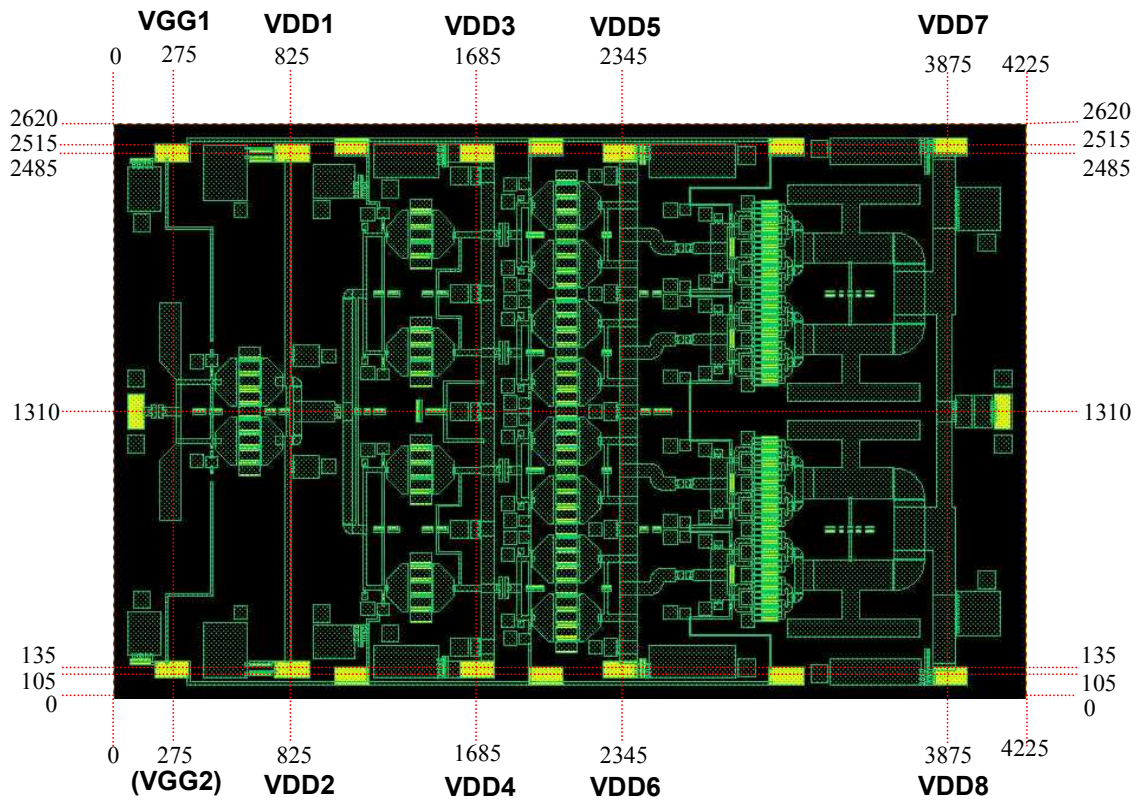

Chip Size : 4225±30um x 2620±30um

Chip Thickness : 60±20um

Bonding Pad Size : 160um x 80um

NOTE: Gate voltage is required from either or both bonding pad(VGG1 or/and VGG2).

FMM5820X

Ka-Band Power Amplifier MMIC

■ Assembly Diagrams

Recommended assembly

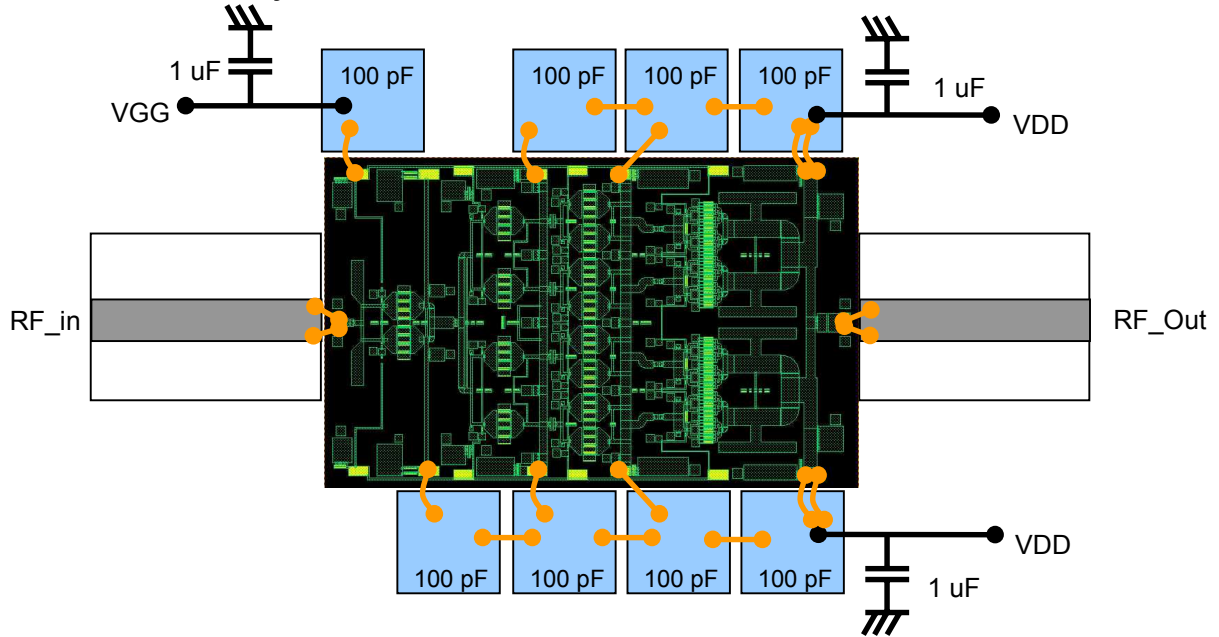

“Copper” is the recommended material for the package or carrier.

FMM5820X

Ka-Band Power Amplifier MMIC

■ DIE ATTACH

- 1) The die-attach station must have accurate temperature control, and an inert forming gas should be used.
- 2) Chips should be kept at room temperature except during die-attach.
- 3) Place package or carrier on the heated stage.
- 4) Lightly grasp the chip edges by the longer side using tweezers.

Die attach conditions

Stage Temperature: 300 to 310 °C

Time : less than 15 seconds

AuSn Preform Volume : per next Figure

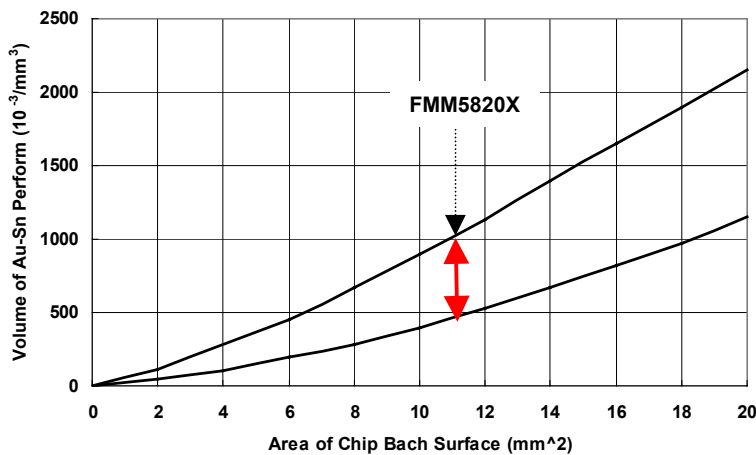

■ WIRE BONDING

The bonding equipment must be properly grounded. The following or equivalent equipment, tools, materials, and conditions are recommended.

1) Bonding Equipment and Bonding Tool.

Bonding Equipment : West Bond Model 7400 (Manual Bonder)

Bonding Tool : CCOD-1/16-S-437-60-F-2010-MP (Deweyl)

2) Bonding Wire

Material : Hard or Half hard gold

Diameter : 0.7 to 1.0 mil

3) Bonding Conditions

Method : Thermal Compression Bonding with Ultrasonic Power

Tool Force : 0.196 N ± 0.0196 N

Stage Temperature : 215 °C ± 5 °C

Tool Heater : None

Ultrasonic Power Transmitter : West Bond Model 1400

Duration : 150 mS/Bond

FMM5820X
Ka-Band Power Amplifier MMIC

For further information please contact :

Eudyna Devices USA Inc.
2355 Zanker Rd.
San Jose, CA 95131-1138, U.S.A.
TEL: +1 408 232-9500
FAX: +1 408 428-9111

Eudyna Devices Europe Ltd.
Network House
Norreys Drive
Maidenhead, Berkshire SL6 4FJ
United Kingdom
TEL: +44 (0) 1628 504800
FAX: +44 (0) 1628 504888

Eudyna Devices International Srl
Via Teglio 8/2 - 20158
Milano, Italy
TEL: +39-02-8738-1695

Eudyna Devices Asia Pte. Ltd.
Hong Kong Branch
Suite 1906B, Tower 6, China Hong Kong City
33 Canton Road, Tsimshatsui, Kowloon
Hong Kong
TEL: +852-2377-0227
FAX: +852-2377-3921

Eudyna Devices Inc.
1000 Kamisukiahara, showa-cho
Nakakomagun, Yamanashi
409-3883, Japan
(Kokubo Industrial Park)
TEL +81-55-275-4411
FAX +81-55-275-9461

Sales Division
1, Kanai-cho, Sakae-ku
Yokohama, 244-0845, Japan
TEL +81-45-853-8156
FAX +81-45-853-8170

CAUTION

Eudyna Devices Inc. products contain **gallium arsenide (GaAs)** which can be hazardous to the human body and the environment. For safety, observe the following procedures:

- Do not put these products into the mouth.
- Do not alter the form of this product into a gas, powder, or liquid through burning, crushing, or chemical processing as these by-products are dangerous to the human body if inhaled, ingested, or swallowed.
- Observe government laws and company regulations when discarding this product. This product must be discarded in accordance with methods specified by applicable hazardous waste procedures.

Eudyna Devices Inc. reserves the right to change products and specifications without notice. The information does not convey any license under rights of Eudyna Devices Inc. or others.

© 2006 Eudyna Devices Inc.

Eudyna