

EMM5079X

X / Ku-Band Power Amplifier MMIC

FEATURES

- Output Power; P1dB = 25 dBm (Typ.)
- High Gain; GL = 23.5 dB(Typ.)
- Wide Frequency Band ; 10.0 – 15.4 GHz
- Impedance Matched Zin/Zout = 50Ω

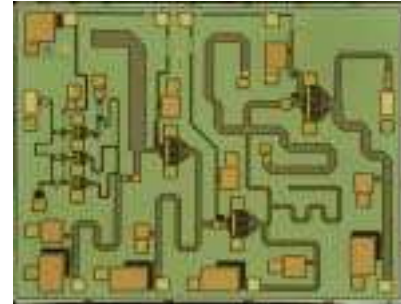

DESCRIPTION

The EMM5079X is a wide band power amplifier MMIC that contains a four stage amplifier, internally matched, for standard communications band in 10.0 to 15.4GHz frequency range. This product is well suited for point-to-point radio and VSAT applications.

Eudyna's stringent Quality Assurance Program assures the highest reliability and consistent performance.

ABSOLUTE MAXIMUM RATING

Item	Symbol	Rating	Unit
Drain-Source Voltage	V _{DD}	10	V
Gate-Source Voltage	V _{GG}	-3	V
Input Power	P _{in}	16	dBm
Storage Temperature	T _{stg}	-55 to +125	°C

RECOMMENDED OPERATING CONDITIONS

Item	Symbol	Condition	Unit
Drain-Source Voltage	V _{DD}	=< 6	V
Input Power	P _{in}	=< 6	dBm
Operating Backside Temperature	Top	-40 to +85	°C

This Product should be hermetically packaged.

ELECTRICAL CHARACTERISTICS (Ambient Temperature Ta=25°C)

Item	Symbol	Test Conditions	Limits			Unit
			Min.	Typ.	Max.	
Frequency Range	f	VDD=6.0V	10.0	-	15.4	GHz
Output Power at 1dB G.C.P.	P _{1dB}	IDD(DC)=350mA typ.	23	25	-	dBm
Power Gain at 1dB G.C.P.	G _{1dB}	Zs=Zl=50ohm	19.0	22.5	-	dB
Power Added Efficiency at 1dB G.C.P.	η _{add}	*1 : f=10.0~11.7GHz	-	15	-	%
Third Order Intermodulation ³	IM3 ³	*2 : f=11.7~15.4GHz	-25 ⁻¹	-32 ⁻¹	-	dBc
		*3 : df=10MHz	-30 ⁺²	-40 ⁺²	-	
Drain Current at 1dB G.C.P.	IDD	2-Tone Test	-	350	500	mA
Input Return Loss at Pin=-20dBm	RL _{in}	Po=15dBm S.C.L.	-	8	-	dB
Output Return Loss at Pin=-20dBm	RL _{out}		-	10	-	dB

G.C.P. : Gain Compression Point

S.C.L. : Single Carrier Level

ESD	Class 0	~ 250V
-----	---------	--------

Note : Based on JEDEC JESD22-A114C

RoHs Compliance	Yes
-----------------	-----

EMM5079X

X / Ku-band Power Amplifier MMIC

Output Power vs. Frequency

@VDD=6V, IDD(DC)=350mA

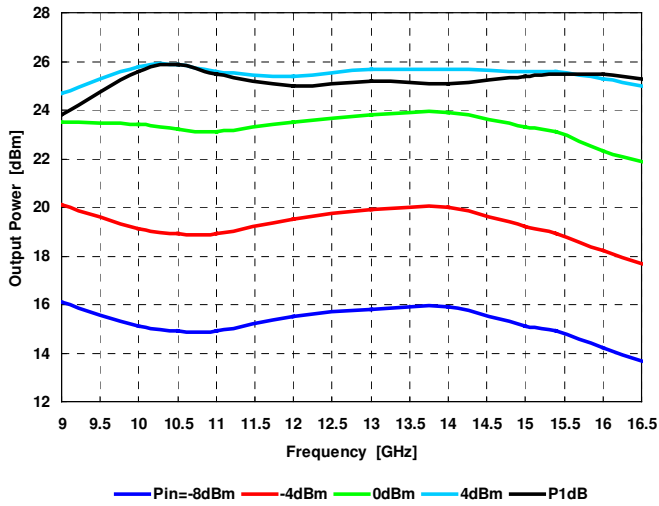

Output Power, Drain Current vs. Input Power

@VDD=6V, IDD(DC)=350mA

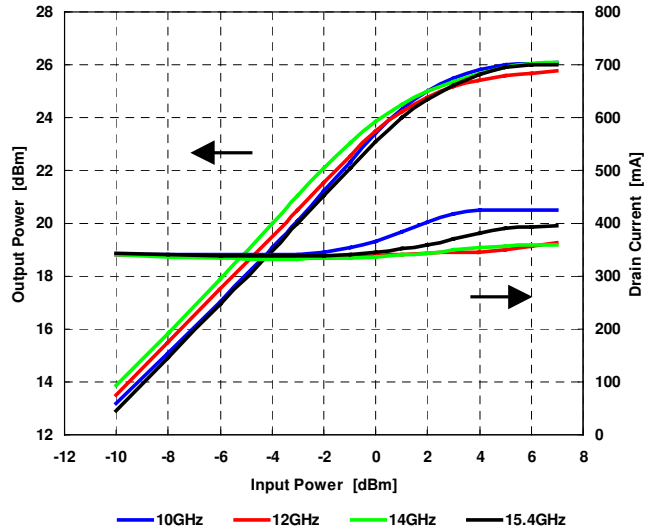

Power Added Efficiency vs. Frequency

@VDD=6V, IDD(DC)=350mA

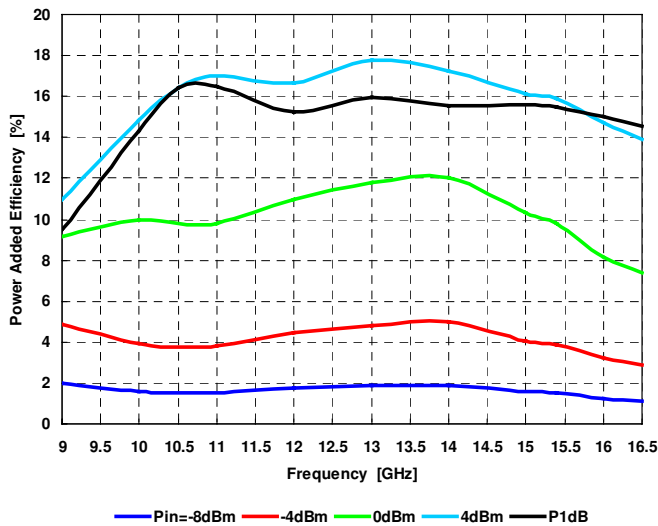

IMD vs. Output Power

@VDD=6V, IDD(DC)=350mA

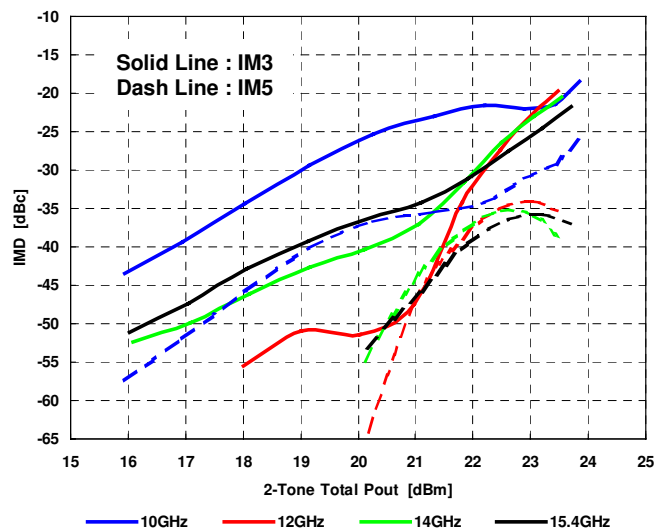

EMM5079X

X / Ku-Band Power Amplifier MMIC

IM3 vs. Frequency

@VDD=6V, IDD(DC)=350mA, @Po=15dBm S.C.L.

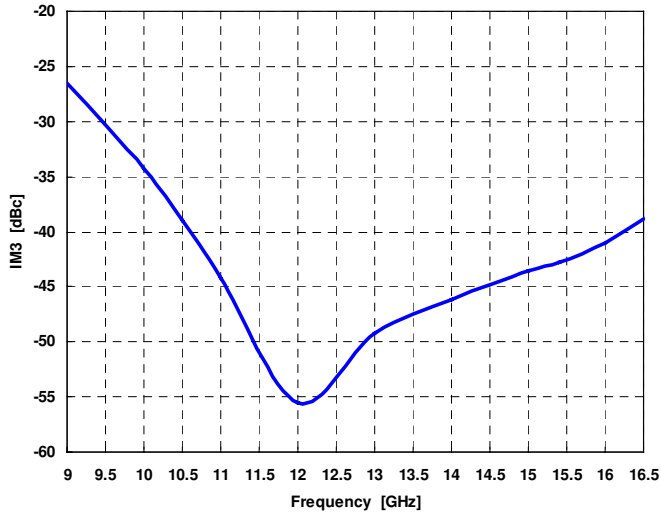

P1dB, G1dB vs. Frequency by Drain Voltage

@IDD(DC)=350mA

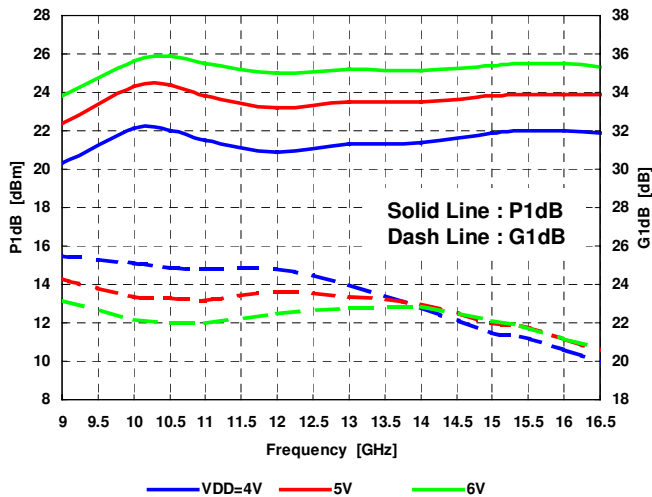

P1dB, G1dB vs. Frequency by Drain Current

@VDD=6V

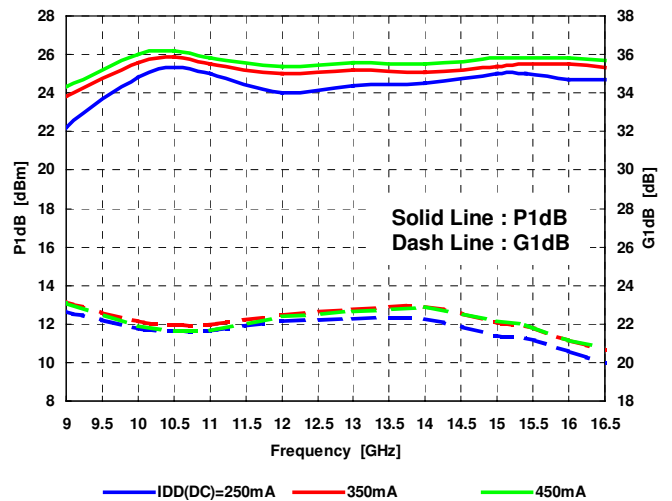

EMM5079X

X / Ku-band Power Amplifier MMIC

Output Power, Drain Current vs. Input Power by Drain Voltage

@f=10GHz, IDD(DC)=350mA

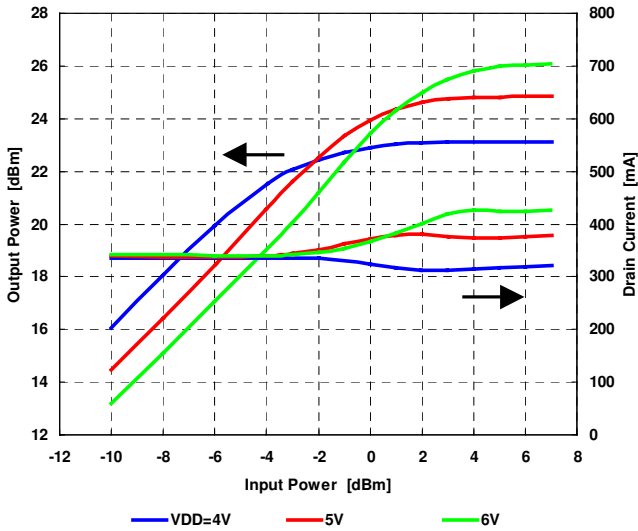

Output Power, Drain Current vs. Input Power by Drain Voltage

@f=12GHz, IDD(DC)=350mA

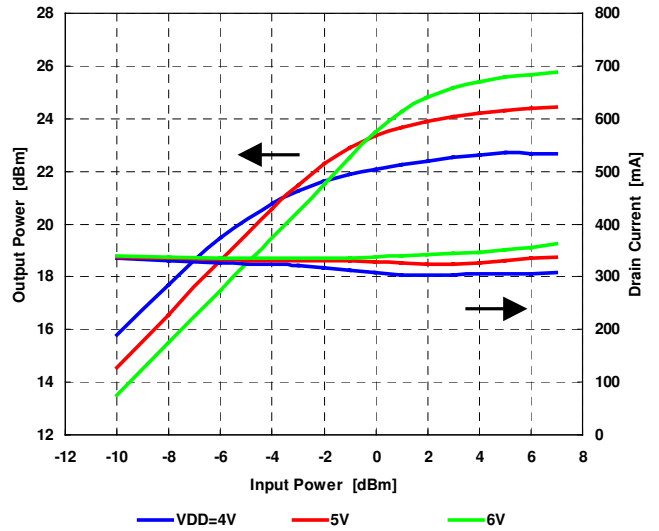

Output Power, Drain Current vs. Input Power by Drain Voltage

@f=14GHz, IDD(DC)=350mA

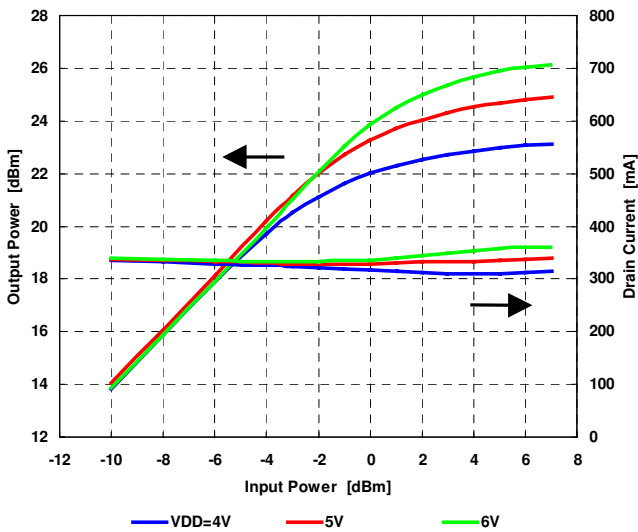

Output Power, Drain Current vs. Input Power by Drain Voltage

@f=15.4GHz, IDD(DC)=350mA

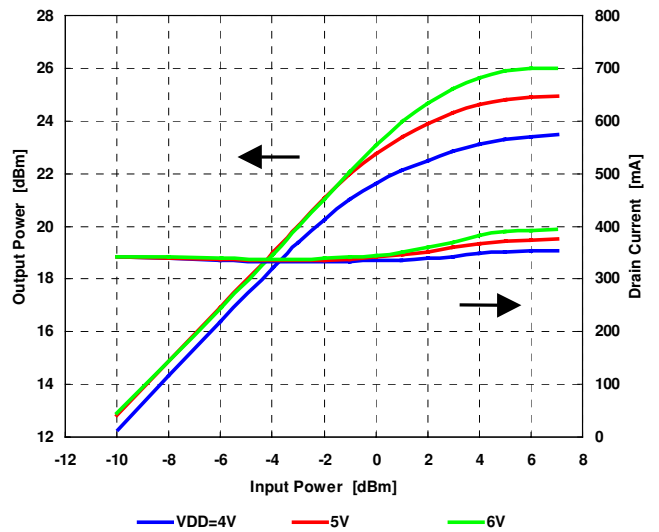

EMM5079X

X / Ku-Band Power Amplifier MMIC

Output Power, Drain Current vs. Input Power by Drain Current

@f=10GHz, VDD=6V

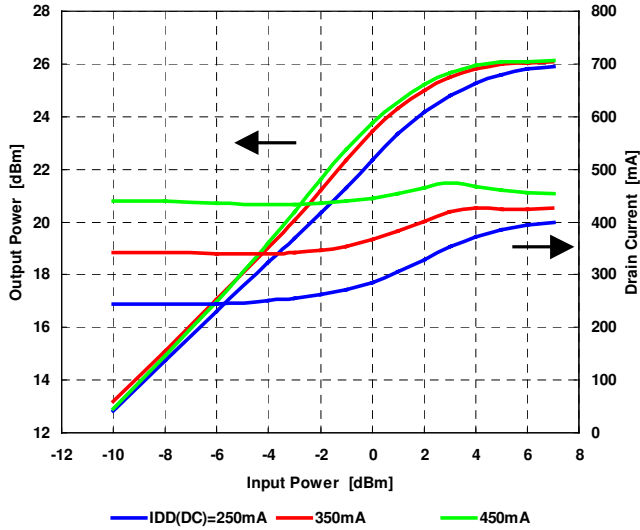

Output Power, Drain Current vs. Input Power by Drain Current

@f=12GHz, VDD=6V

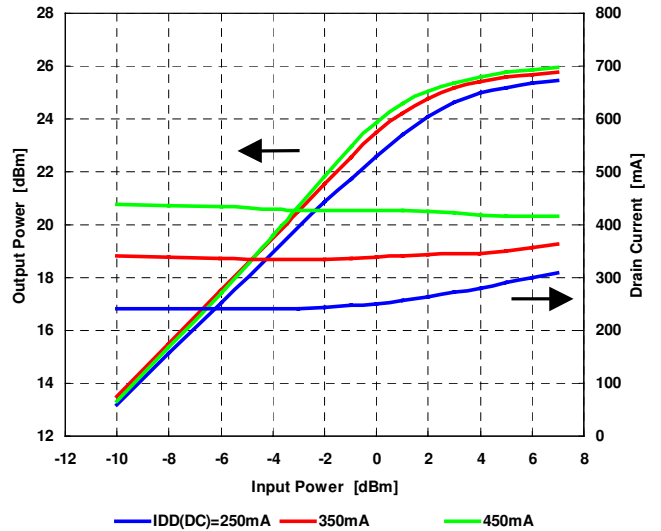

Output Power, Drain Current vs. Input Power by Drain Current

@f=14GHz, VDD=6V

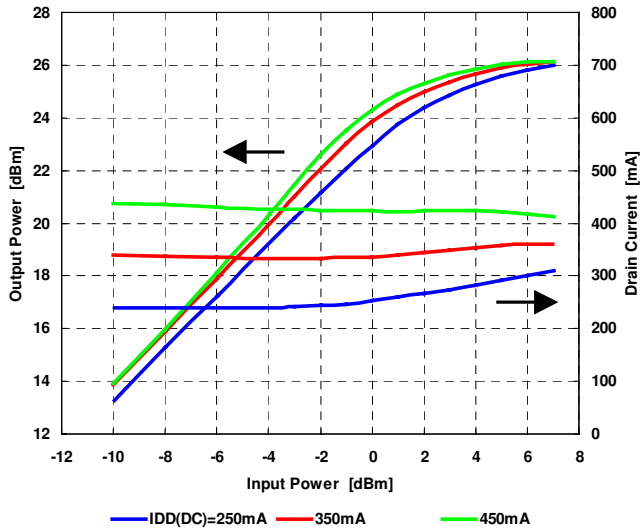

Output Power, Drain Current vs. Input Power by Drain Current

@f=15.4GHz, VDD=6V

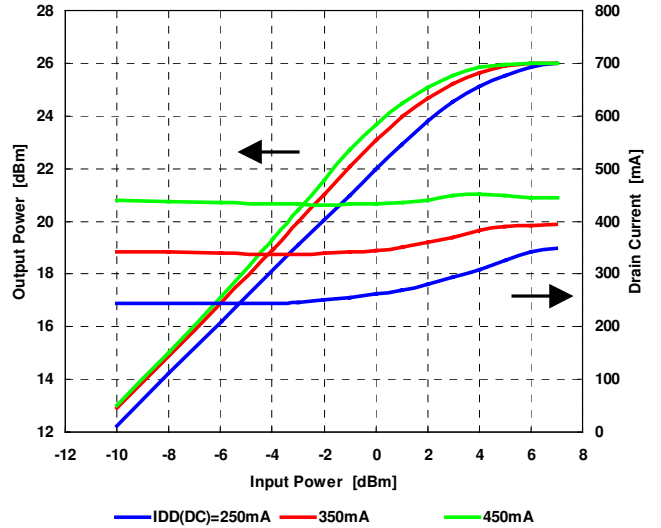

EMM5079X

X / Ku-band Power Amplifier MMIC

IMD vs. Output Power by Drain Voltage

@f=10GHz, IDD(DC)=350mA

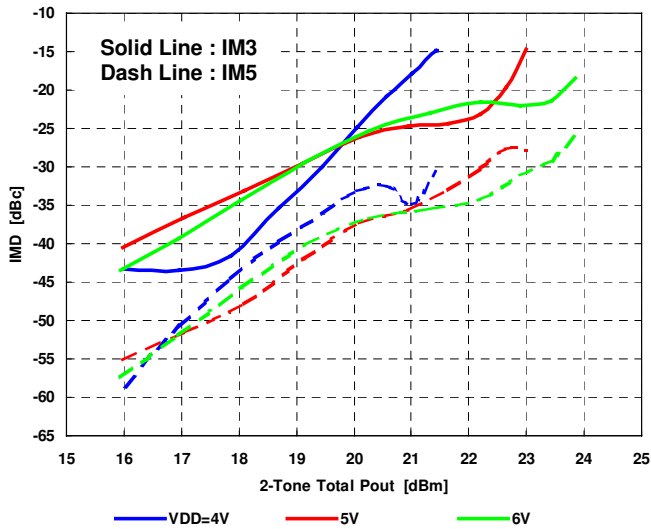

IMD vs. Output Power by Drain Voltage

@f=12GHz, IDD(DC)=350mA

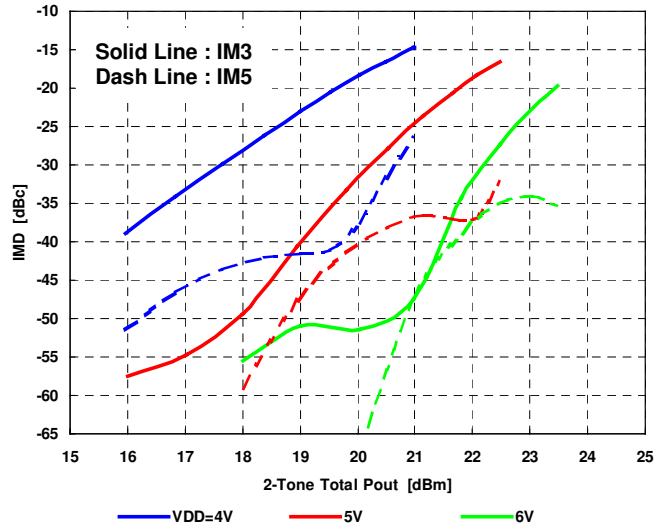

IMD vs. Output Power by Drain Voltage

@f=14GHz, IDD(DC)=350mA

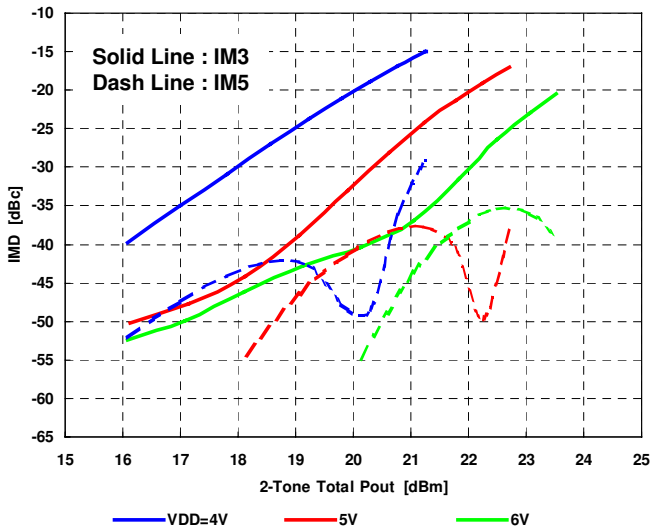

IMD vs. Output Power by Drain Voltage

@f=15.4GHz, IDD(DC)=350mA

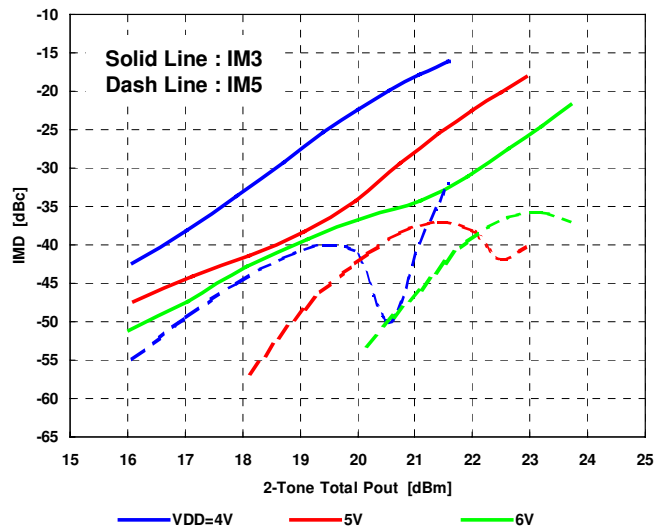

EMM5079X

X / Ku-Band Power Amplifier MMIC

IMD vs. Output Power by Drain Current

@f=10GHz, VDD=6V

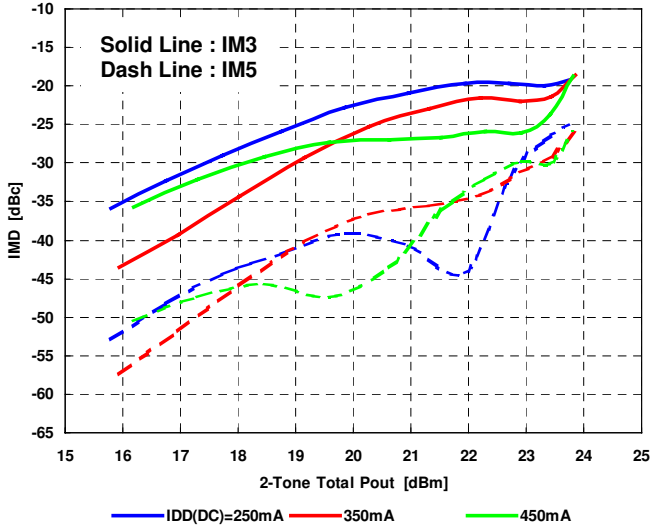

IMD vs. Output Power by Drain Current

@f=12GHz, VDD=6V

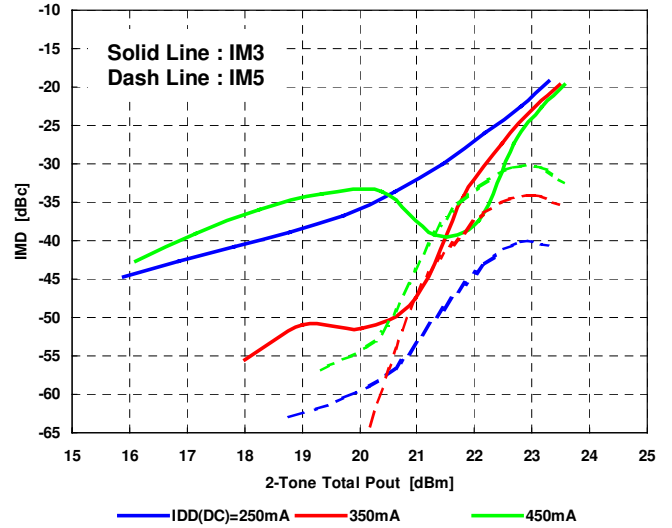

IMD vs. Output Power by Drain Current

@f=14GHz, VDD=6V

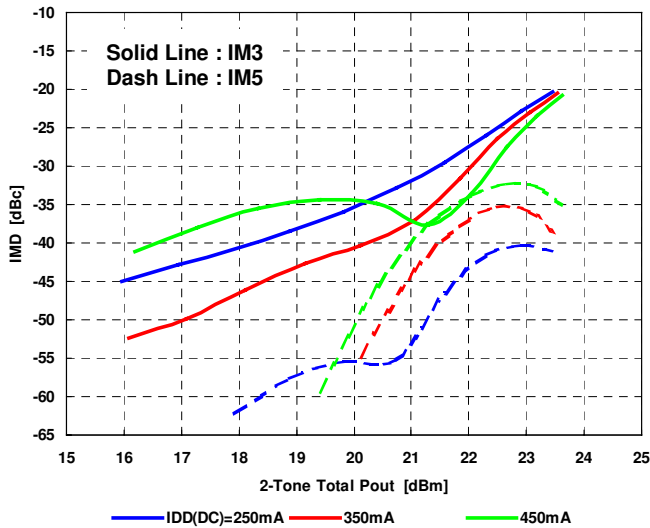

IMD vs. Output Power by Drain Current

@f=15.4GHz, VDD=6V

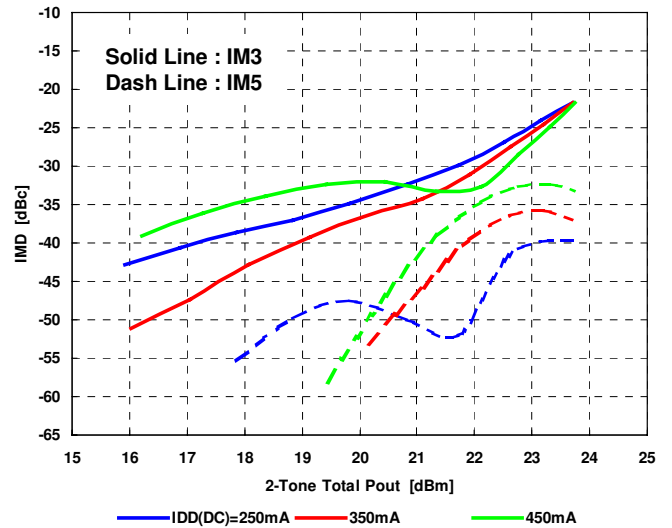

EMM5079X

X / Ku-band Power Amplifier MMIC

■ S-Parameter

VDD=6V, IDD=350mA

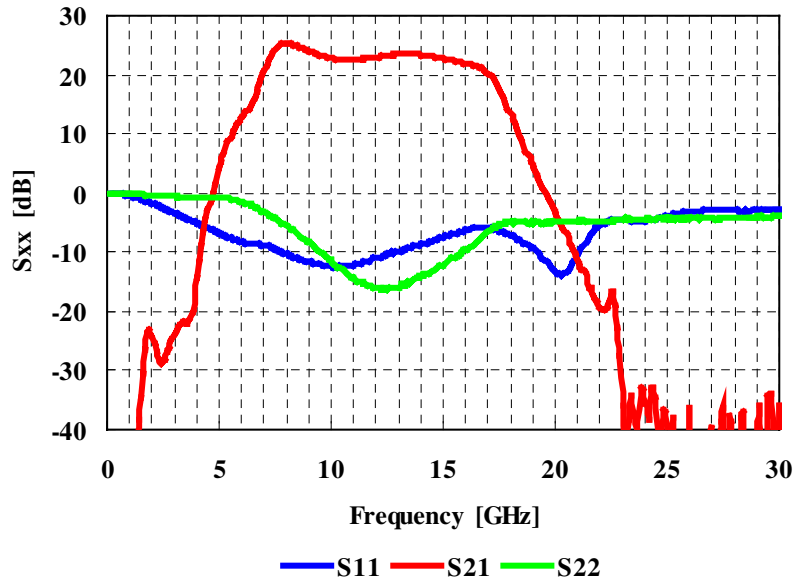

VDD=6V, IDD=350mA

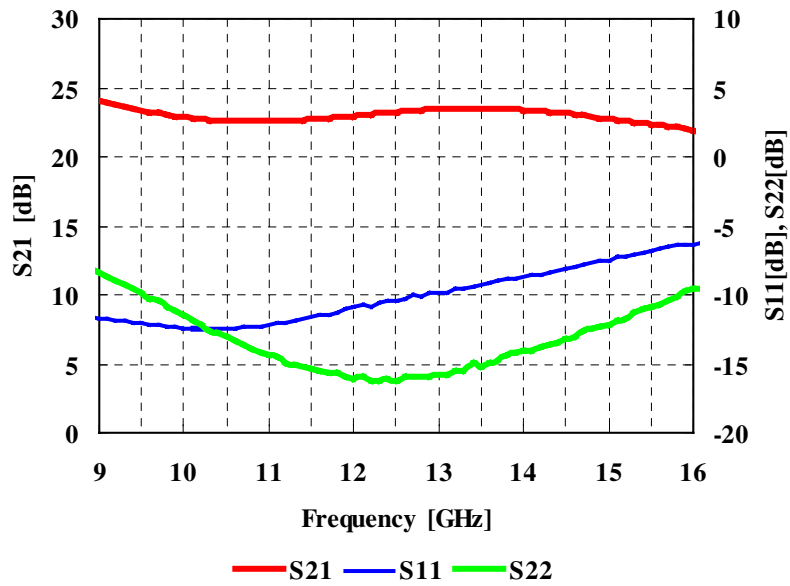

EMM5079X

X / Ku-Band Power Amplifier MMIC

■ S-Parameter

@VDD=6V, IDD=350mA

Frequency [GHz]	S11		S21		S12		S22	
	MAG	ANG	MAG	ANG	MAG	ANG	MAG	ANG
1.0	0.947	-35.4	0.004	34.1	0.001	105.7	0.997	-20.8
2.0	0.821	-88.0	0.063	-141.8	0.000	-82.0	0.952	-41.4
3.0	0.682	-96.6	0.064	175.9	0.000	-157.5	0.933	-63.0
4.0	0.557	-121.6	0.190	-172.8	0.001	25.2	0.905	-83.5
5.0	0.455	-142.7	1.610	98.1	0.000	-119.8	0.923	-108.8
6.0	0.387	-159.0	4.296	-7.3	0.001	-121.4	0.843	-140.9
7.0	0.362	-176.1	10.617	-87.5	0.000	132.8	0.692	-172.0
8.0	0.306	165.9	18.350	148.2	0.000	-106.6	0.526	159.6
9.0	0.261	156.9	15.910	50.4	0.000	25.7	0.382	135.7
10.0	0.240	152.3	13.898	-26.2	0.001	158.1	0.270	117.8
10.1	0.238	151.9	13.791	-33.4	0.001	-175.7	0.256	116.3
10.2	0.238	151.6	13.683	-40.4	0.002	-109.4	0.247	115.3
10.3	0.237	151.5	13.605	-47.3	0.002	28.0	0.235	113.7
10.4	0.239	151.0	13.535	-54.3	0.000	-166.7	0.232	113.5
10.5	0.240	151.6	13.489	-61.1	0.001	-79.9	0.224	112.4
10.6	0.240	151.0	13.445	-68.0	0.002	-151.4	0.216	111.8
10.7	0.242	151.0	13.421	-74.9	0.001	-80.5	0.208	110.8
10.8	0.243	150.9	13.415	-81.6	0.001	48.2	0.203	111.0
10.9	0.243	150.8	13.423	-88.5	0.001	-10.6	0.196	109.6
11.0	0.246	150.9	13.429	-95.3	0.001	112.2	0.190	109.3
11.1	0.249	150.7	13.469	-102.1	0.001	176.9	0.189	109.3
11.2	0.251	149.7	13.514	-109.0	0.001	-73.0	0.180	109.5
11.3	0.255	149.8	13.549	-115.9	0.001	-66.8	0.177	110.0
11.4	0.259	149.7	13.610	-122.7	0.000	107.5	0.174	110.4
11.5	0.263	148.8	13.699	-129.7	0.001	-124.1	0.170	109.9
11.6	0.266	148.1	13.749	-136.7	0.001	157.0	0.167	110.2
11.7	0.267	148.0	13.837	-143.7	0.001	-35.4	0.165	111.4
11.8	0.274	146.5	13.896	-150.7	0.003	51.1	0.166	109.9
11.9	0.279	147.1	13.976	-157.6	0.003	-173.3	0.159	112.2
12.0	0.285	146.2	14.078	-164.8	0.002	151.3	0.157	111.1
12.1	0.289	144.9	14.160	-171.9	0.005	119.3	0.158	111.9
12.2	0.288	144.6	14.273	-179.0	0.001	58.2	0.153	112.0
12.3	0.294	144.2	14.373	173.6	0.001	-171.1	0.155	113.8
12.4	0.300	143.5	14.440	166.3	0.003	128.9	0.157	112.2
12.5	0.302	141.9	14.538	159.0	0.001	48.0	0.154	114.1
12.6	0.308	141.2	14.612	151.5	0.002	107.9	0.158	115.5
12.7	0.314	140.6	14.689	144.2	0.002	-74.6	0.159	115.9
12.8	0.313	139.4	14.764	136.7	0.001	-152.0	0.159	116.0
12.9	0.320	138.5	14.812	129.2	0.002	124.7	0.158	115.3
13.0	0.322	138.1	14.849	121.6	0.002	130.5	0.162	116.1
13.1	0.323	137.0	14.924	114.0	0.002	95.0	0.162	117.4
13.2	0.330	136.0	14.947	106.4	0.001	54.8	0.169	118.2
13.3	0.335	135.9	15.004	98.7	0.002	102.9	0.168	117.5
13.4	0.340	134.5	15.011	91.0	0.000	-141.8	0.179	117.6
13.5	0.344	133.4	15.005	83.2	0.002	135.3	0.174	117.2
13.6	0.350	132.4	14.998	75.4	0.003	86.4	0.180	117.0
13.7	0.357	131.7	14.974	67.5	0.001	-176.4	0.183	117.5
13.8	0.359	130.2	14.893	59.7	0.003	97.2	0.192	117.1
13.9	0.359	128.8	14.857	52.0	0.003	-125.6	0.194	115.8
14.0	0.367	128.7	14.789	44.0	0.001	133.1	0.198	116.3
14.1	0.374	127.0	14.693	36.3	0.002	-52.7	0.197	116.4
14.2	0.376	126.7	14.612	28.3	0.002	54.0	0.206	116.3
14.3	0.378	126.2	14.532	20.5	0.004	138.7	0.207	117.1
14.4	0.386	124.3	14.458	12.7	0.001	125.5	0.212	116.3
14.5	0.393	124.1	14.353	4.6	0.002	136.3	0.220	116.1
14.6	0.400	122.6	14.228	-3.2	0.001	37.6	0.222	114.5
14.7	0.404	122.0	14.107	-11.2	0.005	151.0	0.233	115.8
14.8	0.412	120.4	13.968	-19.2	0.006	85.9	0.239	113.1
14.9	0.418	119.0	13.827	-27.1	0.002	47.3	0.242	113.3
15.0	0.421	118.1	13.742	-35.0	0.002	66.0	0.246	111.7
15.1	0.432	116.9	13.583	-43.0	0.004	93.2	0.254	111.7
15.2	0.436	115.6	13.467	-50.9	0.002	42.6	0.261	111.8
15.3	0.444	114.5	13.367	-59.1	0.002	-137.6	0.271	111.8
15.4	0.451	113.2	13.215	-67.2	0.002	90.5	0.280	110.4
15.5	0.455	110.9	13.116	-75.3	0.003	61.4	0.286	109.8
15.6	0.463	110.1	13.002	-83.7	0.002	116.4	0.292	107.9
15.7	0.469	108.4	12.883	-92.0	0.004	71.9	0.299	107.4
15.8	0.477	107.3	12.768	-100.4	0.003	-38.6	0.311	107.3
15.9	0.478	105.2	12.640	-109.0	0.003	138.8	0.327	105.2
16.0	0.484	103.6	12.524	-117.7	0.002	88.4	0.333	104.9
17.0	0.501	83.8	10.262	145.0	0.004	62.7	0.466	89.6
18.0	0.437	66.1	4.666	44.3	0.006	134.5	0.563	62.9
19.0	0.342	56.0	1.694	-28.0	0.006	-0.5	0.560	42.9

EMM5079X

X / Ku-band Power Amplifier MMIC

■ Chip Outline and Bonding Pad Locations (Dimension in Micro-Meters)

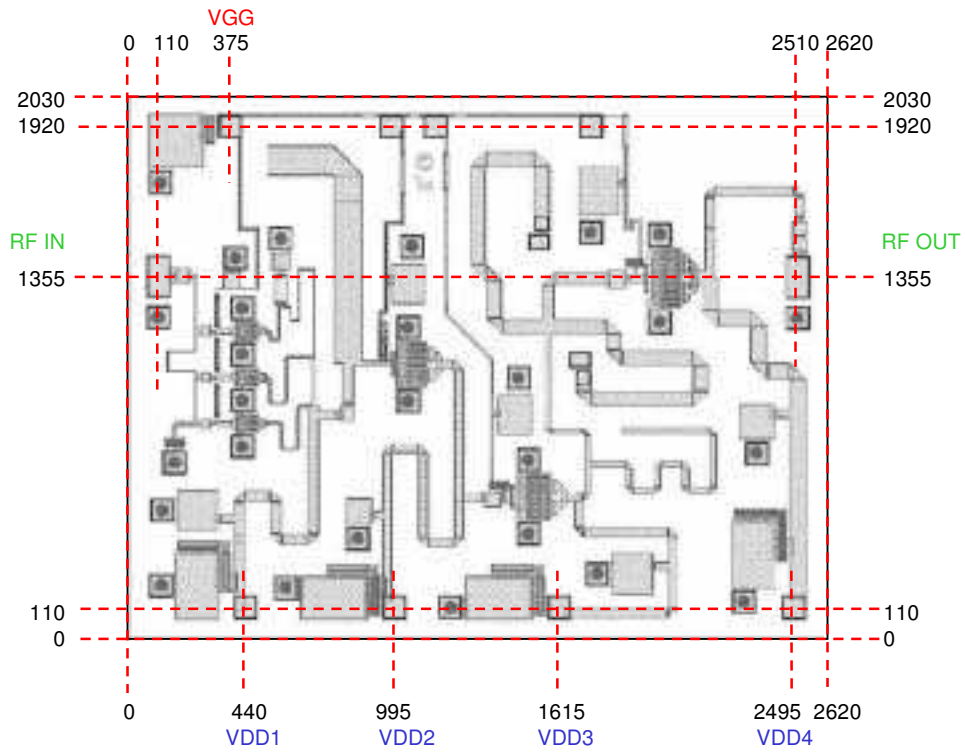

Chip Size : $2620 \pm 30 \mu\text{m} \times 2030 \pm 30 \mu\text{m}$

Chip Thickness : $85 \pm 20 \mu\text{m}$

Bonding Pad Size : $90 \mu\text{m} \times 90 \mu\text{m}$ (VDD, VGG), $160 \mu\text{m} \times 90 \mu\text{m}$ (RF)

EMM5079X

X / Ku-Band Power Amplifier MMIC

■ Assembly Diagrams

Recommended assembly

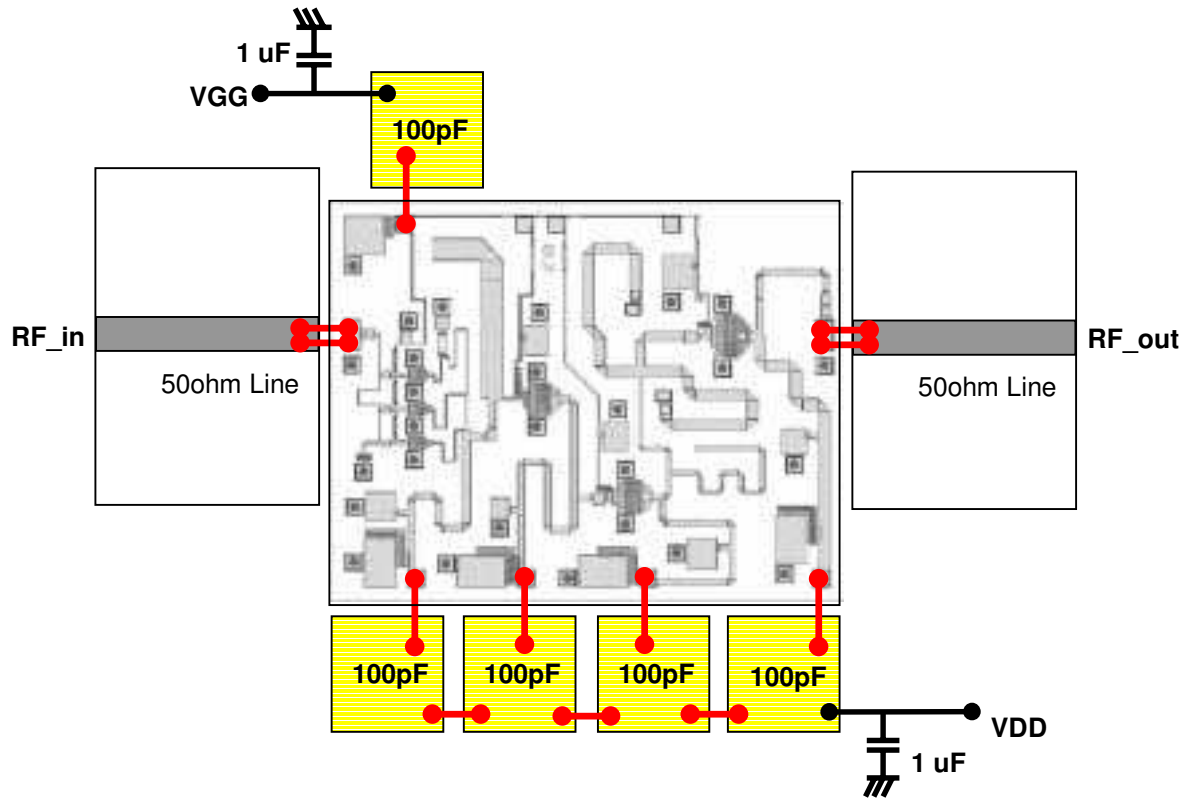

“Copper” is the recommended material for the package or carrier.

EMM5079X

X / Ku-band Power Amplifier MMIC

■ DIE ATTACH

- 1) The die-attach station must have accurate temperature control, and an inert forming gas should be used.
- 2) Chips should be kept at room temperature except during die-attach.
- 3) Place package or carrier on the heated stage.
- 4) Lightly grasp the chip edges by the longer side using tweezers.

Die attach conditions

Stage Temperature : 300 to 310 deg.C

Time : less than 15 seconds

AuSn Preform Volume : per next Figure

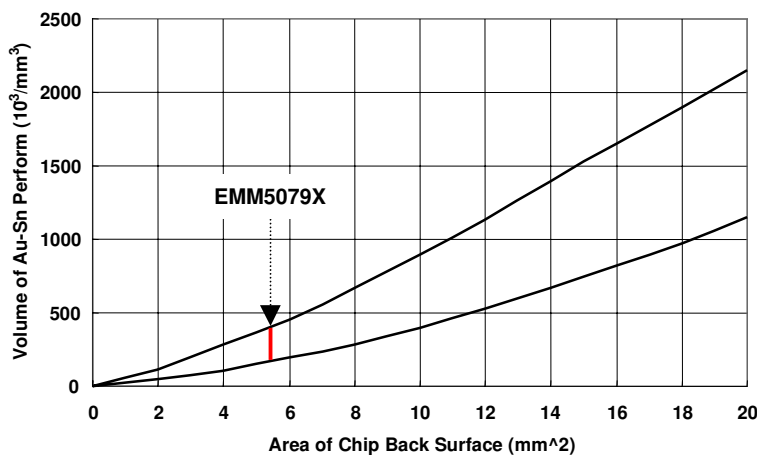

■ WIRE BONDING

The bonding equipment must be properly grounded. The following or equivalent equipment, tools, materials, and conditions are recommended.

1) Bonding Equipment and Bonding Tool.

Bonding Equipment : West Bond Model 7400 (Manual Bonder)

Bonding Tool : CCOD-1/16-S-437-60-F-2010-MP (Deweyl)

2) Bonding Wire

Material : Hard or Half hard gold

Diameter : 0.7 to 1.0 mil

3) Bonding Conditions

Method : Thermal Compression Bonding with Ultrasonic Power

Tool Force : 0.196 N ± 0.0196 N

Stage Temperature : 215 deg.C ± 5 deg.C

Tool Heater : None

Ultrasonic Power Transmitter : West Bond Model 1400

Duration : 150 mS/Bond

EMM5079X

X / Ku-Band Power Amplifier MMIC

For further information please contact :

Eudyna Devices USA Inc.

2355 Zanker Rd.
San Jose, CA 95131-1138, U.S.A.
TEL: +1 408 232-9500
FAX: +1 408 428-9111

Eudyna Devices Europe Ltd.

150 Edinburgh Avenue
Slough, Berkshire, SL1 4SS
United Kingdom
TEL: +44(0)1753-849950
FAX: +44(0)1753-577128

Eudyna Devices International Srl

Via Teglio 8/2 - 20158
Milano, Italy
TEL: +39-02-37052921
FAX: +39-02-37052920

Eudyna Devices Asia Pte. Ltd.

Hong Kong Branch
Suite 1906B, Tower 6, China Hong Kong City
33 Canton Road, Tsimshatsui, Kowloon
Hong Kong
TEL: +852-2377-0227
FAX: +852-2377-3921

Eudyna Devices Inc.

1000 Kamisukiahara, showa-cho
Nakakomagun, Yamanashi
409-3883, Japan
(Kokubo Industrial Park)
TEL +81-55-275-4411
FAX +81-55-275-9461

Sales Division

1, Kanai-cho, Sakae-ku
Yokohama, 244-0845, Japan
TEL +81-45-853-8156
FAX +81-45-853-8170

CAUTION

Eudyna Devices Inc. products contain **gallium arsenide (GaAs)** which can be hazardous to the human body and the environment. For safety, observe the following procedures:

- Do not put these products into the mouth.
- Do not alter the form of this product into a gas, powder, or liquid through burning, crushing, or chemical processing as these by-products are dangerous to the human body if inhaled, ingested, or swallowed.
- Observe government laws and company regulations when discarding this product. This product must be discarded in accordance with methods specified by applicable hazardous waste procedures.

Eudyna Devices Inc. reserves the right to change products and specifications without notice. The information does not convey any license under rights of Eudyna Devices Inc. or others.

© 2008 Eudyna Devices Inc.

