

EMM5078X

C-Band Power Amplifier MMIC

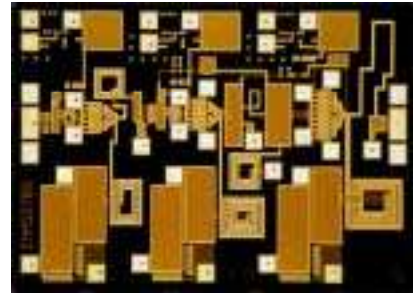

FEATURES

- High Output Power: Pout = 26 dBm (Typ.)
- High Linear Gain: GL = 30 dB(Typ.)
- Broad Band: 3.4 – 8.5 GHz
- Impedance Matched Zin/Zout = 50Ω

DESCRIPTION

The EMM5078X is a wide band power amplifier MMIC that contains a three stage amplifier, internally matched, for standard communications band in 3.4 to 8.5GHz frequency range. Eudyna's stringent Quality Assurance Program assures the highest reliability and consistent performance.

ABSOLUTE MAXIMUM RATING

Item	Symbol	Rating	Unit
Drain-Source Voltage	V _{DD}	10	V
Gate-Source Voltage	V _{GG}	-3	V
Input Power	P _{in}	22	dBm
Storage Temperature	T _{stg}	-55 to +125	°C

RECOMMENDED OPERATING CONDITIONS

Item	Symbol	Condition	Unit
Drain-Source Voltage	V _{DD}	<=6	V
Input Power	P _{in}	<=2	dBm
Operating Backside Temperature	Top	-40 to +85	°C

This product should be hermetically packaged.

ELECTRICAL CHARACTERISTICS (Ambient Temperature Ta=25°C)

Item	Symbol	Test Conditions	Limits			Unit
			Min.	Typ.	Max.	
Frequency Range	f	V _{DD} =6V	3.4	-	8.5	GHz
Output Power at 1dB G.C.P.	P _{1dB}	I _{DD} (DC)=300mA typ.	23.0	26.0	-	dBm
Power Gain at 1dB G.C.P.	G _{1dB}	Z _s =Z _l =50ohm	24	29	-	dB
Power-added Efficiency at 1dB G.C.P.	η _{add}		-	18	-	%
Third Order Intermodulation*	IM ₃	*:Δf=10MHz ,	-35	-40	-	dBc
Drain Current at 1dB G.C.P.	IDD	2-Tone Test,	-	350	450	mA
Input Return Loss (at Pin=-20dBm)	RL _{in}	Pout=15dBm S.C.L.	-	-10	-	dB
Output Return Loss (at Pin=-20dBm)	RL _{out}		-	-10	-	dB

Note : RF parameter sample size 10pcs. Criteria (accept/reject)=(0/1)

G.C.P.:Gain Compression Point
S.C.L.:Single Carrier Level

ESD	Class 0	~ 249V
------------	----------------	---------------

Note : Based on JEDEC JESD22-A114C

RoHs Compliance	Yes
------------------------	------------

EMM5078X

C-band Power Amplifier MMIC

Output Power vs. Frequency

@VDD=6V, IDD(DC)=300mA

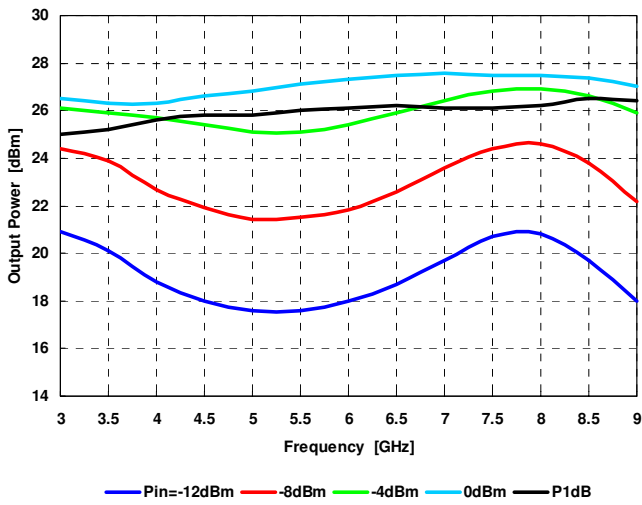

Output Power, Drain Current vs. Input Power

@VDD=6V, IDD(DC)=300mA

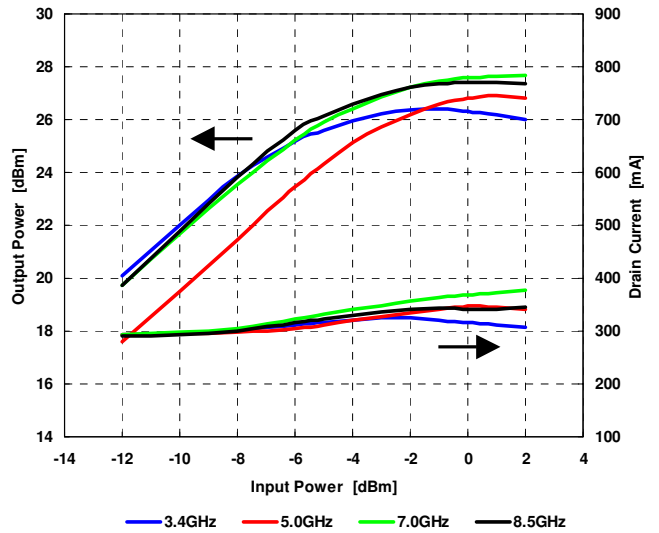

Power Added Efficiency vs. Frequency

@VDD=6V, IDD(DC)=300mA

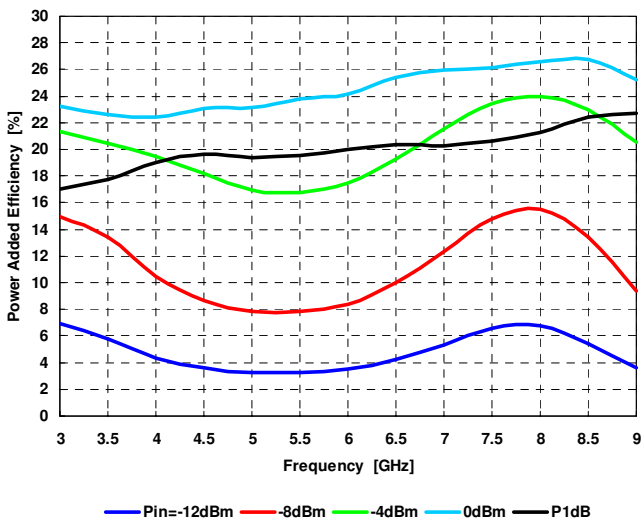

EMM5078X

C-Band Power Amplifier MMIC

IM3 vs. Frequency

@VDD=6V, IDD(DC)=350mA, @Po=15dBm S.C.L.

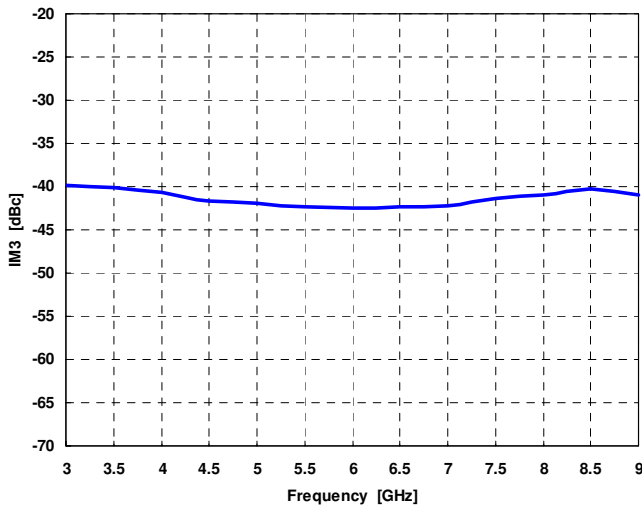

IMD vs. Output Power

@VDD=6V, IDD(DC)=300mA

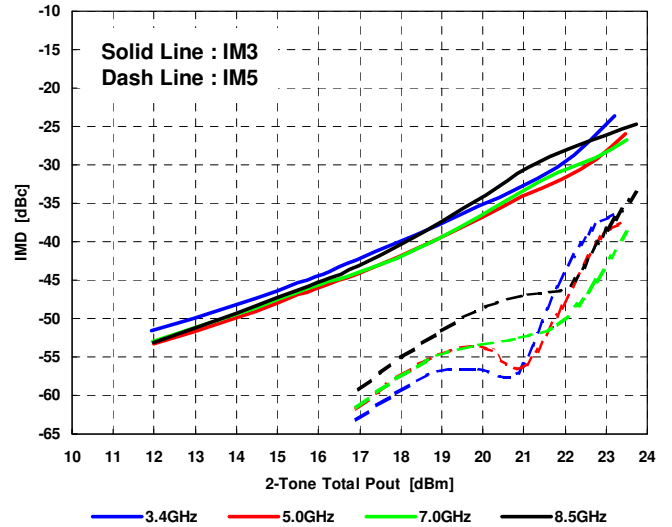

P1dB, G1dB vs. Frequency by Drain Voltage

@IDD(DC)=300mA

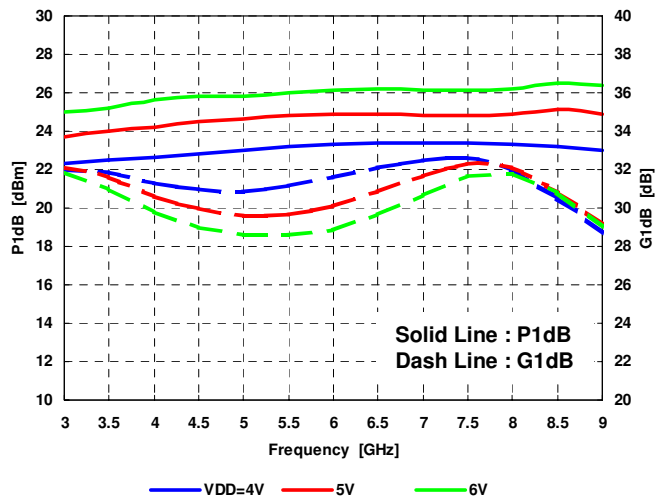

P1dB, G1dB vs. Frequency by Drain Current

@VDD=6V

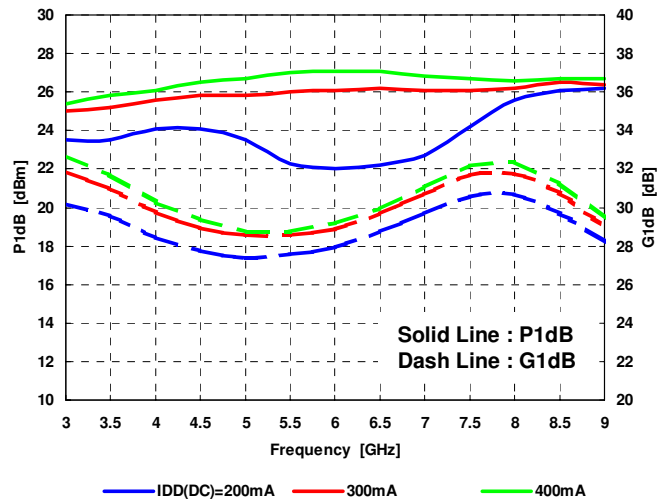

EMM5078X

C-band Power Amplifier MMIC

Output Power, Drain Current vs. Input Power by Drain Voltage

@f=3.4GHz, IDD(DC)=300mA

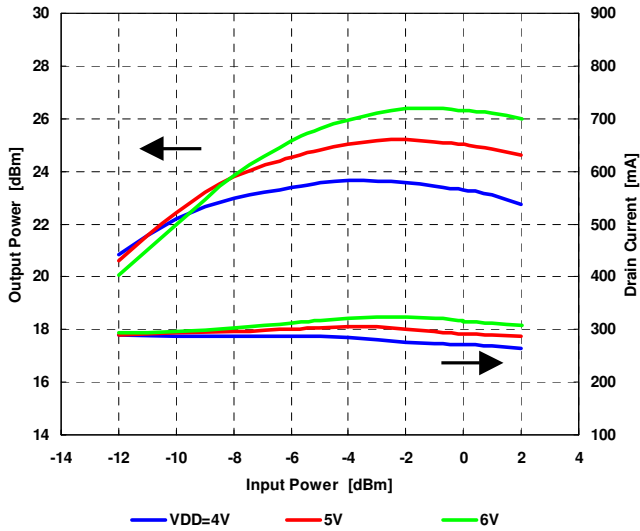

Output Power, Drain Current vs. Input Power by Drain Voltage

@f=5.0GHz, IDD(DC)=300mA

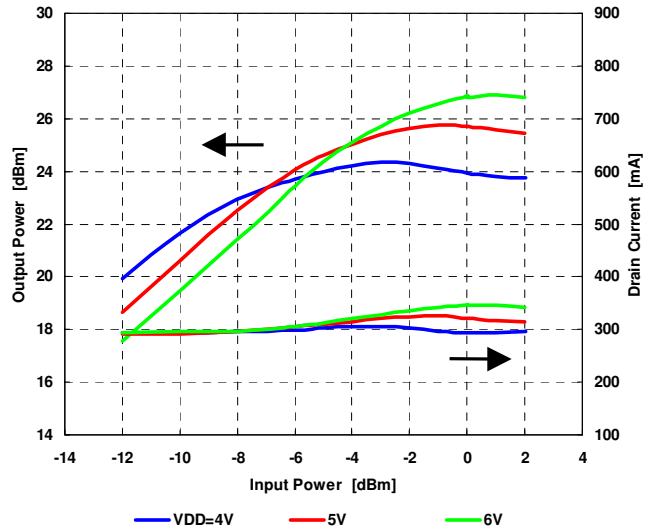

Output Power, Drain Current vs. Input Power by Drain Voltage

@f=7.0GHz, IDD(DC)=300mA

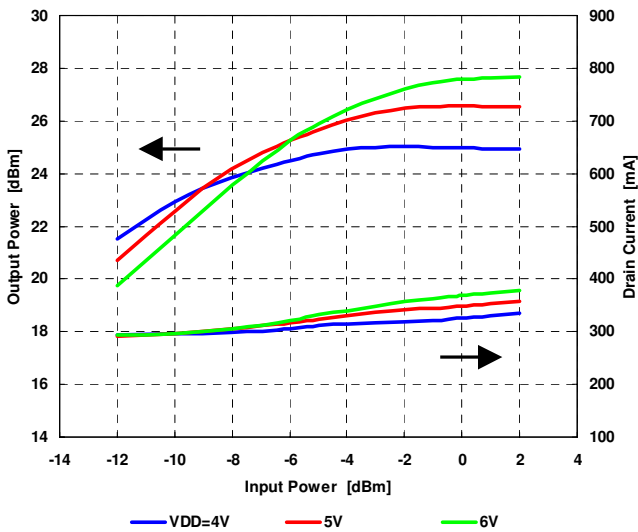

Output Power, Drain Current vs. Input Power by Drain Voltage

@f=8.5GHz, IDD(DC)=300mA

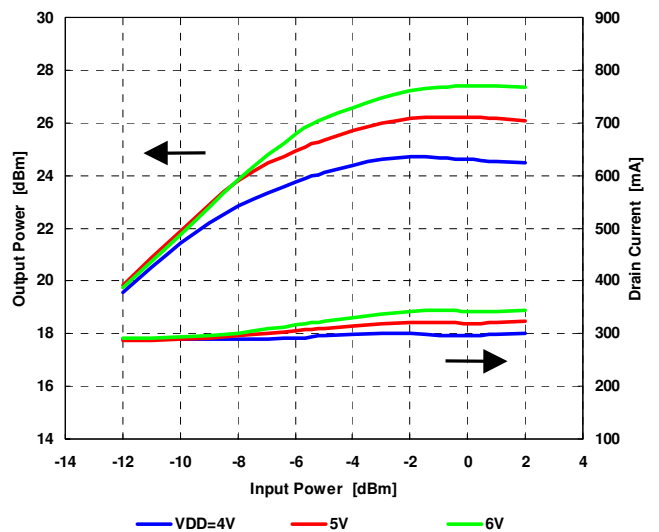

EMM5078X

C-Band Power Amplifier MMIC

Output Power, Drain Current vs. Input Power by Drain Current

@f=3.4GHz, VDD=6V

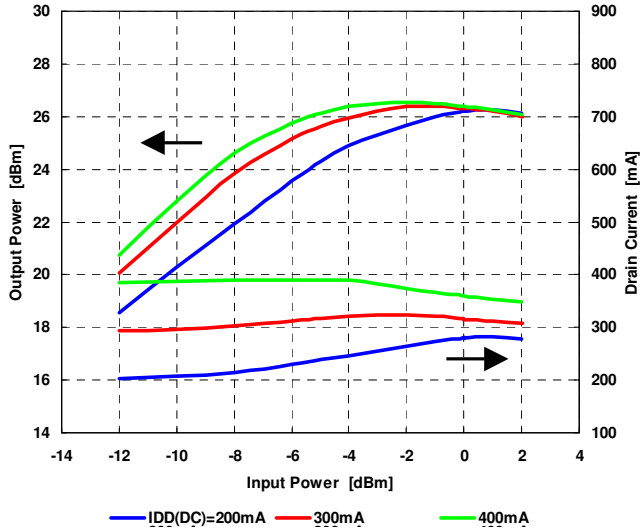

Output Power, Drain Current vs. Input Power by Drain Current

@f=5.0GHz, VDD=6V

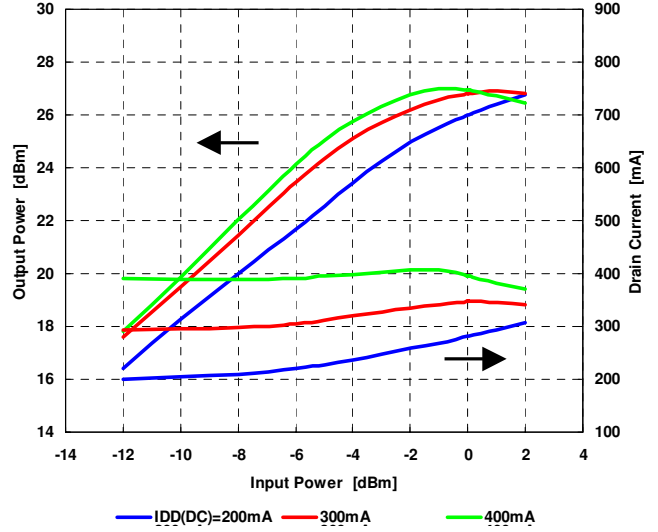

Output Power, Drain Current vs. Input Power by Drain Current

@f=7.0GHz, VDD=6V

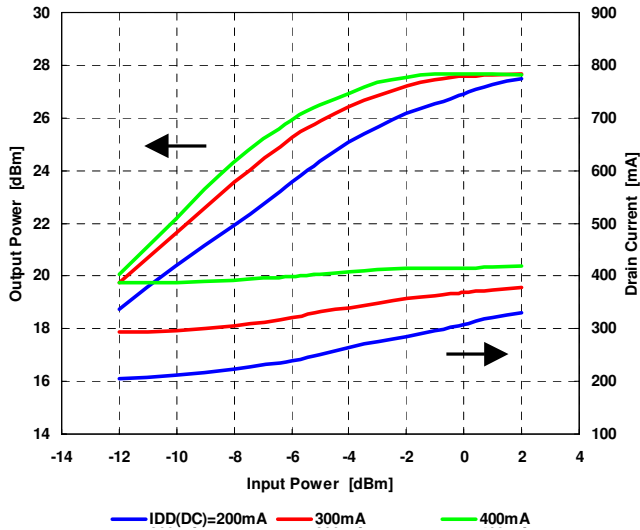

Output Power, Drain Current vs. Input Power by Drain Current

@f=8.5GHz, VDD=6V

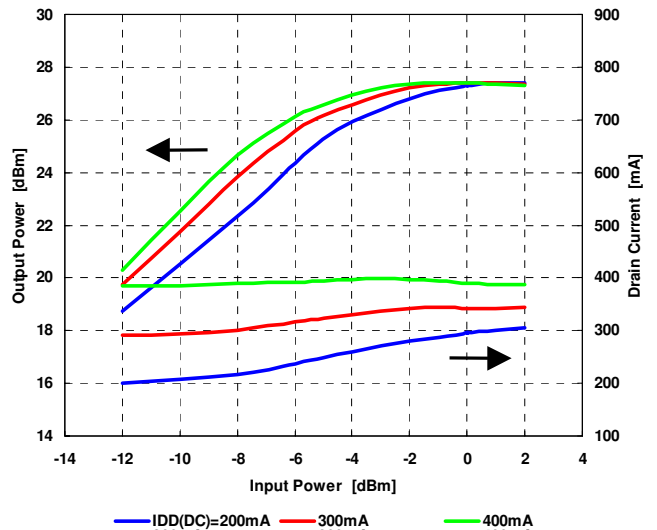

EMM5078X

C-band Power Amplifier MMIC

IMD vs. Output Power by Drain Voltage

@f=3.4GHz, IDD(DC)=300mA

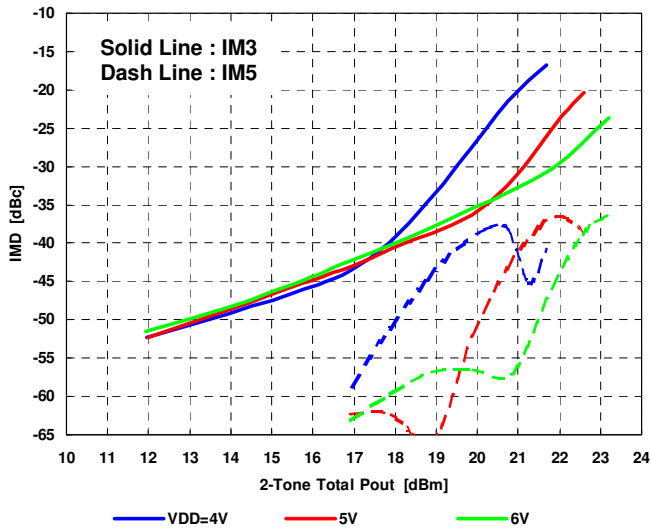

IMD vs. Output Power by Drain Voltage

@f=5.0GHz, IDD(DC)=300mA

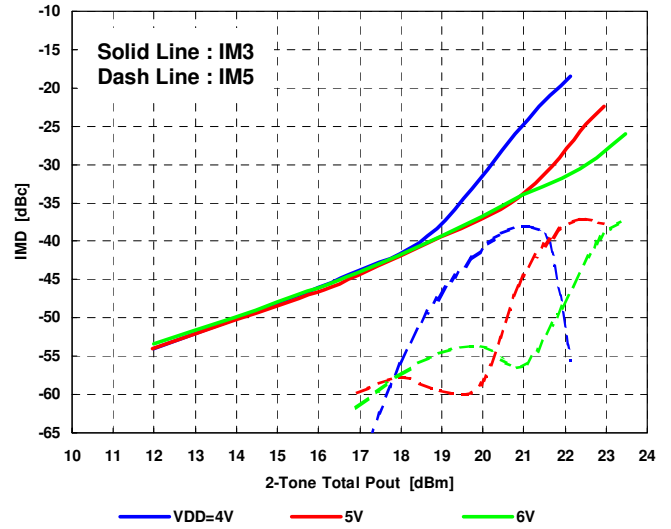

IMD vs. Output Power by Drain Voltage

@f=7.0GHz, IDD(DC)=300mA

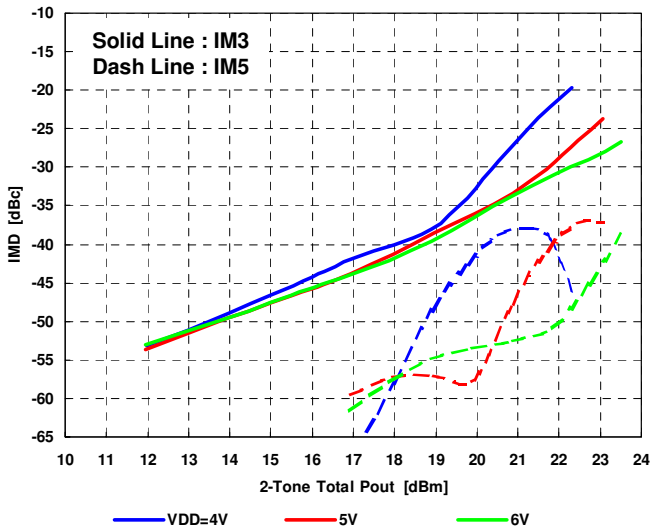

IMD vs. Output Power by Drain Voltage

@f=8.5GHz, IDD(DC)=300mA

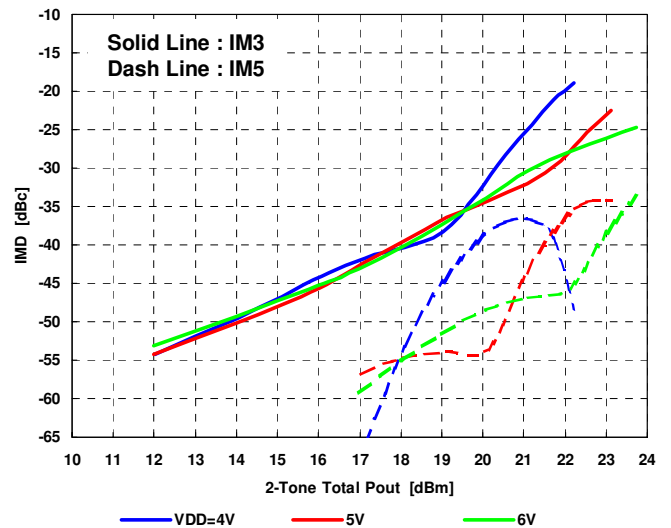

EMM5078X

C-Band Power Amplifier MMIC

IMD vs. Output Power by Drain Current

@f=3.4GHz, VDD=6V

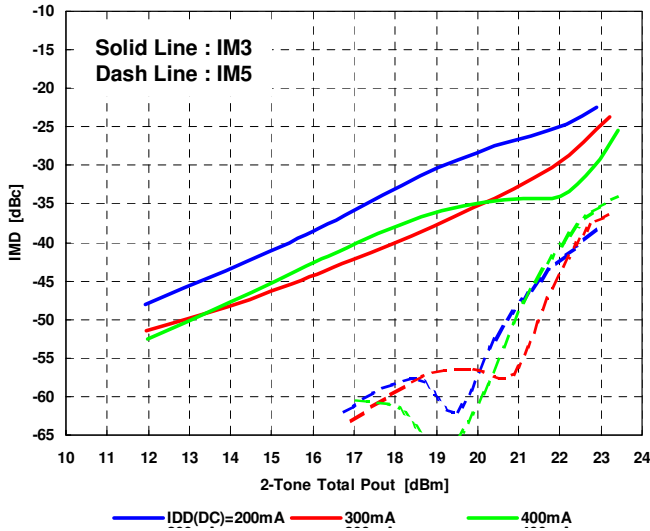

IMD vs. Output Power by Drain Current

@f=5.0GHz, VDD=6V

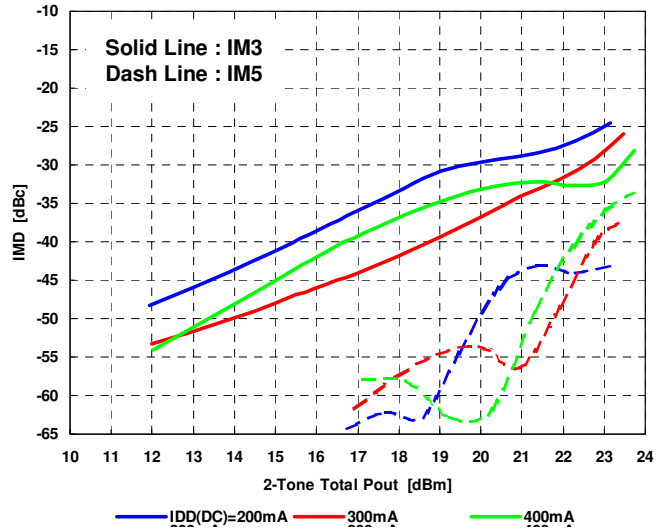

IMD vs. Output Power by Drain Current

@f=7.0GHz, VDD=6V

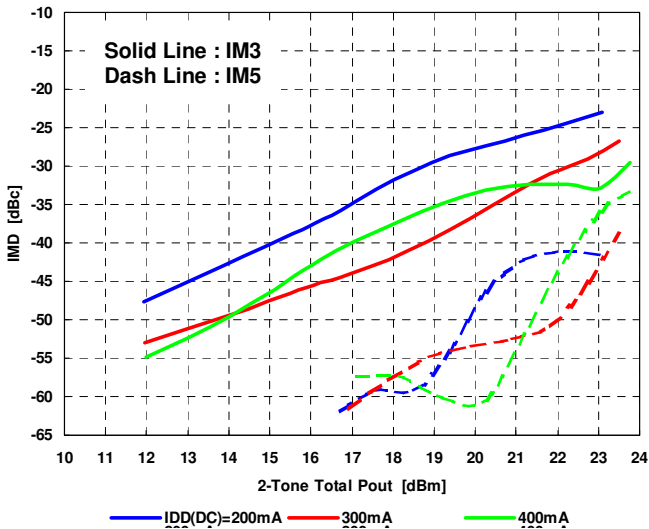

IMD vs. Output Power by Drain Current

@f=8.5GHz, VDD=6V

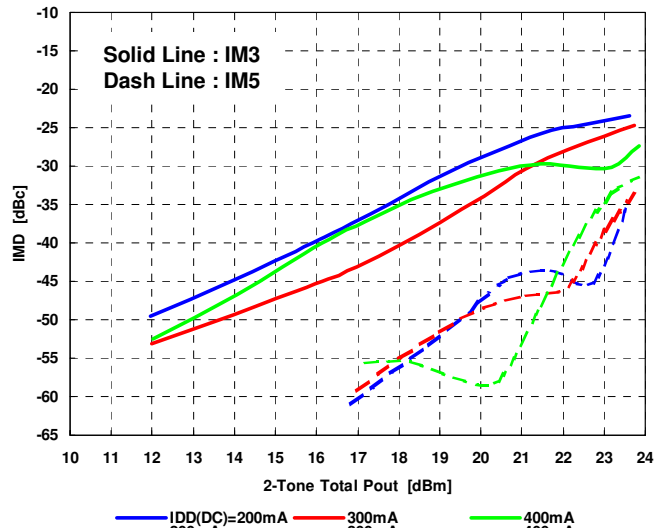

EMM5078X

C-band Power Amplifier MMIC

■ S-Parameter

VDD/IDD(DC)=6V/300mA

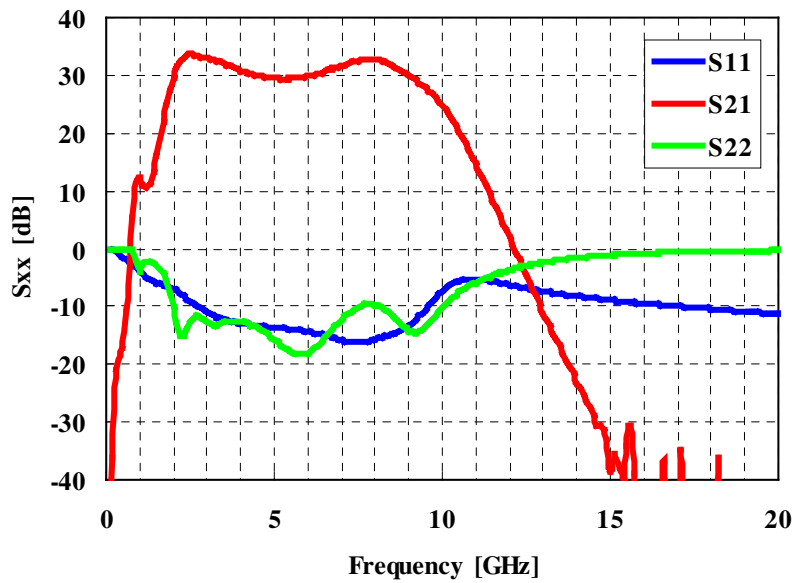

VDD/IDD(DC)=6V/300mA

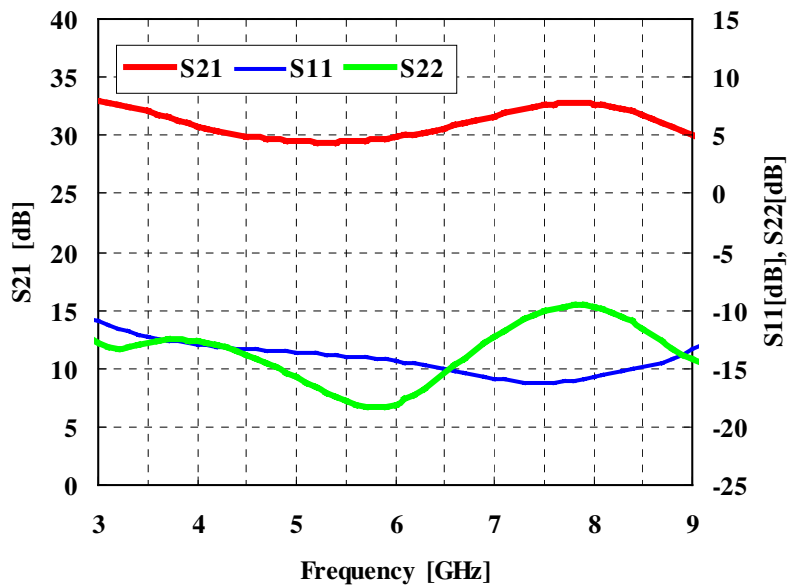

EMM5078X

C-Band Power Amplifier MMIC

■ S-Parameter

VDD=6V, IDD(DC)=300mA

Frequency [GHz]	S11		S21		S12		S22	
	MAG	ANG	MAG	ANG	MAG	ANG	MAG	ANG
1.0	0.635	-54.5	4.197	32.3	0.001	-85.8	0.640	-81.5
2.0	0.450	-77.8	30.316	-85.9	0.000	55.2	0.310	-166.2
3.0	0.282	-95.5	44.371	96.0	0.000	164.7	0.229	-138.8
3.1	0.272	-96.3	43.902	83.6	0.000	166.9	0.220	-137.8
3.2	0.264	-97.1	43.096	71.4	0.000	145.8	0.217	-136.3
3.3	0.256	-97.6	42.303	59.6	0.000	130.3	0.219	-135.1
3.4	0.250	-98.1	41.078	48.3	0.000	122.8	0.224	-134.8
3.5	0.244	-98.6	40.021	37.5	0.000	95.6	0.229	-135.5
3.6	0.239	-99.2	38.846	27.3	0.000	108.9	0.233	-136.8
3.7	0.235	-99.8	37.689	17.4	0.000	63.1	0.236	-138.6
3.8	0.231	-100.4	36.677	8.0	0.000	60.8	0.236	-140.6
3.9	0.229	-101.2	35.635	-1.1	0.000	79.5	0.236	-142.7
4.0	0.225	-101.9	34.722	-9.8	0.000	58.7	0.233	-144.7
4.1	0.223	-102.7	33.947	-18.4	0.000	61.9	0.229	-146.7
4.2	0.220	-103.7	33.140	-26.8	0.000	77.0	0.224	-148.5
4.3	0.218	-104.9	32.546	-34.8	0.000	70.6	0.218	-150.3
4.4	0.217	-106.1	31.888	-42.7	0.000	54.2	0.211	-151.8
4.5	0.215	-107.3	31.375	-50.5	0.000	69.5	0.204	-153.0
4.6	0.214	-108.8	30.904	-58.3	0.000	52.2	0.197	-154.2
4.7	0.212	-110.2	30.602	-65.8	0.000	44.6	0.188	-155.0
4.8	0.211	-111.7	30.260	-73.2	0.000	57.5	0.180	-155.5
4.9	0.210	-113.4	30.028	-80.6	0.000	60.2	0.172	-155.7
5.0	0.208	-115.3	29.828	-87.9	0.000	40.9	0.163	-155.4
5.1	0.207	-117.2	29.767	-95.2	0.000	35.2	0.155	-154.7
5.2	0.206	-119.2	29.596	-102.5	0.000	55.3	0.147	-153.5
5.3	0.204	-121.4	29.628	-109.7	0.000	27.5	0.140	-151.7
5.4	0.203	-123.6	29.629	-116.9	0.000	31.7	0.134	-149.5
5.5	0.201	-126.4	29.747	-124.1	0.000	-10.4	0.128	-146.4
5.6	0.200	-129.1	29.937	-131.3	0.000	-9.2	0.124	-142.9
5.7	0.198	-131.9	30.100	-138.5	0.000	21.7	0.121	-138.7
5.8	0.196	-135.0	30.437	-145.8	0.000	-11.5	0.121	-134.5
5.9	0.194	-138.1	30.749	-153.2	0.000	4.4	0.122	-130.1
6.0	0.191	-141.6	31.130	-160.7	0.000	-1.7	0.125	-125.8
6.1	0.189	-145.4	31.603	-168.1	0.000	-10.0	0.131	-122.1
6.2	0.186	-149.3	32.060	-175.7	0.000	5.0	0.138	-118.8
6.3	0.183	-153.9	32.625	176.6	0.000	-22.9	0.147	-116.1
6.4	0.181	-158.5	33.322	168.8	0.000	-25.1	0.157	-114.1
6.5	0.178	-163.5	34.010	160.8	0.000	-26.6	0.169	-112.9
6.6	0.174	-169.0	34.772	152.7	0.000	-42.4	0.183	-112.6
6.7	0.171	-174.9	35.483	144.4	0.000	-43.9	0.196	-112.8
6.8	0.168	178.7	36.428	135.9	0.000	-56.9	0.211	-113.9
6.9	0.165	171.8	37.308	127.1	0.000	-62.5	0.227	-115.4
7.0	0.162	164.3	38.210	118.2	0.000	-56.2	0.243	-117.4
7.1	0.159	156.4	39.127	108.9	0.000	-73.4	0.258	-120.1
7.2	0.157	147.7	40.012	99.5	0.000	-78.0	0.273	-123.3
7.3	0.155	138.4	40.906	89.7	0.000	-88.2	0.287	-127.0
7.4	0.155	128.6	41.781	79.7	0.000	-95.4	0.301	-131.1
7.5	0.155	118.7	42.344	69.4	0.000	-107.5	0.312	-135.8
7.6	0.155	108.5	43.101	58.6	0.001	-113.9	0.321	-141.0
7.7	0.157	98.4	43.317	47.8	0.001	-121.6	0.328	-146.5
7.8	0.159	88.2	43.499	36.8	0.001	-132.1	0.331	-152.5
7.9	0.161	78.6	43.524	25.6	0.001	-140.7	0.331	-159.0
8.0	0.165	69.5	43.111	14.3	0.001	-144.6	0.327	-165.6
8.1	0.167	61.0	42.735	2.8	0.001	-159.2	0.319	-172.7
8.2	0.171	53.4	41.744	-8.7	0.001	-168.2	0.309	179.9
8.3	0.173	46.3	40.924	-20.0	0.001	-175.7	0.295	172.3
8.4	0.176	40.2	39.901	-31.3	0.001	174.8	0.282	164.1
8.5	0.181	34.9	38.708	-42.7	0.001	171.1	0.265	155.3
8.6	0.185	30.6	37.334	-53.8	0.001	156.3	0.249	146.4
8.7	0.189	26.9	35.809	-65.0	0.001	151.3	0.231	136.4
8.8	0.195	23.8	34.352	-76.1	0.001	143.8	0.215	125.7
8.9	0.203	21.3	32.993	-87.1	0.001	127.6	0.203	114.5
9.0	0.214	19.0	31.483	-98.1	0.000	125.7	0.194	102.1
10.0	0.427	-13.0	17.319	148.7	0.000	17.6	0.309	-2.5
11.0	0.542	-60.8	5.437	38.7	0.000	-70.9	0.507	-46.0
12.0	0.482	-90.6	1.224	-41.5	0.000	-106.5	0.654	-70.4
13.0	0.425	-107.7	0.275	-99.8	0.000	-107.5	0.758	-87.8
14.0	0.387	-119.5	0.069	-136.6	0.000	-130.3	0.832	-101.4
15.0	0.359	-128.9	0.012	170.8	0.000	-153.3	0.882	-112.5
16.0	0.337	-136.7	0.006	164.6	0.000	-167.0	0.913	-121.7
17.0	0.317	-143.5	0.001	-144.4	0.000	-144.5	0.934	-129.6
18.0	0.301	-149.6	0.002	-47.6	0.001	-159.0	0.947	-136.4
19.0	0.286	-155.0	0.004	142.7	0.001	-178.6	0.956	-142.3

EMM5078X

C-band Power Amplifier MMIC

■ Chip Outline and Bonding Pad Locations (Dimension in Micro-Meters)

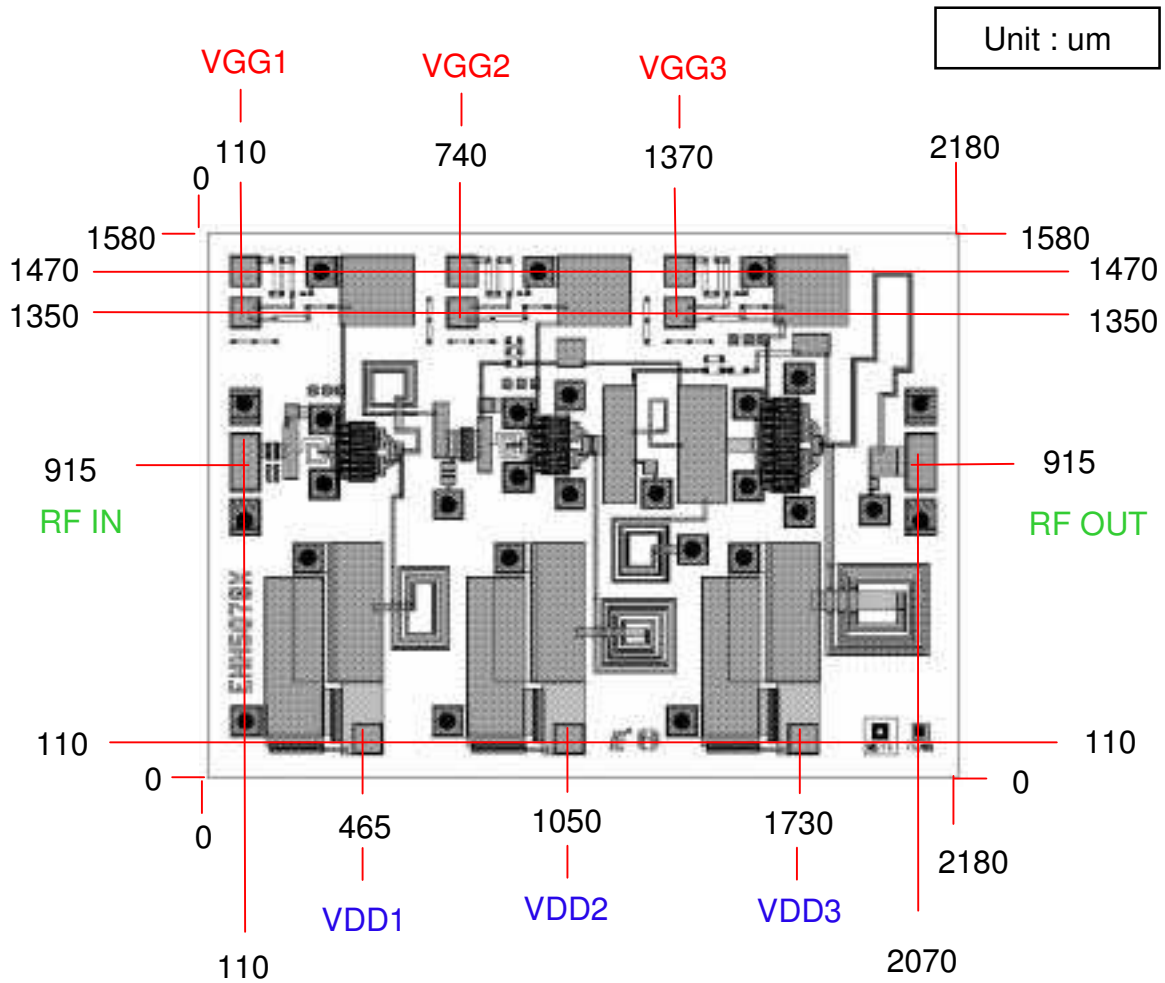

Chip Size : $2180 \pm 30 \mu\text{m} \times 1580 \pm 30 \mu\text{m}$

Chip Thickness : $85 \pm 20 \mu\text{m}$

Bonding Pad Size : $90 \mu\text{m} \times 90 \mu\text{m}$ (VDD, VGG), $90 \mu\text{m} \times 170 \mu\text{m}$ (RF)

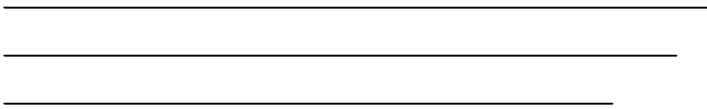

EMM5078X

C-Band Power Amplifier MMIC

■ Assembly Diagrams

Recommended assembly

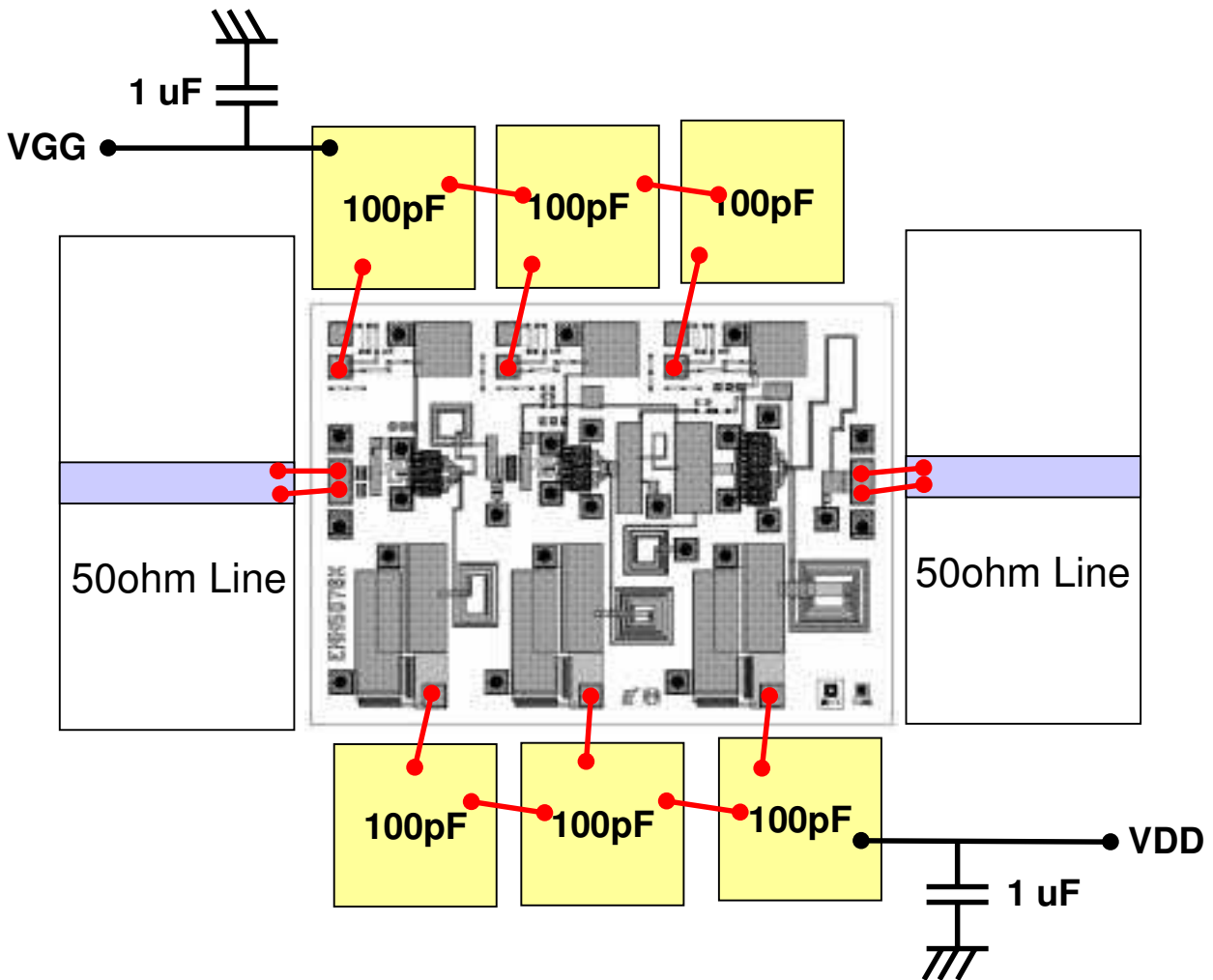

“Copper” is the recommended material for the package or carrier.

EMM5078X

C-band Power Amplifier MMIC

■ DIE ATTACH

- 1) The die-attach station must have accurate temperature control, and an inert forming gas should be used.
- 2) Chips should be kept at room temperature except during die-attach.
- 3) Place package or carrier on the heated stage.
- 4) Lightly grasp the chip edges by the longer side using tweezers.

Die attach conditions

Stage Temperature : 300 to 310 deg.C

Time : less than 15 seconds

AuSn Preform Volume : per next Figure

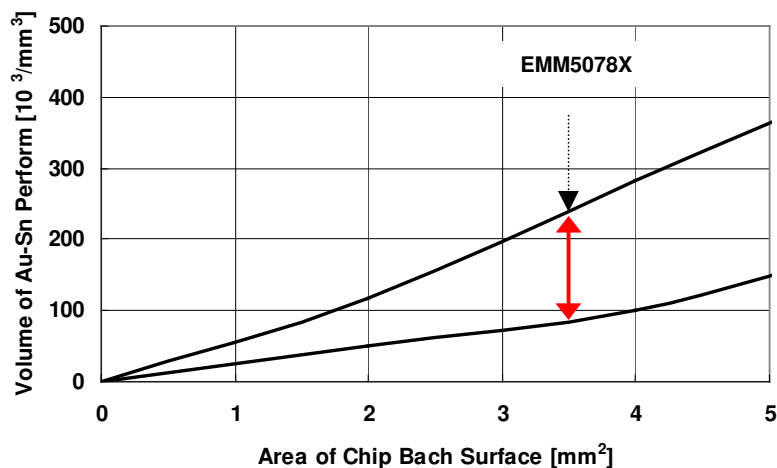

■ WIRE BONDING

The bonding equipment must be properly grounded. The following or equivalent equipment, tools, materials, and conditions are recommended.

1) Bonding Equipment and Bonding Tool.

Bonding Equipment : West Bond Model 7400 (Manual Bonder)

Bonding Tool : CCOD-1/16-S-437-60-F-2010-MP (Deweyl)

2) Bonding Wire

Material : Hard or Half hard gold

Diameter : 0.7 to 1.0 mil

3) Bonding Conditions

Method : Thermal Compression Bonding with Ultrasonic Power

Tool Force : 0.196 N +/- 0.0196 N

Stage Temperature : 215 deg.C +/- 5 deg.C

Tool Heater : None

Ultrasonic Power Transmitter : West Bond Model 1400

Duration : 150 mS/Bond

Eudyna

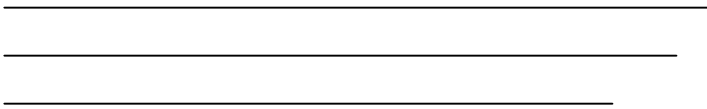

EMM5078X

C-Band Power Amplifier MMIC

For further information please contact :

Eudyna Devices USA Inc.
2355 Zanker Rd.
San Jose, CA 95131-1138, U.S.A.
TEL: +1 408 232-9500
FAX: +1 408 428-9111

Eudyna Devices Europe Ltd.
Network House
Norreys Drive
Maidenhead, Berkshire SL6 4FJ
United Kingdom
TEL: +44 (0) 1628 504800
FAX: +44 (0) 1628 504888

Eudyna Devices International Srl
Via Teglio 8/2 - 20158
Milano, Italy
TEL: +39-02-3705 2921
FAX: +39-02-3705 2920

Eudyna Devices Asia Pte. Ltd.
Hong Kong Branch
Suite 1906B, Tower 6, China Hong Kong City
33 Canton Road, Tsimshatsui, Kowloon
Hong Kong
TEL: +852-2377-0227
FAX: +852-2377-3921

Eudyna Devices Inc.
1000 Kamisukiahara, showa-cho
Nakakomagun, Yamanashi
409-3883, Japan
(Kokubo Industrial Park)
TEL +81-55-275-4411
FAX +81-55-275-9461

Sales Division
1, Kanai-cho, Sakae-ku
Yokohama, 244-0845, Japan
TEL +81-45-853-8156
FAX +81-45-853-8170

CAUTION

Eudyna Devices Inc. products contain **gallium arsenide (GaAs)** which can be hazardous to the human body and the environment. For safety, observe the following procedures:

- Do not put these products into the mouth.
- Do not alter the form of this product into a gas, powder, or liquid through burning, crushing, or chemical processing as these by-products are dangerous to the human body if inhaled, ingested, or swallowed.
- Observe government laws and company regulations when discarding this product. This product must be discarded in accordance with methods specified by applicable hazardous waste procedures.

Eudyna Devices Inc. reserves the right to change products and specifications without notice. The information does not convey any license under rights of Eudyna Devices Inc. or others.

© 2007 Eudyna Devices Inc.

Eudyna
