



FMM5804YD

K-Band Power Amplifier MMIC

FEATURES

- High Output Power; P_{1dB} = 24.5 dBm (Typ.)
- High Linear Gain; G_L = 17 dB(Typ.)
- Frequency Band ; 17.5 – 26.5 GHz
- SMT Laminate Package (YD Package)
- Impedance Matched Z_{in}/Z_{out} = 50Ω

DESCRIPTION

The FMM5804YD is a power amplifier MMIC that contains a four stage amplifier, internally matched, for standard communications band in 17.5 to 26.5GHz frequency range. This product is well suited for P-to-P, Ka-band V-SAT applications.

SEDI's stringent Quality Assurance Program assures the highest reliability and consistent performance.

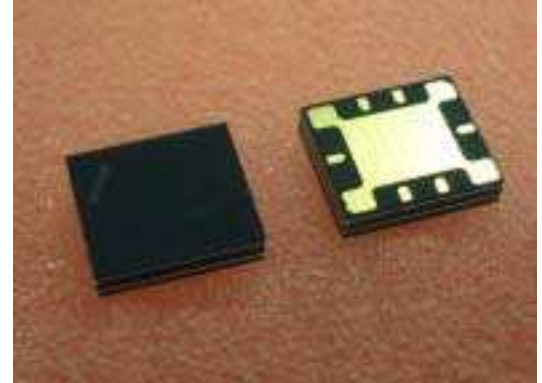

ABSOLUTE MAXIMUM RATING

Item	Symbol	Condition	Unit
Drain-Source Voltage	V _{DD}	10	V
Gate-Source Voltage	V _{GG}	-3	V
Input Power	P _{in}	16	dBm
Storage Temperature	T _{stg}	-55 to +125	°C

RECOMMENDED OPERATING CONDITIONS

Item	Symbol	Recommend	Unit
Dorain-Source Voltage	V _{DD}	<= 6	V
Input Power	P _{in}	<= +13	dBm
Operating Case Temperature	T _c	-40 to +85	°C

ELECTRICAL CHARACTERISTICS (Ambient Temperature Ta=25°C)

Item	Symbol	Test Conditions	Limits			Unit
			Min.	Typ.	Max.	
Frequency Range	f	V _{DD} =6V typ. I _{DD(DC)} =250mA typ. Z _S =Z _L =50ohm	17.5		26.5	GHz
Output Power at 1dB G.C.P.	P _{1dB}		22.5	24.5	-	dBm
Power Gain at 1dB G.C.P.	G _{1dB}		13	16	-	dB
Power-added Efficiency at 1dB G.C.P.	η _{add}		-	10	-	%
Drain Current at 1dB G.C.P.	I _{DDRF}		-	350	430	mA
Input Return Loss (at Pin=-20dBm)	RL _{in}		-	-15	-	dB
Output Return Loss (at Pin=-20dBm)	RL _{out}		-	-8	-	dB

G.C.P. : Gain Compression Point

ESD	Class 0	~ 250V
-----	---------	--------

Note : Based on JEDEC JESD22-A114-C

Case Style	YD
RoHS Compliance	Yes

ORDERING INFORMATION

Part Number	Order Unit	Packing
FMM5804YD	No Limitatio	64 pcs./Tray × 4 Tray = 256 pcs./Packing





FMM5804YD

K-Band Power Amplifier MMIC

Output Power vs. Frequency
@ $V_{DD}=6V$, $I_{DD(DC)}=250mA$

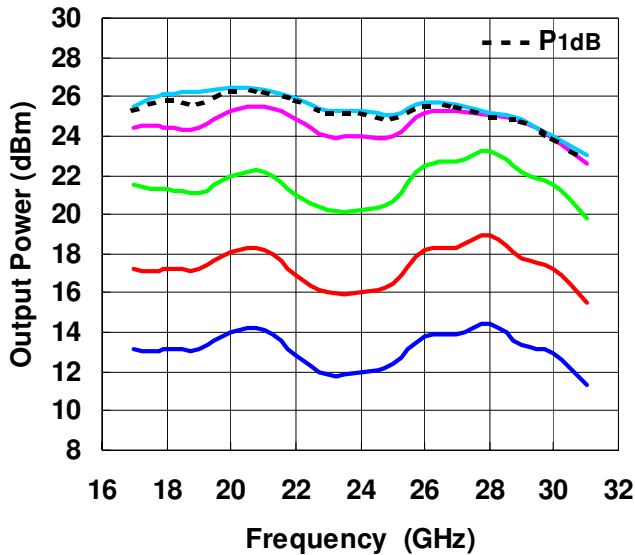

— Pin=-4dBm — 0dBm — 4dBm
— 8dBm — 12dBm

Power Added Efficiency vs. Frequency
@ $V_{DD}=6V$, $I_{DD(DC)}=250mA$

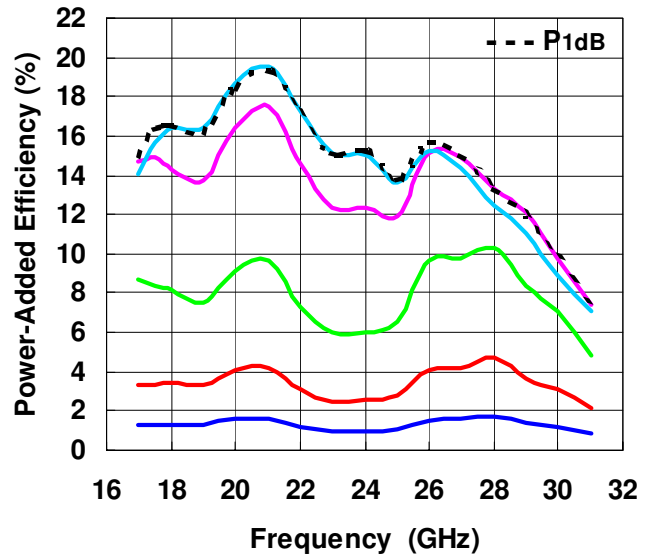

— Pin=-4dBm — 0dBm — 4dBm
— 8dBm — 12dBm

Output Power, Drain Current vs. Input Power
@ $V_{DD}=6V$, $I_{DD(DC)}=250mA$

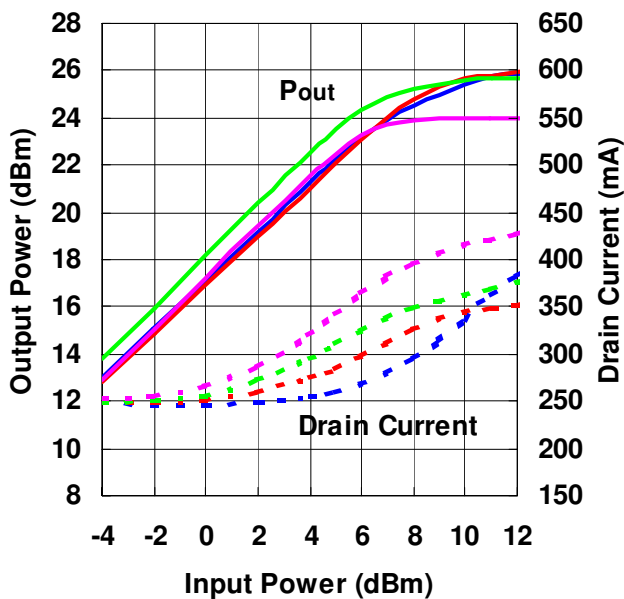

— 17.5GHz — 22GHz — 26GHz — 30GHz

IMD Performance vs. Total Output Power
@ $V_{DD}=6V$, $I_{DD(DC)}=250mA$
 $\Delta f=+10MHz$, 2-Tone test

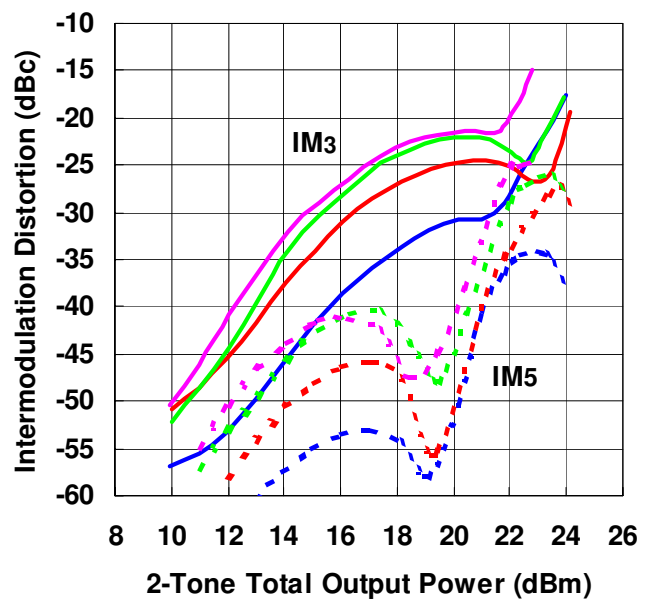

— 17.5GHz — 22GHz — 26GHz — 30GHz

Output Power, Drain Current vs. Input Power by Drain Current
@ freq.=17.5GHz, VDD=6V

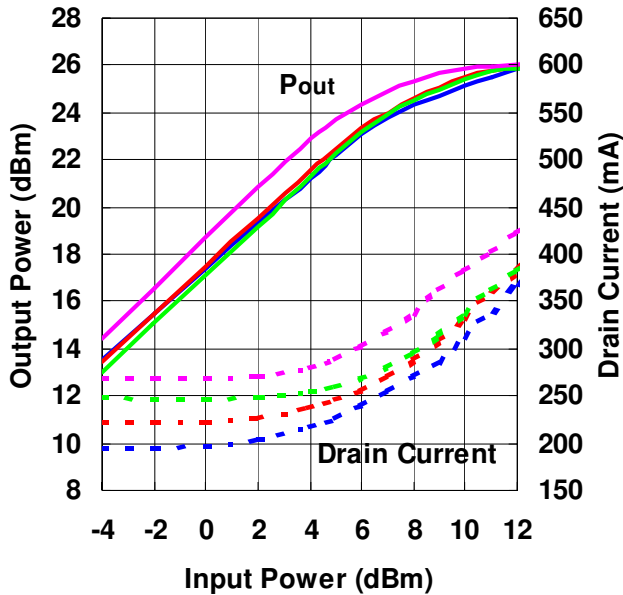

— 200mA — 225mA — 250mA — 275mA

Output Power, Drain Current vs. Input Power by Drain Current
@ freq.=22GHz, VDD=6V

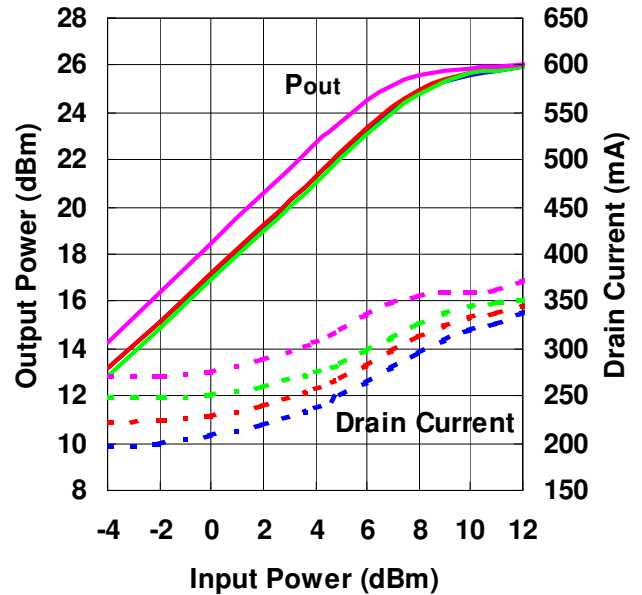

— 200mA — 225mA — 250mA — 275mA

Output Power, Drain Current vs. Input Power by Drain Current
@ freq.=26GHz, VDD=6V

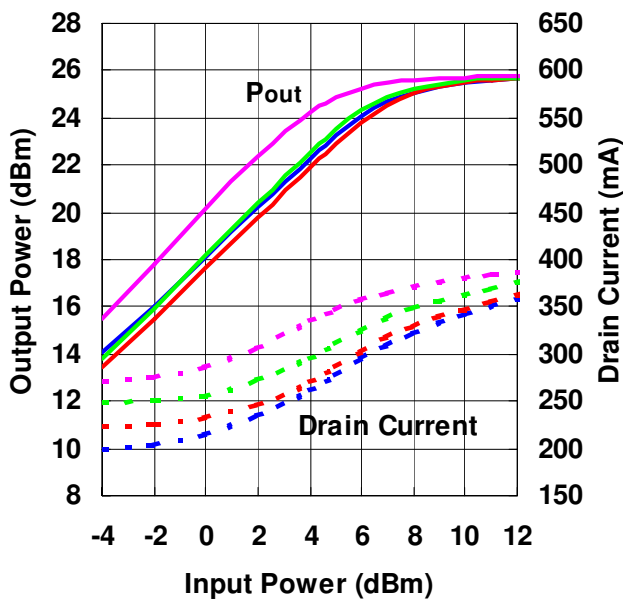

— 200mA — 225mA — 250mA — 275mA

Output Power, Drain Current vs. Input Power by Drain Current
@ freq.=30GHz, VDD=6V

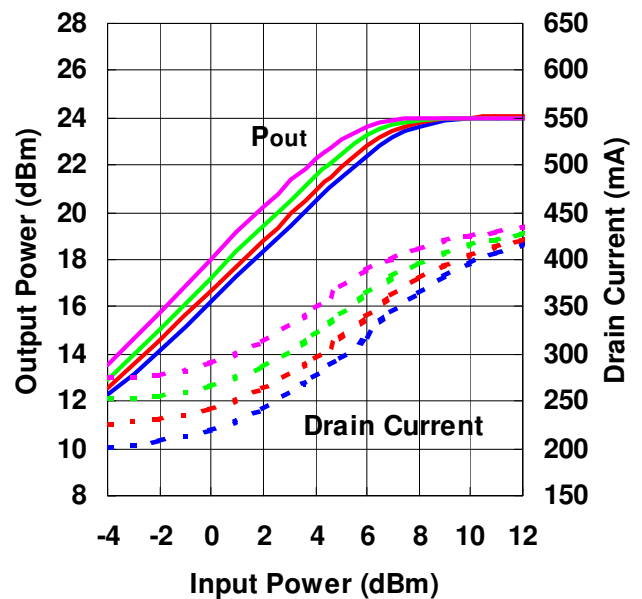

— 200mA — 225mA — 250mA — 275mA

Output Power, Drain Current vs. Input Power by Drain Voltage
@ freq.=17.5GHz, I_{DD}(DC)=250mA

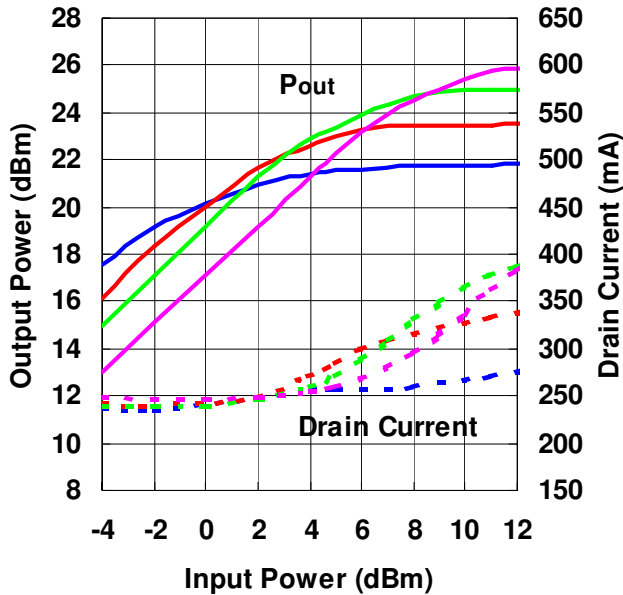

— 3V — 4V — 5V — 6V

Output Power, Drain Current vs. Input Power by Drain Voltage
@ freq.=22GHz, I_{DD}(DC)=250mA

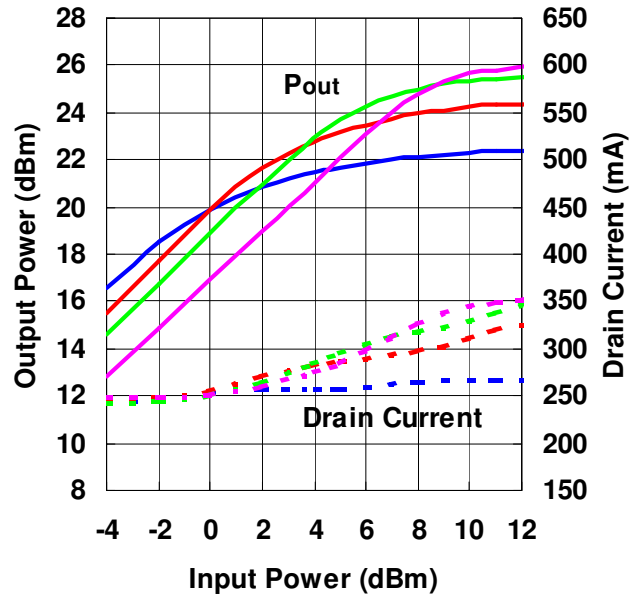

— 3V — 4V — 5V — 6V

Output Power, Drain Current vs. Input Power by Drain Voltage
@ freq.=26GHz, I_{DD}(DC)=250mA

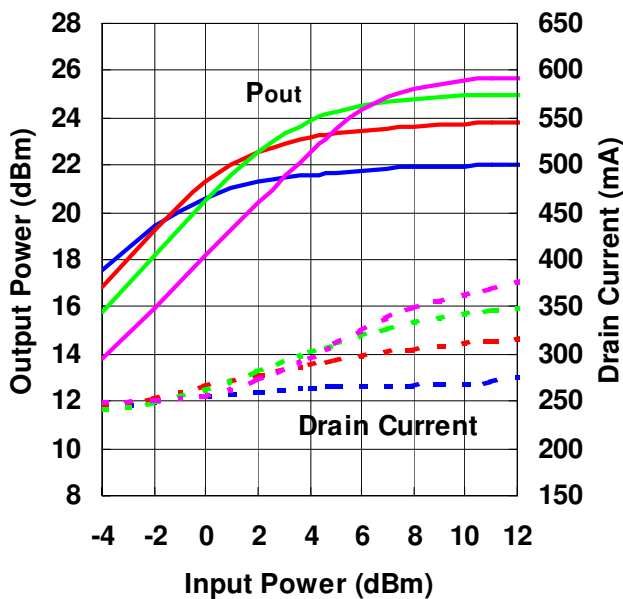

— 3V — 4V — 5V — 6V

Output Power, Drain Current vs. Input Power by Drain Voltage
@ freq.=30GHz, I_{DD}(DC)=250mA

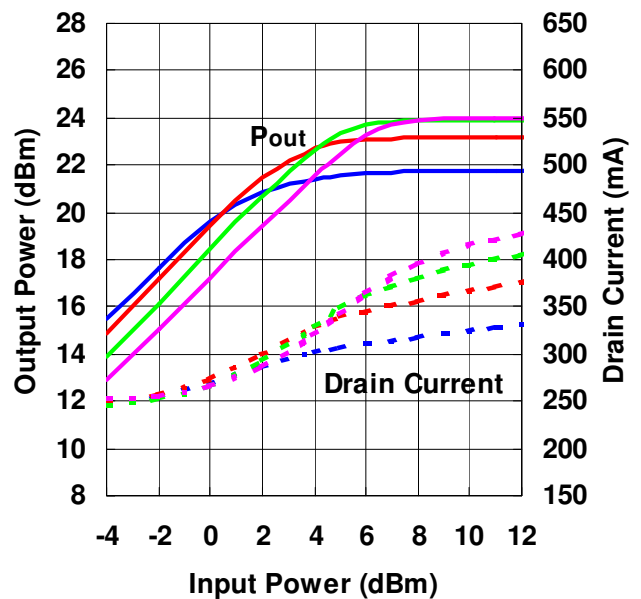

— 3V — 4V — 5V — 6V



FMM5804YD

K-Band Power Amplifier MMIC

P1dB, G1dB vs. Drain Current
@ VDD=6V

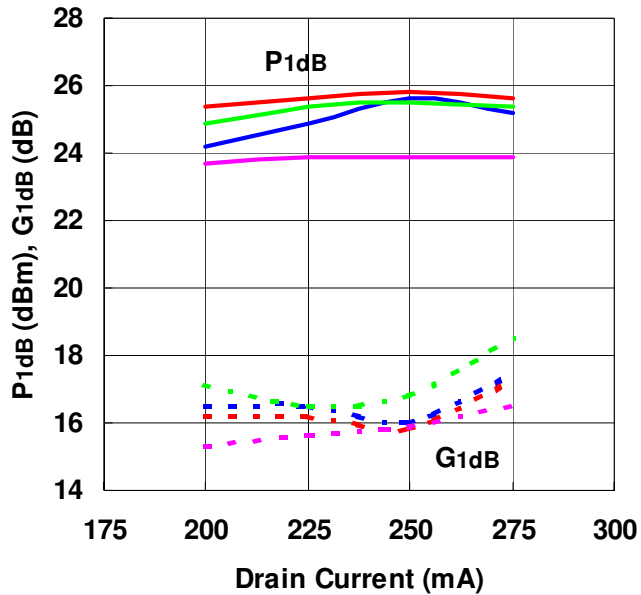

— 17.5GHz — 22GHz — 26GHz — 30GHz

P1dB, G1dB vs. Drain Voltage
@ I_{DD(DC)}=250mA

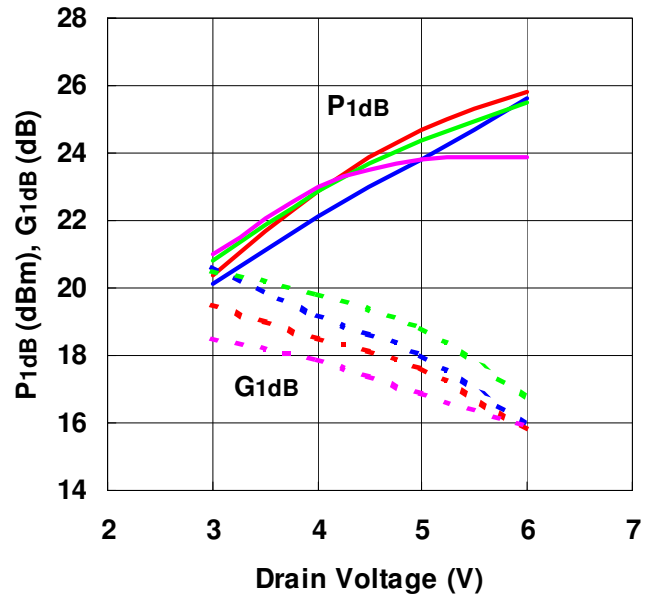

— 17.5GHz — 22GHz — 26GHz — 30GHz

IMD Performance vs. Total Output Power by Drain Current
 @ freq.=17.5GHz, VDD=6V
 Δf=+10MHz, 2-tone test

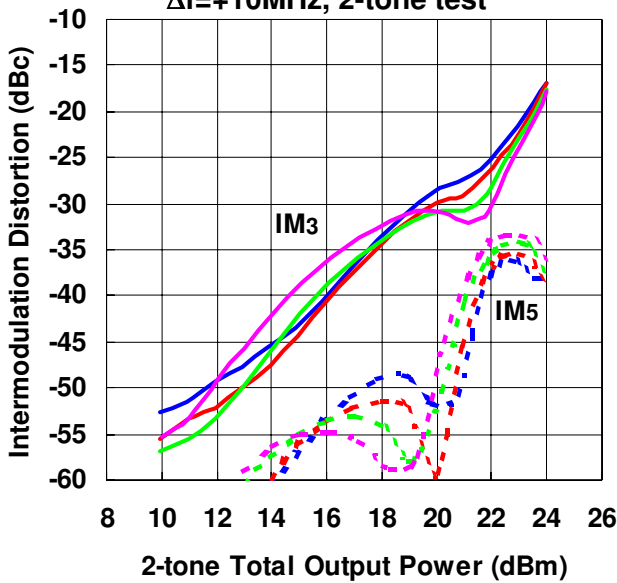

— 200mA — 225mA — 250mA — 275mA

IMD Performance vs. Total Output Power by Drain Current
 @ freq.=22GHz, VDD=6V
 Δf=+10MHz, 2-tone test

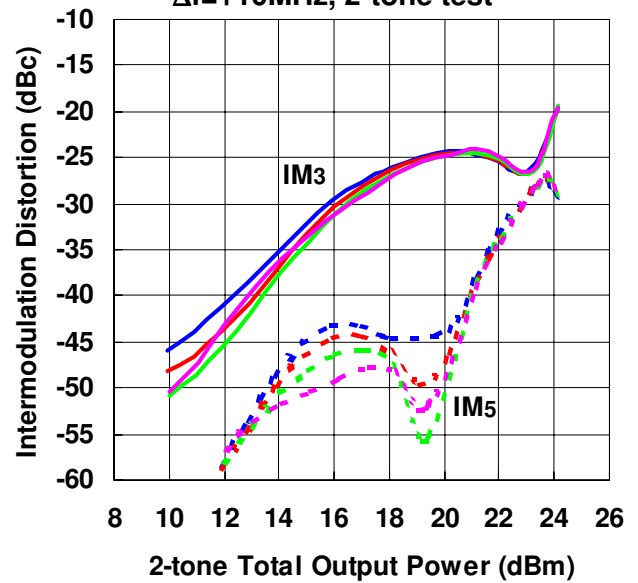

— 200mA — 225mA — 250mA — 275mA

IMD Performance vs. Total Output Power by Drain Current
 @ freq.=26GHz, VDD=6V
 Δf=+10MHz, 2-tone test

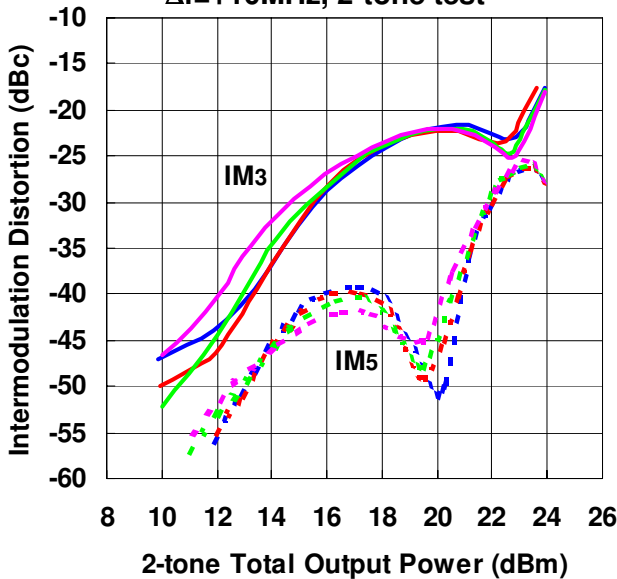

— 200mA — 225mA — 250mA — 275mA

IMD Performance vs. Total Output Power by Drain Current
 @ freq.=30GHz, VDD=6V
 Δf=+10MHz, 2-tone test

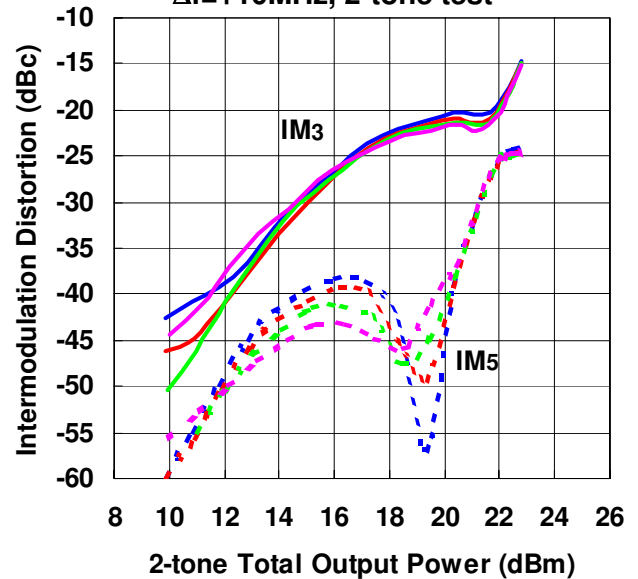

— 200mA — 225mA — 250mA — 275mA

IMD Performance vs. Total Output Power by Drain Voltage

@ freq.=17.5GHz, I_{DD}(DC)=250mA
Δf=+10MHz, 2-tone test

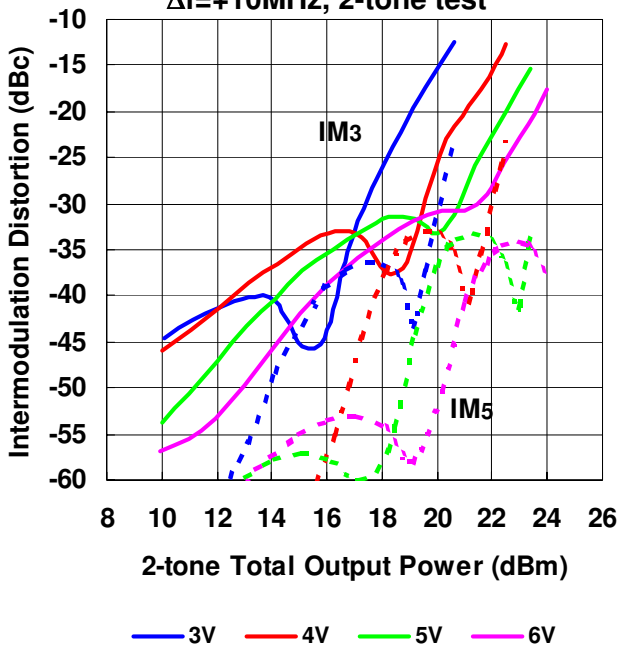

IMD Performance vs. Total Output Power by Drain Voltage

@ freq.=22GHz, I_{DD}(DC)=250mA
Δf=+10MHz, 2-tone test

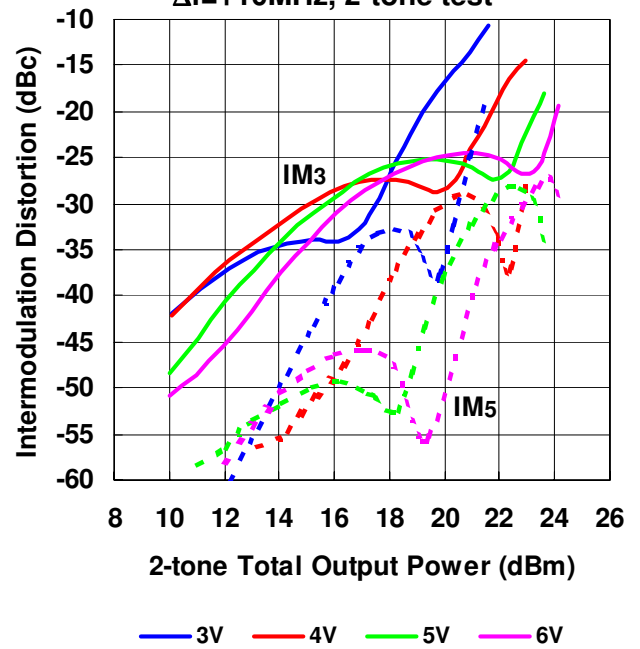

IMD Performance vs. Total Output Power by Drain Voltage

@ freq.=26GHz, I_{DD}(DC)=250mA
Δf=+10MHz, 2-tone test

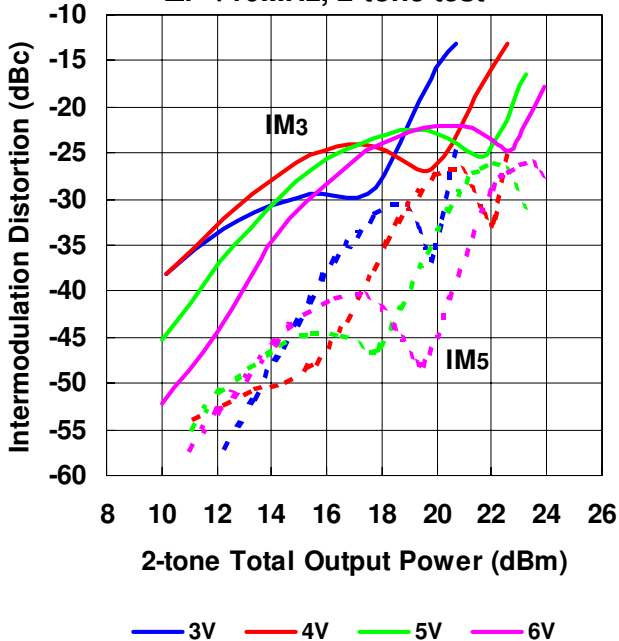

IMD Performance vs. Total Output Power by Drain Voltage

@ freq.=30GHz, I_{DD}(DC)=250mA
Δf=+10MHz, 2-tone test

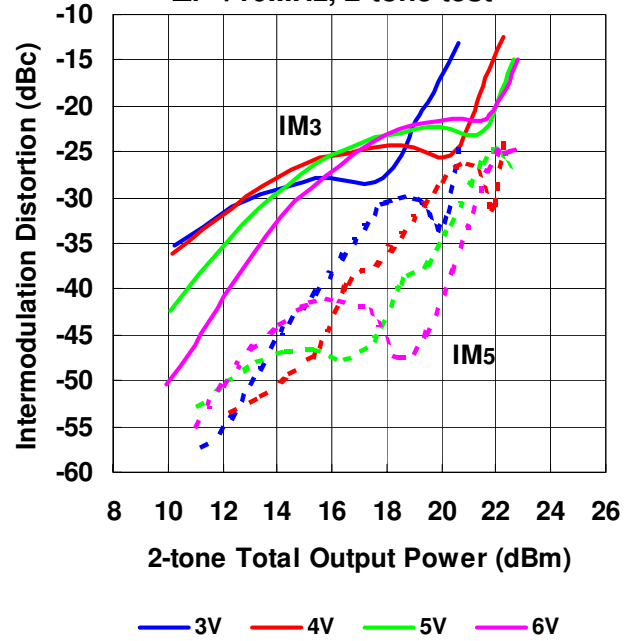



FMM5804YD

K-Band Power Amplifier MMIC

Small Signal Gain vs. Frequency
@ VDD=6V, IDD(DC)=250mA

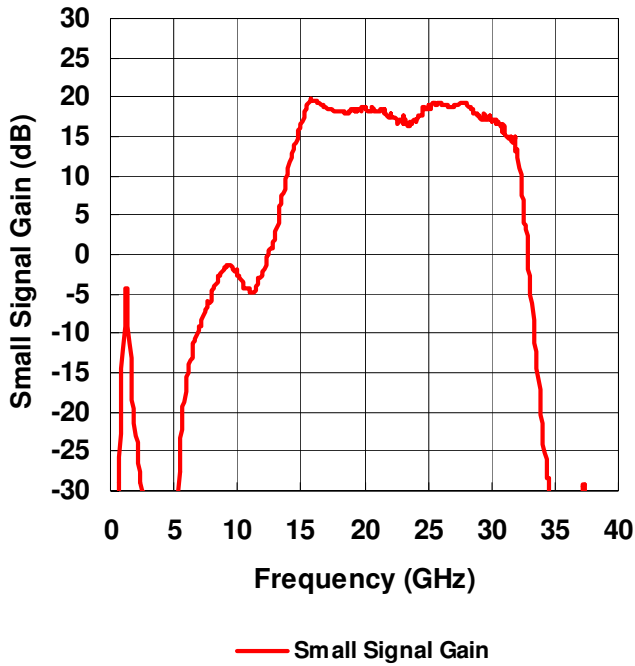

Return Loss vs. Frequency
@ VDD=6V, IDD(DC)=250mA

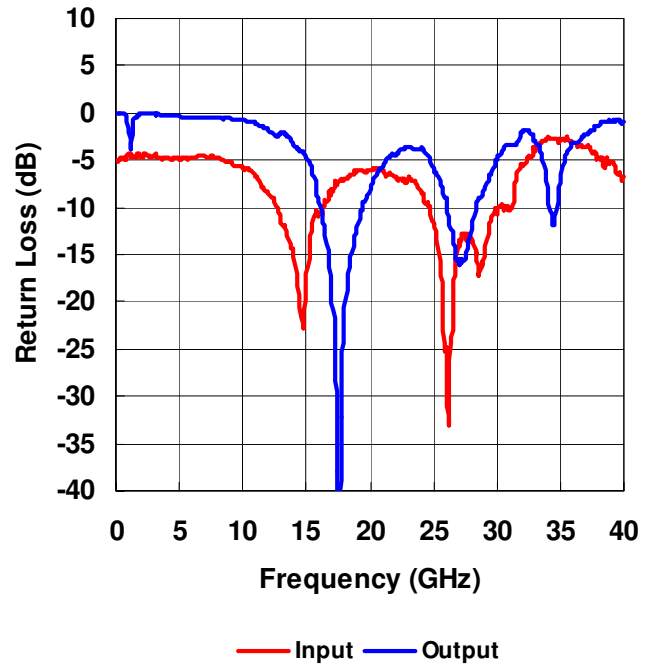



FMM5804YD

K-Band Power Amplifier MMIC

■ S-Parameters

@ VDD=6V, IDD(DC)=250mA

FREQ. [MHz]	S11		S21		S12		S22	
	mag.	ang.	mag.	ang.	mag.	ang.	mag.	ang.
1000	0.607	141.1	0.258	5.5	0.001	-120.2	0.835	-87.5
2000	0.583	100.0	0.070	-4.1	0.000	129.0	0.994	-130.4
3000	0.591	54.5	0.028	-62.0	0.001	-24.5	0.999	172.2
4000	0.577	10.3	0.022	-72.4	0.004	-23.9	0.974	121.5
5000	0.574	-30.7	0.016	-78.4	0.004	-51.4	0.959	71.8
6000	0.582	-70.4	0.154	-94.9	0.005	-72.3	0.947	23.2
7000	0.590	-105.6	0.347	170.6	0.005	-87.7	0.944	-24.5
8000	0.575	-138.3	0.554	84.9	0.006	-94.3	0.947	-68.5
9000	0.552	-169.3	0.820	-2.6	0.005	-107.6	0.938	-109.2
10000	0.506	164.9	0.761	-87.0	0.005	-65.6	0.917	-145.6
11000	0.460	137.2	0.601	-137.9	0.007	-88.3	0.879	-179.5
12000	0.374	109.7	0.771	-169.9	0.007	-103.3	0.809	148.8
13000	0.274	85.5	1.366	142.2	0.009	-95.3	0.790	119.8
14000	0.172	73.4	3.505	73.6	0.007	-99.8	0.681	82.7
15000	0.129	137.6	6.838	-16.2	0.010	-113.4	0.587	46.5
16000	0.290	98.6	9.513	-125.7	0.006	-67.6	0.340	0.8
17000	0.390	68.6	8.599	143.0	0.009	-118.1	0.105	-42.2
18000	0.449	39.5	8.189	63.0	0.006	-102.4	0.084	103.9
19000	0.496	8.2	8.098	-14.0	0.006	-100.4	0.249	66.2
20000	0.503	-24.1	8.316	-93.7	0.007	-99.9	0.397	29.7
21000	0.483	-54.8	8.051	-172.5	0.008	-100.8	0.533	-9.8
22000	0.462	-85.4	7.427	108.2	0.008	-113.5	0.607	-50.5
23000	0.464	-113.8	6.774	32.2	0.009	-149.0	0.662	-89.5
24000	0.378	-145.3	7.104	-36.3	0.006	153.5	0.646	-128.7
25000	0.253	176.0	8.354	-118.1	0.010	46.2	0.506	-179.5
26000	0.057	138.3	9.016	153.5	0.016	7.6	0.345	127.0
27000	0.212	-137.3	8.667	65.2	0.023	-30.1	0.156	82.8
28000	0.209	142.8	9.179	-29.5	0.024	-62.7	0.241	19.3
29000	0.174	62.2	7.605	-126.1	0.018	-65.0	0.393	-42.8
30000	0.287	-24.6	7.114	125.1	0.026	-86.9	0.564	-80.9
31000	0.307	-65.9	6.564	9.4	0.021	-130.5	0.673	-121.1
32000	0.532	-91.7	4.711	-141.2	0.003	-117.6	0.792	-148.9
33000	0.630	-115.8	0.696	59.2	0.018	-50.9	0.712	163.0
34000	0.739	-147.1	0.085	-59.4	0.021	-103.4	0.402	91.2
35000	0.732	-171.0	0.015	-153.7	0.018	-158.0	0.424	-85.2
36000	0.700	170.6	0.019	100.1	0.014	90.6	0.694	-149.9
37000	0.657	148.5	0.030	0.6	0.015	-1.4	0.764	-177.9
38000	0.581	132.1	0.022	-53.3	0.016	-38.7	0.858	158.4
39000	0.545	118.6	0.005	-38.3	0.013	-56.7	0.909	135.9
40000	0.464	97.9	0.013	-64.6	0.010	-63.0	0.887	114.4

**ΔTch vs. Drain Voltage
 (Reference)
 IDD=250mA**

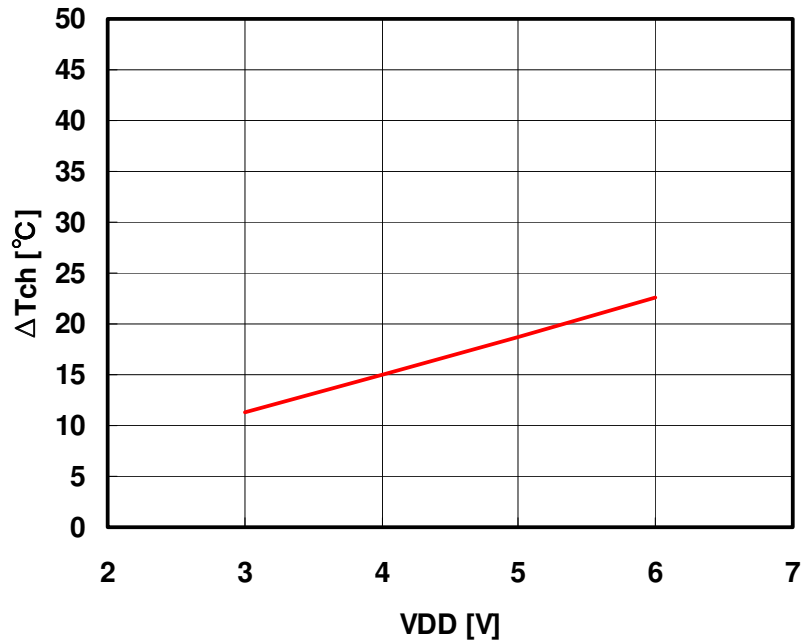

Note : ΔTch :Temperature Rise from Backside of the Package to Channel.

MTTF vs. Tch

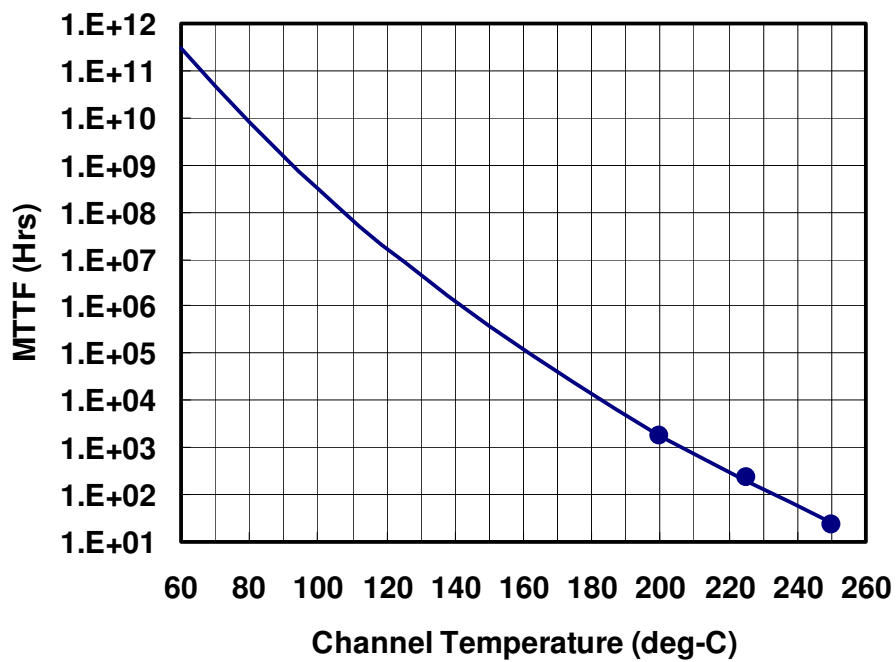

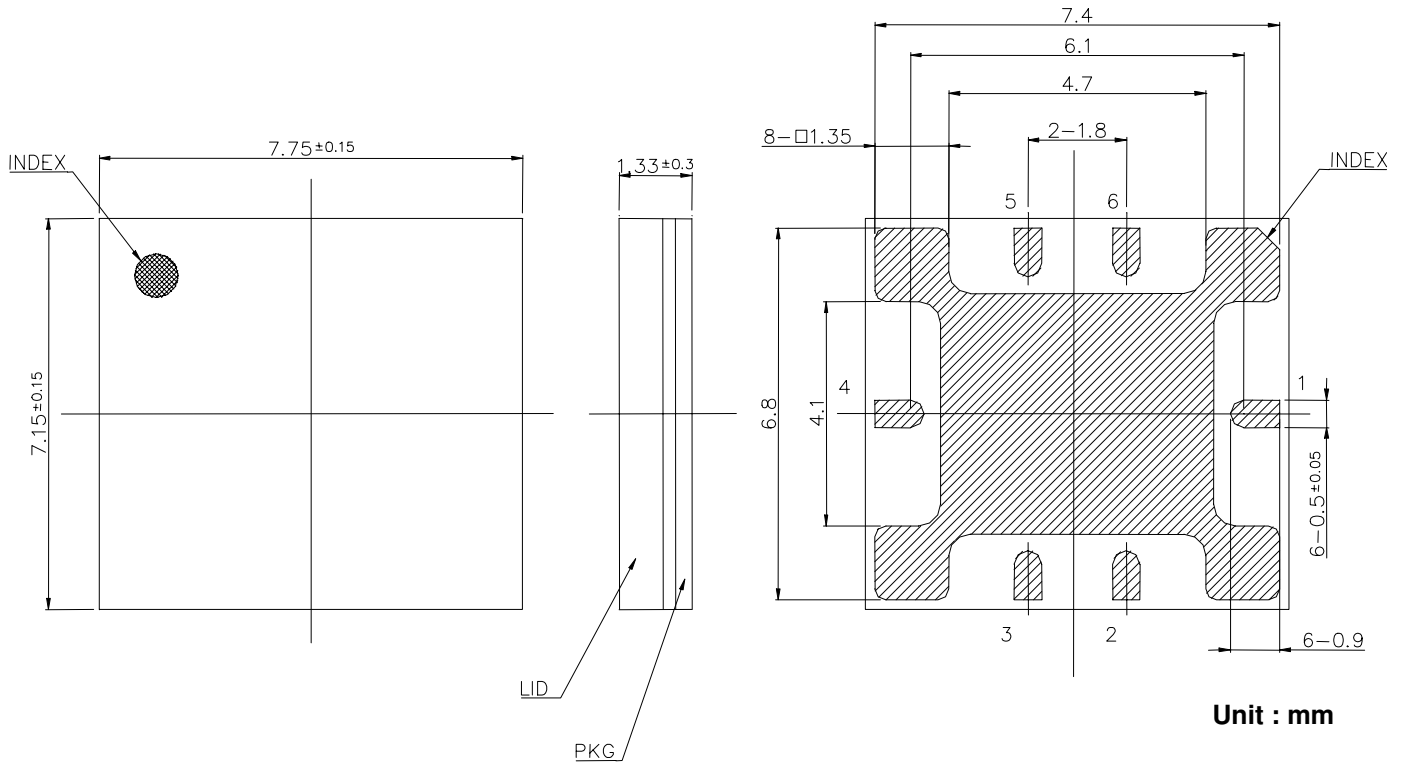

Pin Assignment

- 1 : RF-in
- 2 : VDD1
- 3 : VDD2
- 4 : RF-out
- 5 : VGG
- 6 : N.C.

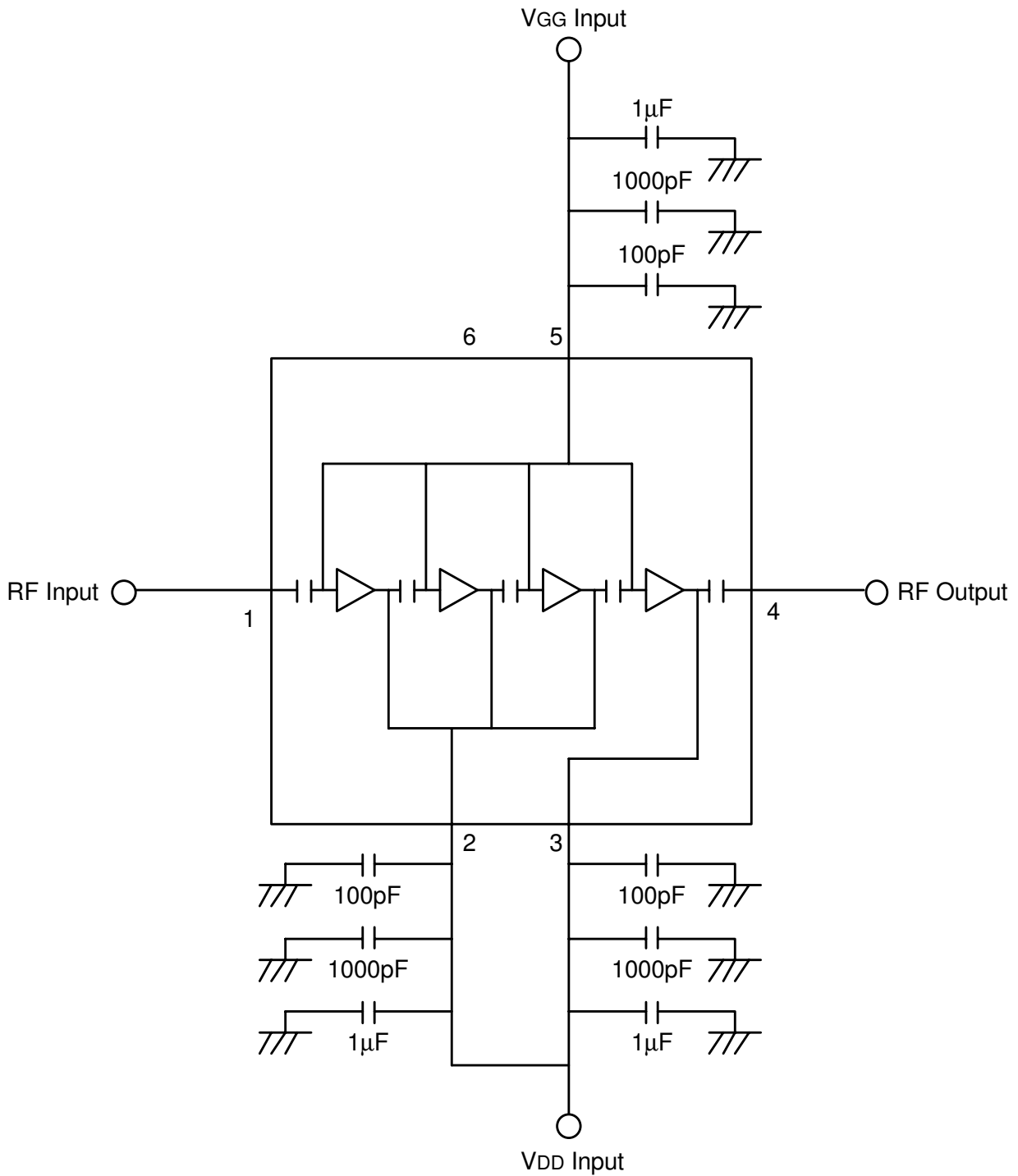

Note) : The capacitors are recommended on the bias supply line, close to the package, in order to prevent video oscillations which could damage the module.

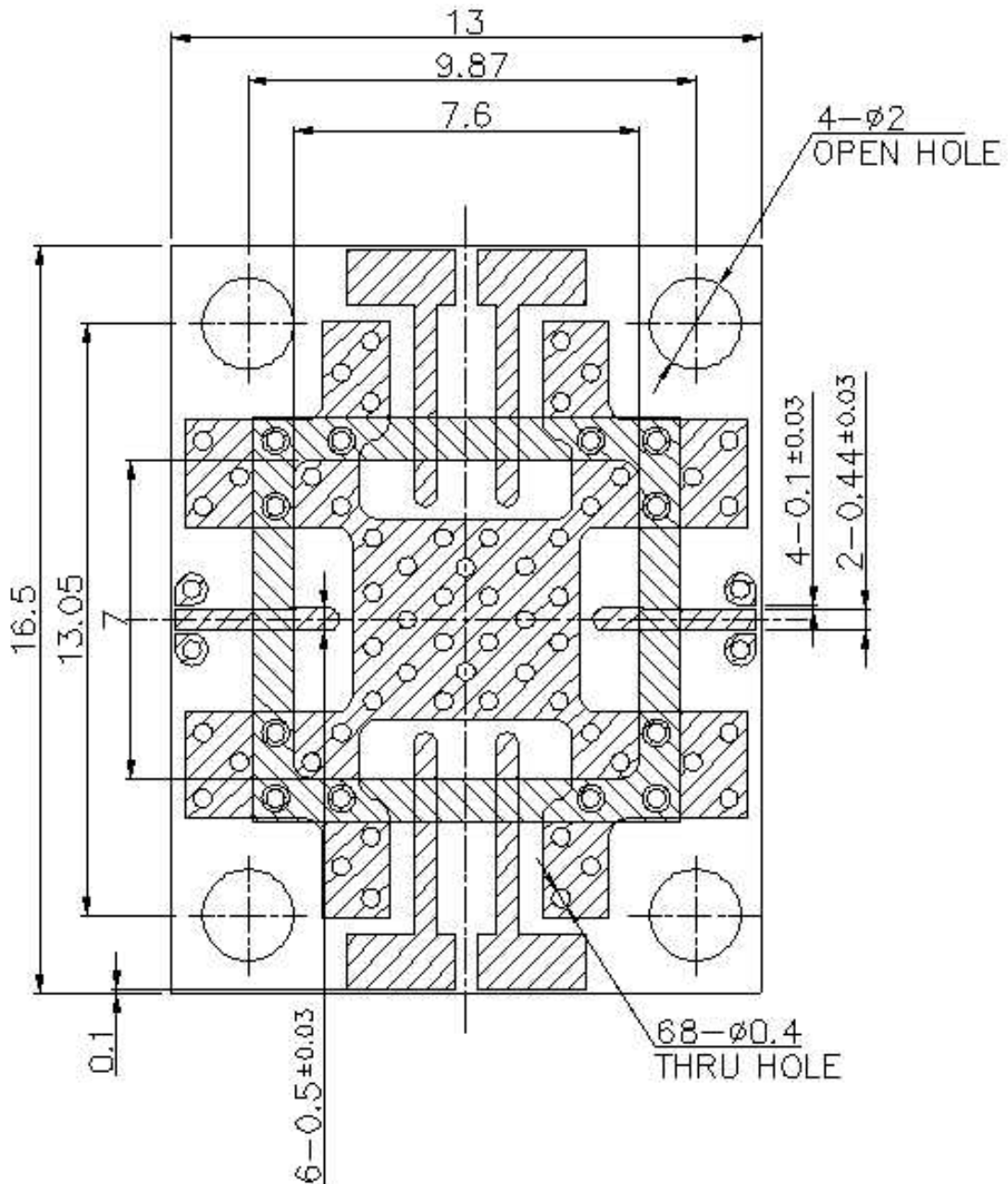

Unit : mm

Notes :

- 1.LAMINATE : Rogers Corporation RO4003, Thickness $t=0.2\text{mm}$, Cu Foil $18\ \mu\text{m}$
2. : Finish to copper foil ; Ni $0.1\ \mu\text{m}$ min./Au $0.1 \pm 0.08\ \mu\text{m}$ (Both side)
3. : Resist

■ 4-inch Tray Packing (Part No. : FMM5804YD)

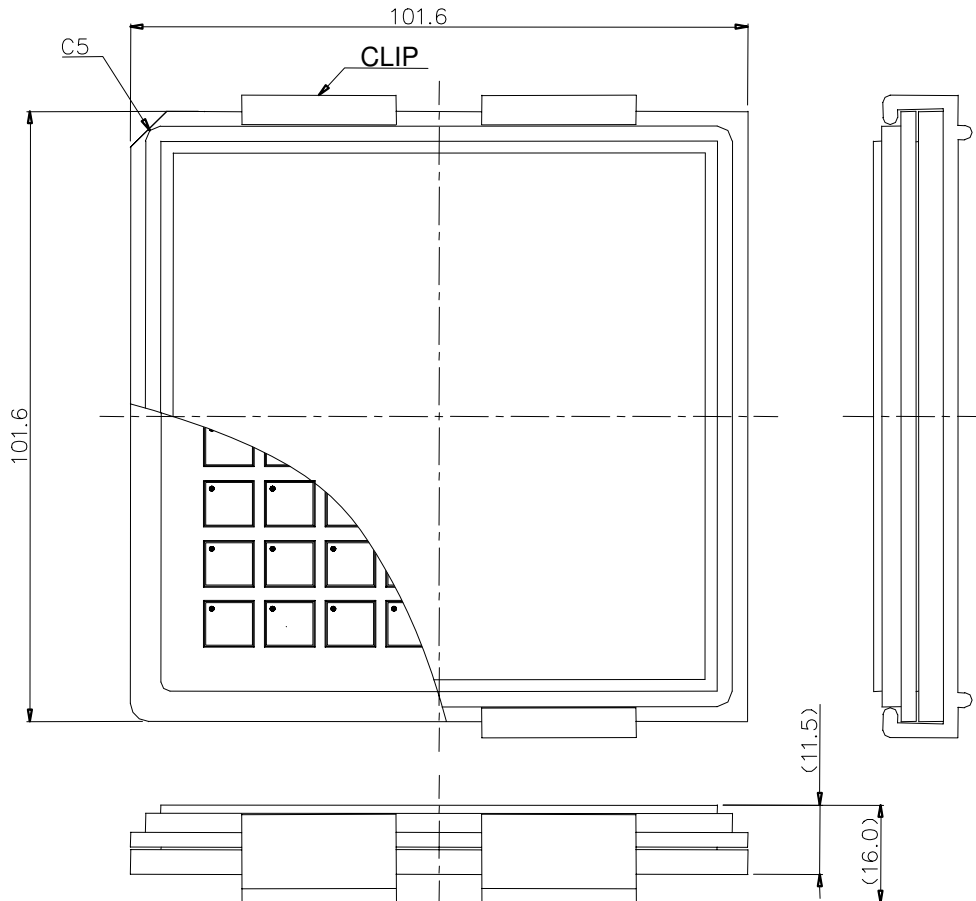

(unit in mm)

- (1) Maximum Quantity : 64pcs./Tray
- (2) Tray Material : Conductive PPE
- (3) Clip Material : Conductive PP

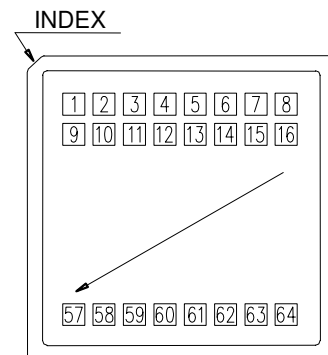

■ Mounting Method of SMD(Surface Mount Devices) for Lead-free Solder

Mounting Condition

- (1) For soldering, Lead-free solder (Sn-3.0Ag-0.5Cu)*¹ or equivalent shall be used.
 (*1: The figure displays with weight %. A predominantly tin-rich alloy with 3.0% silver and 0.5% copper.)
- (2) A rosin type flux with a chlorine content of 0.2% or less shall be used. The rosin flux with low halogen content is recommended.
- (3) When soldering, use one of the following time / temperature methods for acceptable solder joints. Make sure the devices have been properly prepared with flux prior soldering.

* Reflow soldering method (Infrared reflow / Heat circulation reflow / Hot plate reflow):

Limit solder to 3 reflow cycles because resin is used in the modules manufacturing process. Excessive reflow cycles will effect the resin resulting in a potential failure or latent defect. The recommended reflow temperature profile is shown below. The temperature of the reflow profile must be measured at the device lead.

Reflow temperature profile and condition:

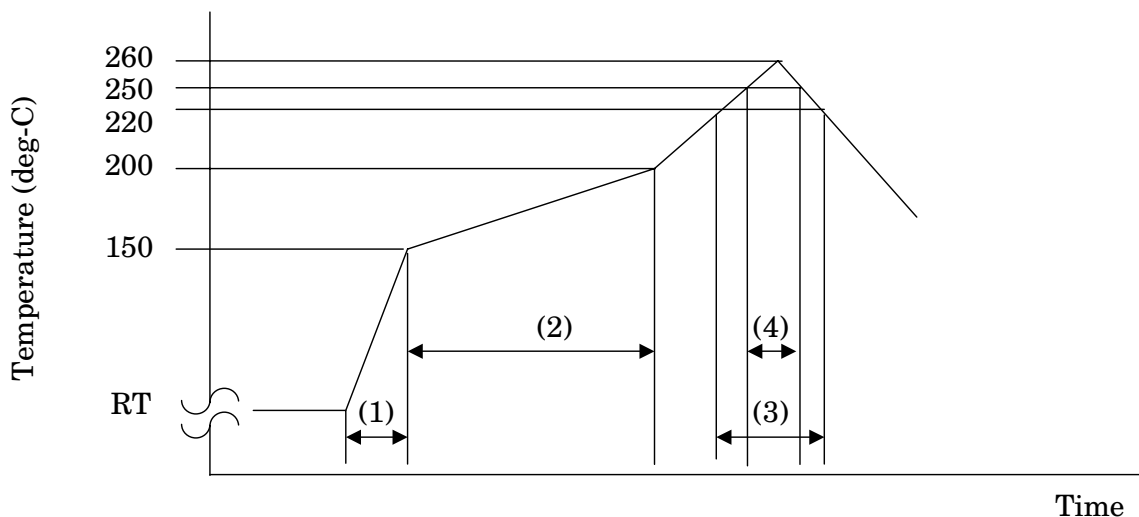

- | | |
|-----------------------|----------------------------------------------------|
| (1) Temperature rise: | 3deg-C /seconds. |
| (2) Preheating: | 150 – 200deg-C, 60 – 180 seconds. |
| (3) Main heating: | 220deg-C, 60 seconds max... |
| (4) Main heating: | 260deg-C max. more than 250deg-C, 10 seconds max.. |
- * Measurement point: Device lead.

- (4) The above-recommended conditions were confirmed using the manufacture's equipment and materials. However, when soldering these products, the soldering condition should be verified by customer using their equipment and materials.

■ **Moisture Sensitivity levels(MSL)**

* Floor life

Table 1. Moisture classification level and floor life

Level	Floor life(*1)	
	Time	Condition
1	Unlimited	=<30 degC / 85%RH
2	1year	=<30 degC / 60%RH
2a	4weeks	=<30 degC / 60%RH
3	168hours	=<30 degC / 60%RH
4	72hours	=<30 degC / 60%RH
5	48hours	=<30 degC / 60%RH
5a	24hours	=<30 degC / 60%RH
6	<24hours (*2)	=<30 degC / 60%RH

*1 Floor life means the maximum time allowed between open the bag and mounting reflow at the customer's factory.

*2 Device classified as level 6 must be dried by baking, then reflowed within the time limit specified each device.

Table 1 is an extract from IPC/JEDEC J-STD-020B.

* MSL of device

Package Type	MSL
YC, YD, YE, YF	3

If storage time, temperature or humidity condition is exceeded for floor life, please bake the device.
Baking condition : 125degC, 24hours

Humidity Lifetime for FMM5804YD

The following graph shows the lifetime of moisture resistance for the **FMM5804YD**. Each line in the graph indicates the lifetime that is the estimated failure rate of **0.1% at 10 years** (Confidence Level = 90 %) and calculated from the results of pressure cooker (autoclave) bias test. The horizontal-axis shows typical ambient temperature. The vertical-axis shows relative humidity. The left side of the area delimited in each line indicates more than 10 years of lifetime.

Field environmental conditions for operation

In the case that **FMM5804YD** is mounted in a non-hermetic package, please refer to the following recommendations.

- Note 1. The graph lines are drawn using the operating conditions as shown in the box below. SEDI recommends our customers use **FMM5804YD** within the left side area separated by each line in the graph below.
- Note 2. Please cut off the drain current by drain bias, not by gate bias. The humidity lifetime becomes shorter in case of gate cut off operation.
- Note 3. Please use ES/FMM5804YD under environmental conditions of no dew condensation.

Field Environmental Conditions for a 10 years Lifetime

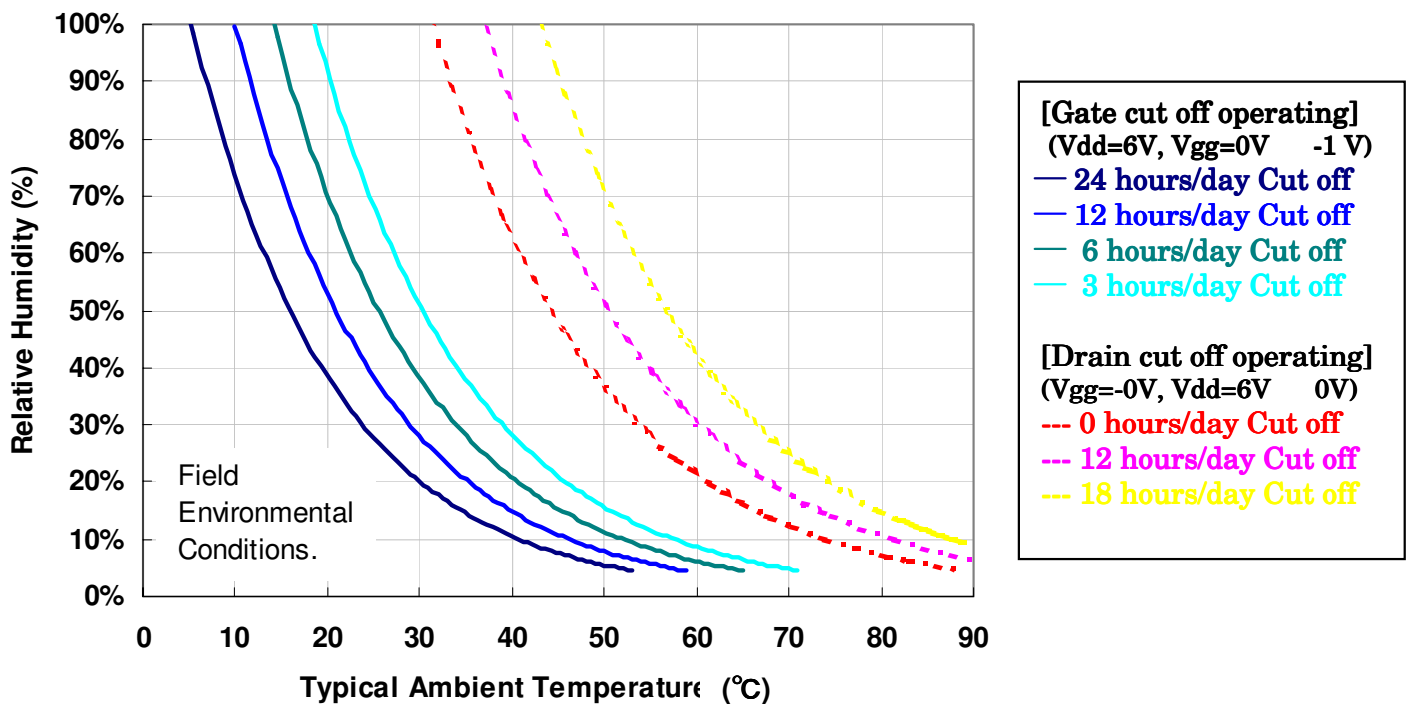



FMM5804YD

K-Band Power Amplifier MMIC

For further information please contact :

**Sumitomo Electric Device Innovations,
U.S.A., Inc.**

2355 Zanker Rd.
San Jose, CA 95131-1138, U.S.A.
TEL: +1 408 232-9500
FAX: +1 408 428-9111

Sumitomo Electric Europe Ltd.

220 Centennial Park,
Elstree WD6 3SL United Kingdom
TEL: +44 (0)20 89538118
FAX: +44 (0)20 89538228

Sumitomo Electric Europe Ltd. (Italy Branch)

Piazza Don E. Mapelli, 60 - 20099
Sesto San Giovanni, Milano - Italy
TEL: +39-02-496386-01
FAX: +39-02-496386-25

Sumitomo Electric Asia, Ltd.

Room 2624-2637, 26/F.,
Sun Hung Kai Centre,
30 Harbour Road, Wanchai,
Hong Kong
TEL: +852-2576-0080
FAX: +852-2576-6412

Sumitomo Electric Device Innovations, Inc.

1000 Kamisukiahara, showa-cho
Nakakomagun, Yamanashi
409-3883, Japan
(Kokubo Industrial Park)
TEL +81-55-275-4411
FAX +81-55-275-9461

Sumitomo Electric Industries, Ltd.

Head Office (Tokyo)
3-9-1, Shibaura, Minato-ku, Tokyo 108-8539,
Japan
TEL +81-3-6722-3283
FAX +81-3-6722-3284

CAUTION

Sumitomo Electric Device Innovations, Inc. products contain **gallium arsenide (GaAs)** which can be hazardous to the human body and the environment. For safety, observe the following procedures:

- Do not put these products into the mouth.
- Do not alter the form of this product into a gas, powder, or liquid through burning, crushing, or chemical processing as these by-products are dangerous to the human body if inhaled, ingested, or swallowed.
- Observe government laws and company regulations when discarding this product. This product must be discarded in accordance with methods specified by applicable hazardous waste procedures.

Sumitomo Electric Device Innovations, Inc. reserves the right to change products and specifications without notice. The information does not convey any license under rights of Sumitomo Electric Device Innovations, Inc. or others.

© 2009 Sumitomo Electric Device Innovations, Inc.

